

---

new . york . independent . system . operator



nyiso  
Emergency Demand Response Program  
Manual

revised: ~~03 . 05 . 2002~~02 . 20 . 2003

## What's New for ~~2002~~2003?

---

Section	Topic
<del>3.8</del> .....	<del>Alternative Performance Measures for Small Customer Aggregations can be submitted for approval to the NYISO.</del>
<del>3.9</del> .....	<del>Curtailment Service Providers must participate in NYISO sponsored EDRP program evaluations.</del>
<del>5.2</del> .....	<del>On-site generators must supply evidence that they have applied for or received from the NYS Dept. of Environmental Conservation (DEC) one of the following permits (i) Title V, (ii) State Facility, or (iii) Registration.</del>
<del>5.3</del> .....	<del>Updated EDRP Notification Procedures to reflect the procedures put in place during the summer 2001.</del>
<del>6.1</del> .....	<del>Updated Metering Requirements</del>
<del>6.2</del> .....	<del>Alternative weather-sensitive Customer Base Line (CBL) options</del>
<del>6.7</del> .....	<del>Updated Settlement Payment timeline</del>
<del>Att. A, B</del> .....	<del>Updated registration forms to reflect the changes above.</del>
<del>Att. D</del> .....	<del>Added .csv event data reporting format description.</del>

---

Following the summer of 2002, a number of changes to the EDRP and ICAP SCR programs were approved by the NYISO Market Participants:

1. Extend the EDRP program through October 31, 2005. Consistent with past practice, the PRL working group will continue to monitor and evaluate the operation of the EDRP program and will propose changes should they be necessary. A report on program performance, including impact in both the day-ahead and real time markets and the effect of program changes on customer participation and satisfaction, will be prepared and presented to the Business Issues Committee annually in November for the duration of the program. Program operation and participant performance are subject to review by the NYISO's Market Monitoring Unit.
2. Separate operational calls of SCR from EDRP. SCR would be the first resources selected. If more than the total capability of SCR is projected to be needed, then the EDRP would be activated as well. However, the same MWs cannot participate in both programs. A customer with sufficient metering to distinguish between their SCR and EDRP resources could participate in both programs.
3. NYISO System Operations will decide how much and from where SCR/EDRP is called and may specify the need at a zonal level. The amount of SCR/EDRP that is called will reflect Operations' expectation of actual performance. Notification time and the obligation to perform remain unchanged from current SCR and EDRP requirements. Both programs will be called to respond to emergency situations (i.e. where forecasted reserves are short).

## **SCR**

4. Institute a minimum guarantee price approach whereby SCR resources will specify an energy curtailment payment up to the EDRP payment level (\$500/MWh). A guarantee price submitted to the ISO will remain in effect until changed by the participant. A participant would have the option to revise its guarantee price monthly by some deadline prior to the 1<sup>st</sup> day of each month.
5. SCRs are the first resources selected. If something less than all of the SCR resources are needed in the selected zones, then SCRs will be called according to a priority based on the minimum guarantee prices that will serve the need at the lowest price. Partial calls within a given price level will be done on a round-robin basis, in the unlikely event that this situation occurs.
6. SCR minimum guarantee prices would be eligible to participate in the LBMP price setting under the hybrid pricing rules. SCR would be paid the higher of the minimum guarantee or LBMP. The energy payments for measured performance will be calculated in a manner that is consistent with that of the EDRP program. A bid production cost guarantee will be paid to SCR participants based on their own minimum guarantee price, calculated over the 4-hour minimum period.

## **EDRP**

7. The EDRP program will continue to pay EDRP customers the higher of \$500/MWh or LBMP when called. Minimum payment guarantees will remain unchanged from the current EDRP program.
8. The NYISO will call all EDRP that is available in the zone(s) that are activated. No pro-rating or round-robin selection would be implemented at this time, although program participation will continue to be monitored by PRL and the ISO and will be revisited in the future if necessary.
9. \$500 EDRP price is eligible to participate in LBMP price setting under the hybrid pricing methods.

Organizations interested in registering for the ICAP Special Case Resources Program should review the rules and regulations found in the latest ICAP Manual [1] located on the NYISO website at [www.nyiso.com/markets/icapinfo.html](http://www.nyiso.com/markets/icapinfo.html). Questions regarding participation should be directed to John Charlton at 518-356-6047 ([jcharlton@nyiso.com](mailto:jcharlton@nyiso.com)).

Additional changes for 2003 can be found in the following sections of the manual:

<u>Section</u>	<u>Topic</u>
<u>2.0</u>	<u>Removed 25 MW cap on small customer aggregation program</u>
<u>5.2.1</u>	<u>Notes that program participants are responsible for ensuring compliance with the ultra-low sulfur fuel requirements and for the emissions testing requirements for model 1994 and older generators.</u>
<u>6.1.1</u>	<u>Clarifies that meter certification data is required only for non-revenue grade meters.</u>

- 6.2.1                      Notes that the CSP is responsible for CBL calculation.
  - 6.6.4                      Clarifies that the NYISO provides hourly payment information by customer to CSPs separate from the consolidated invoice.
-

## 1.0 Definitions and Acronyms

---

**Capability Period** - Six (6) month periods which are established as follows: (1) from May 1 through October 31 of each year (“Summer Capability Period”); and (2) from November 1 of each year through April 30 of the following year (“Winter Capability Period”).

**Curtailement Customer Aggregator (or Aggregator)** – An organization qualified as a CSP that enters into contracts with Demand Side Resources to either interrupt load or start up Local Generation under the EDRP.

**Curtailement Program End Use Customer (EUC)** – A retail end-user that qualified as a CSP and can either interrupt load or start up Local Generation under the EDRP.

**Curtailement Services Provider (CSP)** – A qualified provider that can produce real-time, verified reductions in NYCA Load of at least 100 kW, pursuant to the Emergency Demand Response Program (“EDRP”) and related ISO procedures. CSPs can be either an LSE, a Direct Customer, a Curtailement Customer Aggregator, or a Curtailement Program End Use Customer.

**Customer Base Load (CBL)** – Average hourly energy consumption as calculated in Section 6, used to determine the level of load curtailment provided.

**Day-Ahead Zonal LBMP** – The price (in \$/MWh) for combined energy, losses, and transmission congestion determined on an hourly basis in the day-ahead electricity market.

**Demand Side Resources** - Resources that result in the reduction of a Load in a responsive and measurable manner and within time limits established in the ISO Procedures.

**EDRP** – Emergency Demand Response Program, described in this manual.

**EDRP Loads** – Retail end-users that provide load reduction and have been registered through a CSP to participate in the Emergency Demand Response Program.

**Emergency Condition** - Any abnormal system condition as specified by the ISO that requires immediate automatic or manual action to prevent or limit loss of transmission facilities or Generators that could adversely affect the reliability of the electric system.

**Emergency Generation** - An electrical generator installed to handle emergency outages at a facility, for short periods of time.

**In-Day Peak Hour Forecast** – Forecasted morning and evening peak loads as determined by the NYISO Shift Supervisor or his assignee, used to evaluate total operating capacity.

**Installed Capacity (ICAP)** - A Generator or Load facility that complies with the requirements in the Reliability Rules and is capable of supplying and/or reducing the demand for energy in the New York Control Area for the purpose of ensuring that sufficient energy and capacity are available to meet reliability rules. The Installed Capacity requirements, established by the New York State Reliability Council, include a margin of reserve in accordance with the Reliability Rules.

**Interval Metering** – An approved metering device, which records electricity usage for each fifteen-minute period during a billing period.

**Load Bank** - An electric resistance coil or similar device that creates an electric load which is used for testing generators under load.

**Load Curtailment (or Reduction)** - A reduction in energy usage at a retail end user's facility that is the result of the retail end user either reducing the energy consumed or operating an on-site generator.

**Load Serving Entity (LSE)** – Any entity, including a municipal electric system and an electric cooperative, authorized or required by law, regulatory authorization or requirement, agreement, or contractual obligation to supply Energy, Capacity and/or Ancillary Services to retail end users located within the NYCA, including NYISO Direct Customers.

**Local Generator** - A generator operated by or on behalf of loads offering load reductions pursuant to the Emergency Demand Response Program. Such generators are not synchronized to a utility's local distribution system or, if synchronized to the local distribution system, support a load that is equal to or in excess of the generator's capacity; *i.e.* when operating, the local generator supplies energy only to the end user whose load it is being operated to serve and does not supply energy to the distribution system. On-site generators that are base-loaded do not qualify for the EDRP.

**Locational Based Marginal Price (LBMP)** - The price of energy bought or sold in the LBMP Markets at a specific location or zone.

**Meter Service Provider (MSP)** - An entity that provides meter services, consisting of the installation, maintenance, testing and removal of meters and related equipment.

**Meter Data Service Provider (MDSP)** – An entity providing meter data services, consisting of meter reading, meter data translation and customer association, validation, editing and estimation.

**New York Independent System Operator (NYISO)** - Not for profit organization created to supply New York's electric power needs and to facilitate the power market equitably.

**NYCA** –The Control Area that is under the control of the NYISO which includes transmission facilities listed in the ISO/TO Agreement Appendices A-1 and A-2, as amended from time-to-time, and Generation located outside the NYS Power System that is subject to protocols which allow the ISO and other Control Area operator(s) to treat some or all of that Generation as though it were part of the NYS Power System.

**NYISO Customer** – An entity which has complied with the requirements contained in the ISO Services Tariff, including having signed a Service Agreement, and is qualified to utilize the Market Services and the Control Area Services provided by the NYISO under the ISO Services Tariff; provided, however, that a party taking services under the Tariff pursuant to an unsigned Service Agreement filed with the Commission by the NYISO shall be deemed a Customer.

**NYISO Direct Customer** – An entity, which takes or provides service directly from or to the NYISO, and is responsible for bidding, scheduling, and billing functions for their facilities.

**NYISO Limited Customer** – An entity that joins the NYISO to participate in the EDRP; registration requirements are the same as for a NYISO Customer except that a Limited Customer:

- Is not required to satisfy the financial assurance obligations imposed on Customers,
- Their status as a Limited Customer expires at the end of the EDRP program, and
- Voting privileges are waived with respect to the governance process.

All NYISO Customers meeting the eligibility criteria set forth in Section 3 qualify as Limited Customers, and may participate in the EDRP subject to the registration procedures defined in Section 4.

**NYISO Services Tariff** – The document that sets forth the provisions applicable to the services provided by the ISO related to its administration of competitive markets for the sale and purchase of Energy and Capacity and for the payments to Suppliers who provide Ancillary Services to the ISO in the ISO Administered Markets and provision of Control Area Services, including services related to ensuring the reliable operation of the NYS Power System.

**NYS DEC** – New York State Department of Environmental Conservation

**Operating Reserve Shortage** – Failure to maintain the Minimum Operating Reserve Requirement as defined in Section 4.1.1 of the NYISO System Operating Procedures.

**Real-Time Zonal LBMP** – The price (in \$/MWh) for combined energy, losses, and transmission congestion determined on a roughly five-minute basis in the real-time electricity market.

**Remote Metering** - Metering equipment, which allows for remote collection of metering data.

**Special Case Resource** - Loads capable of being interrupted upon demand, and distributed generators, rated 100 kW or higher, that are subject to special rules set forth in the NYISO Services Tariff, in order to facilitate their participation in the Installed Capacity market as Installed Capacity Suppliers.

**Zone** - One of eleven geographical areas located within the NYCA that is bounded by one or more of the fourteen New York State Interfaces. During the implementation of the LBMP Markets, all Loads located within the same Load Zone pay the same Day-Ahead LBMP and the same Real-Time LBMP for Energy purchased in those markets.

## 2.0 Program Summary

---

The *Emergency Demand Response Program* (EDRP) provides a mechanism for load reduction during emergency conditions, more specifically defined in this document, thereby facilitating the reliability of the New York State bulk power system.

Retail end users who agree to participate in the EDRP can be accommodated through one of four types of Curtailment Service Providers (CSPs):

- Load Serving Entities (LSEs), either that currently serving the load or another LSE,
- Through NYISO-approved Curtailment Customer Aggregators
- As a Direct Customer of the NYISO
- As a NYISO-approved Curtailment Program End Use Customer

Curtailment Customer Aggregators and Curtailment Program End Use Customers must register with the NYISO as Limited Customers as defined in Section 4.0.

CSPs should be able to provide load reduction of at least 100 kW per Zone and be able to respond within two hours of emergency notification.

Participation in the EDRP is voluntary and no penalties attach if a CSP fails to respond to a NYISO notice to reduce load.

~~R~~Retail end users participating in the EDRP ~~may also cannot~~ participate in the NYISO's Special Case Resources Program, ~~if otherwise qualified~~.

The NYISO will allow ~~up to 25 MW of program~~ participation by aggregations of smaller customers, the curtailed usage of which will be determined by using an alternative to the basic provisions regarding the metering and measurement of performance. DG and self-generation resources are not eligible. Direct serve customers are also prohibited from operating under alternative performance measures. Section 3.8 describes the details of this program option.

CSPs will be given notice no less than two hours in advance of the time specified to reduce load, pursuant to NYISO emergency operations procedures. If the ISO activates the Emergency Demand Response Program for more than four hours, each CSP shall be paid the higher of \$500/MWh, or the zonal Real-Time LBMP per MWh of demand reduced, starting with the hour specified by the ISO as the starting time of the activation, or, in the event that the ISO specified that the demand reduction begin as soon as possible, starting with the hour that the CSP began its response.

If the ISO activates the EDRP for four hours or less, each CSP shall be paid as if the EDRP had been activated for four hours. Each CSP that reduces demand shall be paid the higher of \$500/MWh or the zonal Real-Time LBMP per MWh of demand reduced, for the duration of the ISO activation of the EDRP or for two hours whichever is greater, starting with the hour specified by the ISO as the starting time of the activation, or, in the event that the ISO specified that the demand reduction begin as soon as possible, starting with the hour that the CSP began its response. Each CSP shall be paid the zonal Real-Time LBMP per MWh of demand reduced for the remainder of the four-hour minimum payment period, provided that a verified demand reduction was effectuated by the time specified in the ISO's notice.

A detailed explanation of payments can be found in Section 6.

The program will be effective May 1, 2001 and will continue through October 31, ~~2002~~2005. At the end of each Capability Period, the program will be evaluated and changes recommended as necessary.



## 3.0 Eligibility Criteria / Participant Qualification

---

### 3.1 Effective Period of the Program

The program begins on May 1, 2001, and will continue through October 31, ~~2002~~2005. At the end of each Capability Period (May-October and November-April), program performance will be evaluated to see if any rules and procedures need to be modified.

Entities wishing to participate may apply for entry into the program at any time. ~~If you are also planning to qualify as a Special Case Resource you should review the rules and regulations that apply to Installed Capacity (ICAP) suppliers found in [1], or contact NYISO Market Relations.~~

### 3.2 Who Can Participate?

The EDRP allows wholesale electricity market participants to subscribe retail end users able to provide Load Reduction (Demand Side Resources) when called upon during emergency conditions. Wholesale market participants are grouped into four broad classes of *Curtailment Service Providers* (CSPs):

- *Load-Serving Entities* (LSEs) as defined in [2] that currently serve retail end users capable of load reduction, or an LSE that subscribes another LSE's load solely for the purpose of participating in the NYISO EDRP. LSEs may claim load reductions from their retail end users or the retail end users of another LSE. Load curtailment programs currently in place or under implementation may directly qualify for the EDRP (see 3.4 Restrictions below).
- *Direct Customers* of the NYISO as defined in [2] may claim their own load reductions.
- NYISO-approved *Curtailment Customer Aggregators* (Aggregators) of retail end users capable of load reduction. Aggregators may claim load reductions from Demand Side Resources with which they have a contractual arrangement. An Aggregator is required to join the NYISO as a NYISO Limited Customer.
- NYISO-approved *Curtailment Program End Use Customers* (EUC), end-use customers whose load is normally served by an LSE but who wish to participate directly with the NYISO solely for purposes of the EDRP. EUCs must be capable of reducing at least 100 kW of load. An EUC is required to join the NYISO as a NYISO Limited Customer.

Participation in the EDRP is voluntary; no penalties are imposed upon CSPs or Demand Side Resources for not responding to load reduction requests.

### 3.3 Minimum Qualifications for CSPs

To serve as a CSP, you must:

- 1) Be a NYISO Customer (in the case of LSEs and Direct Customers) or a NYISO Limited Customer (in the case of Aggregators and EUCs) of the NYISO and be able to pledge Load Reduction in the NYCA.
- 2) Be able to completely disconnect from the local distribution system and supply required load via local generators<sup>1</sup> or to reduce a measurable and verifiable portion of the load.
- 3) Be capable of reducing at least 100 kW of load per Zone.

---

<sup>1</sup> These generators either can be non-synchronized to the grid or synchronized to the grid with no net export to the grid while serving load.

- 4) Be capable of responding within two hours of notice from the NYISO.
- 5) Follow the registration procedures defined in Section 4 of this manual.
- 6) CSPs are required to provide hourly interval metering data to validate performance; specific metering requirements are given in Section 6 of this manual.

### 3.4 Restrictions

An individual Demand Side Resource can subscribe to either EDRP or the ICAP SCR program, but not both.

To participate in the program, an individual Demand Side Resource cannot subscribe the same metered load with more than one CSP.

Retail end users under a contract that prevents them from curtailing energy are prohibited from participating in the program. The NYISO will consult with the appropriate LSE and Electric Distribution Company to verify that the load to be reduced is not under any other specific contractual obligation that would prevent participation in the EDRP.

### 3.5 Requirements for Curtailment Customers With Local Generation

Owners of on-site and emergency generators including, but not limited to hospitals, data centers, office buildings, warehouses and industrial locations are eligible to participate in the EDRP. Local Generation will serve all or part of what otherwise would be NYISO load (i.e., the retail end user's specific load delivered from their LSE), thereby reducing the total NYISO load during declared emergencies. The requirements for participation are as follows:

- 1) The generator may operate non-synchronous or synchronous with the grid as long as there is no net electric export while serving the load.
- 2) Be capable of responding within 2 hours of a request to reduce load.
- 3) Must have an integrated hourly or permanent recording meter as described in Section 6.1, Metering Requirements.
- 4) Be capable of receiving notification from a Curtailment Service Provider (CSP).
- 5) On-site generators must supply evidence that they have applied for or received from the NYS Dept. of Environmental Conservation (DEC) one of the following permits (i) Title V, (ii) State Facility, or (iii) Registration.
- 6) Demand Side Resources that will use on-site generators to reduce load and that have Load Banks for testing purposes must ensure that the Load Bank is not operating during the hours required by the EDRP.

Nothing in the EDRP expands or reduces the rights or obligations a Local Generator may have to buy or sell energy into the wholesale market.

### 3.6 Compatibility with ICAP Special Case Resources

The EDRP pays for energy during times of emergency, but does not pay for capacity. The NYISO has a separate program called Special Case Resources (SCR) within the Installed Capacity (ICAP) market that pays for capacity and energy. SCR is available to generators and load reduction providers that meet testing, metering and other requirements. The capacity payments under SCR and the EDRP energy payments are additive. While there are no penalties for non-performance as an EDRP provider, the SCR program will reduce future capacity payments if the NYISO calls for operation and the SCR does not perform. In the event that the NYISO activates SCR to reduce their consumption of energy in accordance

with the criteria set forth in Section 5, the NYISO ~~will~~may activate the EDRP. See the ICAP Manual located at [www.nyiso.com/markets/icapinfo.html](http://www.nyiso.com/markets/icapinfo.html) for more details on SCR.

### **3.7 Compatibility with LSE-Sponsored Curtailment Programs**

There are curtailment programs in New York State both currently in place and under development that are designed to help the local utility with distribution load management. Each program is aimed at enhancing the reliability of the local electric system during time of high usage or outages. The EDRP is designed to be compatible with these programs.

Demand Side Resources may participate in both the EDRP and the Day-Ahead Demand Reduction Program (DADRP) offered by the NYISO. If an EDRP event is called and a Demand Side Resource is participating in both programs, payments will be made as follows:

- 1) If the Demand Side Resource has not had a demand reduction bid accepted in the Day-Ahead Market for the day of the EDRP event, demand reduction provided as a result of the EDRP event call will be paid in accordance with the rules set forth in this manual.
- 2) If the Demand Side Resource is responding to the schedule determined from the bid accepted in the Day-Ahead Market, payments will be made in accordance with the DADRP rules up to the demand reduction scheduled in the Day-Ahead Market. Additional verified demand reduction above that scheduled in the Day-Ahead Market will be paid in accordance with the rules set forth in this manual.

### **3.8 Limited Small Customer Aggregation**

1. Aggregations must be at least 0.5 MW for EDRP. The NYISO will establish an up-front means of certifying that the aggregation has an expectation of meeting this requirement. This will be established as part of the approval of the verification methodology; the sampling plan or other measurement methodology will assign an initial (a priori deemed) estimate of the response per site in order to drive the sample size. The aggregation can be comprised of two or more different sampling methods, provided that such a super aggregation was allowed by the NYISO. The MW limit can also be met by combining participants enrolled by different brokers (CSP or LSE) provided that the brokers agree to submit all participants under a single program entity.

2. Aggregations receive an initial settlement of 75% of the deemed response. For any event that results in payments to participants of an aggregation, the NYISO will pay out 75% of the amount determined by applying the curtailment payment rates to the a priori deemed performance level as defined in (1) above in the normal course of settlements for PRL program participants. At the end of the contract term under which the aggregation was approved, and after all required analyses have been conducted, the NYISO will perform a final settlement assessment and pay out or demand payment of the amount determined by that settlement assessment process.

3. Aggregators must accept full responsibility for payments to and penalties levied against the members of the aggregation. The NYISO will require that each member of the aggregation execute an agreement to participate indicating that it accepts the provisions of the ISO program and authorizes the LSE/CSP to act as its broker for the purposes of participation

4. Proposals for measuring aggregation performance can involve one of several methods:
- a. The deployment of approved whole-premise kW metering devices on a sample of participants
  - b. The deployment of approved end-use device or process kW metering devices on a sample of participants that elect to limit PRL program participation to specified end-use devices or processes.

- c. Provision for supplying verifiable behavioral actions, equipment operating logs, or other data that is deemed to be sufficiently indicate the load level the customer otherwise would have consumed, but for the PRL program event participation
- d. Other measurement systems that indicate the load level the customer otherwise would have consumed, but for the PRL program event participation

5. Promulgate provisions that govern applications. A process and procedures will be drawn to govern how applications are made, processed and ruled upon, and to set limits to aggregation projects by zone, provider, program, or any other category. The number of aggregations allowed needs to accommodate all of the utilities plus a reasonable number of CSPs and LSEs. Each proposal for small customer aggregation will be reviewed by the NYISO staff and the Price Responsive Load Working Group, and must be approved by a majority of the Chairs and Vice-Chairs of the Management Committee and Business Issues Committee and the Chairman of the Price Responsive Load Working Group.

~~6. Aggregations may be declared as ICAP or UCAP. For the purposes of ICAP and UCAP, the use of statistical verification as approved for this program will be an acceptable alternative to interval metering.~~

~~7.6.~~ The Aggregation broker is responsible for all costs associated with developing and administering the alternative performance methodology. Applications for approval of alternative methodologies must include a explicit description of the methodology and how it would be tracked and administered, accompanied by the specific administration processes required. The NYISO in approving an application will specify the costs associated with administration that the applicant must bear. The aggregation applicant must agree to be responsible for all such costs, including costs incurred by the ISO for developing and administering the alternative methodology. The ISO may, at its discretion, require that some or all of such cost be reimbursed by the applicant upon approval of the methodology, or deduct all costs from payments for curtailments by participants, or a combination of the two methods of cost recovery.

8. One method per end-use premise. End-use electricity customers may subscribe load at a given premise to PRL programs only under a single performance methodology, either the standard method or an approved alternative methodology.

9. Failure to comply with aggregation procedures. The NYISO may, at any time, terminate its agreement with an aggregation broker if it determines that the broker is not fulfilling its obligation under the aggregation agreement. Customers belonging to such aggregation may henceforth participate by signing up under any approved means of participation.

### 3.9 EDRP Program Evaluation

Curtailment Service Providers **must** participate in any NYISO sponsored EDRP program evaluations.

## 4.0 CSP Registration Procedures

---

To qualify as a Curtailment Service Provider (CSP) you must be an LSE, Direct Customer, Curtailment Customer Aggregator or Curtailment Program End Use Customer. The registration form is posted on the NYISO web site ([www.nyiso.com](http://www.nyiso.com)) and included in Attachment A to this manual. The general requirements for each CSP class are as follows:

### 4.1 Load Serving Entities (LSE)

For LSE's that are enrolling a retail end user whose load is served by the LSE:

1. Complete Attachment A of this manual.
2. Register each Demand Side Resource with the NYISO after signing a contract using the EDRP Certification form provided in Attachment B of this manual. Any information on the identity of a Demand Side Resource that is provided to the NYISO will be treated as confidential, and will not be disclosed to third parties without the express permission of the end-use customer, unless aggregated or otherwise presented in such a way as to preserve confidentiality.
3. By submitting the EDRP Certification Form, the LSE confirms that the load to be reduced is not under any specific contractual obligation that would prevent participation in the EDRP.
4. The EDRP participant registration is deemed approved 14 calendar days after LSE— submission of Attachment B for each retail end user unless the NYISO contacts the LSE via phone or e-mail to the contrary.

For LSE's that are enrolling a retail end user whose load is served by a different LSE:

1. Complete Attachment A of this manual.
2. Register each Demand Side Resource with the NYISO after signing a contract using the EDRP Certification form provided in Attachment B of this manual. Any information on the identity of a Demand Side Resource that is provided to the NYISO will be treated as confidential, and will not be disclosed to third parties without the express permission of the end-use customer, unless aggregated or otherwise presented in such a way as to preserve confidentiality.
3. Within 2 days after receipt of the EDRP Certification Form, the NYISO will forward the registration to the appropriate LSE and Electric Distribution Company to confirm that the load to be reduced is not under any specific contractual obligation that would prevent participation in the EDRP.
4. The EDRP participant registration is deemed approved in 14 calendar days after notification is provided to the LSE unless the NYISO contacts the LSE via phone or e-mail to the contrary.

### 4.2 Direct Customers

Direct Customers of the NYISO should fill out Attachment A and one copy of Attachment B.

### 4.3 Curtailment Customer Aggregators

5. Curtailment Customer Aggregators are companies that work with owners of generation and load reduction to make it easier to participate in the NYISO Emergency Demand Response program. To register as a Curtailment Customer Aggregator, you must become at least a NYISO Limited Customer. If you are applying for NYISO Limited Customer status as a Curtailment Customer Aggregator and will only be a seller to the NYISO:

1. Complete Attachment A of this manual.

2. Complete Sections A, B, F, G, H, J and K of the NYISO Registration Packet, available at the NYISO website
3. Sign the Market Services Tariff.
4. Register each Demand Side Resource with the NYISO after signing a contract using the EDRP Certification form provided in Attachment B of this manual. Any information on the identity of a Demand Side Resource that is provided to the NYISO will be treated as confidential, and will not be disclosed to third parties without the express permission of the end-use customer, unless aggregated or otherwise presented in such a way as to preserve confidentiality
5. Within 2 days after receipt of the EDRP Certification Form, the NYISO will forward the registration to the appropriate LSE and Electric Distribution Company to confirm that the load to be reduced is not under any specific contractual obligation that would prevent participation in the EDRP.
6. The EDRP participant registration is deemed approved in 14 calendar days after notification is provided to the LSE unless the NYISO contacts the Curtailment Customer Aggregator via phone or e-mail to the contrary.

The application process can take up to 30 days.

#### **4.4 Curtailment Program End Use Customer (EUC)**

An EUC is any Local Generation owner or retail end user capable of interrupting load that can reduce at least 100kW in a zone and wants to participate in the EDRP directly with the NYISO.

If you are applying for NYISO Limited Customer status as an EUC and will only be a seller to the NYISO:

1. Complete Attachment A of this manual.
2. Complete Sections A, B, F, G, H, J and K of the NYISO Registration Packet, available at the NYISO website
3. Sign the Market Services Tariff.
4. Register each Demand Side Resource with the NYISO after signing a contract using the EDRP Certification form provided in Attachment B of this manual.
5. Within 2 days after receipt of the EDRP Certification Form, the NYISO will forward the registration to the appropriate LSE and Electric Distribution Company to confirm that the load to be reduced is not under any specific contractual obligation that would prevent participation in the EDRP.
6. The EDRP participant registration is deemed approved in 14 calendar days after notification is provided to the LSE unless the NYISO contacts the EUC via phone or e-mail to the contrary.

The application process can take up to 30 days.

## 5.0 Operating Mechanism / Implementation

---

### 5.1 When Will the Program be Called?

The EDRP is limited to when called by the NYISO as a part of the In-day Peak Hour Forecast response to an Operating Reserve Peak Forecast Shortage as defined in [3]. The EDRP ~~will~~ may be called in conjunction with Special Case Resources.

The NYISO will invoke the EDRP as one of its emergency procedures in conjunction with the In-day Peak Hour Forecast response to an Operating Reserve Peak Forecast Shortage, as defined in [3], or in response to the Major Emergency state as defined in [4]. Day-ahead notice of a potential operating reserve shortage shall be provided to CSPs when possible. The program is intended to support the New York State power system during emergency periods and the NYISO reserves the right to use its discretion in calling upon EDRP resources to relieve system or zonal emergencies.

The NYISO will declare an Alert State, or Major Emergency for real-time shortage of Operating Reserve, and activate all available in-state generating resources to re-establish the Operating Reserve. If required levels of real-time Operating Reserves cannot be re-established, the NYISO will utilize the EDRP to re-establish real-time Operating Reserves.

### 5.2 NYISO Protocol for Local Generator Participation

This section describes the circumstances under which state agencies, state authorities, regulated utilities, and non-regulated CSPs may contract with customers who agree to reduce demand on the electricity grid by offloading all or a portion of their own power needs through the operation of emergency generators.

This protocol was agreed upon by the New York Public Service Commission (PSC), New York Department of Environmental Conservation (DEC), New York Energy Research and Development Agency (NYSERDA), New York Power Authority (NYPA), Long Island Power Authority (LIPA), and the NY Independent System Operator (NYISO).

~~It is understood that prior to Summer 2002, the~~ The terms and conditions contained in this protocol are intended to be incorporated into utility demand reduction programs regulated by the PSC and are to be made preconditions to participation in the Emergency Demand Response Program (EDRP) by the NYISO.

#### 5.2.1 Program Limitations

Self-generation customers participating in the program will be activated only by the NYISO emergency demand response program, or the transmission owner (TO) in the event of a localized distribution emergency.

Self generation operated in response to either an EDRP or a TO call shall be limited to no more than 200 hours annually.

All facilities with generators that will respond to a "call" for self-generation under the program must be subject to one of the following: (i) a DEC Title V permit, (ii) a DEC state facility permit, or (iii) a DEC facility registration. For those generators registered in EDRP prior to May 2, 2002, evidence of application for or receipt of the appropriate DEC permit must be submitted to the NYISO by May 1. Generators applying for EDRP registration after May 1, 2002 should submit evidence that they have applied for or received the appropriate DEC permit at the time they submit their EDRP registration to the NYISO

Wherever supplies are available for delivery, program participants utilizing diesel fueled emergency generators will use ultra-low sulfur diesel fuel in generators that will be activated in response to a call, as well as for testing purposes. Program participants, not the NYISO, are responsible for ensuring compliance with the ultra-low sulfur fuel requirement. This fuel requirement applies to all tank fills made during the calendar year in which the customer has contracted to participate in the program. NYSERDA will make the determination as to when supplies are available for purposes of this guideline.

Where a supply of ultra-low sulfur fuel is not available for delivery and a state agency is the project sponsor, the participating state agency will mitigate the use of regular diesel fuel by purchasing ultra-low sulfur fuel for displacement of regular diesel fuel at a level that is no less than three times the amount of regular diesel fuel that would be expected to have been consumed by generators participating in its emergency self-generation program.

In addition to the above mitigation measures, the program will be limited to:

- a). Model year 1995 or newer generators; or
- b). Model 1994 and older generators must demonstrate, either by generator-specific manufacturer's data or through emissions testing, that NOx emissions do not exceed 35 pounds per megawatt-hour (lb/MWh). Emissions testing methods for "test and tune" purposes should be conducted consistent with industry established protocols (such as the American Society of Testing and Materials [ASTM] D6522-00) and applicable DEC regulations.

Program participants, not the NYISO, are responsible for ensuring compliance with the emissions testing requirements for model 1994 and older generators.

#### 5.2.2 — Reimbursement of Expenses

~~NYSERDA will reimburse System Benefits Charge (SBC) eligible customers up to 100% of qualifying costs for expenses involved in preparing for participation in the program. For all non-SBC eligible customers, expenses will be reimbursed by the participating state agency or authority as provided for in the respective demand reduction program.~~

~~Eligible expenses include; testing and tuning of emergency generators, advanced metering, communications and control devices, rewiring circuits, installation of transfer switchgear, environmental permitting, selective catalytic reduction technologies, stack modification, operational improvements, cost differential (if any) for use of ultra-low sulfur fuel, and implementation of advanced dual-fuel options.~~

### **5.3 Notification Procedures**

~~When the NYISO activates the Emergency Demand Response Program (EDRP) and/or calls upon the ICAP Special Case Resources, a specific set of messages will be sent to Curtailment Service Providers (CSPs). A CSP will be asked to take certain actions in response to NYISO notification. This section describes the contact procedures and actions that will be requested of CSPs.~~

~~The time frame for advisory and activation notices will be a function of the degree of warning the NYISO has in identifying and responding to operating reserve shortages / major emergencies.~~

~~Notification from the NYISO will always take place via two communications media:~~

- ~~1. A burst e-mail message to EDRP participants requesting specific action. If you participate in both the SCR and EDRP programs, you will receive two e-mail messages for verification purposes.~~



~~2. Phone calls will be made, beginning with the main contact, and proceeding down the list of contacts in an attempt to make a connection. If necessary, the NYISO will call additional cell phone and pager numbers in an attempt to make a connection.~~

~~In making the phone calls, NYISO staff will identify themselves by name and indicate that the NYISO has activated the EDRP and/or SCR programs, followed by the specific requests below.~~

#### ~~5.3.1 Day Ahead Advisory~~

~~Advisory notice — EDRP resources may be needed tomorrow — please respond via e-mail to [edrp-ser@nyiso.com](mailto:edrp-ser@nyiso.com) within one hour indicating:~~

- ~~If you expect to have resources participating, and~~
- ~~MWs expected, divided into interruptible load and local generation.~~

~~Day-ahead notice does not constitute activation of the EDRP program, and is only meant to be advisory.~~

#### ~~5.3.2 In-Day Advisory~~

~~Advisory notice — EDRP resources may be needed later today between HOURS BEGINNING XX through XX. The NYISO will verify that the program has been enacted as soon as practical. Please respond to [EDRP-SCR@nyiso.com](mailto:EDRP-SCR@nyiso.com) within one hour indicating:~~

- ~~• If you expect to have resources participating, and~~
- ~~MWs expected, divided into interruptible load and local generation.~~

~~In-day notice does not constitute activation of the EDRP program, and is only meant to be advisory.~~

#### ~~5.3.3 Canceling an In-Day Advisory~~

~~At this time, the NYISO does not intend to call upon participants in the Emergency Demand Response and Special Case Resource programs to perform services associated with these programs for today. We thank participants for their timely responses to the Advisory Notifications that were sent this morning.~~

#### ~~5.3.4 Activating EDRP — 2-Hour Notification~~

~~Activation notice — EDRP resources are needed from xx:xx to yy:yy today.~~

#### ~~5.3.5 Activating EDRP — Immediate Notice~~

~~Activation notice — EDRP resources that can respond immediately are needed from xx:xx to yy:yy today~~

#### ~~5.3.6 Extending an EDRP Event~~

~~Continuation notice — the call for EDRP resources will be extended until xx:xx.~~

#### ~~5.3.7 Terminating an EDRP Event~~

~~Termination notice — EDRP resources are no longer needed to respond.~~

When the NYISO activates the Emergency Demand Response Program (EDRP) a specific set of messages will be sent to Curtailment Service Providers (CSPs). A CSP will be asked to take certain actions in response to NYISO notification. This section describes the contact procedures and actions that will be requested of CSPs.

The time frame for advisory and activation notices will be a function of the degree of warning the NYISO has in identifying and responding to operating reserve shortages / major emergencies.

Notification from the NYISO will always take place via two communications media:

- Burst e-mail messages to all listed CSP email addresses.
- Automated phone call to each CSP's main contact phone number.

After receiving an EDRP notification, the CSP should take the following steps:

1. The CSP should assess whether or not he/she has resources that can respond, and the MW level of response by zone.
2. Click on the web link within the notification email that was sent. This will provide a response page. Once the available MW by zone information is entered and submitted, it will automatically be tallied at the NYISO with other CSP responses.
3. If for some reason this link is unavailable, the CSP should contact NYISO Market Services at 518-356-6060 with the information.

If the NYISO does not receive the automated response in a reasonable amount of time, they will call additional CSP cell phone and pager numbers in an attempt to make a connection. In this case, NYISO staff will identify themselves by name and indicate that the NYISO has activated the EDRP program, followed by the specific requests below.

#### 5.3.1 Day-Ahead Advisory

EDRP resources may be needed tomorrow between the hours hh:mm and hh:mm. Zones included in this notification are: A,B,C,D,E,F,G,H,I,J,K,. Please reply within one hour indicating:

- If you expect to have resources participating,
- and MWs expected.

Day-ahead notice does not constitute activation of the EDRP program, and is only meant to be advisory.

#### 5.3.2 In-Day Advisory

EDRP resources may be needed later today between the hours hh:mm and hh:mm. Zones included in this notification are: A,B,C,D,E,F,G,H,I,J,K . Please reply within one hour indicating:

- If you expect to have resources participating,
- and MWs expected.

In-day notice does not constitute activation of the EDRP program, and is only meant to be advisory.

#### 5.3.3 Activating EDRP – 2-Hour Notification

EDRP resources are needed from hh:mm and hh:mm. Zones included in this notification are: A,B,C,D,E,F,G,H,I,J,K

#### 5.3.4 Activating EDRP – Immediate Notice

EDRP resources that can respond immediately are needed from hh:mm and hh:mm. Zones included in this notification are: A,B,C,D,E,F,G,H,I,J,K

#### 5.3.5 Extending an EDRP Event

The call for EDRP resources will be extended until hh:mm. Zones included in this notification are:  
A,B,C,D,E,F,G,H,I,J,K

#### 5.3.6 Terminating an EDRP Event

As of hh:mm EDRP resources are no longer needed to respond. Zones included in this notification are:  
A,B,C,D,E,F,G,H,I,J,K

## 6.0 Metering, Verification, Billing and Settlement

---

### 6.1 Metering Requirements

~~By June 1, 2002~~ CSPs must use certified Meter Service Providers (MSP) or Transmission Owners to install ~~meters~~ and Meter Data Service Providers (MDSP) to read revenue-grade interval meters. Installation of any devices directly connected to the revenue meter, such as totalizers, must be installed by certified MSPs. Non-revenue-grade meters meeting the 2% accuracy requirement as defined in Section 6.1.1 may be installed by CSPs as long as they are certified by a Professional Engineer as meeting ANSI C12 standards and are periodically tested and calibrated in accordance with the standards applicable to MSPs. CSPs must use a certified MDSP to read such meters. Transmission Owner or MDSP certification is required to read the revenue grade meter on load. Acceptable interval metering for Demand Side Resources for load reduction or local generation is described below in Section 6.1.1.

#### 6.1.1 Metering Device Requirements

Meters installed under the 2001 EDRP rules prior to March 20, 2002 can be used as the source of EDRP event reporting data.

Hourly interval metering data is required to validate performance. Demand Side Resources may use non-revenue interval metering devices with an overall accuracy of  $\pm 2\%$  as the source of performance data. For each non-revenue interval meter design used, the CSP will submit certification from the meter manufacturer that the model in question meets the  $\pm 2\%$  accuracy threshold, recognizing errors in:

- Current measurement
- Voltage measurement
- A/D conversion
- Calibration

Such meters would be periodically tested and calibrated in accordance with the standards applicable to MSPs and MDSPs.

Where a revenue meter exists, losses in secondary/service circuits between the revenue meter and the non-revenue interval meter may be compensated for so as to bring the reading within  $\pm 2\%$  of the revenue meter. The CSP must demonstrate compliance through comparison of the revenue and non-revenue meters, or show calculation of losses between the revenue and non-revenue meters.

#### 6.1.2 Metering Configuration Requirements

Premises participating in the EDRP shall subscribe under one of three configurations: Local Generation only, load only, or local generation and load. Integrated hourly metering devices shall be required as follows:

- 1) When a premise subscribes only the Local Generation, an hourly interval meter can be installed to measure the generator's output, or interval metering of the total net load can be used.
- 2) When a premise subscribes only the load, the hourly interval meter shall be installed to meter the entire facility or for totalized load, an hourly interval meter is required for each participating load.
- 3) When a premise subscribes both the Local Generation and load, metering can be configured so as to measure only the load or combined load and generation.

Figure 6.1 illustrates examples of acceptable configurations.

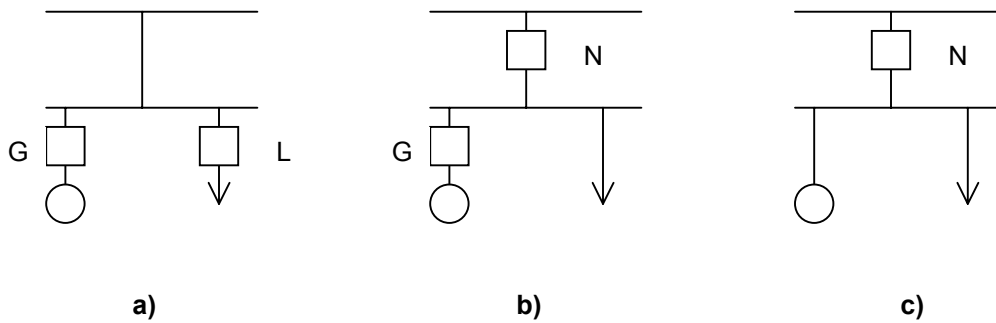

## 6.2 Calculation of Customer Baseline

### 6.2.1 Historical Operating Data

CSPs shall be required to provide historical operating data for each load or on-site generator upon registration for participation in the EDRP. It is the responsibility of the CSP to provide the CBL calculation to the NYISO and ensure that calculations are complete and accurate. These requirements may be met by:

~~1) For Local Generation participating in the NYISO Special Case Resource (SCR) program and the EDRP~~

~~NYISO forms required to qualify as a Special Case Resource will satisfy the requirement for the EDRP program; or~~

~~2) For Local Generation that is only participating the EDRP~~

~~1) For Local Generation that is participating in the EDRP, but not participating in the NYISO Special Case Resource program, the generator meter ID and MSP ID certifying meter installation must be supplied on the End-Use registration form in Attachment B;~~

~~3) For loads with existing interval meters~~

~~Provide a minimum of 1 complete billing period of hourly interval data immediately preceding the first Capability Period the load will participate in;~~

~~4) For totalized loads with existing interval meters~~

~~For totalized loads, provide hourly interval data for a minimum of 1 complete billing period of hourly interval data for all participating loads at the premise; or~~

~~5) For newly installed load interval meters~~

~~For newly installed interval meters, provide the prior three month's summary of monthly kWh MWh consumption and demand values, if available.~~

## 6.2.2 Baseline Calculation Method (Interruptible Load or Both Local Generation and Interruptible Load)

### I. The Average Day CBL

#### A. Average Day CBLs for Weekdays

Step 1. Establish the CBL Window. Establish a set of days that will serve as representative of participant's typical usage.

- A.1.a Determine the participant's peak hourly load over the past 30 days or the period covered by the load data file, whichever is smaller. This value becomes the initial seed value for the *average event period usage level*.
- A.1.b Beginning with the weekday that is two days prior to the event:
  - A.1.b.1 Eliminate any holidays as specified by the NYISO.
  - A.1.b.2 Eliminate any days where the NYISO declared an EDRP event for which the participant was eligible for payment for a curtailment.
  - A.1.b.3 Eliminate any days in which the participant's DADRP curtailment bid was accepted in the DAM, whether or not the participant actually curtailed.
  - A.1.b.4 Create the *average daily event period usage* for that day, defined as the simple average of the participant's actual usage over the hours that define the event for which the CBL is being developed.
  - A.1.b.5 Eliminate low usage days. If the average daily event period usage is less than 25% of the average event period usage level, eliminate that day.
  - A.1.b.6 If the day has not been eliminated, update the average event period usage level by including the average daily event period usage for this day. If this is the first day added to the CBL Window, replace the average event period usage level (which was the initial seed value) with the average daily event period usage. Add this day to the CBL Window.
- A.1.c Move back one day and loop to step A.1.b.1
- A.1.d Final Weekday CBL Window must contain 10 weekdays days.

Step 2. Establish the CBL Basis. Identify the five days from the 10-day CBL Window to be used to develop CBL values for each hour of the event.

- A.2.a Order the 10 days in the CBL Window according to their average daily event period usage level, and eliminate the five days with the lowest average daily event period usage.
- A.2.b The remaining five days constitute the CBL Basis.

Step 3. Calculate Average Day CBL values for the event.

- A.3.a For each hour of the event, the CBL is the average of the usage in that hour in the five days that comprise the CBL basis.

#### B. Average Day CBL for Weekends

Step 1. Establish the CBL Window

- B.1.a The CBL Window is comprised of the most recent three like (Saturday or Sunday) weekend days. There are no exclusions for Holidays or event days.

Step 2. Establish the CBL Basis.

- B.2.a Calculate the average daily event period usage value for each of the three days in the CBL Window.
- B.2.b Order the three days according to their average daily event period usage level.
- B.2.c Eliminate the day with the lowest average value

B.2.d The Weekend CBL Basis contains 2 days.

Step 3. Calculate Weekend Average Day CBL values for the event.

B.3.a For each hour of the event, the CBL value is average of usage in that hour in the two days that comprise the CBL basis.

## II. Elective Weather-Sensitive CBL formulation

Step 1. Calculate the Average Day CBL values for each hour of the event period described in (I) above.

Step 2. Calculate the Event Final Adjustment Factor. This factor is applied to each of the individual hourly values of the Average Day CBL.

A. Calculate the Adjustment Basis Average CBL

2.A.1 Establish the adjustment period, the two-hour period beginning with the start of the hour that is four hours prior to the commencement of the event through the end of the hour three hours prior to the event.

2.A.2 Calculate the Adjustment Basis Average CBL.

2.A.2.a Apply the Average Day CBL formula as described in I. Average Day CBL (page 2), to the adjustment period hours as though it were an event period two hours in duration, but using the five days selected for use in the Average CBL Basis (i.e., average the ten hours).

2.A.2.b Calculate the average of the two usage values derived in 2.A.2.a, which is the Adjustment Basis Average CBL.

B. Calculate the Adjustment Basis Average Usage

2.B.1 The adjustment basis average usage is the simple average of the participant's usage over the two-hour adjustment period on the event day.

C. Calculate the gross adjustment factor

2.C.1 The gross adjustment factor is equal to the Adjustment Basis Average Usage divided by the Adjustment Basis Average CBL

D. Determine the Final adjustment factor. The final adjustment factor is as follows:

2.D.1 If the gross adjustment factor is greater than 1.00, then the final adjustment factor is the smaller of the gross adjustment factor or 1.20

2.D.2 If the gross adjustment factor is less than 1.00, the final adjustment factors are the greater of the gross adjustment factor or .80.

2.D.3 If the gross adjustment factor is equal to 1.00, the final adjustment factor is equal to the gross adjustment factor.

Step 3. Calculate the Adjusted CBL values.

A. The Event Adjusted CBL value for each hour of an event is the product of the Final Adjustment Factor and the Average CBL value for that hour.

## III. Selecting a CBL method

A.1 The participant selects the CBL formula when it registers, or is registered by its LSE or CSP, with the NYISO for program participation. The choice of CBL becomes effective when the NYISO accepts the registration.

A.2 At the initial registration to the PRL program, participants may elect either the Average Day CBL or the Adjusted CBL formula.

A.3 At the time that the new Adjustable CBL formulation becomes effective, registered participants in the PRL program may apply to change to the adjusted formula CBL method beginning thirty (30) days after such notification or to become effective May 1, 2002.

A.4 Participants may switch CBL methods by making application to the NYISO. For such a change applicable to the summer capability period (May 1 – October 31), the application must be submitted to NYISO by April 1. For a change applicable to the winter capability period

(November 1 – April 30), the application must be submitted to NYISO by October 1. The change in the CBL formula becomes effective at the beginning of the next capability period after the NYISO accepts the application.

### 6.2.3 Example Customer Baseline Calculation

As an example, Assume a 4-hour EDRP event was called from 12 noon to 4 pm; notice was sent out at 10 a.m.. The past 10 days MWh consumption for similar hours, along with the four hours prior to event initiation, was:

<b>Time</b>	<b>Day n-2</b>	<b>Day n-3</b>	<b>Day n-4</b>	<b>Day n-5</b>	<b>Day n-6</b>	<b>Day n-7</b>	<b>Day n-8</b>	<b>Day n-9</b>	<b>Day n-10</b>	<b>Day n-11</b>
<b>8-9</b>	5	4	4	4	3	6	2	3	3	4
<b>9-10</b>	5	3	5	4	4	2	3	3	2	4
<b>10-11</b>	7	5	6	5	5	5	4	4	4	5
<b>11-12</b>	8	6	8	6	7	8	5	6	6	7
<b>12-1</b>	10	8	9	7	10	12	5	7	7	8
<b>1-2</b>	11	6	12	8	11	8	8	8	6	10
<b>2-3</b>	7	9	9	6	9	9	8	8	6	9
<b>3-4</b>	5	6	7	6	7	7	6	7	5	6

Steps 1 and 2: sum the MWh for the hours 12-4 each day and select the 5 highest totals:

	<b>MWh n-2</b>	<b>MWh n-3</b>	<b>MWh n-4</b>	<b>MWh n-5</b>	<b>MWh n-6</b>	<b>MWh n-7</b>	<b>MWh n-8</b>	<b>MWh n-9</b>	<b>MWh n-10</b>	<b>MWh n-11</b>
	33	29	37	27	37	36	27	30	24	33
<b>Selected?</b>	Y		Y		Y	Y				Y

Step 3: Calculate the CBL for each hour using the five highest days selected:

<b>Time</b>	<b>Day n-2</b>	<b>Day n-4</b>	<b>Day n-6</b>	<b>Day n-7</b>	<b>Day n-11</b>	<b>CBL</b>
<b>12-1</b>	10	9	10	12	8	9.8
<b>1-2</b>	11	12	11	8	10	10.4
<b>2-3</b>	7	9	9	9	9	8.6
<b>3-4</b>	5	7	7	7	6	6.4

The CBL in the right-hand column above would be the non-weather –adjusted value. If this customer was signed up with the weather-sensitive calculation option, the CBL would be adjusted upward or downward based on the actual usage in the two hours prior to event notification. In this example, the Adjustment Basis Average CBL will be the average of the MWh for hours beginning 8 and 9 over the five days chosen for the CBL:

<b>Time</b>	<b>Day n-2</b>	<b>Day n-4</b>	<b>Day n-6</b>	<b>Day n-7</b>	<b>Day n-11</b>	
<b>8-9</b>	5	4	3	6	4	
<b>9-10</b>	5	5	4	2	4	
<b>Average</b>						4.2

On the day of the event (day n), assume the actual metered load consumption is as shown in the following table:



<b>Hour Beginning</b>	<b>8</b>	<b>9</b>	<b>10</b>	<b>11</b>	<b>12</b>	<b>1</b>	<b>2</b>	<b>3</b>
<b>MWh</b>	4	5	4	3	2	3	3	4

In this case, the Adjustment Basis Average Usage is the average of the MWh in hours 8 and 9, or 4.5 MWh. The Gross Adjustment Factor is the ratio of the Adjustment Basis Average Usage to the Adjustment Basis Average CBL, 4.5/4.2 or 1.07. The CBL will therefore be adjusted upward by 1.07 – the following table shows the resulting new CBL and the computed load reduction for the four-hour event period.

<b>Hour Beginning</b>	<b>12</b>	<b>1</b>	<b>2</b>	<b>3</b>
<b>Load (MWh)</b>	2	3	3	4
<b>CBL (MWh)</b>	10.5	11.1	9.2	6.8
<b>Load Reduction (MWh)</b>	8.5	8.1	6.2	2.8

It is important to note that if the actual usage in the two hours prior to notification was *lower* than the Adjustment Basis Average CBL, the CBL curve would have been shifted *downward* and would result in load reduction performance that was lower than would have been determined using the Average Day CBL (without weather adjustment).

#### 6.2.4 Baseline Calculation Method (Local Generation Only)

For Local Generation using separate metering, a similar CBL calculation is used to eliminate any base load portion of generation from the actual performance during the event.

1. Calculate the Local Generation during similar hours over the past 10 weekdays, beginning two days prior to the curtailment event and excluding days where curtailment due to participation in the EDRP or the Day-Ahead programs occurred.  

$$kwhMWh(k) = \text{sum}(h(i)...h(j)) \text{ for each day } k = d(n-2)...d(n-11)$$
2. Select the 5 **lowest** values of  $kwhMWh(k)$  and use those days  $d(l)$ ,  $l = 1...5$  to calculate the CBL.
3. Calculate the CBL for each hour  $h(i)$  as the average of the five  $h(i)$  values for days  $d(l)$ ,  $l = 1...5$ .

### 6.3 Performance Measurements and Compliance

#### 6.3.1 Performance

Performance for metering configurations where load reduction is included is measured as the difference between the Customer Baseline and the actual metered usage by hour during the event. The Customer Baseline type used for computing performance shall be the same day-type as the day-type of the EDRP event. For Local Generation, the generator output as metered will be used for performance as defined below. The equations are given for the alternative metering configurations shown in Figure 6.1.

#### Load Only Configuration

For premises subscribing only the load, performance for each hour shall be calculated as:

$$P_h = (CB-xx)_h - AL_h \text{ (Meter configuration 6.1a)}$$

$$P_h = (CB-xx)_h - AN_h \text{ (Meter configuration 6.1b and 6.1c)}$$

Where  $P_h$  = performance for the hour

CB-xx<sub>h</sub> = Customer Baseline day-type (weekday – CB-WD, Saturday-CB-SA, or Sunday-CB-SU) for the hour as calculated using the simple average method described above in Section 6.2.2

AL<sub>h</sub> = actual load for the hour using meter L in configuration 6.1a

AN<sub>h</sub> = actual load for the hour using meter N in configuration 6.1b and 6.1c

### Local Generation Only Configuration

For premises subscribing only Local Generation, performance for each hour shall be calculated as:

$$P_h = OG_h - (GCB-xx)_h$$

Where P<sub>h</sub> = performance for the hour

OG<sub>h</sub> = Metered On-site generator output for the hour using meter G in either configuration 6.1a or 6.1b

GCB-xx<sub>h</sub> = Customer Baseline day-type (weekday – GCB-WD, Saturday – GCB-SA or Sunday GCB-SU) for the hour h as determined for Local Generation described in Section 6.2.3.

### Load and Local Generation Configuration

For premises subscribing both the Local Generation and the load and participating in the same EDRP event, performance for each hour shall be the net of Local Generation and load as defined below:

$$P_h = [OG_h - (GCB-xx)_h] + [(CB-xx)_h - AL_h] \text{ (Meter configuration 6.1a)}$$
$$P_h = (CB-xx)_h - AN_h \text{ (Meter configuration 6.1b and 6.1c)}$$

Where P<sub>h</sub> = performance for the hour

OG<sub>h</sub> = Metered On-site generator output for the hour

GCB-xx<sub>h</sub> = Customer Baseline day-type (weekday – GCB-WD, Saturday – GCB-SA or Sunday GCB-SU) for the hour h as determined for Local Generation described in Section 6.2.3.

CB-xx<sub>h</sub> = Customer Baseline day-type (weekday – CB-WD, Saturday-CB-SA, or Sunday-CB-SU) for the hour as calculated using the simple average method described above in Section 6.2.2

AL<sub>h</sub> = actual load for the hour using meter L in configuration 6.1a

AN<sub>h</sub> = actual load for the hour using meter N in configuration 6.1b and 6.1c

## 6.3.2 Compliance

### Initial Compliance

Initial Compliance (IC) is measured as the first event hour in which performance in the hour is greater than zero (actual load is less than baseline).

### Final Compliance (Restored Load)

Final Compliance (FC) is measured as the last hour in which performance is greater than zero, or the last hour of the EDRP event, whichever is earlier.

### Compliance Period

The Compliance Period includes every hour in the EDRP event in which performance was greater than zero, beginning with the Initial Compliance hour and ending with the Final Compliance hour or the end of the EDRP event, whichever is earlier.

Table 6.1 illustrates examples of Initial Compliance and Final Compliance for an event starting at noon and lasting for five hours.

**Table 6.1 - Examples of Performance during an EDRP Event**

NYISO EDRP Event										
	10 - 11AM	11- 12 AM	12 - 1 PM	1 - 2 PM	2 - 3 PM	3 - 4 PM	4 -5 PM	5 - 6 PM	6 -7 PM	
<b>Customer 1</b>										
BL	125	125	125	125	150	150	150	150	125	
AL	130	120	110	100	100	125	150	160	140	
Performance		5	15	25	50	25	0			
			IC	P	P	FC				
Compliance Period										
<b>Customer 2</b>										
BL	200	200	250	250	250	200	200	200	200	
AL	200	200	250	225	200	175	175	175	200	
Performance			0	25	50	25	25	25		
				IC	P	P	FC			
Compliance Period										
<b>Customer 3</b>										
BL	300	300	350	350	350	300	300	300	300	
AL	300	300	350	325	325	325	275	275	300	
Performance			0	25	25	0	25	25		
				IC	P	P	FC			
Compliance Period										
Legend	BL = Baseline		IC = Initial Compliance				P = Performance			
	AL = Actual Load		FC = Final Compliance							

## 6.4 Settlement Procedures

CSPs shall provide verification of load reduced within 45 days of the emergency by providing interval billing meter data to the NYISO. Verification of load reduction not received by the NYISO within 45 days of the emergency may not be compensated pursuant to this program. All load reduction is subject to NYISO audit, and market monitoring unit review. The NYISO will be responsible for settlement payment.

### 6.4.1 Data Submission

A CSP will submit the response(s) of the Demand Side Resource(s) that participated in the emergency event to the NYISO within 45 days of the event being called. Failure to so provide such data will result in a CSP not receiving payment for its participation in the EDRP. In cases where the CSP is not the Meter Data Service Provider (MDSP), upon receipt of the data by the NYISO, the NYISO will immediately forward the data to the MDSP (in most, if not all, cases the Transmission Owner) for optional review. After 14 calendar days the NYISO will accept the data as submitted unless challenged by the MDSP. The ISO maintains the ability to subsequently review the data through the Market Monitoring Unit.

#### 6.4.2 EDRP Reporting

In establishing the reporting requirements for this program, information regarding the identity of Demand Side Resources participating in this program shall be treated as confidential by the NYISO, and will not be shared with third parties.

The Event Participation Report (found in Attachment\_C) or the equivalent .csv file format described in Attachment D shall be required for reporting performance in an EDRP event. Either version is intended to be completed for each load or Local Generation resource participating in a CSP's EDRP program.

#### 6.4.3 Demand Side Resource Reduction Data

A CSP will submit response(s) of the Demand Side Resource(s) or Local Generation that participated in the emergency event aggregated by hour and by zone.

- a) Where the CSP's Demand Side Resource response is based on individual end-use loads alone or for premises with both participating load and Local Generation, the CSP is required to provide metered hourly interval data for each load and the Local Generation for the entire billing period in which the EDRP event occurred.
- b) Where the CSP's Demand Side Resource response is provided only from Local Generation, the CSP shall provide interval data for the 24-hour period ending midnight of the day of the EDRP event.
- c) If the EDRP event occurs less than 10 days into a billing period for any end-use load or premises with participating load and Local Generation, the prior month's bill period data must also be provided for that end-use load and Local Generation.

#### 6.4.4 Data Format

Individual end-use or Local Generation hourly interval load data for the billing period in which an EDRP event occurred shall be submitted in electronic form to the NYISO in one of the following formats:

- a) Excel spreadsheet format (Event Participation Summary Report) as described in Attachment C. A template can be found on the NYISO website at:  
[http://www.nyiso.com/services/documents/groups/bic\\_price\\_responsive\\_wg/demand\\_response\\_prog.html](http://www.nyiso.com/services/documents/groups/bic_price_responsive_wg/demand_response_prog.html)
- b) Comma-Separated Variable format as described in Attachment D.

CSPs should submit one file per day containing meter and CBL data for all participants.

Electronic data files may be submitted via one of the following methods:

- a) e-mail to: [dlawrence@nyiso.com](mailto:dlawrence@nyiso.com) or [edrp-scr@nyiso.com](mailto:edrp-scr@nyiso.com);
- b) CD-ROM or other electronic medium.

## 6.5 Energy Payments

### 6.5.1 Calculation of Payments

The NYISO will calculate the payment to CSPs using the following formula:

***If the Emergency is four hours or longer:***

$$P_h * \max(\$500, \text{LBMP}_{\text{RT Zonal, } h}) \text{ for each hour } h \text{ of the emergency}$$

***If the Emergency is less than four hours:***

$$P_h * \max(\$500, \text{LBMP}_{\text{RT Zonal, } h}) \text{ for each of the first two hours } h \text{ of the emergency, or for the duration of the emergency, whichever is greater (a minimum two-hour payment for performance)}$$

+

$$P_h * \text{LBMP}_{\text{RT Zonal, } h} \text{ for the remainder of the four-hour period.}$$

$P_h$  = performance during hour  $h$  as defined in Section 6.3.1

$\text{LBMP}_{\text{RT Zonal, } h}$  = Real-time zonal LBMP for hour  $h$

In most cases, NYISO Operators will specify a start and end time for the curtailment event. This information will be provided at least two hours prior to the starting time. Demand Side Resources will be expected to begin curtailment at the specified starting time. Participants who respond to a notice will be paid for performance in accordance with the above formulas for either the length of the curtailment period or four hours, whichever is greater. The four-hour minimum payment period will begin at the time when the NYISO directs the retail end user to reduce load or, if load reduction is requested as soon as possible, when the retail end user begins his load reduction response.

CSPs that fail to provide load reduction when requested by the NYISO incur no penalties for failure to respond to the EDRP.

### 6.5.2 Distribution of Payments

Payments will be made by the NYISO directly to the CSPs.

Payments will be made by the ISO as part of the monthly bill generated by the ISO. The bill will record the payment as an emergency energy payment and will break down the payment by total kWh/MWh by zone, hourly zonal price, and total payment. These payments will be made to the CSPs for all emergencies which have had data submitted and approved in accordance with the data policy prior to the end of the month.

### 6.5.3 Verification, Errors and Fraud

All load reduction data is subject to audit by the NYISO and its Market Monitoring unit. Disputes concerning erroneous payments shall be resolved through the ISO's Dispute Resolution Procedures.

If the ISO in its review of the CSP's account determines the CSP or one of its customers has committed fraud to extract EDRP payments from the ISO, the ISO will have the right to ban the CSP or the CSP's customer from the EDRP as well as pursue all of the ISO's legal rights, at its sole discretion.

## 6.6 Assessment of Program Charges

### 6.6.1 Objectives of Cost Allocation

The costs for the program will equal the sum of all payments to customers calculated and paid out under Section 6.5.1.

In general, cost allocations should be designed with fairness and market efficiency (i.e., sending the correct price signals) in mind. If it can be determined that some locations provoke the need for a service and/or benefit from that service, then it is proper (from both a fairness and market efficiency perspective) to charge loads in those locations for the service specifically.

In the case of the EDRP, the cost allocation method should be done on a Zonal rather than statewide (i.e., "all loads - every time") basis so that price signals will be produced that help encourage reliability improvements **where** reliability needs to be improved.

### 6.6.2 Causes for EDRP Being Invoked

EDRP will be invoked during situations in which one or both of the following actually occur or are predicted to occur *within a specific Zone or set of Zones*:

#### **EDRP Condition 1**

Internal Load **exceeds** Available (Internal) Generation *plus* Import Capability

*Where* Import Capability equals the lesser of Transmission Import Capability for that Zone (or set of Zones) **OR**  
Supply Available for Import via that Transmission

#### **EDRP Condition 2**

Locational Operating Reserve Requirements **exceed** Available Operating Reserves.

### 6.6.3 EDRP Cost Allocation

Based upon the objectives for cost allocation and the causes for initiating the EDRP (i.e., Conditions 1 and 2 as defined above), the following cost allocation method will be used:

***Costs associated with EDRP will be allocated to all Loads in Zones for which EDRP will directly help to alleviate Conditions 1 and or 2.***

The above rule translates into the following table:

Table 6.2 Emergency Demand Reduction Program Cost Allocation	
Location of Condition 1 and/or 2	EDR Cost Allocation
All or Part of One NYCA Zone (including relief for Local Reliability Rule problems within a Zone as requested by a TO)	All Loads in that Zone ( $L_z$ )
Two or More NYCA Zones	All Loads in those Zones ( $L_{zsum}$ )
All Zones in NYCA	All Loads in NYCA ( $L_{system}$ )
An External Control Area	The External Control Area ( $L_{external}$ )

#### 6.6.4. Cost Allocation Formula

The monthly charge for EDRP payments will be recovered from all Transmission Customers, and will be calculated as the product of (A) payments made to Curtailment Service Providers and (B) the ratio of (i) the customer's billing units for the month to (ii) the sum of all billing units during that month.

Billing units shall be based on the Actual Energy Withdrawals for all Transmission Service to supply Load in the NYCA, and hourly Energy schedules for all Wheels Throughs and Exports. To the extent that the ISO activates the Emergency Demand Response Program in response to an Emergency or a real-time locational Operating Reserves shortage or a peak forecast of an Operating Reserves shortage in a particular zone or zones, including relief to meet a Local Reliability Rule within a zone as requested by a Transmission Owner, the billing units for such charges will be based on the Actual Energy Withdrawals in the affected zone(s) during the hours in which the Emergency Demand Response Program was activated.

LSEs shall also be required to pay the monthly charges calculated above for Transmission Customers, which the LSE serves as retail access customers.

This charge will appear as a distinct line item on the customer bill. The NYISO will separately provide and will have supporting material that will include the amount of load response for each hour of the emergency.

## 6.7 Timeline for Settlement

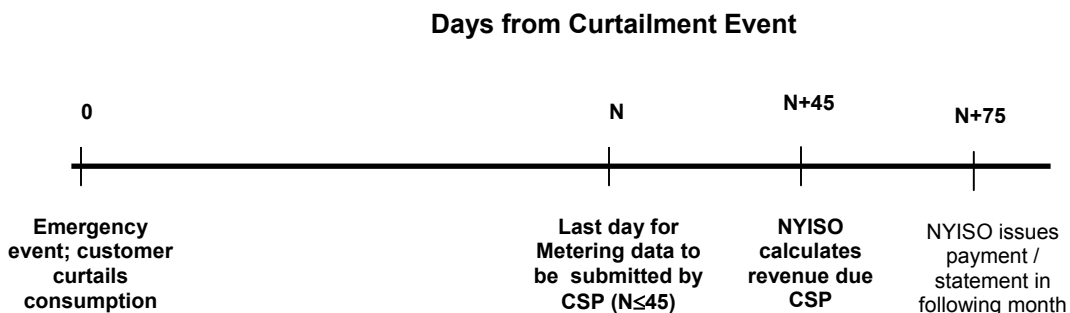

For the month immediately following the calculation of revenues to be paid to the CSP:



- Approximately on 8<sup>th</sup> of following month NYISO bills are generated; costs and revenues will be posted to the CSP and LSE Billing Statements
- Approximately on 16<sup>th</sup> payments are due from the LSEs
- Approximately on 22<sup>nd</sup> revenues will be due from the ISO to the CSPs

## 7.0 References

---

- [1] Stage 2 ICAP Manual ~~for Winter 2001-2002, Dec. 30, 2002~~ (available on NYISO website at [http://www.nyiso.com/services/documents/manuals/pdf/planning\\_manuals/stage2\\_icap\\_manual\\_12\\_30\\_02.pdf](http://www.nyiso.com/services/documents/manuals/pdf/planning_manuals/stage2_icap_manual_12_30_02.pdf) ~~)~~[.http://www.nyiso.com/services/documents/manuals/pdf/planning\\_manuals/icap\\_manual.pdf](http://www.nyiso.com/services/documents/manuals/pdf/planning_manuals/icap_manual.pdf)).
- [2] Market Administration and Control Area Services Tariff (available on NYISO website at <http://www.nyiso.com/services/oatt.html>).
- [3] Section 4.4.1 of the NYISO Emergency Operations Manual (available on NYISO website at [http://www.nyiso.com/services/documents/manuals/pdf/oper\\_manuals/em\\_op\\_pro.pdf](http://www.nyiso.com/services/documents/manuals/pdf/oper_manuals/em_op_pro.pdf))
- [4] Section 3.2 of the NYISO Emergency Operations Manual (available on NYISO website at [http://www.nyiso.com/services/documents/manuals/pdf/oper\\_manuals/em\\_op\\_pro.pdf](http://www.nyiso.com/services/documents/manuals/pdf/oper_manuals/em_op_pro.pdf)).

# Attachment A – Curtailment Service Provider (CSP) Registration

---

## Emergency Demand Response Program (EDRP)

The requirements for EDRP suppliers are controlled by the New York Independent System Operator's Services Tariff ("ISO Services Tariff") and the "NYISO Emergency Demand Response Program Manual".

This form must be faxed to **518-356-6146**, attention: **Manager EDRP** or e-mailed to **dlawrence@nyiso.com** or **edrp-scr@nyiso.com**

---

### Operations Contact Information

All communications by the NYISO during an EDRP event will be sent to the primary and secondary contacts listed below (additional contacts should be provided on a separate sheet).

Primary Contact Name: \_\_\_\_\_  
Organization: \_\_\_\_\_  
Address: \_\_\_\_\_  
\_\_\_\_\_  
\_\_\_\_\_  
Phone: \_\_\_\_\_  
Cell phone: \_\_\_\_\_  
Pager: \_\_\_\_\_  
Fax: \_\_\_\_\_  
E-mail: \_\_\_\_\_

Secondary Contact Name: \_\_\_\_\_  
Organization: \_\_\_\_\_  
Address: \_\_\_\_\_  
\_\_\_\_\_  
\_\_\_\_\_  
Phone: \_\_\_\_\_  
Cell phone: \_\_\_\_\_  
Pager: \_\_\_\_\_  
Fax: \_\_\_\_\_  
E-mail: \_\_\_\_\_

---

**Administrative Contact Information**

All inquiries and notices of an administrative nature by the NYISO will be sent to the address provided below.

Name: \_\_\_\_\_  
Organization: \_\_\_\_\_  
Address: \_\_\_\_\_  
\_\_\_\_\_  
\_\_\_\_\_  
Phone: \_\_\_\_\_  
Cell phone: \_\_\_\_\_  
Pager: \_\_\_\_\_  
Fax: \_\_\_\_\_  
E-mail: \_\_\_\_\_

---

**Check Only One – Which type of organization are you?**

Curtailment Customer Aggregator	Load Serving Entity	Direct Customer	Curtailment Program End Use Customer
<input type="checkbox"/>	<input type="checkbox"/>	<input type="checkbox"/>	<input type="checkbox"/>

---

**Is your organization a current NYISO Customer?** (Check one) Yes  No   
(If no, you must become either a NYISO Customer or a NYISO Limited Customer to participate in this program. See Manual Section 4 for application requirements)  
Please check all the LBMP zone(s) in which you plan to provide a Demand Side Resource:

West <input type="checkbox"/>	Genesee <input type="checkbox"/>	Central <input type="checkbox"/>
North <input type="checkbox"/>	Mohawk Valley <input type="checkbox"/>	Capital <input type="checkbox"/>
Hudson Valley <input type="checkbox"/>	Millwood <input type="checkbox"/>	Dunwoodie <input type="checkbox"/>
NYC <input type="checkbox"/>	Long Island <input type="checkbox"/>	

The CSP certifies that it meets the requirements to be a Curtailment Service Provider and that the information contained in this form and its attachments is complete and correct.

The CSP certifies that the end-use customer has been informed of their enrollment in the EDRP program

Furthermore, the CSP agrees to participate in any NYISO sponsored EDRP Program evaluations.

IN WITNESS WHEREOF, this Curtailment Service Provider's Emergency Demand Response Program Registration has been submitted on this, the \_\_\_\_\_ day of \_\_\_\_\_, 20\_\_.

NAME OF CSP SUPPLIER: \_\_\_\_\_

Name: \_\_\_\_\_

Title: \_\_\_\_\_

\_\_\_\_\_  
Authorized Representative Signature

## Attachment B - Emergency Demand Response Program – End Use Customer Registration

This form can be emailed to [dlawrence@nyiso.com](mailto:dlawrence@nyiso.com) or [edrp-scr@nyiso.com](mailto:edrp-scr@nyiso.com)  
 (Use one form for each Demand Side Resource Registered by the CSP)

**NOTE:** The information in this section is optional.

Organization: \_\_\_\_\_  
 Street Address: \_\_\_\_\_  
 \_\_\_\_\_

### Emergency Demand Response Program (EDRP) Load Certification

Name of energy provider for this Demand Side Resource: \_\_\_\_\_

Name of Local Distribution Company (LDC): \_\_\_\_\_

LDC's Electric Account Number (s) for Demand Side Resource: \_\_\_\_\_

Meter Service Provider: \_\_\_\_\_

Meter Data Service Provider: \_\_\_\_\_

LBMP Zone of Demand Side Resource: \_\_\_\_\_

CBL Choice (check one):       Average Day    Weather Adjusted

Total Facility Load \_\_\_\_\_ MW (rounded to nearest 0.1 MW)

Amount of Interruptible Load \_\_\_\_\_ MW (rounded to nearest 0.1 MW)

For on-Site Generators, Capacity Rating \_\_\_\_\_ MW (rounded to nearest 0.1 MW)

Resource (check one):       on-Site Generator    Interruptible Load    Gen + Int. Load

DEC Permit Status (check one):       Applied for (supply copy of app.)       Registration  
     Permit received (supply copy of permit)       State Facility  
     Title V  
     Federal Bldg.

Type of metering (check all that apply) –

Existing utility interval meter      Meter ID #: \_\_\_\_\_  
 Permanent recording meter on generator / interrupted load      Meter ID#: \_\_\_\_\_  
 Permanent interval meter on generator, if new date installed or to be installed \_\_\_\_\_  
 Meter ID #: \_\_\_\_\_

Attach MSP certification if new meter

Name of Curtailment Service Provider supplying Demand Side Resource: \_\_\_\_\_

Period for which CSP will supply Demand Side Resource: \_\_\_/\_\_\_/\_\_\_ to \_\_\_/\_\_\_/\_\_\_

\_\_\_\_\_  
 Authorized Representative of Curtailment Service Provider

\_\_\_\_\_  
 Date

## Attachment C –

### NYISO Emergency Demand Response Program

#### End-Use Event Participation Form Detailed Instruction

Complete one (1) form for each EDRP Demand Side Resource

This report identifies dates used for the CBL Basis, the CBL calculation dates, and the CBL and actual metered values used to compute the net load reduction/generator output for an EDRP event. The net load reduction/generator output for each participating Demand Side Resource is sent to the NYISO in the EDRP Event Detail Data file.

Participant information section:

<u>Date of EDRP Event</u>	<u>Date EDRP event was called</u>
<u>CSP Name/ID</u>	<u>CSP Name or ID</u>
<u>Name of LSE</u>	<u>Name of Load-Serving Entity for the Demand Resource Side</u>
<u>LSE's Electric Account No.:</u>	<u>LSE's Account number for the Demand Side Resource</u>
<u>Meter Number</u>	<u>Meter identifier</u>
<u>Load Name</u>	<u>Account Name of the Demand Side Resource</u>
<u>NYISO PTID</u>	<u>Point Identifier assigned by NYISO upon registration of the Demand Side Resource</u>
<u>LBMP Zone of EDRP Load</u>	<u>Zone location of the Demand Side Resource</u>
<u>Type of EDR</u>	<u>If this metered account (premise) is using both on site emergency generation and load curtailment for the load reduction, check both boxes. (Formatted as Monotype Sorts – use the 3 key on the keyboard to make a check mark.)</u>
<u>Type of EDR – On Site Generator</u>	<u>Check this box if the Demand Side Resource is using on-site backup generation for load reduction under EDRP. (Formatted as Monotype Sorts – use the 3 key on the keyboard to make a check mark.)</u>
<u>Type of EDR – Interruptible Load</u>	<u>Check this box if the Demand Side Resource will curtail load for load reduction under EDRP. (Formatted as Monotype Sorts – use the 3 key on the keyboard to make a check mark.)</u>
<u>Check box at left if Load is Net Metered</u>	<u>Check this box if this account is net metered. (Formatted as Monotype Sorts – use the 3 key on the keyboard to make a check mark.)</u>

Load Data – CBL Determination Data:

<u>Dates Included in CBL</u>	<u>Enter the 10 days used as a basis for selecting the 5 days that make up the CBL – reverse chronological order (most recent day first)</u>
<u>Basis for this EDRP event</u>	
<u>Dates used for this EDRP event (check max. of 5)</u>	
<u>Dates Excluded:</u>	
<u>Reason</u>	<u>Enter Reason Code. If O – Other is used, also specify the reason the date was excluded from the CBL Basis</u>

<u>Reason Codes</u>	<u>Four (4) possible codes:</u> <u>E – EDRP participation</u> <u>D – DADRP participation</u> <u>S – Shutdown-calculated using NYISO provision</u> <u>O – Other – include a specific reason when using Other</u>
---------------------	---

Event Performance reporting section:

Col. A – CBL: Fill in simple average for each hour (CBL)	Enter the 24 hourly values that make up the computed CBL (Col A1 for Load and Col A@ for Metered On-site Generation)
Col. B – LOAD: Fill in only EDRP event hours with actual meter readings	Enter the actual meter readings for the hours of the EDRP event
Col. C – GENERATION: Fill in only EDRP event hours with actual meter readings	Enter the generation output values (for EDRP event hours only) for the separately metered on-site emergency generation used during the EDRP event
Col. D – Hourly Performance: Fill in only EDRP event hours	Compute the Hourly Performance using the appropriate calculation shown in the Hourly Performance Calculation box at the bottom of the column – EDRP event hours only
Prepared by:	Enter the name and contact information for the individual preparing the form

Date of EDRP Event: \_\_\_\_\_

NYISO PTID:

Program (EDRP or SCR): \_\_\_\_\_

LBMP Zone of EDRP Load:

CSP/RIP Name/ID: \_\_\_\_\_

Name of LSE: \_\_\_\_\_

LSE's Electric Acct. No: \_\_\_\_\_

Type of EDR: (check all that apply)

Meter Number: \_\_\_\_\_

On-site Generator

Load Name: \_\_\_\_\_

Interruptible Load   Check box at left if Load is Net Metered

CBL Method: (check one) Average

Weather-Sensitive

Enter all values rounded to .001 MWh

**Load Data - CBL Determination Data**

Dates included in CBL Basis for this EDRP Event (mm/dd/yy in reverse chronological order)

Dates used for this EDRP event (check max. of 5)

1.		
2.		
3.		
4.		
5.		
6.		
7.		
8.		
9.		
10.		

(Enter all dates excluded that should otherwise be included in the CBL Basis for this event and a Reason Code for each date.)

**Dates Excluded: Reason:**

1.		
2.		
3.		
4.		
5.		
6.		
7.		
8.		
9.		
10.		
11.		
12.		
13.		
14.		
15.		
16.		
17.		
18.		
19.		
20.		
21.		
22.		
23.		
24.		
25.		

	A1	A2	B	C	D
Hour of Day (hour beginning)	CBL - LOAD: Fill in simple average for each hour (CBL)	CBL - Metered On-site Generation: Fill in simple average for each hour (CBL)	LOAD: Fill in only EDRP event hours with actual meter readings	GENERATION: Fill in only EDRP event hours with actual meter readings	Hourly Performance: (fill in only EDRP event hours)
0					
1					
2					
3					
4					
5					
6					
7					
8					
9					
10					
11					
12					
13					
14					
15					
16					
17					
18					
19					
20					
21					
22					
23					
24*					

**Reason Codes:**  
**E** EDRP Participation  
**D** DADRP Participation  
**S** Shutdown-use NYISO rule  
**O** Other - must specify

\*The extra hour that appears at the time shift from DST to EST will be after the first hour beginning 2 and the missing hour that occurs during the time shift from EST to DST will be represented by an empty field. For example, the hours will appear as 1,2,2,3,... and 1,3,4,...

**Hourly Performance Calculations**  
 Load only = col. A - col. B  
 Generation only (metered) = col. A2 - col. C  
 Generation only (NET metered) = (col. A - col. B)  
 Load and generation (NET metered) (col. A - col. B)  
 Load and generation (separately metered) (col. A1 - col. B) + (col. C - col. A2)

Prepared by: \_\_\_\_\_ Date: \_\_\_\_\_  
 Phone: \_\_\_\_\_ Fax: \_\_\_\_\_  
 E-mail: \_\_\_\_\_



## Attachment D - .csv File Format for EDRP

The file format defined below can be used as an alternative to the spreadsheets found in Appendix D of the EDRP Manual for reporting event data to the NYISO. The format is intended to simplify the transfer of data from CSP's CBL and load reduction calculations to the NYISO's billing and accounting process.

The extra hour that appears at the time shift from DST to EST will be after the first hour beginning 2 and the missing hour that occurs during the time shift from EST to DST will be represented with one comma. For example, the hours will appear as 1,2,2,3,... and 1,3,4,... This format is only for EST/DST time change, all other times the file will follow the format below.

### Procedure for Submitting Files Subsequent to an EDRP Event

CSPs can submit either the Excel spreadsheet file defined in Attachment C of the EDRP Manual or the .csv file defined in this Attachment. The table below identifies the types and numbers of files that should be submitted for each event.

Type of information	Appendix D Spreadsheet	.csv file
End-Use Event Form	one sheet per demand side resource participating in event	one file per demand side resource participating in event*

\*CSPs should zip all End-Use Event Files into one file prior to submitting to the NYISO

Files should be e-mailed to either of the following addresses:

[dlawrence@nyiso.com](mailto:dlawrence@nyiso.com)

[edrp-scr@nyiso.com](mailto:edrp-scr@nyiso.com)

## Demand Side Resource Event Form

The Demand Side Resource event form mirrors the information specified in the End Use Participation Form found in Attachment C of the EDRP Manual. CSPs should complete one Demand Side Resource event form for each Demand Side Resource that participated in the EDRP event.

File Name (EDRP Event Data): CSPID\_EDRPmmdyyy.csv

CSPID: Each CSP will receive a CSP ID upon registration. The CSP ID will be used as part of file names for reporting EDRP event data.

PTID: Each End-Use will receive a PTID (PoinT Identifier) upon registration. The PTID will be used to identify the Demand Side Resource participating in the EDRP event.

mm = month (01-12)  
dd = day (01-31)  
yyyy = year (1999 - 2099)

The load values will be sent to a precision of three decimal digits.

*Note: For readability, the format shown below includes spaces after each comma; the data file should not include spaces after each comma.*

Example: Demand Side Resource Event Occurring on May 4, 2001

Filename, \_\_\_\_\_,

Program, EDRP, 0, ICAP/SCR, 1

CSP/RIP Name, Curtailment Service Provider,

NYISO PTID, xxx001,

LBMP Zone of EDRP Load, C,

Type of EDRP, On-site Generator, 0, Interruptible Load, 1, Load is Net metered, 1,

Load data - CBL Determination Data,

CBL Adjustment, Normal, 0, Weather-Sensitive, 1

Dates included in CBL

Basis, 5/2/2001, 5/1/2001, 4/30/2001, 4/27/2001, 4/26/2001, 4/25/2001, 4/24/2001, 4/23/2001,

4/13/2001, 4/12/2001,

Dates used for this EDRP event, 1, 1, 1, 0, 0, 1, 1, 0, 0,

Dates Excluded that should otherwise be included in the CBL Basis for this

event, 4/20/2001, 4/19/2001, 4/18/2001, 4/17/2001, 4/16/2001,

Reason dates excluded that should otherwise be included in the CBL Basis for this

event, Shutdown, Shutdown, Shutdown, Shutdown, Shutdown,

Hour of Day (hour

ending), 1, 2, 3, 4, 5, 6, 7, 8, 9, 10, 11, 12, 13, 14, 15, 16, 17, 18, 19, 20, 21, 22, 23, 24, 25

LOAD Fill in simple average for each hour

(CBL), 1.1, 1.1, 1.2, 1.2, 1.2, 1.2, 1.2, 1.3, 1.3, 1.4, 1.4, 1.5, 1.5, 1.6, 1.6, 1.6, 1.6, 1.6, 1.5, 1.5, 1.4, 1

.3, 1.2, 1.1

Metered on-site generation Fill in simple average for each hour (CBL),

LOAD Fill in only EDRP event hours with actual meter

readings, , , , , , , , , , , 1.3, 1.14, 1.1, 1.1, 1.1,

GENERATION: Fill in only EDRP event hours with actual meter readings,

Hourly Performance: (fill in only EDRP event hours) , , , , , , , , , , 0.2, 0.46, 0.5, 0.5, 0.5,

Prepared by, \_\_\_\_\_,

Date, \_\_\_\_\_,

Phone, \_\_\_\_\_,

Fax, \_\_\_\_\_,

E-mail, \_\_\_\_\_,