

Supplement to

Specifications for Electrical Installations

**Requirements for Parallel Generation Connected
to a National Grid Owned EPS**

Electric System Bulletin No. 756

September 2014, Version 2.2

(Supersedes all previous versions of ESB 756)



PREFACE

ESB 756-2014 references all requirements for parallel generation connected to National Grid facilities located in Upstate New York, Massachusetts, Rhode Island, and New Hampshire.

This supplement and its appendices are available from the Company's web site and may be obtained:

- From the Internet at <http://www.nationalgridus.com/electricalspecifications>,
- Or in printed form by contacting either of the Call Centers in Massachusetts or New York (see inside cover of ESB 750). However, printed copies are not document controlled, so for the latest authorized version please refer to the Company's website.

TABLE of CONTENTS

<u>SECTION</u>	<u>PAGE</u>
TABLE of CONTENTS	3
1.0 INTRODUCTION.....	3
1.1 PURPOSE.....	3
1.2 SCOPE.....	3
1.3 GENERAL RULES, AND CODES, STANDARDS AND REFERENCES	4
1.4 DEFINITIONS.....	5
2.0 REVISION HISTORY	6
LIST OF APPENDICES TO ESB 756.....	6
APPENDIX A: REQUIREMENTS FOR PARALLEL GENERATION CONNECTED TO NATIONAL GRID FACILITIES IN NEW YORK, VERSION 1.2.....	6
APPENDIX B: DISTRIBUTED GENERATION CONNECTED TO NATIONAL GRID DISTRIBUTION FACILITIES PER THE NEW YORK STANDARDIZED INTERCONNECTION REQUIREMENTS, VERSION 3.0	6
APPENDIX C: DISTRIBUTED GENERATION CONNECTED TO NATIONAL GRID DISTRIBUTION FACILITIES PER THE MASSACHUSETTS STANDARD FOR INTERCONNECTING DISTRIBUTED GENERATION, VERSION 2.0.....	6
APPENDIX D: DISTRIBUTED GENERATION CONNECTED TO NATIONAL GRID DISTRIBUTION FACILITIES PER THE RHODE ISLAND STANDARDS FOR CONNECTING DISTRIBUTED GENERATION, VERSION 2.0.....	6
APPENDIX E: REQUIREMENTS FOR PARALLEL GENERATION CONNECTED TO NATIONAL GRID FACILITIES IN NEW HAMPSHIRE, VERSION 1.1.....	6

1.0 INTRODUCTION

1.1 PURPOSE

The purpose of this National Grid Electric System Bulletin (ESB) is to:

1. Provide general requirements and recommendations for all generators connected in parallel with the electric power system (EPS) operated by National Grid (Company). Stand alone generators serving isolated load, which can never be connected in parallel with the Company EPS, are not subject to these requirements.
2. Ensure compliance with NERC Standard FAC-001-0 – Facility Connection Requirements, effective April 1, 2005. Along with all of the Company’s Electric System Bulletins, the most current version of ESB 756 is available electronically on its Niagara Mohawk Power Corp. d/b/a National Grid web page at: www.nationalgridus.com/electricalspecifications.
3. Ensure that the electrical reliability and security of the Company EPS and the larger power system grid is maintained following connection of the parallel generator to the utility supply.
4. Refer generator owners to the applicable FERC or state-specific tariff regulations pertaining to parallel generators.

1.2 SCOPE

1. This ESB addresses FERC-jurisdictional interconnections, where the generator wishes to interconnect to:
 - A transmission system owned by National Grid that is administratively controlled by a Regional ISO;

- A distribution or sub-transmission line owned by National Grid (which is presently interconnected to a third party energy supplier or generating facility selling power into the wholesale market) for the purpose of selling power into the wholesale market.
2. This ESB also addresses state-specific requirements pertaining to parallel generators. These are contained in individual appendices at the end of this document.

1.3 GENERAL RULES, AND CODES, STANDARDS AND REFERENCES

1. All parallel generator installations require an interconnection study, done at customer expense, to determine site-specific requirements (i.e. supply voltage, service arrangement, location, and generation intent). Generation intent, in this context, refers to its end use being either: (1) total generator output energy for internal use, i.e. peak shaving, (2) sale, or (3) a combination.
2. For electrical specifications not covered by this document, the Customer shall refer to the Company's other Electric System Bulletins: www.nationalgridus.com/electricalspecifications.
3. Load customers (end-user facilities) wishing to connect to the Company's transmission supply system should consult the National Grid ESB 750 Series for Upstate New York, Massachusetts, New Hampshire and Rhode Island. In addition, consult the Company for any questions not addressed by those documents.
4. Those wishing to establish "transmission facility interconnections" with National Grid's transmission supply system should consult the Company's Transmission Planning Department.
5. The Generator-owner's facility shall conform to the latest revision of all local, state and federal codes and national standards that apply; individual state Independent System Operator; Northeast Power Coordinating Council (NPCC), and North American Electric Reliability Council (NERC), Federal Energy Regulatory Commission (FERC), or successor organizations associated with the operation of such systems or entities.]
6. The Generator-owner's facility shall also conform to any applicable requirements of state public utility regulatory commissions and any local, state, federal and/or other agencies from which a review, approval, or a permit is required.
7. These requirements govern the operation of generation in parallel with the Company EPS. They concern only those points in which the Generator-owner and the Company have a mutual interest to ensure safety to Company employees and the public and satisfactory operation and compatibility with the electrical supply to others served by the Company EPS.
8. Regarding coordinated joint studies of new facilities and their impacts on the Company's interconnected transmission systems, the NY or NE ISO shall coordinate the conduct of any studies required to determine the impact of the Interconnection Request on Affected Systems with Affected System operators and, if possible, include those results (if available) in its applicable interconnection study within the time frame specified in these procedures. The regional ISO will include such Affected System operators in all meetings held with the Interconnection Customer as required. Notification of new or modified facilities to those parties responsible for the reliability of the interconnected transmission systems will occur as soon as feasible.
9. The voltage level, and MW and MVAR capacity or demand at the point of connection shall be addressed in a System Impact Study, which shall:
 - a. Consist of a short circuit analysis; a stability analysis; a power flow analysis; voltage drop and flicker studies; protection and set point coordination studies; and grounding reviews, as necessary.
 - b. State the assumptions upon which it is based, state the results of the analyses, and provide the requirement or potential impediments to providing the requested interconnection service, including a preliminary indication of the cost and length of time

- that would be necessary to correct any problems identified in those analyses and implement the interconnection.
- c. Provide a list of facilities that are required as a result of the Interconnection Request and non-binding good faith estimates of cost responsibility and time to construct.
10. Distribution System impact studies shall incorporate a distribution load flow study, an analysis of equipment interrupting ratings, protection coordination study, voltage drop and flicker studies, protection and set point coordination studies, grounding reviews, and the impact on electric system operation, as necessary.
11. Maintenance coordination and operational issues such as abnormal frequency and voltages shall be addressed by the regional ISO.
12. Inspection requirements for existing or new facilities, and communications and procedures during normal and emergency operating conditions are addressed in ESB 755, "O&M Requirements".
13. Any subsequent sale of generation ownership, which separates it from the remainder of a Customer's facility, requires the new Generator-owner to establish a separate interconnection for the generation.
14. Applicable national standards may include:
- IEEE 519 "Recommended Practices and Requirements for Harmonic Control in Electrical Power Systems"
 - IEEE 929 "IEEE Recommended Practice for Utility Interface of Photovoltaic (PV) Systems"
 - IEEE 1094 "IEEE Recommended Practice for the Electrical Design and Operation of Windfarm Generating Stations"
 - IEEE 1547 "Standard for Interconnecting Distributed Resources with Electric Power Systems"
 - NFPA 850 "Recommended Practice for Fire Protection for Electrical Generating Plants and High Voltage Direct Current Converter Stations"

1.4 DEFINITIONS

Company is National Grid

Company EPS refers to the electric power system owned, controlled, or operated by the Company used to provide transmission or distribution services to its customers.

FERC is Federal Energy Regulatory Commission.

Generator interface point is the point of electrical connection of the parallel generator to the premise wiring.

Generator-owner refers to any Non-Utility Generator even though they may also actually take electric service from the Company.

Interconnection Facility refers to those facilities necessary to affect the transfer of electricity from the parallel generator at the service point into the Company EPS.

Interconnection Point is where the interconnection facility connects to the Company EPS.

Interconnection System is the collection of all interconnection equipment and functions, taken as a group, used to interconnect a DR unit(s) to the Company EPS.

Islanding is generation serving utility load (or lines) without a synchronizing utility source connected.

ISO is Independent System Operator

ISO secured transmission system refers to delivery voltage systems as defined by the NPCC and controlled by a Regional ISO.

Isolation is where separation of electrical points of contact where interconnection may occur is at least 100 feet apart.

NERC is North American Electric Reliability Council.

NPCC is Northeast Power Coordinating Council

Parallel generator is defined as generation connected to a bus common with the Company EPS.

Production Facility refers to the generator owners' (producers') parallel generator facilities. It shall include all facilities and equipment up to and including the Production Facility's high voltage side generator transformer disconnect or switches.

Wholesale Delivery Point shall mean the point on the Company EPS where the interconnecting customer makes capacity and energy available, as indicated in the interconnection agreement.

2.0 REVISION HISTORY

<u>Version</u>	<u>Date</u>	<u>Description of Revision</u>
1.0	06/01/07	Initial version of new document superseding all previous revisions of ESB 756.
1.1	09/06/11	September 2010 ESB 750 Series Errata changes.
2.0	05/11/12	Revised ESB 756 Appendix C and added version numbers to appendices.
2.1	08/22/12	Revised ESB 756 Appendix D.
2.2	09/22/14	Editorial to ESB 756 Appendix A and Revised ESB 756 Appendix B.

LIST OF APPENDICES TO ESB 756

APPENDIX A: Requirements For Parallel Generation Connected to National Grid Facilities in New York, version 1.2

APPENDIX B: Distributed Generation Connected To National Grid Distribution Facilities Per The New York Standardized Interconnection Requirements, version 3.0

APPENDIX C: Distributed Generation Connected To National Grid Distribution Facilities Per The Massachusetts Standard for Interconnecting Distributed Generation, version 2.0

APPENDIX D: Distributed Generation Connected To National Grid Distribution Facilities Per The Rhode Island Standards for Connecting Distributed Generation, version 2.0

APPENDIX E: Requirements For Parallel Generation Connected to National Grid Facilities in New Hampshire, version 1.1

**Electric System Bulletin No. 756 Appendix A:
Requirements For Parallel Generation
Connected to National Grid Facilities in New York**

May 2007 version 1.2

ESB 756 Appendix A is part of the ESB 750 series

PREFACE

Electric System Bulletin 756 APPENDIX A provides requirements for interconnecting generation facilities, connected in parallel with the Company EPS, not covered by the New York Standard Interconnection Requirements (NYSIR) for 2MW and less aggregated parallel generation.

This is an appendix to ESB 756 and is available from the Company's web site and may be obtained:

- From the Internet at <http://www.nationalgridus.com/electricalspecifications>,
- Or in printed form by contacting either of the Call Centers in Massachusetts or New York (see inside cover of ESB 750). However, printed copies are not document controlled, so for the latest authorized version please refer to the Company's website.

TABLE of CONTENTS

<u>SECTION</u>	<u>PAGE</u>
TABLE of CONTENTS	3
1.0 GENERAL	4
1.1 PERMITTED CONNECTIONS	4
1.1.1 Phase Balance	4
1.2 ACCESS AND CONTACTS	5
1.3 DESIGN REQUIREMENTS	5
1.3.1 General Electrical Issues	5
1.3.2 Specific Electrical Issues	5
Figure No. 1	6
Figure No. 2	7
Figure No. 3	8
Figure No. 4	8
1.4 TYPES OF GENERATORS	8
1.4.1 Induction	8
1.4.2 Synchronous	9
1.4.3 Inverter Systems	9
1.5 LIMITATIONS	9
1.5.1 All Generation	9
1.5.2 Special Situations	10
2.0 PROJECT MANAGEMENT	10
2.1 RESPONSIBILITIES	10
2.1.1 Generator-Owner	10
2.1.2 Required Interconnection Study for Projects less than 115kV	11
2.1.3 Required Interconnection Study for Projects 115kV or Greater	12
2.1.4 No Agreement for Power Sales	12
2.1.5 Purchase of Generator-owner's Power	12
2.1.6 Interconnection Agreement	12
2.2 COOPERATION	13
2.2.1 Overall Project	13
2.2.2 Notification and Initial Documentation	13
2.3 DEVELOPMENT OF AN INTERCONNECTION ARRANGEMENT	15
2.3.1 Initial	15
2.3.2 Project Scheduling	15
2.3.3 Generation Scheduling	15
2.4 COMPLIANCE	15
3.0 SERVICE INSTALLATION	16
3.1 SERVICE EQUIPMENT	16
3.2 GROUNDING	16
3.3 METERING	16
3.3.1 Metering Location and Arrangement	16
3.3.2 Billing and Credit Metering	16
3.3.3 Non Residential On-Site Generation	17
3.3.4 Remote Acquisition of Meter Data	17
4.0 PLANT REQUIREMENTS	17
4.1 TELEMETERING	17
4.1.1 Telemetry Criteria	17
4.1.2 Telemetry Specifications	17
4.2 TELECOMMUNICATIONS	18
4.2.1 Installation	18

TABLE of CONTENTS

<u>SECTION</u>	<u>PAGE</u>
4.2.2 Specifications	19
4.3 POWER QUALITY.....	19
4.4 PERFORMANCE/DESIGN	19
4.4.1 Generator Criteria.....	19
4.4.2 Step-up Transformer Specification.....	21
4.5 PLANT PROTECTION.....	21
4.5.1 Plant Protection Criteria	21
4.5.2 Automatic Switching and Protective Devices	22
4.5.3 Relay Settings and Testing	25
5.0 OPERATING	26
5.1 MANUAL DISCONNECT SWITCH	26
5.2 DISCONNECTION BY THE COMPANY	26
5.3 OTHER	26
6.0 REVISION HISTORY	27

1.0 GENERAL

1.1 Permitted Connections

Certain interconnections are eliminated by the Company on the basis of the available systems without resort to the study of a specific instance. The Company shall determine the suitability of a given generator connection and its interconnection voltage.

Small parallel generation installations on distribution secondary network systems require study to ensure the electric source does not degrade the reliability, power quality, safety, or operation of the network system.

The Company will allow connection of parallel generation to spot networks under the following conditions:

1. When the aggregate parallel generation installed on a spot network does not exceed 5% of the spot network's maximum load; or,
2. If all of the following conditions are met:
 - Network protectors shall not be used to separate, switch, serve as breaker failure backup or in any manner isolate a network or network primary feeder to which the parallel generator is connected from the remainder of the Company EPS, unless the protectors are rated and tested per applicable standards for such an application.
 - Any parallel generator installation connected to a spot network shall not cause operation or prevent reclosing of any network protectors installed on the spot network. This coordination shall be accomplished without requiring any changes to prevailing network protector clearing time practices of the Company.
 - Connection of the parallel generator to the Company EPS is only permitted if the spot network bus is already energized by more than 50% of the installed network protectors.
 - The parallel generator output shall not cause any cycling of network protectors.
 - The network equipment loading and fault interrupting capacity shall not be exceeded with the addition of the parallel generator.

1.1.1 Phase Balance

The Generator-owner's facility shall maintain equal current in each phase conductor at the service point. Voltage unbalance resulting from unbalanced currents shall not

exceed 2 % or shall not cause objectionable effects upon or interference with the operation of the Company EPS and service to others. This criterion shall be met with and without generation.

1.2 Access and Contacts

1. Authorized Company employees, equipment, and vehicles shall have access to the Generator-owner facilities and Company's metering equipment at any time without delay.
2. The Generator-owner shall provide information identifying their contact person(s), addresses and their associated telephone number(s) to the Company.
3. Changes to phone numbers, points of contact, etc., shall be communicated in advance of the actual change, the effective date of change shall be provided as well.
4. The Company will provide the Generator-owner with phone numbers for the appropriate Company contact(s). (Customer Service Center for less than 15kV and the division Regional Control Center for greater than 15kV interconnections.)

1.3 Design Requirements

1.3.1 General Electrical Issues

1. The interconnection of all parallel generators requires safeguards for synchronization and back-feed situations. And, from the electric system perspective, the challenges posed by any given parallel generator connection do not diminish significantly with reduction in generator size. For this reason, each specific connection must be studied with respect to its size, its type, and the nature of the electric system at the interconnection point.
2. All parallel generation shall be designed to ensure:
 - Capability to synchronize with the Company EPS,
 - Capability to separate from the Company EPS upon loss of Company source, and
 - All energy supplied to the Company's electrical system shall meet the Company's power quality and transmission system operator requirements.
3. The Generator-owner shall be responsible for on-going compliance to regulatory, code, and system design and operating changes pertaining to their installation. This work will be performed at the cost of the Generator-owner. The Company requires all electrical and physical design documents and submittals in this and related Company bulletins relative to interconnections above 600 volts to be prepared and sealed by a single State-licensed Professional Engineer in the state where the installation is made, who is retained by the Generator-owner for that purpose.

1.3.2 Specific Electrical Issues

The Company will determine the interconnect voltage and method of interconnection with the system by specifically considering items R2.1.1 through R2.1.16 of NERC Standard FAC-001-0, as addressed in various portions of this ESB 756 and the Company's other published ESB's.

In general:

1. The preferred interconnection at 230kV and 345kV is a radial line(s) to ISO-secured transmission system station(s). Refer to Figures 1 through 4 for typical arrangements.
2. The preferred interconnection at 23kV up to 115kV is a radial line(s) to a station. Other interconnection alternatives may require installation of a Company three breaker station. Refer to Figures 1 through 4 for typical arrangements.

3. Company transmission system required to accommodate the generation interconnection shall be designed and installed to Company standards and practices, under the review and approval of the Company.
4. Regardless of interconnection voltage, protection schemes and connection arrangements shall be designed to prevent islanding of the generation with a portion of the Company's supply to other customers.
5. The Company reserves the right to review and approve the ratings and parameters of major electrical equipment supplied by the Generator-owner, such as, but not limited to: generator step-up (GSU) transformers, interrupting devices, relays, and the generator with its associated systems.
6. The Generator-owner is solely responsible for the protection of their plant equipment. The Generator-owner is required to provide electrical equipment and relays with ranges and ratings that will allow proper Generator-owner relay system coordination with Company relay systems. Coordination margins and parameters will be determined by the Company.
7. The Generator-owner is responsible for the coordination of any Generator-owner applied over and under frequency or over and under voltage generator tripping with Company specified requirements. The generator is expected to remain on line and fully operational following a system excursion within specified parameters. The correct performance of the generator frequency protection relays is critical to system security. Consequently each Generator-owner will be required to both recalibrate their frequency protection and provide the Company this relay performance documentation.

Figure No. 1

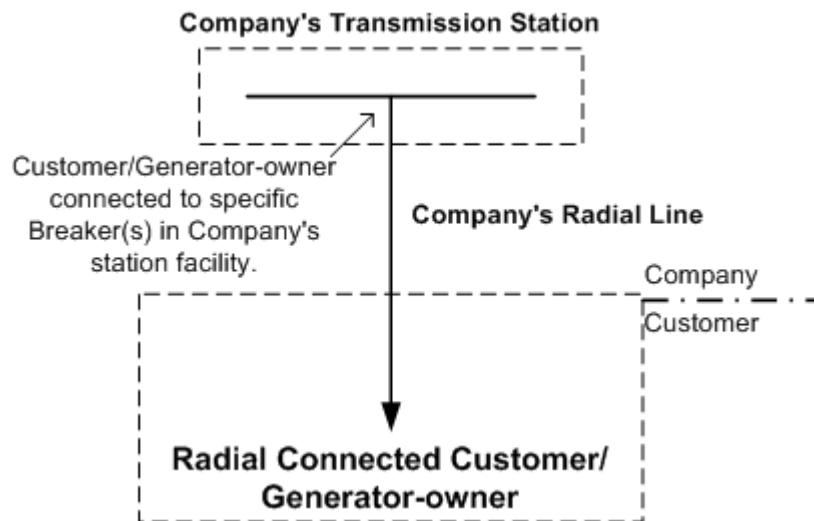

Figure No. 2

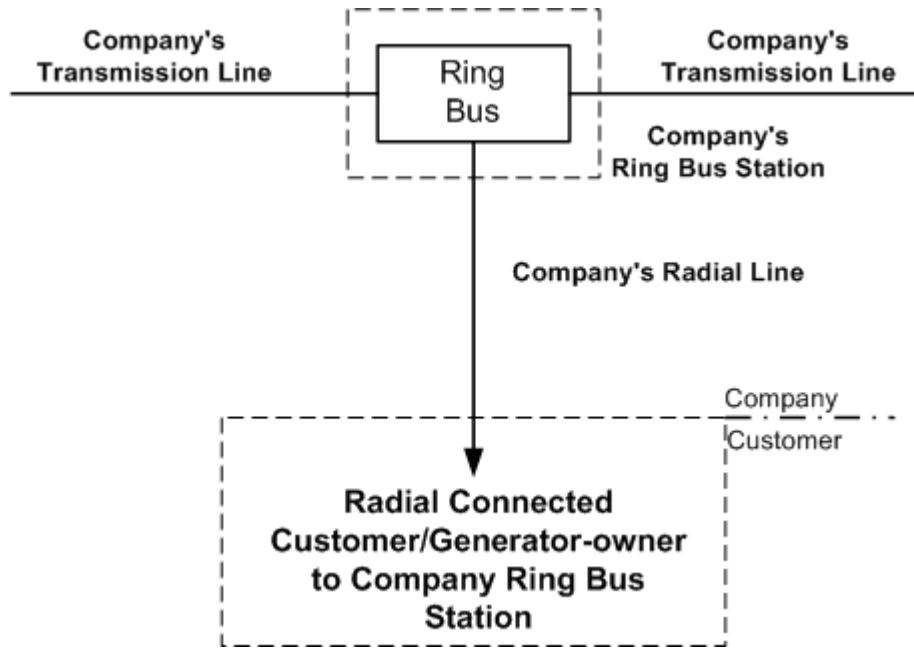

Figure No. 3

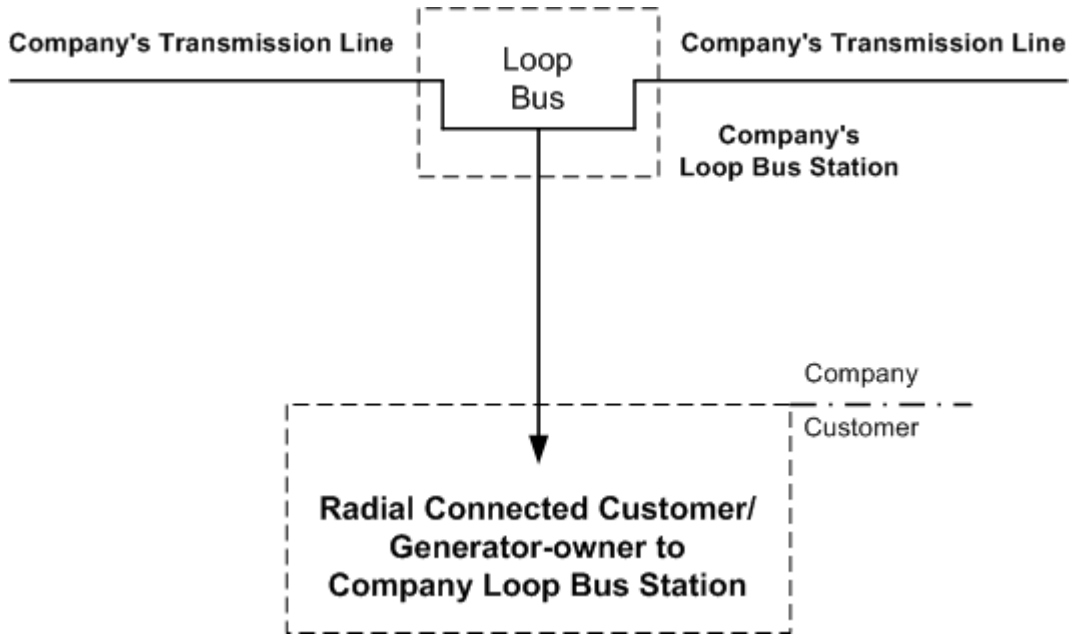
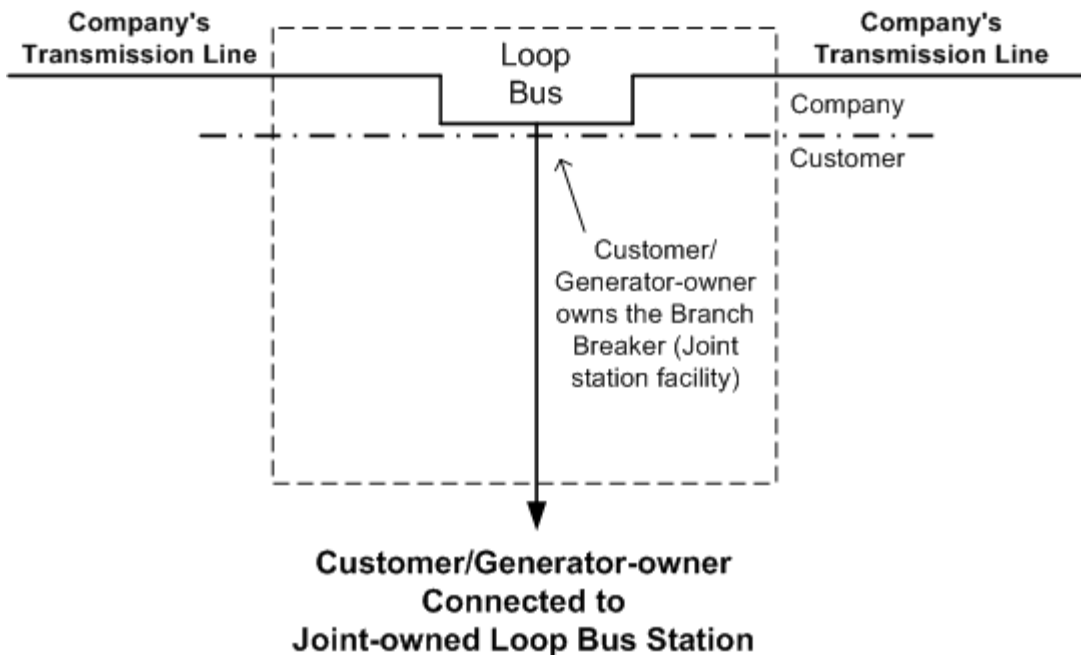

Figure No. 4



1.4 Types of Generators

1.4.1 Induction

1. Reactive power supply for induction generators poses difficult design problems, depending on the generator size.
2. Induction generation over 50kVA require capacitors to be installed by the Generator-owner. The installation of capacitors at or near an induction generator can cause it to become self-excited, if disconnected from the Company EPS. The additional expense for special protective equipment may favor the use synchronous machines.

3. Starting or rapid load fluctuations on induction generators can adversely impact the Company's system voltage. Corrective step-switched capacitors or other techniques may be necessary. These measures can, in turn, cause ferroresonance. Induction starting will be permitted only where inrush current and voltage will not exceed allowable limits.
4. Otherwise, protection for induction generation is similar to synchronous generation. Synchronizing relays may not be required, but a contact-making tachometer set at synchronous speed may be required.

1.4.2 Synchronous

For synchronous generators, sufficient generator reactive power capability shall be provided to withstand normal voltage changes on the Company EPS. The generator voltage-var schedule, voltage regulator, and transformer ratio settings will be jointly determined by the Company and the Generator-owner to ensure proper coordination of voltages and regulator action.

1.4.3 Inverter Systems

Direct current generators can only be paralleled with the Company EPS using a synchronous inverter. The design shall be such as to remove this synchronous inverter upon a utility system interruption. Proper harmonic filtering is necessary for inverter systems to minimize harmonic distortion from being introduced into the electric system.

1.5 Limitations

1.5.1 All Generation

1. The Company permits the operation of generating equipment in parallel with the Company EPS, whenever this can be done without adverse effects on the general public, Company equipment, or personnel, in accordance with all applicable laws and regulations. Certain protective devices (relays, circuit breakers, etc.), specified by the Company, shall be installed at any location where the Generator-owner desires to operate generation in parallel with the Company EPS. These devices promptly disconnect the Generator-owner's generating equipment from the Company EPS whenever faults or abnormal conditions occur.
2. The following are some of the issues considered before accepting generation:
 - Proximity to the Company's circuits.
 - Generation capacity and the load on the Company's circuits during light load conditions.
 - Review of voltage profiles and system thermal limitations provided by the Company's system electric studies.
 - System protection coordination with the proposed generation and prevention of the generator from "islanding."
 - Impact of prime mover.
 - Generator-owner's facility ratio of generation to light load.
3. From the above, the Company will determine the voltage, interrupting ratings, type of equipment and controls needed for proper protection coordination. The Company reserves the right to determine the Generator-owner's interconnection voltage.
4. The Company reserves the right to have the Generator-owner remove their generation from the EPS at any time upon the Company's request. Normally, such requests result from the need to facilitate maintenance, test, repair, and emergency restoration or safety concerns related to the Company EPS.

1.5.2 Special Situations

Under this bulletin, the Company restricts Generator-owner connection for the following situations.

1.5.2.1 Net Generation Output

The Company reserves the right to limit generation to its facilities operating to that level which will not compromise safety, reliability, or protection margins. Due to the many variable parameters involved, special requirements for any proposed net generation levels will be determined by the Company on a site specific basis.

1.5.2.2 Peak Shaving Generation

1. Arrangements for standby or supplemental energy needs are addressed by the Company's filed tariffs and shall be made prior to actual need to ensure its availability.
2. Peak shaving parallel generator installations shall not be allowed to supply any net generation into the Company EPS. The application of reverse power relays is an accepted method to accomplish the requirement. Where the Company is requested to supply demand pulse information (either analog or digital), its use is not intended for generator control.

2.0 PROJECT MANAGEMENT

2.1 Responsibilities

2.1.1 Generator-Owner

1. No generation, no matter its intent, shall be installed or operated in parallel with the Company EPS without prior notification to and approval by the Company.
2. This responsibility applies to an initial facility, as well as to subsequent additions and/or modifications of Generator-owner equipment or change of ownership through sale. The Generator-owner is responsible for modifying their system to comply with any future mandate of the Regional ISO; NPCC; and NERC or successor organizations including cost incurred.
3. If the Generator-owner makes significant changes in the design or scheduling of the project, then any previous information furnished by the Company to the Generator-owner shall be subject to review and possible change. Failure to communicate such changes to the Company may result in delay of service or termination of service by the Company.
4. The Generator-owner is responsible for performing all operating functions associated with their equipment and for maintaining all equipment under their ownership. The Generator-owner shall arrange to have trained personnel available for the proper and safe operation of their equipment.
5. The Generator-owner shall provide proper and continuous maintenance of all plant facilities; refer to NFPA 70B (and NFPA 73 where applicable) and other nationally recognized industry standards for guidance on electric equipment maintenance.
6. The Company will specify telecommunication services as required for the installation. See Exhibit 1 for data submittal in letterform to the Company.
7. For the RTU installation, the Generator-owner shall arrange through the Company to provide the necessary telecommunication service. As this process typically takes four months, the Generator Owner is responsible for submitting the information in Exhibit 1 in a timely fashion. The Company will not be liable for the results of any delays.
8. The Generator-owner's telephone number(s) shall allow for 24-hour per day contact of either a staffed control room or delegated operating agent.

9. The Generator-owner's backup service requirements from the Company EPS shall be requested using the prescribed forms in the Company's tariff.

10. Form G

1. Notice to the Company to install parallel generation shall be in the form of a completed Form G from the Company's tariff, PSC No. 220, signed by the Company and the Generator-owner. This form shall include:
 - 1) Complete generator data sheets,
 - 2) The generation's intended purpose, i.e. peak shaving or sale,
 - 3) Geographic location,
 - 4) Service point location i.e. circuit name and number, pole number, etc.,
 - 5) Contact information, name and telephone number of individual to be contacted regarding generator operation, and
 - 6) A provision stating that it is the responsibility of the Generator-owner to notify the Company, in writing, to obtain a new Form G whenever information changes.
2. A Letter of Commitment shall accompany the completed Form G and including:
 - 1) Result(s) of the Company's electric study,
 - 2) Written authorization from the Generator-owner for the Company to proceed with engineering and construction of the interconnection including initial payment.

11. Contributions

1. All costs incurred by the Company as a result of a Generator-owner's facility, over the life of that facility, shall be reimbursed to the Company by the Generator-owner. The Company will advise the Generator-owner concerning any charges and payment schedules required.
2. For net generation above 2MW, all costs incurred by the Company for supply system changes, metering upgrades, and telemetering circuit changes associated with the Generator-owner's installation shall be reimbursed to the Company by the Generator-owner. The Company will notify the Generator-owner when these situations arise along with their associated charges and execute terms and conditions for payment.

2.1.2 Required Interconnection Study for Projects less than 115kV

This study identifies the items of major cost to the interconnection. The scope of work is dependent upon the size and electrical location of the project. The study's primary function is to assess the impact the proposed project has upon the operation of the existing Electric Power System (EPS) and addresses the following principle areas:

2.1.2.1 Thermal margins

An assessment is made to ensure that the proposed project will not overload lines or impose operational constraints on the existing system.

2.1.2.2 Voltage performance

An assessment is made to ensure the proposed project can operate within voltage guidelines. For voltages 115kV and below, the guidelines are +5/-10% of nominal.

2.1.2.3 Stability

An assessment is made to ensure that local clearing times are such that unit stability is maintained and regional stability is not negatively impacted. Power system stabilizers shall be installed when such controls are required to dampen system oscillations.

2.1.2.4 Short Circuit Studies

A study is performed to ensure that circuit breaker duties remain within nameplate ratings with the addition of the project.

2.1.2.5 Protection

In this study phase an initial assessment is made to define required changes to local protection.

2.1.2.6 REGIONAL ISO/NPCC/NERC

Compliance with the planning standards of Regional ISO/NPCC/NERC will be required for ISO-controlled interconnections.

2.1.3 Required Interconnection Study for Projects 115kV or Greater

For 115kV or greater connections, the Generator-owner shall contact and obtain from the Regional ISO the requirements for an approved interconnection study. In this study phase an assessment will be made to ensure generation connected to the state jurisdictional secured transmission system complies with Regional ISO/NPCC/NERC or successor organization's planning standards in force at the time of energization of the Generator-owner's facilities.

2.1.4 No Agreement for Power Sales

Generator-owners who generate in parallel for the purpose of reducing their energy and demand utilization from the Company EPS (i.e. peak shaving generation) are not required to have a power purchase agreement with the Company. However, they still shall comply with the requirements of this bulletin and the Company's tariff, as determined by the Company. The Company on a case-by-case basis shall determine additional protective devices. The Generator-owner is required to complete all tariff forms relating to generators. The Company will advise the Generator-owner of any change of service class.

2.1.5 Purchase of Generator-owner's Power

1. Company's Tariff Service Option: The Company will advise the Generator-owner concerning a Service Class contract for any power purchased from the Generator-owner by the Company in accordance with the Company's state-applicable filed tariffs.
2. Direct Sale to the Regional ISO: The Generator-owner shall enter into an agreement with a Regional ISO for the sale of energy. This arrangement requires a separate agreement with the Company for the interconnection of the generating facility.

2.1.6 Interconnection Agreement

1. A signed Interconnection Agreement along with any other completed generator related tariff forms is required between a Generator-owner and the Company, and, if necessary, the ISO.
2. In general, the Interconnection Agreement will address the mutual acceptance of an interconnection study, which outlines any required electric system modifications and overall project capabilities, specifically:
 - 1) The amount of the generation, by unit and/or in total,
 - 2) The interconnection point voltage,
 - 3) The generation's intended purpose, i.e. peak shaving or sale,
 - 4) Its geographic and electrical location,
 - 5) Electrical arrangement and protection requirements,
 - 6) Electric study results of project generation impact,

- 7) Estimated cost, funding schedule, and timeline required to implement any needed Company EPS modifications to accept generation from the Generator-owner,
 - 8) Reimbursement to the Company for the operation and maintenance (O&M) to be performed by the Company on the interconnection facility,
 - 9) Additional agreements deemed necessary for project acceptance,
 - 10) Contact information, name and telephone number of individual to be contacted regarding Generator(s) operation, and
 - 11) Responsibility of the Generator-owner to notify the Company in writing whenever any change in the above information is contemplated, changes are subject to the approval of the Company.
3. A signed Interconnection Agreement is required between the Generator-owner and the Company before the Company will order major equipment or proceed with the project.

2.2 Cooperation

2.2.1 Overall Project

1. Any generating facility intending to operate with an interconnection to the Company EPS shall have the approval of the Company. Generator connections for the purpose of selling to the system require approval of the appropriate Regional Independent System Operator. This approval shall be in the form of a signed Interconnection Agreement. An Interconnection Agreement will not only identify changes to the existing EPS, but will specify Generator-owner plant performance requirements that may impact the specification major electrical components within the plant itself.
2. The Company will own, operate and maintain all electric lines and stations to the service point. There will be many occasions where the close cooperation between the Company and the Generator-owner during the design, license, right-of-way acquisition, and/or construction of Company facilities will be necessary. See the Company's **ESB 751** "General Requirements Above 600-volt Service" for more information.

2.2.2 Notification and Initial Documentation

1. The Generator-owner shall contact the Company regarding their desire to operate generation in parallel with the Company EPS and negotiate necessary agreement(s). In some cases, the Company will meet with the Generator-owner to mutually establish the arrangement and location of the proposed facilities.
2. Upon notification by a Generator-owner of their intention to operate generation in parallel with the Company EPS, in writing, the Generator-owner shall define their vision of the proposed project; providing the proposed site location, overall plant capabilities, the number, and size of equipment proposed, and proposed timing of project milestones. The Generator-owner shall develop and provide a functional single line diagram, complete with voltage and current interrupting ratings, type of equipment proposed, and all controls, complete with trip schemes, required by system protection parameters for proper protection and coordination with the EPS for Company acceptance. In addition, the specific project documentation indicated in this bulletin is also required. Three copies of each document, stamped by a State-registered professional engineer, are required unless noted otherwise.
3. Subsequent to this notification, the Company will review the project proposal and provide to the Generator-owner the estimated cost and time table for delivering the results of an electric study. The Company will respond with review comments on the concepts of the service arrangement, protective relaying, metering, and any special

requirements that may be needed for an electric study (see Sections 4 and 5). Data requirements for an interconnection study of projects are:

2.2.2.1 Study Phase:

Three copies of the following are necessary to begin the Company's study:

- (1) Exact physical location of the plant identified on USGS maps
- (2) Overall operational output (in MW) of the plant
- (3) Proposed single line diagram of the station showing the interconnection of major electrical components within the plant itself. This single line indicating proposed equipment ratings clearly needs to indicate:
 - (i) Number, individual ratings & type of units comprising the above rating
 - (ii) Number and Size of Generator step up transformers
 - (iii) General high voltage bus configuration and relay functions
- (4) General operational constraints such as the ability to run various combinations of units.
- (5) The following is a list of Electrical Data Requirements:
 - (i) Proposed generator step-up (GSU) transformer MVA ratings, impedances, tap settings and winding voltage ratings.
 - (ii) Proposed machine electrical parameters noted on Form G data sheets which include:
 - (iii) Machine nameplate data and reactive capability curves.
 - (iv) Impedances:
 - Direct axis and quadrature axis synchronous reactance;
 - Transient and subtransient components of positive sequence reactance data;
 - Negative sequence and zero sequence values.
 - (v) Time constants for both field open circuit and short circuit and armature short circuit quantities.
 - (vi) Turbine inertia constant.
 - (vii) Generator inertia constant: Appropriate IEEE system model including block diagram and parameter values for excitation and governor systems.
- (6) The proposed location and arrangement of Company metering equipment will be furnished by the Company and shall be included on the Generator-owner's drawings when submitted for acceptance.

2.2.2.2 Equipment Procurement Phase:

Either before an order is placed for electrical equipment or while in equipment manufacture scheduling prior to delivery, six (6) copies of equipment specifications, Protective Relay Device List, and a Bill of Material List shall be furnished to the Company for review and acceptance. Review and acceptance by the Company shall not be construed to be an approval of the Generator-owner's installation in regard to its overall safety or adequacy, but shall simply signify that the proposed arrangement and equipment meets the Company's interconnection requirements for connection to the Company EPS.

2.2.2.3 Final Design Start Phase:

The documents needed to be submitted to the Company prior to beginning the final design shall include a proposed time schedule to be mutually agreed upon, a plot plan and functional single line diagram showing protection, a protective relaying scheme and revenue metering. The relay types selected to provide these functions

must be acceptable to the Company. The Company will respond with the review comments on the concepts of protective relaying, metering and telemetry. This single-line diagram must be approved before final design is undertaken.

2.3 Development of an Interconnection Arrangement

2.3.1 Initial

Parallel generation will be accepted on the Company EPS at various voltage levels depending upon the generation installed and the capability of the circuit(s) to accept the electric power generated. The system will be studied in each case.

2.3.1.1 Funding:

Generator-owners are required to establish an account with the Company. This account shall hold sufficient funds to cover the Company's estimated cost of the development of an interconnection arrangement and, upon its acceptance, scheduled payments for project installation. Once sufficient funds and required data have been received, the Company will start work on the interconnection arrangement as directed by the ISO.

2.3.1.2 Presentation:

A meeting will be scheduled with the Generator-owner to formally convey, explain, and answer questions regarding its content. This meeting also provides an opportunity to update information, if necessary, for the installation phase of the project.

2.3.1.3 Acceptance:

The Generator-owner shall signify acceptance of the interconnection arrangement by providing a signed Interconnection Agreement and any necessary completed generator-related tariff forms and payment of any scheduled funding. The Company will not proceed with any work until these items are received.

2.3.2 Project Scheduling

Upon acceptance of the interconnection arrangement, the Generator-owner shall submit their project schedule. This schedule and subsequent changes will be mutually agreed upon.

2.3.3 Generation Scheduling

1. Generators selling into a Regional ISO market will submit bids as required by that ISO. Testing and outages will also be scheduled per the ISO requirements.
 - 1) In addition, for generation 10,000kVA and larger:
 - (1) To report the expected duration of a forced outage within 48 hours.
 - (2) To report non-scheduled maintenance or forced outages upon occurrence.
 - (3) To report 3-year planned maintenance outage requirements (expected duration, desired date and time) quarterly or as changed. The Generator-owner shall agree to an overall coordinated schedule to be provided by the Company.
 - 2) The Company, at its discretion, may extend the above requirements to installations of smaller size than indicated.
2. The Generator-owner shall be required to supply reactive power support when directed by the Company's transmission system operator or Regional ISO up to the agreed specified limit.

2.4 Compliance

The Company's rights to confirm and verify the compliance of the generator installation are described in ESB 750 or 752 as applicable and ESB 755. This includes energization and synchronization prerequisites, periodic checks and tests, and as-built documentation. In

addition, an executed interconnection agreement shall be submitted four weeks in advance of energization.

3.0 SERVICE INSTALLATION

3.1 Service Equipment

The Generator-owner shall provide service entrance equipment as a part of their installation. The Generator-owner's service equipment shall be rated, at a minimum, for the maximum fault current available from the Company EPS and their own contribution from the generator(s), motors, etc.

3.2 Grounding

As a minimum, the Generator-owner's generation equipment shall be grounded in accordance with the latest requirements of the National Electrical Code (NEC) or the National Electrical Safety Code (NESC) where the Generator-owner is under state utility regulation status. For specific installations, refer to the applicable sections of this document.

3.3 Metering

The Company reserves the right to determine that all metering schemes allow for the proper administration of all contracts and rates. Additional metering requirements are specified in the appropriate sections of this bulletin and the Company's various state tariffs, as filed.

3.3.1 Metering Location and Arrangement

1. Proposed location and arrangement of Company metering equipment will be furnished by the Company and included on the Generator-owner's drawings when submitted for approval. Where energy will be sold to the Company, a credit metering system will be installed.
2. Normally, for installations with credit metering the connection of the Company's PT metering transformers is on the generator side of the CTs. The instantaneous relative polarity of metering transformers is critical to proper operation. CTs are polarized such that the polarity dot or marking is on the Company side.

3.3.2 Billing and Credit Metering

1. The Company will specify the quantity, type, rating, connections, location and arrangement of all equipment required for the metering of the Generator-owner's service inclusive of the sale and/or purchase of energy as well as the monitoring of compliance with all applicable laws, regulations and contracts. Individual kWh meters either will be equipped with a detent to prevent reverse registration, or will be capable of bi-directional measurement.
2. A metering system will be installed to continuously record kilowatt-hours (kWh) on a time-differentiated basis. (To and From Company), and depending on magnitude of Generator-owner's load and/or generation, kilowatt demand (kW) (From Company), and kilovar demand (kVAR) (From Company). For those installations having a "Buy All-Sell All" purchase agreement contract in effect, additional kilowatt-hour (kWh) meters will also be installed on the output of the generator(s). Also, a recorder will be installed.
3. At the Generator-owner's request and cost, the Company will furnish equipment for demand pulse signals (analog or digital) at the point of the metering, which will represent the kW demand for operation of Generator-owner equipment. These signals are for information only and the Company shall not be liable for distorted or missing pulses. The Company will not provide time pulses.
4. Details of the installation requirements are covered in ESB 750 and the appropriate Electric System Bulletin Supplement.

3.3.3 Non Residential On-Site Generation

Non-Residential Customers with on-site generation (OSG) are subject to billing adjustments per the Company's Tariff. Additional metering will be installed at the Customer's expense in order to measure the appropriate adjustment.

3.3.4 Remote Acquisition of Meter Data

1. A dedicated, voice grade communication circuit is required to be installed at the Company's meter board. This circuit shall be furnished and maintained by the Generator-owner.
2. The Customer is responsible for arranging the installation and paying all costs associated with dedicated analog dial phone lines, or other types of automatic meter reading being employed by the Company, to both the OSG and billing meters.

4.0 PLANT REQUIREMENTS

4.1 Telemetry

4.1.1 Telemetry Criteria

1. The Company reserves the right to determine all telemetry and supervisory control schemes to allow reliable operation of the electric system and for the proper administration of all contracts.
2. For all installations 5,000kW or larger, telemetry of data, control and/or status of devices as specified by the Company is required. The Company also reserves the right to extend the need for telemetry to less than 5,000kW generators or where Merchant Plants desire this equipment for their Regional ISO requirements. This information is for the Company's Energy Management System (EMS) and will require the installation of Remote Terminal Unit (RTU) equipment in the Generator-owner's facilities.
3. The Company will furnish the telemetry RTU for the installation. The Company will specify the transducers, sensors or other components that the Generator-owner will purchase and acquire. Equipment furnished by the Company will remain Company property and will be maintained by the Company.

4.1.2 Telemetry Specifications

1. The RTU cabinet is typically 42" H x 30" W x 26" D shall be wall-mounted with the bottom edge 36" above the floor. A 5-foot clear working space shall be maintained in front of the mounting panel.
2. A dedicated 20A, 120VAC, single phase 60 hertz power circuit is required for the RTU cabinet. All conduit and wiring (minimum of No. 10 AWG copper) to the telemetry cabinet for this circuit shall enter the cabinet from the bottom. A three (3) foot length of all conductors shall be provided for final Company connection.
3. A dedicated 10A, 48VDC or 125VDC input is required to the Remote Terminal Unit (RTU) directly from the station battery.
4. The Generator-owner will be responsible for mounting this equipment in their installation, subject to Company approval. The Generator-owner will provide space, power and all input connections for this package, in the same area with the metering equipment (see ESB No. 752).
5. The following guidelines shall be adhered to:
 - 1) The RTU shall be located indoors within 15 feet of the billing meters to facilitate testing and calibration.
 - 2) The RTU shall be remote from heavy traffic areas, work areas and loading areas.

- 3) The RTU shall be remote from heat producing or high electrostatic or electromagnetic field producing equipment.
- 4) The RTU shall be remote from station batteries.
- 5) The analog inputs to the RTU shall be +1.0mA DC at rated input, +2ma DC maximum. The analog metered inputs required as metered at delivery point are as follows:
 - Net kW (+) - To the Company EPS
 - Net kW (-) - From the Company EPS
 - Net kVAR (+) - To the Company EPS
 - Net kVAR (-) - From the Company EPS
6. Where the Generator-owner's system includes generation and plant load, the metered values shall be the net sum of power from the Company's System, and the generation minus any internal plant load, which may be connected to the generator output circuits.
7. The Accumulator inputs to the RTU shall be:
 - Net kWh (+) - To the Company EPS
 - Net kWh (-) - From the Company EPS
8. The bi-directional metering equipment for telemetering shall be capable of providing instantaneous power and a pulse output that is proportional to integrated energy.
9. Additional inputs that normally will be required are:
 - Voltage (kV) - measured at the interconnection bus (service voltage)
 - Circuit breaker(s) control and/or status
 - Motor operated disconnect(s) status
 - Instantaneous value of frequency (Hz) - if so specified
 - Ring bus station voltage, current, active and reactive power at several locations.

Note: The Company will provide an EMS-RTU point list for inputs required at the Generator-owner facility.

4.2 Telecommunications

4.2.1 Installation

1. The telephone equipment shall be located as close to the RTU cabinet as feasible.
2. A voice telephone dedicated for Company use, furnished and maintained by the Generator-owner, is required in the Control House for the Company's Traveling Operators.
3. The Generator-owner shall incur all costs for the telecommunications services.

EXHIBIT 1: COMMUNICATIONS DATA

The following information is needed for the telephone requirements of the installation at the Generator-owner's site:

A. SITE INFORMATION

1. Location name.
2. Location address.
3. Location telephone number.
4. Geographic location for circuit termination (bldg., floor, and room).
5. Contact person's name, address and telephone number for engineering and access at the location.

6. As-built copy of substation ground grid and equipment grounding drawing. (Ground grid area - extent of ground potential rise zone of influence.) *
7. Results of ground grid resistance test. (Ground grid impedance in ohms.) *
8. Maximum line to ground fault including Generator-owner contribution. (Ground-return fault current, which produces ground potential rise {GPR} - steady state RMS volts).
9. Nominal System Voltage (kV)
10. X/R ratio at worst fault condition.
11. Ground potential rise (GPR) under worst case single phase to ground fault (steady state RMS volts) at the station and at the 300 volt zone of influence (ZOI) point.
12. Circuit required due date.

* For new installations, a ground grid analysis prepared by the Generator-owner's state-licensed design professional shall be provided.

B. BILLING INFORMATION

1. Billing contact for the invoicing of circuit.
2. Contact person's name, address and telephone number for billing purposes.

NOTE: The Generator-owner should forward the above information in writing to the Company as soon as possible. The Company will order telephone circuits. Circuit orders require approximately four months for installation.

4.2.2 Specifications

1. A plywood panel 3/4" x 48" x 48" is required for the telephone equipment. A four (4) foot clear working space shall be maintained in front of this panel. The Generator-owner will install terminal blocks directly adjacent to the telephone equipment for interconnection of the EMS-RTU.
2. A dedicated 20A, 120VAC, 60 hertz power circuit is required for the telephone equipment. The Generator-owner shall provide all conduit and wiring for the circuit and install one 20A, 120VAC, single phase convenience receptacle at the telephone equipment location.
3. Telecommunication's specifications are as follows:

Use	Circuit Class	Description
Voice	1 A	
Metering	1 A	Voice grade
RTU	3 A	Dedicated, voice grade data @ 2400bps, 4-wire ½ duplex, equipped with a passive loopback termination.
Protective Relaying	4 A	

4.3 Power Quality

Utility lines are subject to many natural and man-made hazards. The Company does not assume any responsibility for protection of generation or other electrical equipment. The generator-owner is fully responsible for protecting all of their equipment from damage due to faults and other disturbances, irrespective of the condition of the Company EPS. The Generator-owner shall not impact the Company's power quality characteristics.

4.4 Performance/Design

4.4.1 Generator Criteria

1. The Generator-owner shall provide generator controls to maintain proper voltage, frequency, and line current balance and permit synchronizing with the Company EPS. The generator facility's electrical output shall meet the performance requirements of the latest IEEE Standard 519 and ANSI C84.1 at the time it goes into service.

2. All generation projects operating in parallel with the Company EPS shall not adversely impact the existing system operation. Transmission lines shall remain within thermal ratings for normal and contingency conditions and the proposed project shall be capable of operation at full output over the range of system operating voltages. This range includes the normal nominal voltage range of 1.05p.u. to 0.95p.u. and the emergency range, which can extend to 0.90p.u. for short periods of time.
3. Projects utilizing synchronous and doubly-fed asynchronous machines are required to have excitation systems capable of automatic terminal voltage control. In general, long term operation with constant excitation (manual mode) is not acceptable. If power factor control is available it must be automatically disabled following a system disturbance to ensure sustained reactive support after an event. Power factor control and automatic voltage control schemes shall be mutually agreed between the Generator-owner and the Company. These requirements may typically lead to operational power factors at the Wholesale Delivery Point ranging between 0.9 lagging (vars to the power system) and 0.95 leading (vars from the power system). (Retail electric load customers with on-site generation shall provide reactive power support such that the retail load power factor is not degraded at the Retail Delivery Point.)
4. Projects utilizing induction machines will be required to utilize switched shunt compensation within their facility to minimize system voltage impacts over a wide range of the entire power output. Local power system requirements may lead to operational power factors at the Wholesale Delivery Point or Retail Delivery Point ranging between 0.9 lagging (vars to the power system) and unity. These facilities will also be required to meet the latest Regional ISO, NPCC, or local regional planning criteria. The overall project power factor requirements shall be mutually agreed between the Generator-owner and the Company.
5. Power plant auxiliary equipment shall not trip or stall for momentary under voltage or over voltage excursions anticipated by planning criteria.
6. Exhibit 2 summarizes plant under frequency and over frequency requirements parallel generation connected greater than 15kV by depicting a time frame just after the occurrence of a major system disturbance. Plant equipment is required to remain on line and fully operational throughout this recovery period.

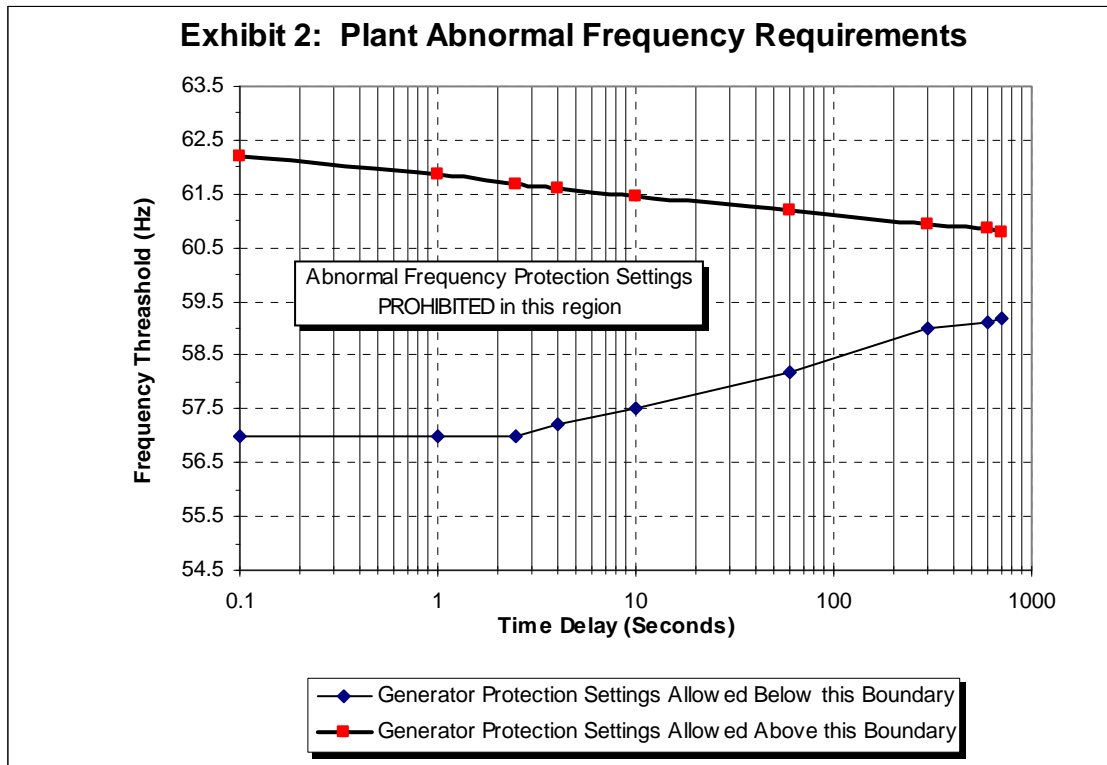
EXHIBIT 2: PLANT ABNORMAL FREQUENCY REQUIREMENTS FOR PARALLEL GENERATION INTERCONNECTED GREATER THAN 15 kV**4.4.2 Step-up Transformer Specification**

1. Generator step-up transformer connections and winding configurations shall be reviewed and approved by the Company before procurement by the Generator-owner. Acceptable equipment parameters are often determined by the location on the electrical system. The winding arrangement shall be such that the Company EPS remains effectively grounded.
2. Generator step-up transformer and auxiliary transformers shall have no-load tap settings and impedances coordinated with power system voltage control requirements and unit capabilities.

4.5 Plant Protection**4.5.1 Plant Protection Criteria**

1. Excitation equipment shall have an over excitation limiter coordinated with the thermal capability of the generator field winding. Longer over excitation time shall allow less overcurrent. The over excitation limiter shall also be coordinated with over excitation protection so that over excitation protection only operates for failure of the voltage regulator/limiter. Return to automatic voltage control after an over excitation event shall be automatic.
2. Under excitation limiters shall coordinate with generator capability (stator end-region heating) and power system stability limits. These settings shall also coordinate with loss of excitation protection.
3. Volts/hertz limiter equipment shall coordinate with volts/hertz protection.
4. Prime mover control (governors) shall operate freely to regulate frequency. Droop setting shall be in accordance with Regional ISO/NPCC/NERC standards. Prime movers operated with main valves or gates wide open shall control for over speed/over frequency. Boiler or nuclear reactor control and protection shall

- coordinate to meet the economic and safety requirements of the plant while maintaining the capability of the generator to aid in the control of system frequency during a power system disturbance.
5. Prime mover over speed controls shall be designed and adjusted to prevent boiler upsets and trips during partial load rejection characterized by abnormally high system frequency.
 6. Recording of performance during disturbances shall include generator terminal voltage and real and reactive power. Monitoring of other quantities such as field voltage and current, power system stability (PSS) output frequency or speed is best practice. These event recorders shall have adequate resolution and bandwidth to fully capture dynamic response of the generator.
 7. Protection shall allow temporary excursions in speed and system frequency anticipated by planning models without tripping. Such protection shall include over/under frequency relays as well as boiler safeguards. Under frequency protection shall be coordinated with the Regional ISO/NPCC/NERC under frequency load shedding program.
 8. Generator protection shall allow temporary voltage excursions anticipated by planning models without tripping. This protection shall include volts per hertz relays, generator auxiliary equipment under voltage relays, loss of excitation relays, backup distance relays, generator and transformer overcurrent relays, and out-of-step relays. These protection characteristics and settings shall be available to the Company upon request.
 9. For parallel generation interconnected greater than 15kV, frequency protection employed on all rotating apparatus shall allow the system time to recover by keeping units on-line during short term frequency excursions. With reference to Exhibit 2, a region is indicated during which the system frequency is recovering. Generation shall remain on line during this period. The lower bound is established by Regional ISO/NPCC/NERC criteria. The upper bound, although not yet part of these criteria, has been established for uniformity among projects taking into consideration equipment capabilities and the characteristics of the system response. All generation shall be capable of operating within this region.

4.5.2 Automatic Switching and Protective Devices

1. The generation facility shall employ the use of a properly applied interrupting device capable of automatic operation to interrupt the generation facility from the Company EPS. The device to be used shall be reviewed and approved by the Company before procurement by the Generator-owner. The Generator-owner shall provide protection as determined by the Company on a site specific basis.
2. The Company shall review and approve the protective relay devices provided by the Generator-owner for protection schemes required by the Company to protect its system. The use of utility grade relays and relay redundancy is a normal Company requirement. See Exhibit 3 for a reference list of most device nomenclature.
3. For interconnections on the Company's transmission system, frequency relays, where used, shall have ranges to meet the requirements of the Plant Abnormal Frequency Requirements Curve, see Exhibit 2. Voltage relays, where used, shall have ranges to meet the Company's transmission planning criteria of $\pm 5\%$ from nominal voltage and -10% for emergencies.
4. Protective relay devices provided by the Generator-owner for Company required protection schemes shall meet Company test device requirements.
5. Exclusion of Current Transformer Selector Switches: Meter selector switches shall not be connected into the secondary circuits of current transformers used with

protective relays specified by the Company. Metering shall not be connected in protective relay circuits.

6. It is Company practice to automatically reclose line circuit breakers, without employing synchronism check protection, within a few seconds after they have automatically been opened. The Generator-owner must take this fact into account in the design of their generator protection systems.
7. Following a generator disconnection as a result of Company source loss, the generation shall remain disconnected until such time as the Company source has recovered to Company acceptable voltage and frequency limits for a minimum of ten (10) minutes.
8. The following applies to parallel generation 2MW to 10MVA interconnected under **15kV** to the **Company EPS**:
 - 1) Interconnection systems with integrated relay protection shall meet the surge withstand requirements of IEEE 1547. Relays and control circuits associated with interconnection systems greater than 1000V shall meet the surge withstand requirements of IEEE C37.90.1.
 - 2) Neutral Stabilization - Where the Generator-owner is served from a Company four-wire multi-ground neutral distribution circuit, adequate grounding must be provided to ensure neutral stability during accidental isolation of the line from the main system. This may require an additional ground source. Adequate grounding can be provided either by the use of wye-delta main power transformer or by installing an appropriate grounding transformer. To limit the effects of such grounding on the Company's ground-relay sensitivity, the Company may require that the grounding impedance be limited to the highest value suitable for neutral stabilization.
 - 3) Frequency and voltage relays shall have ranges shown in the following table. The final time delay settings shall be approved by the Company.

DEVICE	PICKUP RANGE	TIME DELAY RANGE (sec)	DEFAULT TIME DELAY (sec)
Under Frequency (81U)	< 57.0 Hz	0.1 – 300.0	0.16
Under Frequency (81U)	< (59.8 – 57.0) Hz adjustable	0.1 – 300.0	0.16
Over Frequency (81O)	> 60.5 Hz	0.1 – 300.0	0.16
Under Voltage (27)	< 50% of Nominal	0.1 – 30.0	0.16
Under Voltage (27)	50% ≤ V < 88% of Nominal	0.1 – 30.0	2
Over Voltage (59)	110% < V < 120% of Nominal	0.1 – 30.0	1
Over Voltage (59I)	≥ 120% of Nominal	0.1 – 30.0	0.16

- 4) Following a generator disconnection as a result of Company source loss, the generation shall remain disconnected until such time as the Company source has recovered to acceptable voltage and frequency limits for a minimum of five (5) minutes.
- 5) Synchronization Requirements:
 - Synchronous interconnection with the Company EPS

The following parameters shall be within tolerances prior to closing the paralleling device:

Aggregate rating of parallel generator (kW)	Frequency Difference (Δ f, Hz)	Voltage Difference (Δ V, %)	Phase Angle Difference (Δ Φ, degrees)
0-500	0.3	10	20

Aggregate rating of parallel generator (kW)	Frequency Difference (Δf , Hz)	Voltage Difference (ΔV , %)	Phase Angle Difference ($\Delta \Phi$, degrees)
> 500 – 1,500	0.2	5	15
> 1,500 – 10,000	0.1	3	10

- Induction interconnection with the Company EPS

Self-excited induction generators shall meet the same requirements as synchronous machines.

For induction machines that are started as a motor, the Generator-owner shall provide the maximum starting inrush current that can be developed by the unit. This information shall be used in the Company's study to verify that the unit does not cause a voltage fluctuation greater than $\pm 5\%$ on the Company EPS or create visibly objectionable flicker as defined by IEEE 519. It is the Generator-owner's responsibility to maintain the unit within these voltage fluctuation and flicker limits at the interconnection point.

- Inverter Interconnection with the Company EPS

An inverter system that creates fundamental voltage prior before the paralleling device is closed shall meet the requirements of synchronous generators.

For all other inverter systems, the Generator-owner shall provide the maximum starting inrush current that can be developed by the unit. This information shall be used in the Company's study to verify that the unit does not cause a voltage fluctuation greater than $\pm 5\%$ on the Company's system or create visibly objectionable flicker as defined by IEEE 519. It is the Generator-owner's responsibility to maintain the unit within these voltage fluctuation and flicker limits at the interconnection point.

EXHIBIT 3: REFERENCE LIST OF STANDARD DEVICE NUMBERS

(SEE ANSI C 37.2-1987)

<u>Device Number</u>	<u>Function</u>
25	Synchronizing Device
27	Undervoltage Relay
32	Directional Power Relay
46	Negative Sequence Voltage
50	Instantaneous Overcurrent Relay
51	Phase Overcurrent Relay
51N	Neutral Overcurrent Relay
51V	Overcurrent Relay, voltage restraint
52	Breaker
52R	Recloser
59	Overvoltage Relay
59G	Neutral Voltage Relay
59N	Zero Sequence Voltage Relay
62	Time-delay Stopping or Opening Relay
64	Ground Protective Relay
81	Over and Under Frequency Relay
86	Locking - Out Relay
87	Differential Relay

(Refer to IEEE Standard 141 for typical electrical single-line diagram development.)

4.5.3 Relay Settings and Testing

1. Protection shall be provided by the Generator-owner such that abnormal conditions on the Company EPS will not cause damage to Generator-owner equipment. Protection also shall be provided by the Generator-owner such that abnormal conditions in the Generator-owner equipment will not cause equipment damage or abnormal conditions on the Company's system.
2. Company Required Relay Settings: The Company will review for acceptance the Generator-owner's proposed settings of those relays that the Company's System Protection Engineering Dept. designates as being required to satisfy the Company protection practices. Any relay setting issued by the Company shall not be changed or modified at any time without the prior written consent of the Company.
3. Company-designated Relay Calibration and Testing: Upon initial installation or modification, the Company will calibrate, test, and seal the devices for which Company relay settings have been issued, verify accuracy of associated circuit wiring and perform or at the Company's sole option, witness a functional test of the required devices, i.e., trip tests. At the Company's sole discretion, the calibration and test by a third party with Company approval of results may be an option. Refer to ESB 755 for additional details on the Company's policy regarding maintenance.
4. Generator-owner Supplied Relay Settings and Testing: The Generator-owner shall be responsible to specify the settings, calibrate, test, and maintain the balance of their equipment.
5. The NPCC has established criteria for periodically testing under frequency relays and reporting their performance used for load shedding critical to system security. Details of schedules, testing and reporting methods will be made available prior to synchronization.

5.0 OPERATING

5.1 Manual Disconnect Switch

The Generator-owner shall furnish and install an electrical load break disconnect switch accessible at all times to the Company. This disconnect shall be connected between the Generator-owner's facility and the connection point to the Company EPS. The visible disconnecting means may consist of a group-operated load air break switch and fuse, or group operated air break switch and circuit breaker. It shall be capable of being locked in the open position and have provisions for both Company and Generator-owner padlocks. This disconnect device shall be identified by a permanent sign as designated by the Company. Operation of this switch for any change in its status shall be immediately reported to the Company.

5.2 Disconnection by the Company

5.2.1 The Company reserves the right to open or order open the connection to the Generator-owner via circuit breaker, switches, etc., to isolate the Generator-owner's equipment without prior notice for the following reasons:

5.2.1.1 System emergency operations require such action. Emergencies include but are not limited to:

- Voltage excursions in excess of $\pm 5\%$ of nominal.
- Transmission system elements subjected to loading in excess of Long Time Emergency (LTE) ratings where disconnection alleviates the problem.
- Situations involving restoration of service.
- Excess generation on the Company EPS.

Note: When reduced generation output alleviates the problem, it may be ordered by the Company.

5.2.1.2 When the Company's periodic check of Generator-owner's equipment reveals a hazardous condition, a lack of necessary maintenance, or a lack of maintenance records for equipment necessary to protect the Company EPS.

5.2.1.3 When generating equipment interferes with other Generator-owners, other customers or with the operation of the Company's equipment. See Section 4.4.1 of this bulletin for Generation Criteria.

5.2.1.4 When required protective relaying is altered, inoperable, or missing.

5.2.1.5 When required special equipment necessary for operating control on the Company EPS is inoperable or missing.

5.2.2 Only the Company may permit the Generator-owner to energize a de-energized Company circuit for system restoration.

5.3 Other

1. In some instances, it may be required for Company operation of circuit protective devices and switches integral to the Company EPS within the Generator-owner's facility.
2. Sequence of events recorders shall be installed to log events such as limiter operation and protective trips (target logs) and generator performance during severe disturbances.
3. The Company or Regional ISO may, during emergency situations, implement voltage reduction as a load relief measure. The Generator-owner is responsible for any additional equipment necessary to remain on-line during such voltage reductions, refer to Section 4.0 of this bulletin.

6.0 REVISION HISTORY

<u>Version</u>	<u>Date</u>	<u>Description of Revision</u>
1.0	06/01/07	Initial version of new document superseding all previous revisions of ESB 756.
1.1	09/06/11	Permit study of DG on area networks in Section 1.1, no other technical changes, only formatting and general editing based on September 2010 ESB 750 Series Errata changes.
1.2	09/22/14	Added reference in Section 2.2.1.2 to ESB 751 released in June 2014. Editorial correction to Table header in Section 4.5.2.8.5.

Electric System Bulletin No. 756 Appendix B:

Distributed Generation Connected To National Grid Distribution Facilities Per The New York State Standardized Interconnection Requirements

September 2014 version 3.0

ESB 756 Appendix B is part of the ESB 750 series

TABLE of CONTENTS

SECTION	PAGE
TABLE of CONTENTS	2
1.0 Purpose	3
2.0 Scope	3
3.0 Customer-Generator Interface Procedures	4
3.1 APPLICATION PROCESS OVERVIEW	4
3.2 OBJECTIVES IN THE APPLICATION PROCESS	4
3.3 CONSIDERATIONS DURING THE APPLICATION PROCESS FOR DG INTERCONNECTIONS IN SECONDARY GRID AND SPOT NETWORK AREAS	6
3.4 INTERCONNECTION CHARGES.....	7
Table 3.4-1: DG Projects Not Eligible for the Expedited Process where no EPS upgrades are expected	7
Table 3.4-2: DG Projects Not Eligible for the Expedited Process	7
3.5 INTERCONNECTION PROCESS – COMPANY AND CUSTOMER FACILITIES	8
4.0 Overview of Potential Issues Related to Interconnection.....	8
ILLUSTRATION 4.6-1: TYPICAL DG INSTALLATION AREAS ON RADIAL DISTRIBUTION FEEDERS.....	9
TABLE 4.6-1: TYPICAL PLANNING LIMITS FOR DG CONNECTION TO RADIAL DISTRIBUTION FEEDER	9
5.0 General Design and Operating Requirements.....	11
5.1 APPLICABLE CODES, STANDARDS, AND GUIDELINES	11
5.2 DEFINITIONS	11
5.3 GENERAL CRITERIA	11
5.3.1 Single Phase	11
5.3.2 Three Phase.....	12
5.3.3 Phase Balance	12
5.3.4 Neutral Stabilization, Ground Fault, and Grounding.....	12
5.4 SERVICE EQUIPMENT AND REVENUE METERING.....	13
5.4.1 Service Equipment Requirements.....	13
5.4.2 Company Revenue Metering Requirements	13
5.5 TRANSFORMER	13
5.5.1 Purpose for DG System Interconnecting Transformer	13
5.5.2 Secondary Served Customer-Generators	13
5.5.3 Primary and Higher Voltage Served Customer-Generators	13
5.6 MANUAL GENERATOR DISCONNECT SWITCH	14
5.7 GENERATOR INTERRUPTING DEVICE REQUIREMENTS.....	15
5.7.1 General.....	15
5.7.2 Local Power Supply Requirements	15
5.8 PROTECTION AND PROTECTIVE EQUIPMENT REQUIREMENTS.....	15
5.8.1 Instrument Transformers for Protective Device Relays	15
5.8.2 Protective Relay Power Requirements.....	16
5.8.3 Protective Relay and Trip Circuit Hard-Wire Requirements	16
5.8.4 Type Tested Equipment	16
5.8.5 Non-Type Tested Equipment	16
5.8.6 Solar Photovoltaic (PV) Generation Requirements	17
5.8.7 Utility Grade Protective Device Settings and Verification	17
5.8.8 Anti-islanding.....	17
6.0 OPERATING	18
6.1 POWER FACTOR	18
6.2 POWER QUALITY MONITORING	18
6.2.1 Power Quality Compliance Verification	18
6.2.2 Power Quality Disturbance and Mitigation	18
6.3 ISOLATION	18
6.4 ENERGY MANAGEMENT SYSTEM-REMOTE TERMINAL UNIT (EMS-RTU).....	19

TABLE of CONTENTS

SECTION	PAGE
6.5 BALANCE OF CUSTOMER-GENERATOR EQUIPMENT	20
7.0 REVISION HISTORY	20
EXHIBITS ATTACHED.....	20
EXHIBIT 1: NIAGARA MOHAWK POWER CORP. ELECTRICITY TARIFF PSC No. 220, RULE 53	21
EXHIBIT 2: COMPANY REQUIREMENTS FOR DG SYSTEMS NOT ELIGIBLE FOR THE EXPEDITED PROCESS.....	22
EXHIBIT 3: REFERENCE MAPS OF NATIONAL GRID UPSTATE NY SECONDARY NETWORK EPS AREAS	23
EXHIBIT 4: DISTRIBUTION SECONDARY GRID AND SPOT NETWORK DESCRIPTION	24
EXHIBIT 5: RECOMMENDED GUIDELINES FOR RESIDENTIAL AND COMMERCIAL SINGLE-LINE DIAGRAM SUBMITTALS	25
FIGURE 1: SAMPLE DISTRIBUTED GENERATOR ONE-LINE DIAGRAM	26
FIGURE 2: TYPICAL SYMBOLOGY FOR ELECTRICAL DRAWINGS.....	27
EXHIBIT 6: RECOMMENDED GUIDELINES FOR FUNCTIONAL SINGLE-LINE DIAGRAM SUBMITTALS	28
FIGURE 3: SAMPLE FUNCTIONAL SINGLE-LINE DIAGRAM	29
FIGURE 4: TYPICAL 3V ₀ REQUIREMENTS FOR LOCAL EPS GROUND FAULT DETECTION	30
EXHIBIT 7: NET METERING COMPLIANCE VERIFICATION CHECKLIST	31

1.0 Purpose

1. Niagara Mohawk Power Corporation d/b/a National Grid (“National Grid” or the “Company”) strongly believes that promoting the installation of Distributed Generation (DG) systems, in accordance with the New York State Standardized Interconnection Requirements and Application Process for New Distributed Generators 2 MW or Less Connected in Parallel with Utility Distribution Systems (NY SIR or SIR), is sound public policy. This belief includes DG systems on network systems to the extent technically feasible.
2. The purpose of this Electric System Bulletin (ESB) is to assist a customer desiring to interconnect a DG system (Customer-Generator) to National Grid’s upstate NY distribution electric power system (Company’s Distribution EPS).
3. This ESB supplements ESB 750 and the NY SIR and provides general requirements, recommendations, and assistance to customers regarding DG systems, having an aggregate nameplate rating of 2 MW or less, connected in parallel to the Company’s Distribution EPS.

2.0 Scope

1. All generating interfacing equipment must be designed, installed, interconnected, tested, and operated in accordance with applicable government, industry, and Company standards. These requirements pertain to those types of parallel generation covered by the NY SIR connected to the Company’s Distribution EPS that are net metered generation sources (Net Metered Classes) or non-net metered generation sources with a nameplate rating of 2 MW or less. The SIR does not apply to DG systems larger than 2 MW.
2. These requirements are limited to only those points in which the Customer-Generator and the Company have a mutual interest to ensure safety to Company employees and the public and satisfactory operation and compatibility with the electrical supply to others served by the Company’s Distribution EPS. The provisions of this bulletin are applicable to Net Metered Classes and non-net metered generation sources covered under the NY SIR.
3. Technical requirements for parallel operated on-site generators (OSG) not covered by this document, such as DG systems larger than 2 MW and up to 20 MW (Over 2 MW Class), may be found in ESB 756 Appendix A.
4. These requirements may also be applied, at the discretion of the Company, to other methods used to generate electricity in parallel with the Company’s Distribution EPS not

ordinarily encountered or are not covered by the NYS Renewable Portfolio Standard (RPS), including but not limited to regenerative drives used in elevators and component power inverters used in exercise equipment and any other micro scale type energy recapture systems.

3.0 Customer-Generator Interface Procedures

3.1 Application Process Overview

This section outlines the process for a Customer-Generator to receive Company approval to interconnect DG systems to the Company's Distribution EPS. This process is intended for the following:

1. New DG systems with a nameplate rating of 2 MW or less (as aggregated on the customer side of the point of common coupling (PCC)), that are eligible under the NY SIR process and;
2. Review of any modifications affecting the Company's Distribution EPS and service connection interface at the PCC of existing Customer-Generator DG systems that: (i) have a nameplate rating of 2 MW or less as aggregated on the customer side of the PCC; (ii) are eligible under the SIR process; and (iii) have been interconnected to the Company's Distribution EPS where an existing interconnection agreement and/or power purchase agreement between the Customer-Generator and the Company is in place and;
3. New DG systems or modifications to existing DG systems over 2 MW and up to 20 MW as aggregated on the customer side of the PCC. Generation in this size range does not fall under the NY SIR. However, for larger Customer-Generator DG systems (i.e., over 2 MVA and up to 9 MVA connected to the Company's Distribution EPS), the Company will generally follow the approval process timeline set forth in the SIR as a guide for processing the customer's application made on Form G of National Grid's New York PSC No. 220 Electricity, i.e. [Electricity Tariff](#). In all other cases, the Company will, where possible, use a similar application and approval process as outlined in the SIR for types of DG systems. However, the time frames of the application process and level of requirements may be extended compared to those DG systems under the SIR guidelines due to the larger size of these generators and resulting increase in complexity of interconnection issues.

This application process and its requirements do not apply to generation equipment that will never be allowed to operate in parallel with the Company's Distribution EPS. For example, this process does not apply to emergency standby generators with break-before-make transfer switches and any other generation sources that operate independently of any connection to the Company's Distribution EPS and have no provision for such connection (even for a short period of time).

As stated above, this application process is mandated by the New York State Public Service Commission (PSC) for Customer-Generator's DG equipment up to 2 MW that will be connected to the Company's Distribution EPS on a full or part time basis; see the [NY SIR](#). These requirements are also contained in the Company's [Electricity Tariff](#), at Rule 53: Standardized Interconnection Requirements and Application Process for New Distributed Generators 2 MW or Less Connected in Parallel to Utility Distribution Systems.

3.2 Objectives in the Application Process

1. Parallel operation of a generator becomes a part of the Company's Distribution EPS whereby the Customer-Generator and the Company have a mutual interest in ensuring that the interconnection meets the required electrical reliability and security of the Company's Distribution EPS. This is necessary to ensure safety to the public and to Company employees and satisfactory operation and compatibility with the electrical supply to others. The steps and timing requirements of the application process are identified within the NY SIR. The time required to complete the application process, however, may depend on the characteristics of the DG system, the size class (as specified above), its intended operating modes, and the characteristics of the Company's Distribution EPS at the point of

interconnection (POI). It is the Company's objective that the application process should be completed in a timely manner that affords the lowest cost to the Customer-Generator while preserving the safety, reliability, power quality, and operational efficiency needs of the Company's Distribution EPS.

2. Additional site-specific requirements may be indicated once the supply voltage, service arrangement, location, and generation purpose is determined, where such purpose can be either:
 - peak shaving*,
 - net energy metering (and remote net metering), or
 - export energy with an agreement for sales** according to the Company's Electricity Tariff provisions.

** Peak shaving generation is customer-owned generation operated in parallel with the Company to reduce a customer's electrical demand. Unlike net metering, peak shaving generation is not permitted to flow into the utility supply system upstream of the billing meter and will require the installation of protection devices to limit such power export onto the Company's EPS. The Company's revenue metering is detented in this case to prevent reverse billing meter registration.*

*** An Agreement for Sales of Export Energy under a NY SIR application may be made per the Company's Electricity Tariff, Service Classification No. 6, and is a Power Purchase Agreement.*

3. For new electric service or modifications to the electric service connection to accommodate the customer's parallel generator, refer to the Company's latest revision of ESB No. 750, Specifications for Electrical Installations. The Customer-Generator will be responsible for any permitting and conformance to the latest revision of all local, state and federal codes and national standards that apply.
4. When considering a new or modified DG system interconnection arrangement, the following forms in the Company's Electricity Tariff are required to be submitted to the Company as applicable:
 - "Form "K" Appendix A Niagara Mohawk Power Corporation d/b/a National Grid New York State Standardized Contract for Interconnection of New Distributed Generation Units with Capacity of 2 MW or Less Connected in Parallel with Utility Distribution Systems."
 - For non-net metered applications, "General Information for Connection of On-Site Generators Application for Electric Standby Service Form "G"."
5. Any subsequent sale of an On-Site Generator (OSG) facility covered by the requirements of the NY SIR will require the new owner to establish a separate interconnection agreement (Form K) for the generation with the Company.
6. Refer to:
 - The steps to install DG systems in New York as specified in the NY SIR,
 - Attached **Exhibit 1** for the Company's Electricity Tariff, Rule 53 application process,
 - The Company's Distributed Generation Services **electronic mail address** for general inquiries: DistributedGenerationServices-NY@nationalgrid.com, and
 - The Company's Distributed Generation" web site at http://www.nationalgridus.com/niagaramohawk/home/energyeff/3_distributed.asp when making an application with the Company to interconnect a DG system with additional information and specific forms as follows:
 - Form K: http://www.nationalgridus.com/niagaramohawk/non_html/Form_K.pdf
 - Appendix B: http://www.nationalgridus.com/niagaramohawk/non_html/Appendix_B.pdf

- Appendix C: http://www.nationalgridus.com/niagaramohawk/non_html/Appendix_C.pdf
 - Form G: http://www.nationalgridus.com/niagaramohawk/non_html/Form_G.pdf
7. The application process and attendant services are offered by the Company on a non-discriminatory basis to any Customer-Generator. As part of the process, the Company may identify the need for detailed engineering studies (Coordinated Electric System Interconnection Review or CESIR), distribution system upgrades and additional protection requirements. As allowed by the PSC, the costs of the detailed study and upgrades are the responsibility of the Customer-Generator. If the Customer-Generator makes significant changes in the design or installation scheduling of their DG system, then any previous information furnished by the Company to the Customer-Generator is subject to review and possible change, which may cause a delay in service.
 8. The application process is structured to allow the Customer-Generator to review each the cost elements in advance so that the Customer-Generator may choose whether or not to continue moving forward with the process prior to committing to these costs. This avoids unnecessary expenditure of resources by either party and is for the benefit of both the Customer-Generator and the Company. Where a service upgrade is necessary and is above the base interconnection cost limits in the SIR, refer to the Company's [Electricity Tariff](#) and ESB 750 (http://www.nationalgridus.com/niagaramohawk/non_html/constr_esb750.pdf).
 9. The table at the following website summarizes the Company's application of the NY SIR net metering rules: https://www.nationalgridus.com/niagaramohawk/business/energyeff/4_net-mtrg.asp.

3.3 Considerations During the Application Process for DG Interconnections in Secondary Grid and Spot Network Areas

When applying for a DG system to be interconnected within the Company's secondary area network and secondary spot network EPS located in the downtown districts of Albany, Buffalo, Cortland, Glens Falls, Niagara Falls, Schenectady, Syracuse, Troy, Utica, or Watertown, DG system installations on distribution secondary network systems may require a study to be undertaken by the Company regardless of size, type or complexity to ensure that the DG system does not degrade the reliability, power quality, safety, or operation of the Company's network system. Therefore, customers in the downtown districts of Albany, Buffalo, Cortland, Glens Falls, Niagara Falls, Schenectady, Syracuse, Troy, Utica, or Watertown **should contact the Company at** DistributedGenerationServices-NY@nationalgrid.com to determine if the proposed location is served by a distribution secondary network system. This should be done while the DG system is still in the planning stage, and certainly before purchasing equipment or beginning installation. The Company will review the Customer-Generator's plans and discuss options with the customer. Refer to attached **Exhibit 3** for area maps locating the Company's secondary network service areas.

Unlike radial distribution systems that deliver power to each customer in a single path from source to load, underground secondary area network systems deliver power to each customer through a complex and integrated system of multiple transformers and underground cables that are connected and operate in parallel; refer to attached **Exhibit 4** for more information. Spot networks are similar to area networks except they serve a single premise. The connection of customer DG systems on networks is an evolving topic, which **(i)** poses some issues for the Company to maintain adequate voltage and worker safety and **(ii)** has the potential to cause the power flow on network feeders to shift (i.e., reverse) causing network protectors within the network grid to trip open. Therefore, to ensure network safety and reliability additional information will be required for the Company's engineering analysis such as:

- Customer's existing* or proposed electric demand profile showing minimum load during peak generation time,

- Customer-Generator's expected generation profile shown for a 24-hour period and typical 7-day duration based on nameplate generation rating, and
- Customer-Generator's complete electric service single-line diagram showing the configuration of the proposed generation and other metered tenants, if any, up to the service point supplied by the Company's secondary network EPS.

** In addition, the Company may need to install recording equipment at all metered electricity users to determine the total demand of the building's network service when obtaining the service connection's electric demand profile. The cost to the Customer-Generator will be according to the Company's electric customer load survey flat rate and charged in accordance with the terms of the Company's [Electricity Tariff](#) and NY SIR.*

3.4 Interconnection Charges

Customer-Generators shall be subject to charges for interconnection costs. To permit interconnected operations with a Customer-Generator, the Company may incur costs which are in excess of those it would have incurred had the customer taken firm service. These incremental costs, called interconnection costs, are directly related to the installation of those facilities the Company deems necessary for the interconnection of the DG system. They include initial engineering evaluations, purchase and installation of additional switching, transmission and distribution equipment at Company's facilities, additional safety provisions, engineering and administration. These costs shall be paid in full by the Customer-Generator prior to commencement of service in accordance with the Company's [Electricity Tariff](#), and the NY SIR. For typical Company interconnection cost items expected to support those proposed DG systems not eligible for the Expedited Process as defined in the NY SIR that will be defined in a CESIR, see the following two tables. Costs will be determined according to the Company's [Electricity Tariff](#) and the NY SIR.

Table 3.4-1: DG Projects Not Eligible for the Expedited Process where no EPS upgrades are expected

Item No.	Typical Company Support Activities Attributed to Customer-Generator's Project	Electricity Tariff Rule References
1	Engineering acceptance review of Customer-Generator's construction design submittals where the Company has mutual interest such as service connection facilities, meter mounting provisions, Company-designated protective devices and control schemes according to the Company's ESB 750 series.	24, 36, 37, 53
2	Revenue metering equipment changes/additions.	25, 36, 37, 53
3	Field audit of Customer-Generator's installation to accepted design.	24, 36, 37, 53
4	Field compliance verification - witness tests of Customer-Generator's protective devices coordinating with the Company's Distribution EPS.	24, 36, 37, 53
5	Project Management	53

Table 3.4-2: DG Projects Not Eligible for the Expedited Process

Item No.	Typical Company Support Activities Attributed to Customer-Generator's Project	Electricity Tariff Rule References
1	Distribution EPS upgrades (e.g., Current Limiting Fuses, Primary Conductors, Line Reclosers, Switches, Voltage Regulators, Capacitors, etc.) as a result of DG system impact.	15-18, 28, 36, 37, 53
2	Where Local EPS anti-islanding protection is required, DTT transmit addition to Distribution EPS substation feeder breaker (and/or Line Recloser) for DG system impact on distribution feeder.	28, 36, 37, 53
3	Where Company-provided Radio Communications can be applied, additions to support DTT equipment at Distribution EPS substation feeder breaker (and/or Line Recloser) for DG system impact on distribution feeder.	28, 36, 37, 53
4	Where Local EPS feeder selectivity may require prompt control measures for DG system impact on distribution feeder operations, EMS-RTU (status & control) addition at the DG system's facility.	28, 36, 37, 53
5	Service Connection modifications and additions for DG system impact on the Company's Distribution EPS.	19-23, 28, 36, 37, 53

Item No.	Typical Company Support Activities Attributed to Customer-Generator's Project	Electricity Tariff Rule References
6	Engineering acceptance review of Customer-Generator's construction design submittals where the Company has mutual interest such as service connection facilities, meter mounting provisions, Company-designated protective devices and control schemes (e.g., DTT receive package installation at DG system) according to the Company's ESB 750 series.	24, 28, 36, 37, 53
7	Revenue metering equipment changes/additions.	25, 28, 36, 37, 53
8	Field audit of Customer-Generator's installation to accepted design.	24, 28, 36, 37, 53
9	Field compliance verification - witness tests of Customer-Generator's protective devices coordinating with the Company's Distribution EPS.	24, 28, 36, 37, 53
10	Project Management	28, 53

3.5 Interconnection Process – Company and Customer Facilities

The process for installation of those facilities the Company deems necessary for interconnection of the DG system will be specified by the Company in response to the Customer-Generator's application. See **Exhibit 2** for Company Requirements for Projects Not Eligible for the Expedited Process.

4.0 Overview of Potential Issues Related to Interconnection

1. Customer generation connected to the distribution system can cause a variety of system impacts including steady state and transient voltage changes, harmonic distortion, and increased fault current levels. Parallel generation systems of 2 MW or less located individually on higher capacity feeders may not cause very serious impacts whereas those located on weaker circuits, in aggregation or in special cases (such as lightly loaded networks), can significantly impact the Company's Distribution EPS.
2. A CESIR in some cases is needed to identify the severity of system impacts and the upgrades needed to avoid problems on the Company's Distribution EPS. Typically, a CESIR will be performed by the Company to determine if the proposed generation on the circuit results in any relay coordination, fault current, and/or voltage regulation problems.
3. There is a wide range of potential issues associated with the interconnection of DG systems to the Company's Distribution EPS including, but not limited to:
 - Impact on step voltage regulation equipment
 - Increased fault duty on Company circuit breakers
 - Interference with the operation of protection systems
 - Harmonic distortion contributions
 - Voltage flicker
 - Ground fault overvoltages
 - Islanding
 - System restoration
 - Power system stability
 - System reinforcement
 - Metering
4. It is important to scrutinize the interconnection of customer's DG systems to the Company's Distribution EPS so that any negative impacts can be avoided and assure that the customer's DG system will have only a positive impact or, at a minimum, no degradation of EPS performance. It is the intent of any Company study in accordance with SIR requirements, when applicable, to avoid negative power system impacts by identifying the particular type of impact that will occur and determining the required equipment upgrades that can be installed to mitigate the issue(s).
5. Anywhere within the Company's service territory where customers plan to interconnect generation, they will be interfacing to one of two main types of distribution systems. These

will be either radial systems or network systems. The interface voltage levels will be either low voltage (less than 600 volts) or medium voltage (greater than 600 volts and less than 15,000 volts) depending on the location on the Company’s system and size of the generator.

6. In general, DG facilities connected to various locations on the radial distribution EPS are limited as listed in the below Table 4.6-1. This table provides an upper limit that represents the maximum possible DG capacity under ideal situations that can be installed on the Company’s Distribution EPS and assumes that there are no additional limitations on the Company’s Distribution EPS as indicated by site specific system studies (e.g., available short circuit current contributions, minimum network loading in light loading seasons, voltage regulator interactions, etc.). When a DG system (or aggregate DG system) on a feeder or local EPS of a feeder is above the limits in Table 4.6-1, these warrant further study by the Company to determine feasibility and remedial action.

Illustration 4.6-1: Typical DG Installation Areas on Radial Distribution Feeders

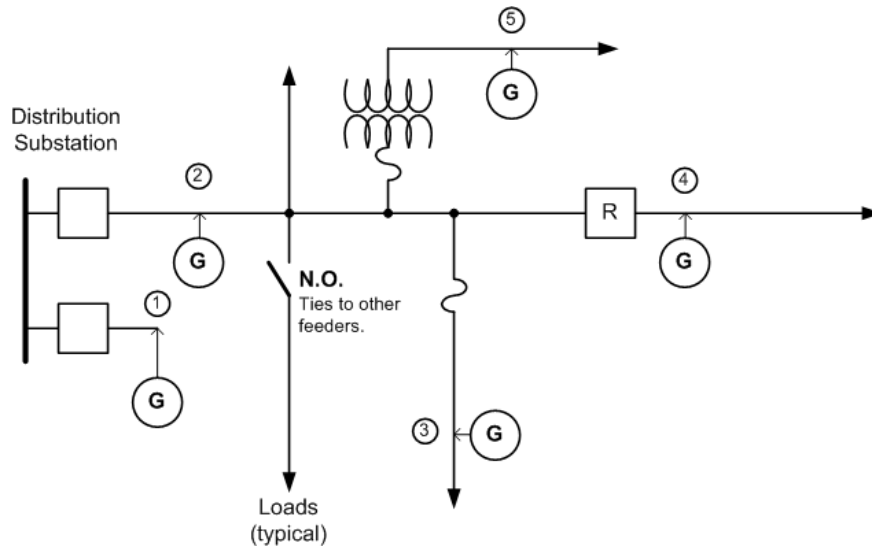

“O” - DG Interconnection Location Point on Feeder

1. Express (dedicated) radial feeder
2. Feeder Main
3. Feeder Branch protected by fuse
4. Sectionalized Feeder Main
5. Feeder Branch protected by fuse with ratio transformer

Table 4.6-1: Typical Planning Limits for DG Connection to Radial Distribution Feeder

Typical Gross Generation Capacity Limit (see notes below)		
DG Location on Feeder	3-phase Radial Distribution Voltage Class System	
	4 or 5 kV	15 kV
1. Express (dedicated) Radial Feeder	2.8 MVA	9.0 MVA
2. Feeder Main	750 kVA	2.5 MVA
3. Feeder Branch protected by Fuse	75 kVA	250 kVA
4. Sectionalized Feeder Main	100 kVA	300 kVA
5. Feeder Branch protected by Fuse with Ratio Transformer	50 kVA	150 kVA

Notes to Table 4.6-1:

- a. These generation capacities are on a per-generator basis on full nameplate ratings and at unity power factor. It should be noted, however, that the aggregate generation (sum of the total gross generation of all DG systems connected to a particular segment of the Company’s system) is considered for all points along the distribution feeder. The Company will evaluate each application before deciding on the maximum MVA allowed onto the National Grid system at a given point.

- b. *The above limits apply to synchronous and induction rotating generator machines. Large solar photovoltaic (PV) inverter-based systems (for instance, 500 kVA on 4 or 5 kV class systems or 3.0 MVA on 15 kV class systems) may begin to have greater affect on EPS voltage regulation due to the effects of cloud transients.*
- c. *On single-phase radial distribution systems, generator interconnections with aggregate generator nameplate ratings over 50 kVA may require three-phase service. These situations will be determined by the Company on a case-by-case basis.*
7. Connecting customer generation to the **low voltage secondary network systems** pose some issues for the Company as described in Section 3.3. The generation can cause the power flow on network feeders to shift (i.e., reverse) causing network protectors within the network system to trip open. Synchronous generators are not permitted to interconnect to the Company's secondary voltage network systems. Small induction and inverter-based generators are considered on the secondary voltage network systems on a case-by-case basis.
8. Connection of DG systems on the **spot networks** are only permitted if the secondary bus is energized by more than 50% of the number of installed network protectors as required by the current version of the Institute of Electrical and Electronics Engineers (IEEE) Std. 1547.
9. From Table 4.6-1, DG systems ranging in size from 750 kVA to 2.8 MVA at 4 or 5 kV class or from 2.5 MVA to 9.0 MVA at 15 kV class and installed on non-network systems are considered for connection to express radial distribution feeders due to potential negative power quality and reliability impact to other customers located on a normal distribution area EPS.
10. Because of the severe safety and potential equipment damage issues associated with feeding power into a de-energized distribution system, a major design consideration of any Customer-Generator's installation is that THE GENERATOR SHALL NOT ENERGIZE A DE-ENERGIZED COMPANY CIRCUIT. The protection system shall be designed with interlocks and proper protective functions to ensure that there is proper voltage, frequency and phase angle conditions between the Company's EPS before the DG system is permitted to parallel. Because of the potential interference with reclosing on radial and automatic sectionalizing feeders and/or restoration operations on the utility system, AUTOMATIC RECLOSING OF THE CUSTOMER-GENERATOR'S INTERTIE CIRCUIT BREAKER IS NOT PERMITTED. The only exceptions that allow a DG system to automatically reconnect are certain inverter-based generation systems as permitted by the NY SIR.
11. The Company's distribution substations are subject to fault duty limitations. Adding generation to the Company's Distribution EPS increases the amount of fault current imposed on the substations and equipment located on the feeder(s). Exceeding the fault duties of equipment and devices at the substation(s) and on the feeder(s) as a result of DG systems will not be permitted and alternate methods of interconnection shall be explored or the replacement of "overduty" equipment and devices with the appropriate ratings and of Company standard design where this limit has been reached (see also Section 5.3.4).
12. Multiple service facilities may be supplied to the customer from the Company's Distribution EPS. These service installations may be either dual primary switchgear or dual secondary transformers. To assure that the reliability and proper protection are maintained in these multiple service facilities, the Customer-Generator is not permitted to:
- Parallel secondary services from a common facility.
 - Parallel secondary facilities supplied from separate locations.
 - Exceed the ampacity rating of any service facility.
 - Create an unbalanced loading condition in excess of 2% voltage unbalance between phases of a service.

5.0 General Design and Operating Requirements

From the perspective of interconnection, there are three main types of Customer-Generator systems that interface to the EPS. These include:

- Induction Generators
- Static Power Converters (inverter-based)
- Synchronous Generators

Each type has its own specific characteristics regarding synchronization equipment, protective functions, starting practices, and electrical operating behavior. Whether the parallel generation is less than 2 MW and covered under the SIR guidelines or larger than 2 MW and covered under other requirements, there are specific common interface requirements that will always apply. There may also be additional specific requirements that may be identified as part of any CESIR that is performed for a specific DG system location.

5.1 Applicable Codes, Standards, and Guidelines

1. The customer's DG system shall conform to the latest revision of all local, state and federal codes and national standards that apply.
2. The Customer's Generator's DG system shall also conform to any applicable requirements of the PSC and any local, state, federal and/or other agencies from which a review, approval, or a permit is required.
3. The Customer-Generator shall comply with the appropriate Company ESB or Electricity Tariff requirements, which cover details for the customer's electric service installation.

These include:

- **ESB 750** - Specifications for Electrical Installations
- **ESB 751** - General Requirements Above 600-volt Service
- **ESB 753** - Primary Meter Pole
- **ESB 754** - Outdoor Pad Mounted or Vault Enclosed Single and Three Phase Transformer
- **ESB 758** - Primary Service to Metal Enclosed Gear
- **PSC 220** - Niagara Mohawk Power Corporation's Electricity Rate Tariff
- **PSC 220, Rule 53** - Standard Interconnection Requirements for OSG's 2 MW or Less Connected in Parallel with Utility Distribution Systems

Refer to **Exhibits 5** and **6** and **Figures 1** through **4** for information when submitting single-line diagrams to the Company's electronic mail address at DistributedGenerationServices-NY@nationalgrid.com).

5.2 Definitions

See Rule 53 of the [Electricity Tariff](#) and the NY SIR for definitions of special terms.

5.3 General Criteria

The interconnection of all DG systems in parallel with the Company's EPS requires safeguards for synchronization and back feed situations in accordance with the NY SIR. Each specific connection must be studied with respect to size, type, and the nature of the EPS at the interconnection point. Only the results of a specific study can indicate the suitability of a given DG system connection to the Company's EPS and its possible economic viability. See **Rule 53** of the [Electricity Tariff](#) and the [NY SIR](#) for detailed requirements.

5.3.1 Single Phase

Single phase DG system connections to the Company's Distribution EPS circuits under 600 volts present power quality and phase balance challenges. Single phase connections shall have these minimum characteristics:

- Nameplate rating of a single generator or group of generators equal to or less than 50 kVA unless otherwise specified by the Company on a case-by-case basis.

- Configured as a three-wire, line-to-line with neutral, or line-to-neutral with adequate load balance.
- A dedicated service lateral with a dedicated transformer, when required by the Company.

5.3.2 Three Phase

Other than permissible single phase connections in Section 5.3.1, three phase connections are required. The aggregated nameplate rating of all DG systems operating in parallel with the Company's Distribution EPS on the premise shall not exceed 2 MW covered by the NY SIR. For more than 2 MW, refer to ESB 756 Appendix A.

5.3.3 Phase Balance

The Customer's DG system shall permit equal current in each phase conductor at the service point. Voltage unbalance resulting from unbalanced currents shall not exceed 2% and shall not cause objectionable effects upon or interfere with the operation of the Company's facilities and service to others. This criterion shall be met with and without generation.

5.3.4 Neutral Stabilization, Ground Fault, and Grounding

1. Where the Customer-Generator is served from a Company four-wire multi-ground neutral distribution circuit, an effectively grounded system with respect to the Company's EPS must be provided to ensure neutral stability and avoid distribution circuit over voltage during accidental isolation of the Company's area EPS from the main Company system. This may require an additional ground source. Adequate grounding can be provided either by the use of wye grounded-delta main power transformer (see Section 5.5) or by installing an appropriate grounding transformer.
2. The effects of such grounding on the Company's ground-relay sensitivity shall be limited. The Company requires ground protection on any system that can be a generation source and to protect transformers that can be paralleled and supplied from two sources. When generator tripping is needed to sense ground faults on the Company's Distribution EPS:
 - The winding arrangement of the Customer's generation facility transformer shall be such that the Company's system remains effectively grounded (see Section 5.5.3).
 - The Company may require that grounding impedance be limited to the highest value suitable for neutral stabilization or to limit generator ground fault contributions. Contribution to the faults on the Company's four-wire distribution EPS can desensitize the relays upstream of the Customer-Generator's interconnection. Hence, it is required that the Customer-Generator provide a means to install a grounding reactor within their facility to limit the ground fault current to three times the generator rating and, where possible, to limit the rise of ground fault current at the point on the high voltage (primary) level nearest the proposed service point by no more than 10%. The grounding reactor shall not violate the effectively grounded system requirements. The size of the grounding reactor will be specified by the Company. If the 10% criteria is not met with the grounding reactor, other methods, upon Company acceptance may be required by the Customer-Generator to mitigate the increase in fault current.
 - If the Customer-Generator is permitted to interconnect through an un-grounded source, a "zero-sequence" voltage or "3V₀" scheme will be required on the primary side of the approved delta primary wound transformer (see Section 5.5.3) supplying the DG system. In cases where the Company's EPS is an ungrounded circuit, the 3V₀ scheme may be waived at the Company's discretion on a case by case basis. Refer to **Figure 4** for additional information.
3. As a minimum, the Customer-Generator's DG system equipment shall be grounded in accordance with the latest requirements of the National Electrical Code (NEC). For

specific installations, refer to the applicable sections of this document and the Company's ESB 750.

5.4 Service Equipment and Revenue Metering

5.4.1 Service Equipment Requirements

1. The Customer-Generator shall provide service entrance equipment as a part of their installation; see the Company's ESB 750. The Customer-Generator's service equipment shall be rated, at a minimum, for the maximum fault current available from the Company's Distribution EPS and their own contribution from the generator(s), motors, etc.
2. At the service entrance equipment, the Customer-Generator shall have a permanent directory plaque to indicate all electric sources and the Generator Disconnect location(s) on their premise according to the NEC.
3. For situations where a higher voltage service connection is required, refer to the Company's ESB 752, 753, or 758 as applicable.

5.4.2 Company Revenue Metering Requirements

1. The Company will specify the location and arrangement of all equipment required for the revenue metering of the Customer-Generator's service and DG system as well as the monitoring of compliance with all applicable laws, regulations, interconnection agreements, and power purchase agreements. Reference the Company's ESB 750, Section 7 for additional information and requirements. The NY SIR and Rule 53 of the [Electricity Tariff](#) describe qualifications for net metering. Where net metering does not apply, the Company's revenue metering will be detented* to prevent reverse billing meter registration. When applicable, credit metering will be installed if arrangements have been made for energy sales to the Company; see Service Classification No. 6 of the [Electricity Tariff](#).

* "Detented metering" is measuring and registering power flow in a single direction by either mechanical, or electronic, or programming means in a revenue meter.

2. The Company will determine the telecommunications requirements, if any, for the specific Customer-Generator's DG system installation for Company-owned revenue metering.

5.5 Transformer

5.5.1 Purpose for DG System Interconnecting Transformer

An interconnecting transformer at a DG system serves three purposes. First, it enables proper voltage matching between the generator and the utility connection. Second, it can act as a buffer to limit any current contribution from the DG system in the event of a short circuit on the electric system. Third, it can assist in ensuring effective grounding of the utility circuit when the DG system is exporting power.

5.5.2 Secondary Served Customer-Generators

Where the Company provides secondary service, the Company's transformer is standard for service delivery voltages offered in the Company's [Electricity Tariff](#); see Section 3 in [ESB 750](#). Non-standard transformers are not provided by the Company. The Company will determine when dedicated services and a dedicated transformer are required in order to reduce the impact on other adjacent customers. The need for a dedicated transformer(s) may be determined at any point in the DG systems' life cycle. If a dedicated transformer(s) is required, the Customer-Generator will be advised by the Company in writing. The cost of the transformer(s) will be the responsibility of the Customer-Generator according to the [Electricity Tariff](#) and as permitted by the NY SIR.

5.5.3 Primary and Higher Voltage Served Customer-Generators

The Company reserves the right to specify the winding connections for the Customer-Generator's "step-up" transformer between the Company's delivery point and the Customer-Generator's DG system output terminals as well as whether it is to be

grounded or ungrounded. The Customer-Generator shall provide their interface “step-up” transformer’s specifications and ratings for the Company’s review and acceptance.

5.5.3.1 Effectively Grounded, Four-wire Multi-grounded 3-phase Wye EPS:

The Company requires that the Customer-Generator selects their interface transformer’s winding configurations so that the DG system is interconnected effectively grounded. This can be accomplished with the following configurations:

1. A wye-grounded to wye-grounded transformer with a grounded generator source.
2. A wye-grounded connected primary winding with a fully insulated neutral and the secondary winding to have a delta connection. The insulated neutral is to establish provisions for the addition of a grounding reactor or grounding resistor in the event the generator's contribution to faults on the Company’s EPS results in undesirable fault current values.
3. A wye-grounded to wye-grounded transformer with a grounding transformer on the interconnection transformer secondary side.
4. A wye-grounded to wye-grounded transformer with a grounding transformer on the interconnection transformer primary side.

5.5.3.2 Not Effectively Grounded, Three-wire 3-phase EPS:

On three-phase Company EPS circuits other than effectively grounded, only the connection of ungrounded primary interface transformers shall be permitted. A delta primary is normally required. Refer to Section 5.3.4 for specific grounding requirements.

5.6 Manual Generator Disconnect Switch

1. According to the NY SIR, inverter-based DG systems 25 kW and below are not required to have a separate disconnect if the unit has a disconnecting means integrated into the design and meets the requirements of the NEC.
2. For those DG systems requiring a disconnect switch, these isolation devices shall meet applicable Underwriters Laboratories (UL), American National Standards Institute (ANSI), and IEEE standards, and shall be installed to meet the NEC and all applicable local, state, and federal codes.
3. The customer’s DG system shall have an electrical load break disconnect switch accessible at all times to the Company to electrically isolate the Company’s Distribution EPS from the customer’s DG system.
4. In accordance with the Company’s safety rules and practices, this isolation device must be used to establish a visually open, working clearance boundary when performing maintenance and repair work. The designated generator disconnect also must be accessible and lockable in the open position and have provisions for both Company and Customer-Generator padlocks.

Site-specific technical requirements will be considered by the Company if permitted to grant draw-out breakers with the provision for padlocking at the draw-out position, above 600 volts or with a full load output of greater than 960A, that are proposed to meet these isolation requirements. If the Company grants such use, the Customer-Generator will be required, upon the Company’s request, to provide qualified operating personnel to open the draw-out circuit breaker and ensure isolation of the DG system, with such operation to be witnessed by the Company followed immediately by the Company locking the device to prevent re-energization. In an emergency or outage situation, where there is no access to the draw-out breaker or no qualified personnel, the Company may disconnect the electric service to the premise to isolate the DG system.

5. The visible generator disconnect switch must be a blade-type switch (“knife switch”) meeting the requirements of the NEC and nationally recognized product standards. Pull-out

switches commonly used in air-conditioning units and spas are not permitted for this application.

6. The connection of the disconnect switch shall have the line connection (i.e., jaw side) of the switch made to the utility source.
7. Additionally, the Customer-Generator is solely responsible for the maintenance of all fuses in fused, blade-type disconnect switches.
8. This disconnect device shall be identified by a permanent sign as required by the NEC and the NY SIR.

5.7 Generator Interrupting Device Requirements

5.7.1 General

1. The generator interrupting device shall be designed to ensure the interrupting of the DG system upon loss of interrupting device supply power, or upon loss of local power supply source.
2. When a local power supply source is utilized, generator interconnection interrupting devices shall have DC trip coils and tripping energy.

5.7.2 Local Power Supply Requirements

When a continuous local power supply is proposed to comply with the Company's protection element operational requirements to safely remove the generation from the EPS the following conditions shall be met:

1. Failure of an uninterruptible power supply (UPS) rectifier shall not inhibit relay power supply and operation from the local power supply.
2. A fail-safe alarm contact shall be incorporated into the control trip scheme of the generator main interrupting device for loss of local power supply charge source.
3. The local power supply shall be sized to ensure successful operation of generator interrupting device upon loss of charge source. This supply shall be capable of providing all power requirements to initiate and complete the entire operating process of tripping the interconnection interrupting device.
4. The local power supply system shall be hard-wired and permanently installed. Portable cord-and-plug devices are prohibited.
5. System design calculations in accordance with IEEE standards and other industry standards as applicable shall be provided by the Customer-Generator for supply voltage, capacity specifications, and charging system provisions and are subject to the Company's review and acceptance.

5.8 Protection and Protective Equipment Requirements

5.8.1 Instrument Transformers for Protective Device Relays

5.8.1.1 Current Transformers ("CT")

CT ratios and accuracy classes shall be chosen such that secondary current is less than or equal to 5 amperes under normal operation and 100 amperes under maximum fault conditions. The transformation errors shall be consistent with Company practices. Meter selector switches shall not be connected into the secondary circuits of current transformers used with protective relays specified by the Company.

5.8.1.2 Voltage Transformers ("VT") and Connections

The DG system shall be equipped with a direct voltage connection or a VT, connected in accordance with the Company's requirements. The Customer-Generator shall follow the design requirements in the NY SIR for proper installation pertaining to voltage and frequency protection.

5.8.2 Protective Relay Power Requirements

Microprocessor-based relays shall be self-powered or DC-powered from a local power supply. Where Company approved non-latching interconnecting contactors are utilized, AC-powered relaying may be permitted provided the relay as well as its method of application are fail-safe, in which if the relay fails or if the voltage and/or frequency of its AC power source deviate from the relay's design requirements, the relay or separate fail-safe power monitoring relay acceptable to the Company will immediately trip the generator.

5.8.3 Protective Relay and Trip Circuit Hard-Wire Requirements

Unless authorized otherwise by the Company, protective relays shall be hardwired to the device they are tripping. Further, interposing computer-based or programmable logic controllers, auxiliary modules, or the like are not permitted in the trip control scheme between the relay and the device being tripped.

Generator protective relays shall be located no greater than 30 feet from the device in which they control.

5.8.4 Type Tested Equipment

Protective equipment that has been type tested and recognized by the NY SIR will be permitted. See the PSC's [list of certified interconnection equipment](#) on the NYS PSC's website

(<http://www3.dps.ny.gov/W/PSCWeb.nsf/All/DCF68EFCA391AD6085257687006F396B?OpenDocument>).

The Customer-Generator shall follow the testing requirements as outlined in Rule 53 of the [Electricity Tariff](#) and the [NY SIR](#). **Exhibit 7** attached hereto is a guide for the Company's witness for verifying a type tested net-metered DG system' operational compliance.

5.8.5 Non-Type Tested Equipment

1. Protective equipment that has not been type tested per the NY SIR will be permitted with the implementation of utility grade protective devices acceptable to the Company. The use of utility grade relays and relay redundancy is acceptable subject to prior Company review and acceptance.
2. **Use of Microprocessor-Based Relays**

Number of Relays Required:

Where relay performance may affect the operation of the Company's Distribution EPS at service voltages less than 15 kV, a single microprocessor-based relay along with a Company approved scheme, where relay failure automatically trips the associated breaker(s), is acceptable. If the Customer-Generator decides not to use redundant microprocessor-based protection systems on their other equipment, then appropriate action such as removing equipment from service shall be taken when a piece of equipment is no longer adequately protected.

Test Switches:

Microprocessor relays shall have ABB FT-1, or equivalent, test switches isolating all inputs and outputs of the relay.

- **AC Inputs:** Each relay shall have its own AC test switch. DC inputs or outputs are not permitted on AC test switches.
- **DC Inputs and Outputs:**
 - For relays designated by the Company as necessary to protect the Company's Distribution EPS, it is required that each individual relay have its own DC test switch that isolates the positive and negative DC for each input and output.
 - For relays required to protect the Customer-Generator's equipment, it is preferred that each relay have its own DC test switch for inputs and outputs. For ease of maintenance testing and troubleshooting, it is preferred to isolate the positive and negative DC of the input and output.

- Groups of relays that protect the same piece of equipment, such as a transformer or a feeder, may share a DC test switch under the following conditions:
 - The individual blades of the test switch shall be grouped by relay.
 - A permanent label shall be affixed to the relay panel identifying the use of each blade.

5.8.6 Solar Photovoltaic (PV) Generation Requirements

IEEE 1547 compliant and UL-1741 certified inverters shall be equipped with an internal active anti-islanding scheme with under voltage (27), over voltage (59), under frequency (81U) and over frequency (81O) relays.

5.8.6.1 Individual Inverter-based Solar PV Generator Equal or Above 500 kW

IEEE 1547 compliant and UL-1741 listed inverter internal relay functions are considered as primary protection. The Company requires one additional utility grade relay to be installed as secondary protection for inverter-based solar PV generation equal or greater than 500 kW. The 27, 59, 81U/O and voltage controlled overcurrent 51C (Phase and Ground) elements shall be activated in the secondary protection relay. The utility grade relay failure alarm shall be wired to initiate trip to the Company-designated generator interrupting device.

5.8.6.2 Individual Inverter-based Solar PV Generator Below 500 kW

If the inverter is IEEE 1547 compliant and UL-1741 listed, the internal relays are considered as the only required protection and an additional utility grade relay is not necessary to be installed. At the Company's sole discretion the Company reserves the right to require redundant utility grade relays for systems above 300 kW with, at minimum, functions 27, 59, 81U/O and voltage controlled overcurrent 51C.

5.8.7 Utility Grade Protective Device Settings and Verification

5.8.7.1 Company-designated Relays and Customer-Generator Settings

The Company will review the Customer-Generator's settings and the calibration and test results of those relays that the Company designates as being required to satisfy the Company's protection practices. Any relay setting specified by the Company shall not be changed or modified at any time without the prior written consent of the Company.

5.8.7.2 Company Verification of Relay Testing

The Company requires a letter from the Customer-Generator stipulating that all Company-designated protective devices shall have:

- control wiring verified against the accepted design drawings, and
- the calibration test performed satisfactorily according to the relay setting document of the accepted design.

The Company reserves the right to witness the Customer-Generator's functional test of the required devices, i.e., trip tests. This activity will normally be performed on a schedule as specified by Rule 53 of the [Electricity Tariff](#) and the NY SIR.

The Customer-Generator shall be responsible to specify the settings, calibrate, test, and maintain the balance of their equipment.

5.8.8 Anti-islanding

The Customer's DG system will not be permitted to energize a de-energized Company circuit; therefore, anti-islanding protection is required for parallel generation on the Company's Distribution EPS. If the Company determines that an active anti-islanding protection scheme is required to mitigate the risk of a formation of an island in addition to the generator facility's own anti-islanding control scheme then the Customer-Generator may propose alternative methods of anti-islanding protection of their own generation facility. It is the Customer-Generator's responsibility to demonstrate comprehensively

the validity of such methods and the Company reserves the right to make the final determination as to which anti-islanding protection method is suitable to meet the EPS safety and reliability requirements. The use of direct transfer trip (DTT) is a definitive protection means for anti-islanding protection under good utility practice.

Note: A Customer wishing to use a generation system as a stand-by or emergency generator shall submit details regarding an interlocking scheme or transfer switch to prevent the energization of a de-energized Company circuit that complies with National Grid ESB 750, Section 11.

6.0 OPERATING

6.1 Power Factor

The DG system shall maintain a power factor at the PCC in accordance with the NY SIR; at or between 0.90 leading or lagging (Var or voltage support can also be considered within machine ratings). Corrective equipment may be required and, if so, it will be at the Customer-Generator's expense; refer to ESB 750. It is the Company's expectation that the Customer-Generator will strive to maintain a power factor at their service point that does not adversely affect the power quality (PQ) of the Company's EPS; see [ESB 750](#).

6.2 Power Quality Monitoring

6.2.1 Power Quality Compliance Verification

If during the study the interconnection of a DG system is identified as having the potential to cause power quality (PQ) effects on the Company's Distribution EPS, then PQ monitoring shall be installed by the Company or Company-accepted third party PQ testing company to verify power quality with and without generation. Third party PQ test methods and results may be submitted to the Company for review and acceptance. These verification tests shall include, at a minimum, the following in accordance with the Company's [Electricity Tariff](#) and the limits and cost responsibilities specified in the NY SIR:

- Check service point voltage for any discernible voltage fluctuation.
- Check service point frequency for any discernible frequency fluctuation.
- Check PCC power factor to ensure it is no less than 90% (leading or lagging).
- Check service point harmonic distortion to ensure limits specified in ESB 750 and the NY SIR as applicable, are maintained. Current harmonic distortion shall not adversely affect voltage harmonic distortion, the Company's Distribution EPS, or service to other customers.

6.2.2 Power Quality Disturbance and Mitigation

1. If disturbances on the Company's Distribution EPS and/or to other customers are determined to originate from a customer with an installed DG system, PQ monitoring shall be installed to verify power quality in accordance with the Company's [Electricity Tariff](#).
2. **If any power quality concerns cannot be corrected, the Customer-Generator will not be permitted to continue generation until such concerns are resolved to the Company's satisfaction.**

6.3 Isolation

The Company reserves the right to have the Customer-Generator remove their DG system from the Company's Distribution EPS at any time upon the Company's request. Normally, such requests result from the need to facilitate maintenance, testing, or repair of Company facilities. The Customer's generator disconnect switch* may be opened by the Company (i.e., isolating the Customer's generating equipment), without prior notice to the Customer-Generator, for any of the following reasons:

- System emergency operations require such action.

- Company periodic checks of Customer-Generator's interfacing equipment reveal a hazardous condition.
- Generating equipment interferes with other customers or with the operation of the Company EPS.
- Protective device tampering.
- Parallel operation, other than for NY SIR testing of type tested inverters, prior to Company approval to interconnect.
- Failure to make available records of verification tests and maintenance of the Customer-Generator's protective devices designated by the Company.

* Refer to Section 5.6.4 regarding technical requirements for draw-out breakers over 600V and the Company's [Electricity Tariff](#) for limitations of service.

6.4 Energy Management System-Remote Terminal Unit (EMS-RTU)

1. The Company requires an EMS-RTU for status and control of the generator for the following conditions:
 - 300 kW or greater for DG systems connected to the Company's Distribution EPS of 5 kV or below.
 - 1 MW or greater for DG systems connected to the Company's Distribution EPS greater than 5 kV but less than 15 kV.
 - 1.8 MW or greater for DG systems connected to the Company's Distribution EPS greater than 15 kV but less than 35 kV.

EMS-RTU installations may be required for DG applications not covered by the conditions above as determined by the Company on a case-by-case basis. One situation where an EMS-RTU may be required is where there is Distribution EPS feeder selectivity operation.

The control portion would only involve the remote trip and block closing of the Customer-Generator's interrupting device(s) designated by the Company. The block close function will be performed by control circuitry and is subject to review by the Company for acceptance.

2. The required inputs from the RTU to the Company's EMS shall be as follows:
 - Status of individual generator breakers
 - Status of main or interconnect breaker at the PCC
 - Control input for the "designated generator interrupting device"
 - Three phase line current for each generator
 - Three phase line current at the PCC with the Company
 - Three phase line-to-line voltage for each generator
 - Three phase line-to-line voltage at the PCC with the Company
 - Output kW for each unit (+ delivered to the Company, - received)
 - Output kVAR for each unit (+ delivered to the Company, - received)
 - Total MW (+ delivered, - received) at the PCC
 - Total MVAR (+ delivered, - received) at the PCC

Exceptions to the above list may be considered by the Company on a case-by-case basis.

Note: The Company will provide an EMS-RTU point list for inputs required at the DG system.

3. When a Company EMS-RTU is specified for a parallel generation project, the Company will determine the requirements for equipment, installation, and communications media in the interconnection study for the DG system. The Customer-Generator will be responsible for all initial and recurring costs associated with communications for their RTU.

6.5 Balance of Customer-Generator Equipment

1. The Customer-Generator is responsible for performing all operating functions associated with their equipment and for maintaining all equipment under their ownership. The Customer-Generator shall arrange to have trained personnel available for the proper and safe operation of their equipment.
2. The Customer-Generator shall provide proper and continuous maintenance of all DG systems; refer to National Fire Protection Association (NFPA) recommended practice NFPA 70B (and NFPA 73 where applicable) and other nationally recognized industry guides for guidance on electric equipment maintenance.
3. The Customer-Generator's service and backup service requirements from the Company's system shall be requested using the prescribed forms in the Company's [Electricity Tariff](#).
4. Where the Company is requested to supply demand pulse information (either analog or digital), its use is not intended for generation dispatch or control.

7.0 REVISION HISTORY

<u>Version</u>	<u>Date</u>	<u>Description of Revision</u>
1.0	06/01/07	Initial version of new document superseding all previous revisions of ESB 756.
2.0	09/06/11	Revise entire document for Dec. 2010 NY SIR.
3.0	09/22/14	Revise entire document for Apr. 2013 & Feb. 2014 NY SIR and technical updates in Sections 4, 5, and 6.

EXHIBITS ATTACHED

EXHIBIT 1: Niagara Mohawk Power Corp. Electricity Tariff PSC No. 220, Rule 53

https://www2.dps.ny.gov/ETS/search/searchShortcutEffective.cfm?companyID=3569016&serviceType=ELECTRIC&psc_num=220

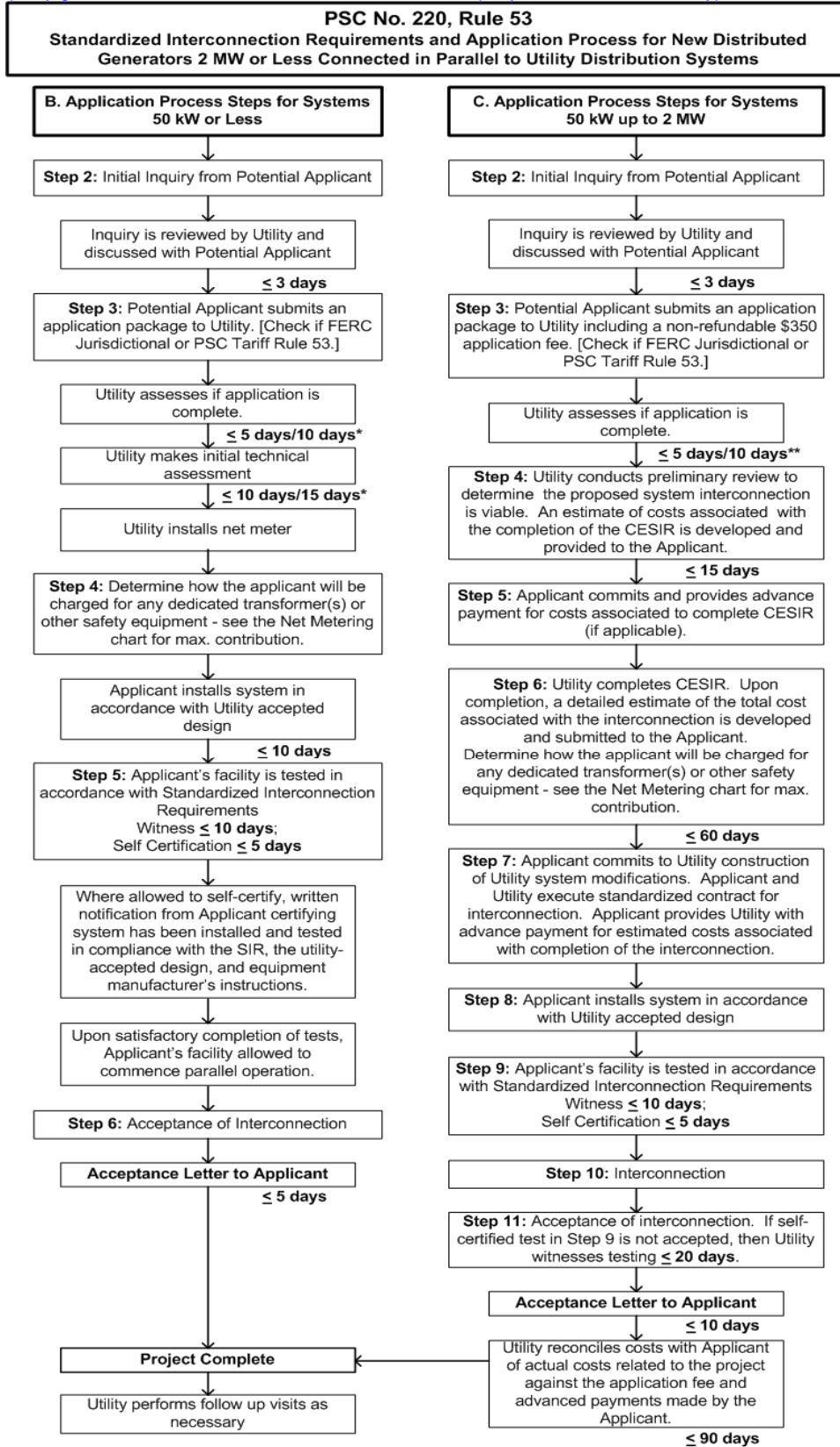

Notes:
 "days" are "business days"
 * For non-inverter or network systems
 ** For network systems

EXHIBIT 2: Company Requirements for DG Systems Not Eligible for the Expedited Process

These are Company items to be considered in the Customer-Generator's DG System Project Schedule.

ID	Activity Description	NY SIR §I.C / ESB ref.
Project Definition & Conceptual Analysis Phase		
1	Customer-Generator Form K w/technical submittal & prelim. design received	Steps 1 - 3
2	Company Preliminary Technical Assessment & cost estimate for CESIR	Step 4
3	Company Form K Interconnection Agreement and Form G as needed are executed with Customer-Generator	Step 5
4	Customer-Generator commits to final CESIR and provides advance payment	Step 5
Preliminary Design Review Phase		
ESB 751 Stage A		
5	Customer-Generator's preliminary project schedule, design, specifications, test reports, and protective device settings received.	Step 6
6	Company final CESIR and Interconnection Service Plan with Planning Grade construction estimate	Step 6
7	Company reviews Customer-Generator preliminary design & returns comments	Step 6
Final Design Review Phase		
ESB 751 Stage B		
8	Customer-Generator commits to utility system modifications in CESIR & Interconnection Service Plan and provides advance payment	Step 7
9	Customer-Generator's project schedule, final design, specifications, & protective device coordination analysis received	Step 7; ESB 750 & 752 or 753 or 754 or 758
10	Company reviews Customer-Generator's design & returns comments	Step 8; ESB 752 or 753 or 754 or 758
Installation Progress Review Phase		
ESB 751 Stage C		
11	Customer-Generator's corrected design, test reports, & protective device settings received	Step 8; ESB 752 or 753 or 754 or 758
12	Company reviews Customer-Generator's design & returns comments	Step 8; ESB 752 or 753 or 754 or 758
Installation Compliance Verification Phase		
ESB 751 Stage D		
13	Customer-Generator's advance notice of functional testing received	Step 9; ESB 755
14	Electrical inspection certification approval received from municipal or AHJ authorized 3 rd party agency	ESB 750 & 752 or 753 or 754 or 758; Local AHJ
15	Customer-Generator's acknowledgement of satisfactory wiring & relay calibration tests received	Steps 9 & 10; ESB 755
16	Company witness of Customer-Generator's functional testing	Step 10; ESB 755
17	Company field audit of Customer-Generator's service connection	Steps 8 - 10; ESB 750 & 752 or 753 or 754 or 758
18	Customer-Generator resolves open compliance verification items	Steps 8 - 10; ESB 750 & 752 or 753 or 754 or 758
19	Verification testing satisfied	Steps 9 & 10
Energization & Synchronization Phase		
ESB 751 Stage E		
20	Company's metering installation complete	Steps 8 - 10; ESB 750 & 752 or 753 or 754 or 758
21	Customer-Generator's energization sequence plan received for interconnections > 600 V	Steps 9 & 10; ESB 755
22	Company's supply system interconnection complete	Steps 9 & 10
23	Company review/acceptance of Customer-Generator's resolved open items in 18 above.	Steps 9 & 10
24	Company proceeds with energization	Steps 9 & 10
25	Customer-Generator is permitted to synchronize generation facility in parallel to the Company's supply	Step 10
Project Closeout Phase		
ESB 751 Stage F		
26	For interconnections > 600 V, remainder of Customer-Generator's protective system functional testing documented in an acknowledgement letter submitted to the Company within 10 business days after energization	Step 11; ESB 755
27	Customer-Generator's as-built design drawings received within 90 days for interconnections > 600 V	Step 11; ESB 750 § 1.7
28	Company reconciliation of project costs with Customer-Generator within 90 days of as-built documents received.	Step 11

EXHIBIT 3: Reference Maps of National Grid upstate NY Secondary Network EPS Areas

NY Central Division

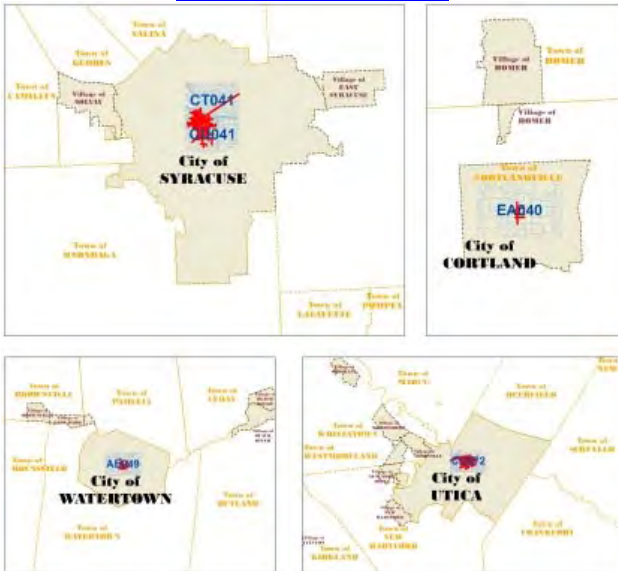

NY Eastern Division

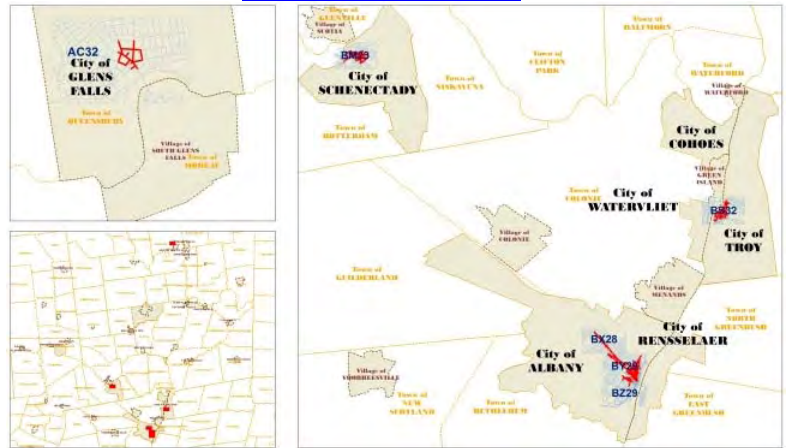

National Grid customers in the downtown districts of Albany, Buffalo, Cortland, Glens Falls, Niagara Falls, Schenectady, Syracuse, Troy, Utica, and Watertown can refer to the following Internet web site to view maps of National Grid's Secondary Networks and determine if the proposed location is served in those areas.

http://www.nationalgridus.com/niagaramohawk/home/energyeff/4_networkmap.asp

NY Western Division

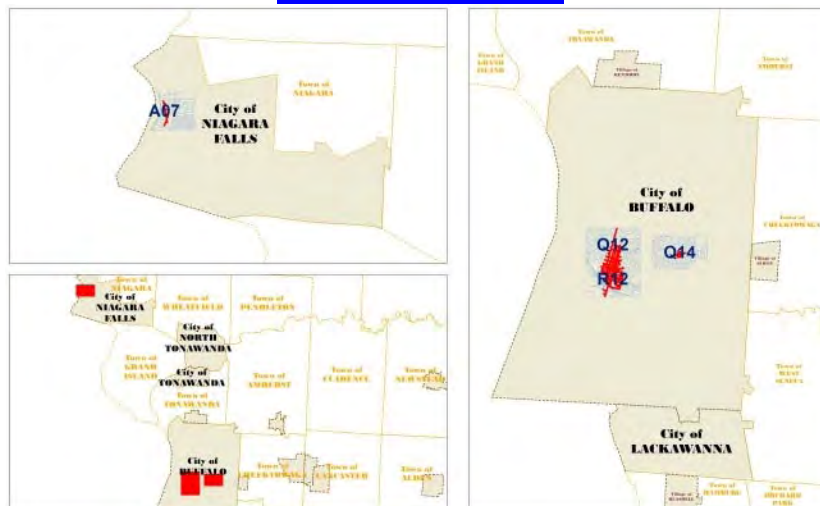

EXHIBIT 4: Distribution Secondary Grid and Spot Network Description

In Upstate New York, National Grid generally has two types of electrical distribution systems: radial and distribution secondary network systems. While the vast majority of customers are served from radial power systems, some customers in the downtown districts of Albany, Buffalo, Cortland, Glens Falls, Niagara Falls, Schenectady, Syracuse, Troy, Utica, and Watertown are served by distribution secondary network systems; see **Exhibit 3** for area maps. These systems are designed to meet the higher reliability needs, dense load levels, and limited space commonly encountered in urban areas.

A distribution secondary network system delivers electricity through a complex and integrated system of transformers and underground cables that are connected and operate in parallel. Power can flow in either direction on the secondary service delivery lines, commonly called secondary distribution lines. The loss of a single line or transformer in a secondary network system does not cause an interruption of power, unlike radial systems where there is only one line and one path for power to flow from the distribution substation to the customer's point of service. If a radial system experiences an outage, service is interrupted to the customers until repairs are completed; this is less likely to be the case in a distribution secondary network system.

In distribution secondary network systems, devices called "network protectors" are usually arranged to automatically connect its associated transformer to the network system when conditions are such that the transformer when connected will supply power to the network and to automatically disconnect the transformer from the network when power flows from the network to the transformer. The integration of DG into a distribution secondary network system may result in network protectors exceeding their original design criteria or nameplate ratings.

Example Distribution Secondary Grid Network Diagram

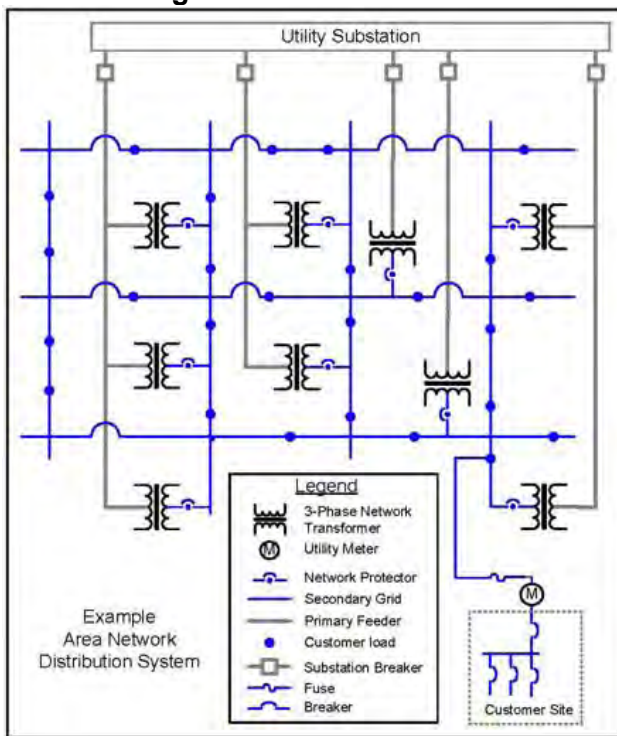

Underground secondary grid (area) network systems deliver power to each customer through a complex and integrated system of multiple transformers and underground cables that are connected and operate in parallel.

Example Distribution Secondary Spot Network Diagram

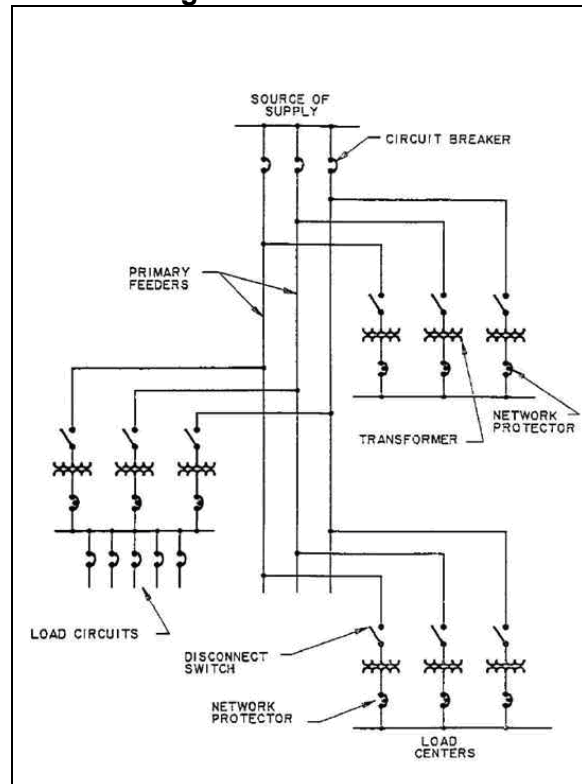

Spot networks are similar to grid (area) networks except they serve a single premise.

EXHIBIT 5: Recommended Guidelines for Residential and Commercial Single-line Diagram Submittals

Refer to **Figures 1 and 2** for typical illustration and symbology.

1. Identify the project, Company's electric service order (ESO) number, location and submitter's name and address.
2. Indicate standard and any non-standard system voltages, number of phases, and frequency of the incoming circuit. Indicate wye and delta systems; show whether grounded or ungrounded.
3. Identify cable, conductors and conduit, the type and number. The Company is interested in how the power is getting from the service point to the protective equipment.
4. Identify wiring troughs and/or junction boxes where used.
5. Use standard symbols. See **NFPA 70B** or **IEEE Standard 141** for symbols in typical electrical single-line diagram development.
6. Identify the service equipment's switch and fuse or circuit breaker as to manufacturer, type, rating, catalog number, etc. Service equipment must be able to safely interrupt the maximum available fault current from the supply; refer to **NEC** Articles 110 and 230.
7. Show billing meter trough or instrument transformers' cabinet (C.T. cabinet) in circuitry. Indicate source and load for the circuit. Refer to Section 7 in the Company's **ESB 750** for acceptable metering configurations.
8. Identify other protective devices and ratings. Include ratings in volts and amps, the interruption rating, and type and number of trip coils on circuit breakers. Also, note any special features of fuses (current limiting, dual element, etc.).
9. Identify ratios of current and potential transformers, taps to be used on multi-ratio transformers, and connection of dual ratio current transformers if used.
10. Identify any relays, if used, and their functions.
11. Show connections and ratings of power transformer windings for any to be used.
12. Identify Generator Disconnect and its ratings, the service point, and the PCC.
13. Provide catalog cut-sheets clearly identifying exact model to be installed for devices and equipment of mutual interest to the Company and of the Customer-Generator. Equipment shall be inclusive but not limited to the main service arrangement, any transformer in the circuit path between the point of common coupling and the generator, the generator interrupting device, the utility disconnect, and inverter(s) and/or relay(s).

FIGURE 1: Sample Distributed Generator One-Line Diagram

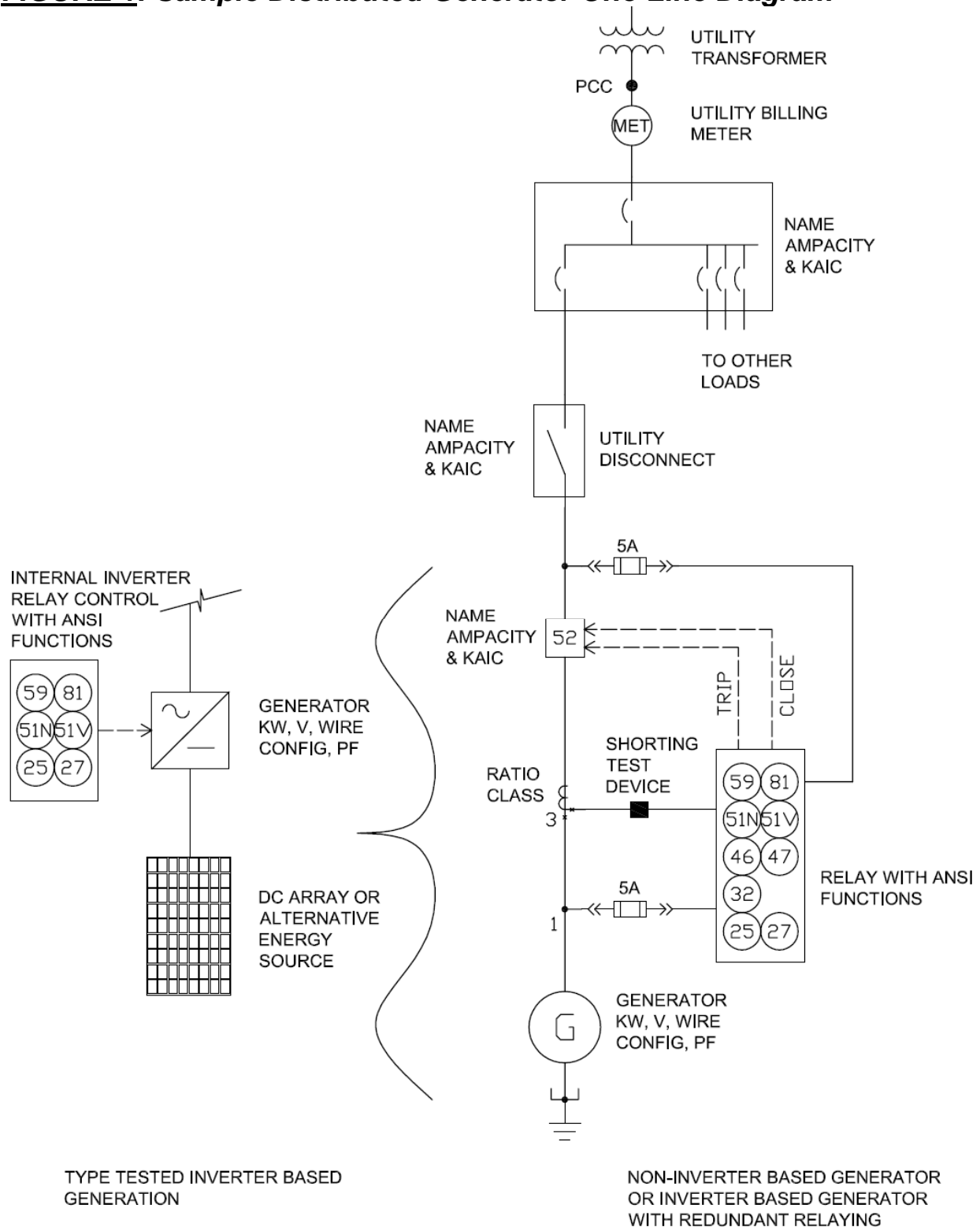

[TYPICAL ONLY]

FIGURE 2: Typical Symbolology for Electrical Drawings

ELEMENTARY SWITCH DEVICES								CONTACTS AND RELAYS	
FLOW		PRESSURE		LIQUID LEVEL		TEMPERATURE		CONTACTS	
CLOSED RISING	OPENS RISING	CLOSED RISING	OPENS RISING	CLOSED RISING	OPENS RISING	CLOSED RISING	OPENS RISING	NORMALLY OPEN OR "a" CONTACT	NORMALLY CLOSED OR "b" CONTACT
LIMIT				PUSHBUTTON		RELAY COIL			
NORMALLY OPEN	NORMALLY OPEN - HELD CLOSED	NORMALLY CLOSED	NORMALLY CLOSED - HELD OPEN	NORMALLY OPEN	NORMALLY CLOSED				
ELEMENTARY FUSE DEVICES			BATTERY OR DC SOURCE			CONNECTIONS			
FUSE	SOLID LINK	IN REMOVABLE CARTRIDGE OR PULL BLOCK	GENERAL OR SINGLE CELL	MULTI CELL (COMMON)	GROUND	SHORT CIRCUIT (3-PHASE CONNECTION)	SEPARABLE CONNECTORS OR DRAW OUT FEATURE		
DISCONNECTS (UNDER 600 V)		CIRCUIT BREAKERS			TRANSFER SWITCH				
NON-FUSED DISCONNECT	FUSED DISCONNECT	GENERIC OR AIR TYPE	CB OR INTERRUPTING DEVICE (OTHER THAN AIR)		TWO POSITION	THREE POSITION			
CAPACITOR	ANTENNA	THERMAL OVERLOAD	INDICATING LIGHT * = LENS COLOR:						
			A - AMBER B - BLUE C - CLEAR G - GREEN O - ORANGE P - PURPLE R - RED W - WHITE Y - YELLOW						
TRANSFORMERS AND INSTRUMENT TRANSFORMERS									
3-PHASE, WYE		3-PHASE, DELTA					3-PHASE ZIGZAG		
GROUND NEUTRAL	UNGROUND	DELTA	CORNER GROUNDED	OPEN DELTA	OPEN DELTA CORNER GROUNDED	BROKEN DELTA	UNGROUND	GROUNDED	
GENERIC TWO WINDING TRANSFORMER	GENERIC THREE WINDING TRANSFORMER, TERTIARY TYPE		CURRENT TRANS. WITH POLARITY MARKS SHOWN		FUSED POTENTIAL TRANSFORMER				

EXHIBIT 6: Recommended Guidelines for Functional Single-line Diagram Submittals

Refer to **Figures 3** and **4** for typical illustrations.

In addition to **Exhibit 5**:

14. On functional single-line diagram submittals, industry standard device numbers are necessary. Refer to the following List of Standard Device Numbers (See latest edition of **ANSI C 37.2**):

<u>Device Number</u>	<u>Function</u>
25	Synchronizing Device
27	Undervoltage Relay
32	Directional Power Relay
46	Negative Sequence Voltage
50	Instantaneous Overcurrent Relay
51	Phase Overcurrent Relay
51C	Voltage Controlled Overcurrent Relay
51N	Neutral Overcurrent Relay
51V	Overcurrent Relay, voltage restraint
52	Breaker
52R	Recloser
59	Overvoltage Relay
59G	Neutral Voltage Relay
59N	Zero Sequence Voltage Relay
62	Time-delay Stopping or Opening Relay
64	Ground Protective Relay
81	Over and Under Frequency Relay
86	Locking - Out Relay
87	Differential Relay

FIGURE 3: Sample Functional Single-Line Diagram

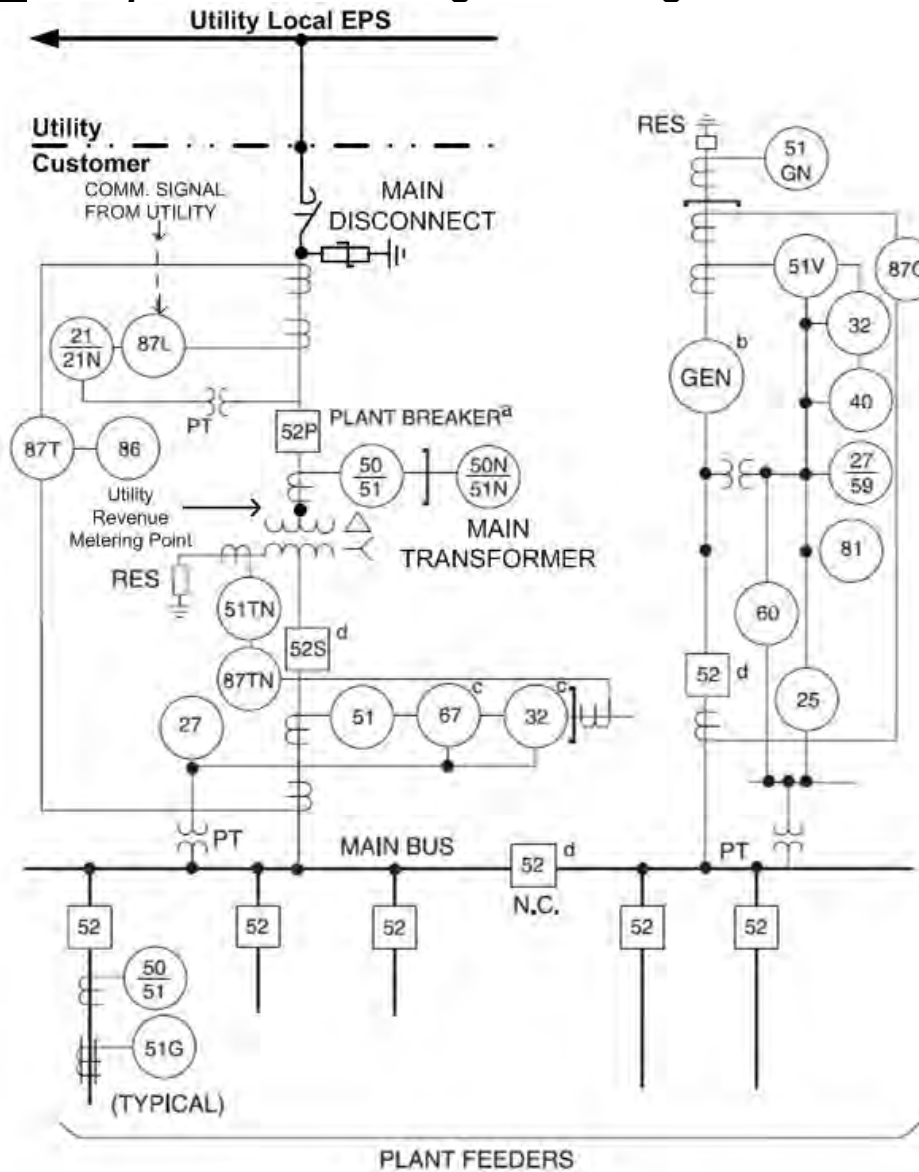

- NOTES:
- a. A fused interrupter switch may also be used instead of the breaker.
If fused interrupter is used, relaying associated with the transformer is not used.
 - b. In-plant generator for partial plant load and back-up.
 - c. Devices 67 and 32 are directional. Polarity of CTs and PTs must be verified.
 - d. Overcurrent and bus differential protection should be provided for the main, generator, and tie breakers, but protection is not shown here. See IEEE Std. C37.95 and C37.97.
- Trip function lines not shown.
See IEEE Std. 242 Buff Book "Recommended Practice for Protection and Coordination of Industrial and Commercial Power Systems" for more information.

[TYPICAL ONLY]

FIGURE 4: Typical $3V_0$ Requirements for Local EPS Ground Fault Detection

The Company requires ground fault protection on any system that can be a generation source to protect any equipment that can be parallel supplied from two sources. In the cases where the primary winding of the transformer supplying the facility is delta, a “zero-sequence” voltage or “ $3V_0$ ” scheme is required. Typically, this is implemented by installing potential transformers (PTs) on the primary system as a source to a voltage sensing relay containing a ground overvoltage device function (59N or 59G) capable of detecting the presence of a single line-to-ground fault on the Local EPS.

Notes:

1. The Company may waive this requirement depending on the restrictions of the local EPS.
2. Trip signal is shown to remove generator from Company's EPS at the generator interrupting device. Alternatives may be proposed for Company approval for alternative arrangements.

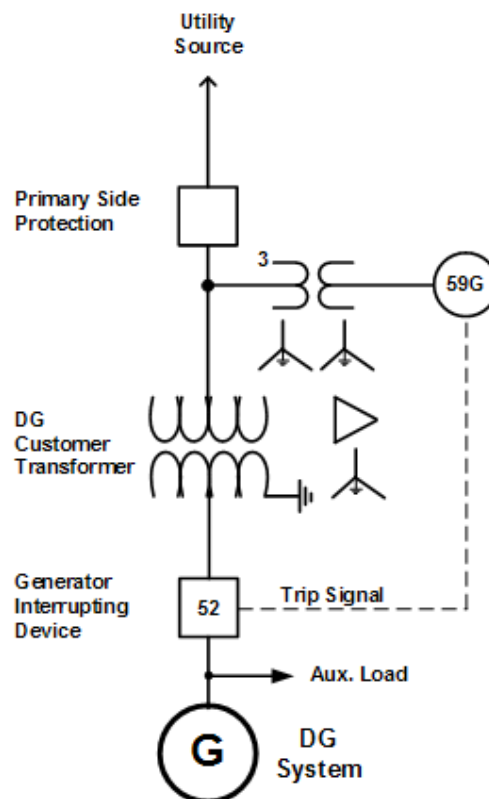

-- INFORMATION ONLY --
 -- SIMPLIFIED DIAGRAM NOT ALL DETAILS SHOWN --

EXHIBIT 7: Net Metering Compliance Verification Checklist

Account Number: _____

Customer Name: _____ Phone # _____
Last First Work Phone # _____

Service Address: _____
Number Street Town/City Zip

Billing Address: _____
Number Street Town/City Zip

Qualified Installer: _____ License # _____ Phone # _____
Last First (if available) Cellular # _____

Address: _____ FAX # _____
Number Street Town/City Zip Pager # _____

✓ Verify One-Line Diagram (installed equipment)

_____ Inverter Model _____ or Intertie Multifunction Relay Model _____

_____ Software version _____

_____ Company billing meter s/n _____ Net-meter One Meter Option: YES___NO___

_____ Inspection received? YES___Number _____ (attach copy of approval certificate)
NO___, then stop and await inspection approval.

✓ Verify Plot Plan (equipment's location)

_____ "Generator Disconnect Switch" is at agreed location: YES___NO___.

_____ "Generator Disconnect Switch" is labeled as such: YES___NO___.

_____ Label is at meter location to identify location of Generator Disconnect: YES___NO___.

✓ Verify DG System Is Operating (producing power)

_____ Verify "Generator Disconnect Switch" is Open.

_____ Verify voltage is **zero volts** on DG side of open "Generator Disconnect Switch": YES___NO___.

_____ Close "Generator Disconnect Switch".

_____ Verify DG Inverter or Intertie Multifunction Relay alarms and **voltage present** on utility side of "Generator Disconnect Switch": YES___NO___.

✓ Restoration of Utility Power Test

_____ Open "Generator Disconnect Switch", **pause at least 1 to 2 minutes**, then Close "Generator Disconnect Switch". Record time when "Generator Disconnect Switch" is closed: _____

_____ Record time when **DG starts** producing power: _____. Is the time between the "Generator Disconnect Switch" closure and when DG Inverter or Intertie Multifunction Relay permits synchronization to utility source **greater than 5 minutes**? YES___NO___

✓ 24 Hour Telephone Number Contact

Name: _____ Number (____) - _____

Performed by: _____ *signature*: _____ Date: _____
Name (Customer's qualified installer.)

Witnessed by: _____ *signature*: _____ Date: _____
Name (Company witness.)

Electric System Bulletin No. 756 Appendix C:
**Distributed Generation Connected To National Grid
Distribution Facilities Per The Massachusetts
Standards for Interconnecting Distributed Generation**

April 2012 version 2.0

ESB 756 Appendix C is part of the ESB 750 series



PREFACE

Electric System Bulletin 756 APPENDIX C is a technical bulletin covering Massachusetts Electric Company and Nantucket Electric Company d/b/a National Grid Standards for Interconnecting Distributed Generation M.D.P.U. No 1176* (Canceling M.D.T.E. No. 1116-A) Effective: December 1, 2009.

* https://www.nationalgridus.com/non_html/Interconnect_stds_MA.pdf

This is an appendix to ESB 756 and is available from the Company's web site and may be obtained:

- From the Internet at <http://www.nationalgridus.com/electricalspecifications>,
- Or in printed form by contacting either of the Call Centers in Massachusetts or New York (see inside cover of ESB 750). However, printed copies are not document controlled, so for the latest authorized version please refer to the Company's website.

TABLE of CONTENTS

SECTION	PAGE
TABLE of CONTENTS	3
1.0 Purpose	4
2.0 Scope	5
3.0 Customer Interface Procedures.....	5
3.1 APPLICATION PROCESS OVERVIEW	5
3.2 OBJECTIVES IN THE APPLICATION PROCESS.....	5
3.3 CONSIDERATIONS DURING THE APPLICATION PROCESS.....	7
3.4 INTERCONNECTION CHARGES.....	8
Table 3.4-1: DG Projects where no EPS upgrades are expected	8
Table 3.4-2: Complex DG Projects	8
4.0 Overview of Potential Issues Related to Interconnection.....	9
ILLUSTRATION 4.6-1: TYPICAL DG INSTALLATION AREAS ON RADIAL DISTRIBUTION FEEDERS....	10
TABLE 4.6-1: TYPICAL PLANNING LIMITS FOR DG CONNECTION TO RADIAL DISTRIBUTION FEEDER	10
5.0 General Design and Operating Requirements.....	12
5.1 APPLICABLE CODES, STANDARDS, AND GUIDELINES	12
5.2 DEFINITIONS	13
5.3 GENERAL CRITERIA	13
5.3.1 Single Phase	13
5.3.2 Three Phase.....	13
5.3.3 Phase Balance	13
5.3.4 Neutral Stabilization and Grounding.....	13
5.4 SERVICE EQUIPMENT AND REVENUE METERING.....	14
5.4.1 Service Equipment Requirements.....	14
5.4.2 Company Revenue Metering Requirements	14
5.5 TRANSFORMER	14
5.5.1 Purpose for DG Facility Interconnecting Transformer	14
5.5.2 Secondary Served DG Customers	14
5.5.3 Primary and Higher Voltage Served DG Customers	14
5.5.3.1 Effectively Grounded, Four-wire Multi-grounded 3-phase Wye EPS:.....	15
5.5.3.2 Not Effectively Grounded, Three-wire 3-phase EPS:	15
5.6 MANUAL GENERATOR DISCONNECT SWITCH	15
5.7 PROTECTIVE DEVICE EQUIPMENT	16
5.7.1 Protection Requirements.....	16
5.7.2 Interconnection Interrupting Device.....	16
5.7.3 Interconnection Transformer Configuration.....	16
5.7.4 Instrument Transformers for Protective Device Relays	16
5.7.4.1 Current Transformers (“CT”).....	16
5.7.4.2 Voltage Transformers (“VT”) and Connections.....	16
5.7.5 Synchronizing Devices	17
5.7.6 Voltage Relays	17
5.7.7 Frequency Relays	17
5.7.8 Overcurrent Relays	17
5.7.9 Type Tested Equipment	17
5.7.10 Non-Type Tested Equipment	17
5.7.10.1 Photovoltaic (PV) Generation	17
5.7.10.2 All Other Parallel Generation Equal or Above 500kW	18
5.7.10.3 Protective Relay Hard-Wire Requirement	18
5.7.10.4 Interconnection Interrupter Tripping and Protective Relay Supply	18
5.7.10.5 Use of Microprocessor Based Relays	18
5.7.11 Utility Grade Protective Device Settings and Verification	19
5.7.11.1 Company-designated Relays and Customer Settings.....	19

TABLE of CONTENTS

<u>SECTION</u>	<u>PAGE</u>
5.7.11.2 Company Verification of Relay Testing	19
5.7.12 Anti-islanding.....	19
5.7.12.1 Inverter-based Photovoltaic (PV) Generation	19
5.7.12.2 All Other Parallel Generation Except PV Generators	20
5.7.12.3 High-Speed Protection	20
5.7.12.4 DTT Installation Requirements	20
5.7.13 Power Quality Compliance Verification	20
6.0 OPERATING	21
6.1 POWER FACTOR	21
6.2 POWER QUALITY MONITORING	21
6.3 ISOLATION	21
6.4 ENERGY MANAGEMENT SYSTEM-REMOTE TERMINAL UNIT (EMS-RTU).....	21
6.5 BALANCE OF CUSTOMER EQUIPMENT.....	22
7.0 REVISION HISTORY	22
EXHIBITS ATTACHED.....	22
EXHIBIT 1: M.D.P.U. 1176 TARIFF.....	23
EXHIBIT 2: COMPANY REQUIREMENTS FOR PROJECTS NOT ELIGIBLE FOR THE SIMPLIFIED PROCESS.....	26
EXHIBIT 3: REFERENCE MAPS OF NATIONAL GRID MASSACHUSETTS SECONDARY NETWORK EPS AREAS.....	27
EXHIBIT 4: DISTRIBUTION SECONDARY GRID NETWORK DESCRIPTION.....	28
EXHIBIT 5: RECOMMENDED GUIDELINES FOR RESIDENTIAL AND COMMERCIAL SINGLE-LINE DIAGRAM SUBMITTALS	29
FIGURE 1: Sample Residential Photovoltaic Distributed Generator Installation – Single Phase, Net Metering.....	30
FIGURE 2: Sample Commercial Distributed Generator Installation	31
EXHIBIT 6: RECOMMENDED GUIDELINES FOR FUNCTIONAL SINGLE-LINE DIAGRAM SUBMITTALS.....	32
FIGURE 3: Sample Functional Single-Line Diagram.....	33
FIGURE 4: Typical 3V ₀ Requirements for Local EPS Ground Fault Detection.....	34
EXHIBIT 7: TYPICAL OVERHEAD PRIMARY SERVICE CONFIGURATION FOR LARGE DG INSTALLATIONS >500KW.....	35
EXHIBIT 8: NET METERING COMPLIANCE VERIFICATION CHECKLIST (SIMPLIFIED PROCESS)	36

1.0 Purpose

1. National Grid strongly believes that promoting the installation of Distributed Generation (DG) facilities, in accordance with the Massachusetts Standards for Interconnecting Distributed Generation (MA SIDG or SIDG), is sound public policy. This belief includes DG facilities on network systems to the extent technically feasible.
2. The purpose of this Electric System Bulletin (ESB) is to assist customers desiring to interconnect DG projects to National Grid's Massachusetts distribution system for State jurisdictional projects. If a project will be selling energy to a third party, not National Grid as a Qualifying Facility (QF) or under the net-metering tariff, then the project is FERC jurisdictional. As such, the Customer will need to apply and work with the ISO-NE (http://www.iso-ne.com/genrtion_resrcs/nwgen_inter/index.html) for interconnection to the distribution system, following the application requirements of the FERC Small Generator Interconnection Procedure (SGIP) and ISO-NE Schedule 23.
3. This ESB supplements **ESB 750** and the **MA SIDG** and provides general technical requirements, recommendations, and assistance to customers regarding the DG facilities connected in parallel to the Company's distribution electric power system (Company

Distribution EPS). These projects are typically 5 MWs or smaller in size. Note that the SIDG does not apply to DG units larger than 10 MW.

2.0 Scope

1. All generating interfacing equipment must be designed, installed, interconnected, tested, and operated in accordance with applicable government, industry, and Company standards. The provisions of this bulletin only pertain to those types of parallel generation covered by the MA SIDG connected to the Company Distribution EPS that are net metered generation sources (Net Metered Classes) or non-net metered generation sources. For FERC jurisdictional projects connected to the Company Distribution EPS, the technical provisions of this document also apply.
2. These requirements are limited to only those points in which the Customer and the Company have a mutual interest to ensure safety to Company employees and the public and satisfactory operation and compatibility with the electrical supply to others served by the Company distribution EPS.
3. Technical requirements for parallel operated on-site generators (OSG) not covered by this document may be found in [ESB 756 Appendix A](#).

3.0 Customer Interface Procedures

3.1 Application Process Overview

This section outlines the process for a Customer to receive Company approval to interconnect DG facilities to the Company Distribution EPS. This process is intended for the following:

1. New DG facilities that are eligible under the [MA SIDG](#) process;
2. Review of any modifications affecting the Company Distribution EPS and service connection interface at the point of common coupling (PCC) of existing Customer DG facilities that: (i) are eligible under the SIDG process; and (ii) have been interconnected to the Company Distribution EPS where an existing retail interconnection agreement between the Customer and the Company is in place; and
3. In all other cases, the Company will, where possible, use a similar application and approval process as outlined in the SIDG for DG types of facilities.

This application process and its requirements do not apply to generation equipment that will never be allowed to operate in parallel with the Company Distribution EPS. For example, this process does not apply to emergency standby generators with break-before-make transfer switches and any other generation sources that operate independently of any connection to the Company Distribution EPS and have no provision for such connection (even for a short period of time).

As stated above, this application process is mandated by the Massachusetts Department of Public Utilities (DPU) for customer generation equipment that will be connected to the Company Distribution EPS on a full or part time basis; see MA SIDG contained in National Grid's Massachusetts and Nantucket electricity tariff, M.D.P.U. 1176 (https://www.nationalgridus.com/masselectric/non_html/rates_tariff.pdf).

3.2 Objectives in the Application Process

1. Parallel operation of a generator becomes a part of the Company Distribution EPS and where the Customer and the Company have a mutual interest the interconnection is required to preserve the safety, reliability, security, power quality, and operational efficiency needs of the Company Distribution EPS. This is necessary to ensure safety to the public and to Company employees and satisfactory operation and compatibility with the electrical supply to others. The steps and timing requirements of the application process are identified within the [MA SIDG](#). Although timing is driven by the SIDG, the time required to complete necessary engineering studies may depend on the characteristics of the generator, the size class (as specified above), its intended operating modes, customer

submittal of technical data and design, and the characteristics of the Company Distribution EPS at the point of interconnection (POI).

2. Additional site-specific requirements may be indicated once the supply voltage, service arrangement, location, and generation purpose is determined, where such purpose can be either:
 - peak shaving*,
 - net energy metering for solar, wind, or agricultural projects as under the Company's net-metering tariff, M.D.P.U. 1177, or
 - export energy for a QF with an agreement for sales** according to the Company's tariff provisions.

** Peak shaving generation is Customer-owned generation operated in parallel with the Company to reduce a Customer's electrical demand. Unlike net metering, peak shaving generation is not permitted to flow into the utility supply system upstream of the billing meter and will require the installation of protection devices. The Company's revenue metering is detented in this case to prevent reverse billing meter registration.*

*** An Agreement for Sales of Export Energy for a QF under a MA SIDG application may be made per the Company's M.D.P.U. 1032-C electricity tariff and is a Power Purchase Agreement.*

3. For new electric service or modifications to electric service to accommodate the Customer's parallel generator, refer to the Company's latest revision of ESB No. 750, Specifications for Electrical Installations. The Customer will be responsible for any permitting and conformance to the latest revision of all local, state and federal codes and national standards that apply. For example, under MA and municipal building code requirements the Customer will need to provide evidence of electrical inspection approval from their local municipal code enforcement agency.
4. When considering a DG interconnection arrangement, an M.D.P.U. 1176 Exhibit A or B application is submitted to the Company's Distributed Generation Services department.
5. Any subsequent sale of an On-Site Generator (OSG) facility covered by the requirements of the MA SIDG of the original retail Customer's facility will require the new owner to establish a separate interconnection agreement (M.D.P.U. 1176 Exhibit F and/or G) for the generation.
6. Refer to:
 - The steps to install distributed generation in Massachusetts as specified in the MA SIDG; see Section 3.0 of M.D.P.U. 1176 (https://www.nationalgridus.com/masselectric/non_html/rates_tariff.pdf),
 - Attached **Exhibit 1** from the Company's electricity tariff, M.D.P.U. 1176 (https://www.nationalgridus.com/masselectric/non_html/rates_tariff.pdf), Figures 1 and 2 and Table 1 application process,
 - Attached **Exhibit 2** for Company requirements for projects not eligible for the Simplified Process,
 - The Company's Technical Sales & Engineering Support (TSES) department's **electronic mail address** as follows for inquiries: Distributed.Generation@nationalgrid.com, and
 - The Company's (www.nationalgridus.com) "Distributed Generation" web site at https://www.nationalgridus.com/masselectric/home/energyeff/3_renewable.asp for information and forms listed below (from M.D.P.U. 1176 https://www.nationalgridus.com/non_html/Interconnect_stds_MA.pdf) when making an application with the Company:
 - Simplified Process application form and service agreement ([Exhibit A](#))
 - Expedited and Standard Process application form ([Exhibit B](#))

- Supplemental Review Agreement (for those projects which have failed one or more screens in the Expedited Process) (Exhibit C)
 - Impact Study Agreement under the Standard Process (Exhibit D)
 - Detailed Study Agreement (for the more detailed study under the Standard Process which requires substantial System Modifications) (Exhibit E)
 - [Schedule Z](#) Additional Information Required for Net Metering service
 - Interconnection Service Agreement (Exhibit F)
 - Agreement between the Company and the Company's Retail Customer (Exhibit G)
- The following Independent System Operator-New England (ISO-NE) requirements apply under this bulletin:
- DG projects 60kW or larger that will export power require asset registration by the Company's TSES department to ISO-NE.
 - DG projects greater than 1 MW but less than 5 MW will require a notification by the Company's TSES department to ISO-NE via Attachment 4 under ISO-NE Planning Procedure (PP) 5-1.
 - DG projects greater than 5 MW will require a review of transmission system impacts and a Proposed Plan Application filed with ISO-NE. Refer to ISO-NE PP 5-1.
7. The application process and attendant services are offered by the Company on a non-discriminatory basis to any customer. As part of the process, the Company may identify the need for detailed engineering studies, distribution system upgrades and additional protection requirements. As allowed by the Massachusetts DPU, the costs of the detailed study and upgrades are the responsibility of the Customer. If the Customer makes significant changes in the design or scheduling of their DG project, then any previous information furnished by the Company to the Customer is subject to review and possible change, which may cause a delay in service.
8. The application process is structured to allow the Customer to review each cost in advance so that the Customer may choose whether or not to continue moving forward with the process prior to committing to these costs. This avoids unnecessary expenditure of resources by either party and is for the benefit of both the Customer and the Company. Where a service upgrade is necessary and is above the base interconnection cost limits in the SIDG, refer to the Company's Terms and Conditions for Electricity Service, M.D.P.U. 1192 (https://www.nationalgridus.com/masselectric/non_html/rates_tariff.pdf) and ESB 750 (https://www.nationalgridus.com/non_html/shared_constr_esb750.pdf).
9. The following website contains the Company's application of the MA SIDG net metering rules: https://www.nationalgridus.com/masselectric/home/energyeff/4_net-mtr.asp.

3.3 Considerations During the Application Process

1. When applying for a DG interconnection within the Company's secondary area network and secondary spot network EPS located in the downtown districts of Brockton, Lynn, and Worcester in Massachusetts, DG installations on distribution secondary network systems may require a study to be undertaken to ensure the DG facility does not degrade the reliability, power quality, safety, or operation of the Company's network system. Therefore, customers in the downtown districts of Brockton, Lynn, and Worcester **should contact the Company's TSES department** (Distributed.Generation@nationalgrid.com) to determine if the proposed location is served by a distribution secondary network system. This should be done while the project is still in the planning stage, and certainly before purchasing equipment or beginning installation. The Company's TSES department will review the Customer's plans and discuss options with the Customer. Refer to attached **Exhibit 3** for area maps locating the Company's secondary network service areas [*to be developed*]. Unlike radial distribution systems that deliver power to each customer in a single path from source to load, underground secondary area network systems deliver power to each

customer through a complex and integrated system of multiple transformers and underground cables that are connected and operate in parallel; refer to attached **Exhibit 4** for more information. The connection of customer DG facilities on networks is an emerging topic, which **(i)** poses some issues for the Company to maintain adequate voltage and worker safety and **(ii)** has the potential to cause the power flow on network feeders to shift (i.e., reverse) causing network protectors within the network grid to trip open. Therefore, to ensure network safety and reliability additional information will be required for the Company's engineering analysis such as:

- Customer's existing* or proposed electric demand profile showing minimum load during peak generation time,
- Customer's expected generation profile shown for a 24-hour period and typical 7-day duration, and
- Customer's complete electric service single-line diagram showing the configuration of the proposed generation and other metered tenants, if any, up to the service point supplied by the Company's secondary network EPS.

** In addition, the Company may need to install recording equipment at all metered electricity users to determine the total demand of the building's network service when obtaining the service connection's electric demand profile. The cost to the Customer will be according to the Company's electric customer load survey flat rate and charged in accordance with the terms of the Company's electricity tariff and MA SIDG.*

2. For more technical information on parallel generator installations, please refer to this bulletin's remaining sections.

3.4 Interconnection Charges

Customers shall be subject to charges for interconnection costs. To permit interconnected operations with a customer, the Company may incur costs. These costs, called interconnection costs, are directly related to the installation of those facilities the Company deems necessary for interconnection. They include initial engineering evaluations, purchase and installation of additional switching, transmission, distribution, and communication equipment at Company's facilities, safety provisions, engineering and administration. These costs shall be paid in full by the Customer prior to commencement of service in accordance with the Company's electricity tariffs, M.D.P.U. 1176 and 1192 and the **MA SIDG**. For typical Company interconnection cost items expected in DG projects that will be defined in either an Impact or a Detailed Study, see the following two tables. Costs will be determined according to the Company's electricity tariff and the MA SIDG.

Table 3.4-1: DG Projects where no EPS upgrades are expected

Item No.	Typical Company Support Activities Attributed to DG Customer's Project
1	Engineering acceptance review of DG Customer's construction design submittals where the Company has mutual interest such as service connection facilities, meter mounting provisions, Company-designated protective devices and control schemes according to the Company's ESB 750 series.
2	Revenue metering equipment changes/additions.
3	Field audit of DG Customer installation to accepted design.
4	Field compliance verification - witness tests of DG Customer protective devices coordinating with the Company Distribution EPS.
5	TSES Project Management

Table 3.4-2: Complex DG Projects

Item No.	Typical Company Support Activities Attributed to DG Customer's Project
1	Company Distribution EPS upgrades (e.g., Current Limiting Fuses, Primary Conductors, Line Reclosers, Switches, Voltage Regulators, Capacitors, etc.) as a result of DG impact.
2	Where Local EPS anti-islanding protection is required, DTT transmit addition to Distribution EPS substation feeder breaker (and/or Line Recloser) for DG impact on distribution feeder.

Item No.	Typical Company Support Activities Attributed to DG Customer's Project
3	Where Company-provided Radio Communications can be applied, additions to support DTT equipment at Distribution EPS substation feeder breaker (and/or Line Recloser) for DG impact on distribution feeder.
4	Where Local EPS feeder selectivity may require prompt control measures for DG impact on distribution feeder operations, EMS-RTU (status & control) addition at the DG facility.
5	Service Connection modifications and additions for DG impact on the Company Distribution EPS.
6	Revenue metering equipment changes/additions.
7	Engineering acceptance review of DG Customer's construction design submittals where the Company has mutual interest such as service connection facilities, meter mounting provisions, Company-designated protective devices and control schemes (e.g., DTT receive package installation at DG) according to the Company's ESB 750 series.
8	Field audit of DG Customer installation to accepted design.
9	Field compliance verification - witness tests of DG Customer protective devices coordinating with the Company Distribution EPS.
10	Project Management (TSES, Distr. Line, Distr. Station, etc.)

4.0 Overview of Potential Issues Related to Interconnection

1. Customer generation connected to the distribution system can cause a variety of system impacts including steady state and transient voltage changes, harmonic distortion, and increased fault current levels. Parallel generation systems, which located individually on higher capacity feeders may not cause very serious impacts, can, on weaker circuits, in aggregation or in special cases (such as lightly loaded networks), significantly impact the Company's Distribution EPS.
2. An Impact Study and a Detailed Study in some cases is needed to identify the severity of system impacts and the upgrades needed to avoid problems on the Company Distribution EPS. Typically, an Impact or Detailed Study will be performed by the utility to determine if the proposed generation on the circuit results in any relay coordination, fault current, and/or voltage regulation problems.
3. There is a wide range of potential issues associated with the interconnection of DG facilities to the Company Distribution EPS including, but not limited to:
 - Impact on step voltage regulation equipment
 - Increased fault duty on Company circuit breakers
 - Interference with the operation of protection systems
 - Harmonic distortion contributions
 - Voltage flicker
 - Ground fault overvoltages
 - Islanding
 - System restoration
 - Power system stability
 - System reinforcement
 - Metering
4. It is important to scrutinize the interconnection of Customer DG facilities to the Company Distribution EPS so that any negative impacts can be avoided and assure that the customer generation will have only a positive or, at least, neutral impact on the EPS performance. It is the intent of any Company study in accordance with SIDG requirements when applicable to avoid negative power system impacts by identifying the particular type of impact that will occur and determining the required equipment upgrades that can be installed to mitigate the issue(s).
5. Anywhere within the Company's service territory that where customers plan to interconnect generation, they will be interfacing to one of two main types of distribution systems. These will be either radial systems or network systems. The interface voltage levels will be either low voltage (less than 600 volts) or medium voltage (greater than 600 volts and less than 15,000 volts) depending on the location on the Company's system and size of the generator.

6. In general, DG facilities connected to various locations on the **radial distribution EPS** are limited as listed in the below Table 4.6-1. This table provides an upper limit that represents the maximum possible DG capacity under ideal situations and assumes that on the Company Distribution EPS there are no additional limitations as indicated by site specific system studies (e.g., available short circuit current contributions, minimum network loading in light loading seasons, voltage regulator interactions, etc.). When a DG facility (or aggregate DG facilities) on a feeder or local EPS of a feeder is above the limits in Table 4.6-1, these warrant further study by the Company to determine feasibility and remedial action.

Illustration 4.6-1: Typical DG Installation Areas on Radial Distribution Feeders

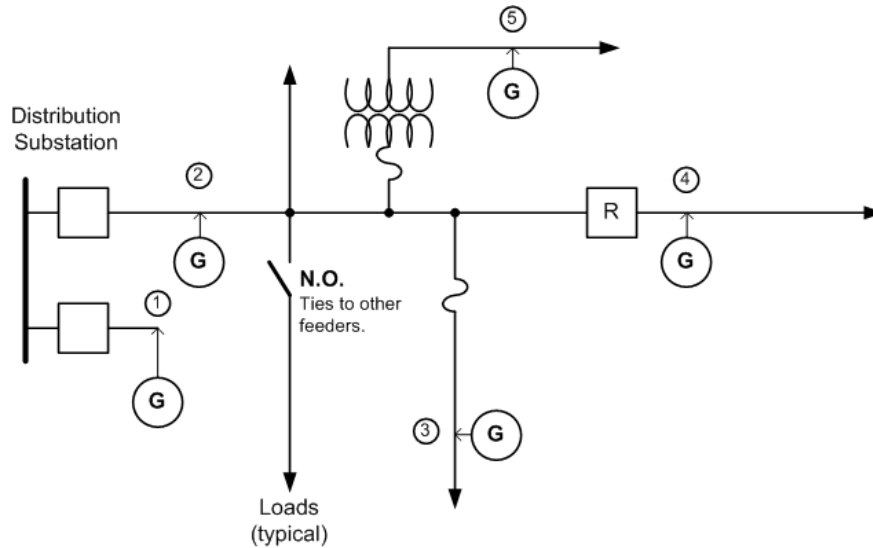

“O” - DG Interconnection Location Point on Feeder

1. Express (dedicated) radial feeder
2. Feeder Main
3. Feeder Branch protected by fuse
4. Sectionalized Feeder Main
5. Feeder Branch protected by fuse with ratio transformer

Table 4.6-1: Typical Planning Limits for DG Connection to Radial Distribution Feeder

Typical Gross Generation Capacity Limit (see notes below)		
DG Location on Feeder	3-phase Radial Distribution Voltage Class System	
	4 or 5kV	15kV
1. Express (dedicated) Radial Feeder	2.8MVA	9.0MVA
2. Feeder Main	0.75MVA	2.5MVA
3. Feeder Branch protected by Fuse	75kVA	250kVA
4. Sectionalized Feeder Main	100kVA	300kVA
5. Feeder Branch protected by Fuse with Ratio Transformer	50kVA	150kVA

Notes to Table 4.6-1:

- a. *These generation capacities are on a per-generator basis on full nameplate ratings and at unity power factor. It should be noted, however, that the aggregate generation (sum of the total gross generation of all DG systems connected to a particular segment of the Company’s system) is considered for all points along the distribution feeder. The Company will evaluate each application before deciding on the maximum MVA allowed onto the Company’s system at a given point.*
- b. *Limits apply to synchronous and induction rotating generator machines. The DG facility shall maintain power factor at the PCC in accordance with the MA SIDG; at 0.90 Power Factor leading or lagging (for Var or voltage support can also be considered within machine ratings). See ESB 750 regarding disturbances and capacitor installation.*

- Exceed the ampacity rating of any service facility.
- Create an unbalanced loading condition between phases of a service.

The interconnection of multiple services above 600 volts shall be specified by the Company within the Company's operating practices and electric service requirements to ensure safety to the public, to Company employees, and to the Customer.

5.0 General Design and Operating Requirements

From the perspective of interconnection, there are three main types of customer generation systems that interface to the Company's Distribution EPS. These include:

- Induction Generators
- Static Power Converters (inverter-based)
- Synchronous Generators

Each type has its own specific characteristics regarding synchronization equipment, protective functions, starting practices, and electrical operating behavior. There may also be additional specific requirements that may be identified as part of any Impact or Detailed Study that is performed for a specific location.

5.1 Applicable Codes, Standards, and Guidelines

1. The Customer's DG facility shall conform to the latest revision of all local, state and federal codes and national standards that apply. Specific standards applicable to this bulletin include, but are not limited to:
 - Institute of Electrical and Electronics Engineers (IEEE) Std. 1547 "Standard for Distributed Resources Interconnected with Electric Power Systems"
 - Underwriters Laboratories (UL) Std. 1741 "Inverters, Converters and Charge Controllers for Use in Independent Power Systems"
 - NFPA 70 "National Electrical Code" (NEC)
 - NFPA 70B "Recommended Practice for Electrical Equipment Maintenance"
 - NFPA 70E "Standard for Electrical Safety in the Workplace"
 - NETA-MTS "Maintenance Testing Specifications for Electrical Power Distribution Equipment and Systems"
2. The Customer's DG facility shall also conform to any applicable requirements of the Massachusetts DPU and any local, state, federal and/or other agencies from which a review, approval, or a permit is required.
 - The minimum "fall zone" clearance of wind turbine generators (WTG) shall be in accordance with the local governmental authority having jurisdiction (AHJ) and in any case, shall not be less than 125% of maximum WTG height measured horizontally to the Company's overhead distribution lines.
3. The Customer shall comply with the appropriate Company ESB or tariff requirements, which cover details for the Customer's electric service installation. These include:
 - **ESB 750** - Specifications for Electrical Installations
 - **ESB 751** - General Requirements Above 600-volt Service (*under development*)
 - **ESB 752** - Service Above 15,000 volts
 - **ESB 753** - Primary Meter Pole
 - **ESB 754** - Outdoor Pad Mounted or Vault Enclosed Single and Three Phase Transformer
 - **ESB 758** - Primary Service to Metal Enclosed Gear
 - **M.P.D.U. 1176** - Massachusetts Electric Company Nantucket Electric Company d/b/a National Grid Standards for Interconnecting Distributed Generation (MA SIDG)

- **M.D.P.U. 1192** - Massachusetts Electric Company Nantucket Electric Company Terms and Conditions for Distribution Service

Refer to **Exhibits 5** and **6** and **Figures 1** through **4** for information when submitting single-line diagrams to the Company's TSES department (electronic mail address: Distributed.Generation@nationalgrid.com).

5.2 Definitions

See the **MA SIDG** for definitions of special terms.

5.3 General Criteria

The interconnection of all parallel generators requires safeguards for synchronization and back feed situations in accordance with the MA SIDG. Each specific connection must be studied with respect to size, type, and the nature of the Company's Distribution EPS at the POI. Only the results of a specific study can indicate the suitability of a given generator connection to the Company's Distribution EPS and its possible economic viability. See the **MA SIDG** for detailed requirements.

5.3.1 Single Phase

Single phase parallel generator connections to Company Distribution EPS circuits under 600 volts present power quality and phase balance challenges. Single phase connections shall have these minimum characteristics:

- Nameplate rating of a single generator or group of generators equal to or less than 50kVA (see Note "e" to Table 4.6-1).
- Configured as a three-wire, line-to-line with neutral, or line-to-neutral with adequate load balance.
- A dedicated service lateral with a dedicated transformer, when required by the Company.

5.3.2 Three Phase

Three phase connections are required in all other instances.

5.3.3 Phase Balance

The Customer's DG facility shall permit equal current in each phase conductor at the service point. Voltage unbalance resulting from unbalanced currents shall not exceed 2% and shall not cause objectionable effects upon or interfere with the operation of the Company's facilities and service to others. This criterion shall be met with and without generation.

5.3.4 Neutral Stabilization and Grounding

Where the Customer is served from a Company four-wire multi-grounded neutral distribution circuit, adequate grounding must be provided to ensure neutral stability during accidental isolation of the line from the main system. This may require an additional ground source. Adequate grounding can be provided either by the use of wye-delta main power transformer (see Section 5.5) or by installing an appropriate grounding transformer. The effects of such grounding on the Company's ground-relay sensitivity shall be limited.

As a minimum, the Customer's generation equipment shall be grounded in accordance with the latest requirements of the National Electrical Code (NEC). For specific installations, refer to the applicable sections of this document and the Company's ESB 750. The Company requires ground protection on any system that can be a generation source and to protect transformers that can be paralleled and supplied from two sources. When generator tripping is needed to sense ground faults on the Company's Distribution EPS:

- The winding arrangement of the Customer's DG facility transformer shall be such that the Company's system remains effectively grounded (see Section 5.5.3).

- The Company may require that the grounding impedance be limited to the highest value suitable for neutral stabilization (see Section 5.7.2), or to limit generator ground fault contributions (see Section 5.7.5).
- A “zero-sequence” voltage or “3V₀” or “GV3” scheme will be required on the primary side of a delta primary wound transformer supplying the DG facility; see **Figure 4**.

5.4 Service Equipment and Revenue Metering

5.4.1 Service Equipment Requirements

1. The Customer shall provide service entrance equipment as a part of their installation; see the Company’s ESB 750. The Customer’s service equipment shall be rated, at a minimum, for the maximum fault current available from the Company Distribution EPS and their own contribution from the generator(s), motors, etc.
2. At the service entrance equipment, the Customer shall have a permanent directory plaque to indicate all electric sources and the Generator Disconnect location(s) on their premise according to the NEC.
3. For large DG Customers with generation systems equal to or greater than 500kW, refer to the typical primary overhead service configuration requirements in **Exhibit 7**.

5.4.2 Company Revenue Metering Requirements

1. The Company will specify the location and arrangement of all equipment required for the revenue metering of the Customer’s service and DG facility. Reference the Company’s ESB 750, Section 7 for additional information and requirements. The Company’s electricity tariff, M.D.P.U. 1177, describes qualifications for net metering.
2. An analog/POTS (Plain Old Telephone Service) telecommunications line to each Company-owned revenue meter location shall be provided by the Customer. The telephone line shall be capable of direct inward dial without human intervention or interference from other devices such as fax machines, etc.

5.5 Transformer

5.5.1 Purpose for DG Facility Interconnecting Transformer

A transformer at a DG facility serves three purposes. First, it enables proper voltage matching between the generator and the utility connection. Second, it acts as a buffer to limit any current contribution from the DG facility in the event of a short circuit on the electric system. Third, it can ensure effective grounding of the utility circuit when the DG is exporting power.

5.5.2 Secondary Served DG Customers

Where the Company provides secondary service, the Company’s transformer is an equipment standard for service delivery voltages; see Section 3 in **ESB 750**. Non-standard transformers are not provided by the Company. The Company will determine when dedicated services and a dedicated transformer are required in order to reduce the impact on other adjacent customers. The need for a dedicated transformer(s) may be determined at any point in the generator’s life cycle. If a dedicated transformer(s) is required, the Customer will be advised by the Company in writing. The cost of the transformer(s) will be the responsibility of the Customer according to M.D.P.U. 1192 and as permitted by the **MA SIDG**. DG projects need to be aware that the distribution EPS at rural locations will have single-phase loads on the feeders where phase impedance is typically unbalanced.

5.5.3 Primary and Higher Voltage Served DG Customers

The Company reserves the right to specify the winding connections for the Customer’s “step-up” transformer between the Company’s delivery point and the Customer’s DG facility’s output voltage as well as whether it is to be grounded or ungrounded. The Customer shall provide their interface “step-up” transformer’s specifications and ratings for the Company’s review in the impact and detailed studies.

5.5.3.1 Effectively Grounded, Four-wire Multi-grounded 3-phase Wye EPS:

The Company requires that all interface transformers be configured to have a wye connected primary winding with a fully insulated neutral, and the secondary winding to have a delta connection.

- If infeasible, an alternative that is subject to Company acceptance review is a primary wye grounded - secondary wye grounded transformer requiring a grounded source permitted under specified conditions.
- Any DG or aggregate DG below 500kW in a Customer's facility may be permitted to utilize a primary delta - secondary wye grounded transformer.
- Where any DG or aggregate DG is 500kW or greater in a Customer's facility, ungrounded transformers (i.e. primary delta or Yg-Yg with ungrounded source) are not permitted on any Company-owned effectively grounded, four-wire multi-grounded 3-phase wye circuits.

5.5.3.2 Not Effectively Grounded, Three-wire 3-phase EPS:

The Company only allows the connection of delta primary interface transformers on three-wire not effectively grounded 3-phase primary and high voltage circuits. Refer to Section 5.3.4 for grounding requirements such that the generator does not contribute to line-ground faults on the Company's EPS.

5.6 Manual Generator Disconnect Switch

1. According to the **MA SIDG**, inverter-based systems 25 kW and below are not required to have a separate disconnect if the unit has a disconnecting means integrated into the design and meets the requirements of the National Electrical Code (NEC).
2. For those projects requiring a disconnect switch (or comparable device mutually agreed upon by the Company and the Customer) at the point of DG facility interconnection that can be opened for isolation, these isolation devices shall be rated to interrupt the maximum generator output; meet applicable Underwriters Laboratories (UL), American National Standards Institute (ANSI), and IEEE standards; and shall be installed to meet the NEC and all applicable local, state, and federal codes.
3. The Customer's DG facility shall have an electrical load break disconnect switch accessible at all times to the Company to electrically isolate the Company's Distribution EPS from the Customer's generator facilities.
4. In accordance with the Company's safety rules and practices, this isolation device must be used to establish a visually open, working clearance boundary when performing maintenance and repair work. The designated generator disconnect also must be accessible and lockable in the open position and have provisions for both Company and Customer padlocks and be capable of being tagged and grounded on the Company side by Company personnel.
5. The visible generator disconnect switch shall be a gang-operated, blade-type switch (knife switch) meeting the requirements of the NEC and nationally recognized product standards. Pull-out switches commonly used in air-conditioning units and spas are not permitted for this application. The visible break requirement can be met by opening the enclosure to observe the contact separation. The Company shall exercise such right in accordance with Section 7.0 of the **MA SIDG**.
6. The connection of the disconnect switch shall have the line connection (i.e., jaw side) of the switch made to the utility source.
7. Additionally, the Customer is solely responsible for the maintenance of all fuses in fused, blade-type disconnect switches.
8. This disconnect device shall be identified by a permanent sign as required by the NEC and the **MA SIDG**.

9. For 4 or 5 or 15kV class interconnections, the DG Customer shall use a lockable, 15kV, 3-phase, gang-operated disconnect switch at the PCC. The DG Customer shall provide the Company with 24-hour/7-day unlimited access and control of this isolation switch.

5.7 Protective Device Equipment

5.7.1 Protection Requirements

All DG facilities shall meet performance requirements set forth by Section 4.2.3 in the MA SIDG. DG types of interconnection are categorized as either Group 1 “Facilities Qualified for Simplified Interconnection” or Group 2 “All Facilities Not Qualified for Simplified Interconnection” according to the **MA SIDG**. The Under Frequency relays for the Group 2 DG facilities shall not trip at frequencies higher than the curve provided for the “Eastern Interconnection Generator Tripping” in Figure 1 of the PRC-006-NPCC-1 Automatic Underfrequency Load Shedding criteria specified in the **MA SIDG**.

The DG Customer's interconnection system shall have the capability to withstand voltage and current surges in accordance with the environments defined in the latest IEEE Standard C62.41.2 or IEEE Standard C37.90.1 as applicable.

5.7.2 Interconnection Interrupting Device

An interconnection interrupting device such as a circuit breaker shall be installed on the high voltage side of the interface transformer to isolate the DG facility from the Company's EPS. If there is more than one interrupting device, this requirement applies to each one individually. The interconnection interrupting device shall be capable of interrupting the current produced when the DG facility is connected out of phase with the Company's EPS.

5.7.3 Interconnection Transformer Configuration

In order to avoid Over Voltage (OV) on the distribution customers, it is National Grid's policy that any Distributed Generator equal or above 500kW connected to a four wire distribution feeder should provide an effectively grounded system with respect to the Company's EPS; see Sections 5.3.4 and 5.5 for grounding and transformer requirements. Contributing to the faults on the Company's four-wire distribution EPS can desensitize the relays at the Company's substation. Hence, it is required that the DG Customer provide a fully insulated neutral bushing for the primary wye winding of the step-up transformer and install a fault current limiting grounding reactor to limit the fault current to 3 times the generator rating. The grounding reactor shall not violate the effectively grounded system requirements. The inductive value of the reactor will be specified by the Company.

5.7.4 Instrument Transformers for Protective Device Relays

5.7.4.1 Current Transformers (“CT”)

CT ratios and accuracy classes shall be chosen such that secondary current is less than 5 amperes normal operation, 100 amperes under maximum fault condition and transformation errors are consistent with Company practices.

5.7.4.2 Voltage Transformers (“VT”) and Connections

See Sections 5.3.4 and 5.5 for transformer requirements. The DG facility shall be equipped with a direct voltage connection or a VT, connected in accordance with the Company's requirements. The DG Customer is responsible for over voltage detection and the detection of line-to-ground faults on the primary and secondary sides of the step-up transformer as well as the Company's EPS. For wye reactively grounded primary, delta secondary transformers, the DG Customer is required to install Yg-Yg VTs on their transformer secondary delta winding which will have the dual purpose to detect the voltage depression on the faulted phase on low voltage line-to-ground faults to enable the operation of the 51C controlled overcurrent elements when faults occur on the Company EPS, as well as, detect the over voltage on the unfaulted phases for single phase-to-

ground faults on the delta side of the step-up transformer. The use of Yg-Open Delta VTs will be considered by the Company on a case-by-case basis.

5.7.5 Synchronizing Devices

The DG Customer shall designate one or more Synchronizing Devices such as motorized breakers, contactor/breaker combinations, or a fused contactor (if mutually agreeable) to be used to connect the DG facility's generator to the Company's EPS. This Synchronizing Device could be a device other than the Interconnection Interrupting Device. The Synchronizing Device must be capable of interrupting the current produced when the Facility is connected out of phase with the Company's EPS.

5.7.6 Voltage Relays

Voltage relays shall be frequency compensated to provide a uniform response in the range of 40 to 70 Hz.

See Sections 5.3.4 and 5.5 where the DG Customer needs to install Yg/Yg instrument voltage transformers (VT) on their transformer secondary delta winding to detect overvoltage on unfaulted phases caused by single line-to-ground faults and provide voltage detection for a voltage controlled overcurrent (51C) element, which will trip the high side interrupting device.

5.7.7 Frequency Relays

Over and Under Frequency relays shall meet IEEE 1547 requirements. In addition, Group 2 DG facilities shall not be set above the "Eastern Interconnection Generator Tripping" curve of Figure 1 "Thresholds for Setting Underfrequency Trip Protection for Generators" in PRC-006-NPCC-1 "Automatic Underfrequency Load Shedding" criteria specified in the [MA SIDG](#).

5.7.8 Overcurrent Relays

See Sections 5.3.4 and 5.5 for transformer requirements. Overcurrent protection is required on the high side of the DG Customer's interface transformer to detect faults on the Company's EPS. Voltage controlled overcurrent elements (51C) are required for both phase and ground. These relays shall utilize voltage sensing via the Yg-Yg VTs on the DG Customer's transformer secondary delta winding to detect the single line-to-ground faults. The 51C elements shall trip the high side interrupting device.

5.7.9 Type Tested Equipment

Protective equipment that has been type tested and recognized under UL Standard 1741.1 by the [MA SIDG](#) for Group 1 DG facilities will be permitted. The Customer shall follow the testing requirements as outlined in the MA SIDG. **Exhibit 8** attached is a guide for the Company's witness for verifying a type tested net-metered DG installation's operational compliance.

5.7.10 Non-Type Tested Equipment

Protective equipment that has not been type tested per the [MA SIDG](#) and considered as Group 2 DG facilities will be permitted with the implementation of utility grade protective devices acceptable to the Company. The use of utility grade relays and relay redundancy is acceptable subject to prior Company review and acceptance. It is the Company's policy that any DG equal or above 500kW requires redundant relaying. At the Company's discretion the Company reserves the right to require redundant utility grade relays for systems 250kW and above. The relay specifications are classified as follows:

5.7.10.1 Photovoltaic (PV) Generation

IEEE 1547 compliant and UL-1741 certified inverters shall be equipped with an internal anti islanding scheme and active under voltage (27), over voltage (59), zero sequence over voltage (59N), under frequency (81U) and over frequency (81O) relays.

5.7.10.1.1 Inverter-based PV Generator Equal or Above 500kW

The internal relays are considered as primary protection and the Company requires one additional utility grade relay to be installed as the secondary protection if the inverter-based PV size is equal or above 500kW. The 27, 59, 59N, 81U/O and voltage controlled over current 51C (Phase and Ground) elements shall be activated in the redundant relay. The utility grade relay failure alarm shall be wired to the Company-designated generator interrupting device. If the step-up transformer configuration is primary wye grounded - secondary delta, the over voltage element (59N) shall have the capability of detecting the Line-Ground faults on the delta side and trip the high side (utility side) interrupting device to separate the Company's EPS from the Line-Ground faults on the delta side (customer side) of the step-up transformer.

5.7.10.1.2 Inverter-based PV Generator Below 500kW

If the inverter is IEEE 1547 compliant and UL-1741 listed, the internal relays are considered as the only required protection and an additional utility grade relay is not necessary to be installed.

5.7.10.2 All Other Parallel Generation Equal or Above 500kW

For any generator equal or above 500kW, if the generator is equipped with internal relays with 27, 59, 59N and 81U/O relays, one utility grade relay is required to be installed as the secondary protection. Otherwise, two utility grade relays and one Company-designated interrupting device shall be installed to meet the protection requirements. The relay tripping scheme for the non-PV generators is the same as that of the inverter-based PV type.

5.7.10.3 Protective Relay Hard-Wire Requirement

Unless authorized otherwise by the Company, protective relays shall be hardwired to the device they are tripping. Further, interposing computer or programmable logic controller or the like is not permitted in the trip chain between the relay and the device being tripped.

The interconnecting relay shall be hardwired to the interconnecting interrupting device at the point of interconnection. There shall be no interposing programmable logic controller in the trip circuit.

Meter selector switches shall not be connected into the secondary circuits of current transformers used with protective relays specified by the Company.

5.7.10.4 Interconnection Interrupter Tripping and Protective Relay Supply

Interconnection interrupting devices shall have DC trip coils and tripping energy shall be derived from station batteries. Battery voltage, capacity specifications, and charging system provisions are subject to approval by the Company.

Control circuits associated with protective relays shall be DC powered from a battery and battery charger system. The battery shall be the sole source of tripping energy. Solid state relays shall be self-powered or DC powered from a battery and battery charger system.

If the DG facility uses a Company approved non-latching interconnection contactor, AC powered relaying may be permitted provided the relay as well as its method of application are fail-safe, meaning that if the relay fails or if the voltage and/or frequency of its AC power source deviate from the relay's design requirements for power, the relay or a separate fail-safe power monitoring relay acceptable to the Company will immediately trip the generator by opening the coil circuit of the interconnection contactor.

5.7.10.5 Use of Microprocessor Based Relays

1. Number of Relays Required:

Where relay performance may affect the operation of the Company's Distribution EPS at service voltages less than 15kV, a single microprocessor-based relay

along with a Company approved scheme, where relay failure automatically trips the associated breaker(s), is acceptable. If the Customer decides not to use redundant microprocessor based protection systems on their other equipment, then appropriate action such as removing equipment from service shall be taken when a piece of equipment is no longer adequately protected.

2. Test Switches:

Microprocessor relays shall have ABB FT-1, or equivalent, test switches isolating all inputs and outputs of the relay.

Each relay designated by the Company as necessary to protect its electric system shall have its own test switch for AC and DC inputs that are associated with, and only with, that relay. DC test blades isolate the positive and negative DC for each input and output.

5.7.11 Utility Grade Protective Device Settings and Verification

5.7.11.1 Company-designated Relays and Customer Settings

The Company will review the Customer's settings and their calibration and test results of those relays that the Company's engineering department designates as being required to satisfy the Company protection practices. Any relay setting specified by the Company shall not be changed or modified at any time without the written consent of the Company.

5.7.11.2 Company Verification of Relay Testing

The Company requires a letter from the Customer stipulating that all Company-designated protective devices shall have:

- control wiring verified against the accepted design drawings, and,
- the calibration test performed satisfactorily according to the relay setting document of the accepted design.

The Company reserves the right to witness the Customer's functional test of the required devices, i.e., trip tests. This activity will normally be performed on a schedule as specified by Section 4.2.4 in the **MA SIDG**.

The Customer shall be responsible to specify the settings, calibrate, test, and maintain the balance of their equipment.

5.7.12 Anti-islanding

The Customer's generation facility will not be permitted to energize a de-energized Company circuit. The IEEE 1547 states that anti-islanding protection is required for parallel generation on the EPS. The Customer may propose various methods of anti-islanding protection of their own generation facility. It is the Customer's responsibility to demonstrate comprehensively the validity of such methods and the Company reserves the right to make the final determination as to which anti-islanding protection method is suitable. The use of direct transfer trip (DTT) is a definitive protection means for anti-islanding protection under good utility practice. Due to normal operation of Company switches, circuit breakers, and reclosers, the Customer's DG facility may be islanded with only a portion of the total feeder load. The Company evaluates anti-islanding protection for minimum load on the entire feeder and on the smallest switched feeder segment that may be connected to the DG.

Note: A Customer wishing to use a generation system as a stand-by or emergency generator shall submit details regarding an interlocking scheme, or transfer switch to prevent the energization of a de-energized Company circuit that complies with National Grid ESB 750, Section 11.

Direct Transfer Trip (DTT) may be specified for the following conditions:

5.7.12.1 Inverter-based Photovoltaic (PV) Generation

Relays at the Customer's DG facility and the Company's substation should be capable of detecting all four types of faults in the EPS. There may be conditions

where intentional opening of the substation feeder breaker/recloser or in-line reclosers could cause the Customer's DG to island where the DG facility continues energizing the islanded feeder for more than 2 seconds. Those conditions can be classified as follows:

5.7.12.1.1 Load and Generation Match and Reactive Power Source in the Feeder Greater than 33% Generation

If there is a chance that minimum load on the feeder is close to the maximum generation such that the system frequency of the islanded feeder falls within acceptable range and the amount of reactive power being generated by the feeder capacitor banks in the islanded section of the feeder is above 33% of the inverter-based PV generation nameplate rating, there is a chance that the PV may create an island. Further transient analyses for dynamic conditions are required to determine the PV DG system's run-on time. In this case, DTT will be required to shut down the generator system in less than 2 seconds once the island forms. DTT may also be required for run-on time less than 2 seconds, if the analysis shows that damaging over-voltages could occur during that period.

5.7.12.1.2 Multiple Generators Containing PV on EPS

If the inverter-based PV generation is connected to a feeder that is already connected to reciprocating generators and the aggregate size of the reciprocating (i.e. synchronous or induction) generators is larger than 20% of the PV rating, a transient analysis for dynamic conditions is required to determine whether or not the island will form. The reciprocating generator can deactivate the inverter's anti-islanding scheme by tending to decelerate the rate of change of frequency due to the rotor inertia and absorbing reactive power for self excitation. The reactive power being injected by the inverters to perturb the frequency and detect the islanding condition may not be sufficient in the presence of the reciprocating generators.

5.7.12.2 All Other Parallel Generation Except PV Generators

If the minimum load on the feeder is above 3 times the maximum generation, DTT is not required. Otherwise, a transient analysis for dynamic conditions and a protective device coordination study are required to determine whether or not the islanding condition can form.

5.7.12.3 High-Speed Protection

The DG facility may be required to use high-speed protection if time-delayed protection would result in degradation in the existing sensitivity or speed of the protection systems on the Company's EPS.

5.7.12.4 DTT Installation Requirements

When DTT is specified for a parallel generation project, the Company will determine the requirements for equipment, installation, and communications media in the interconnection study. The communication option selected in the interconnection study must be agreed upon by all parties. The DG Customer shall bear the responsibility for cost and securing equipment on their property and contribute to the associated costs, including any recurring costs, for the Company's equipment in accordance with the applicable Company tariff.

5.7.13 Power Quality Compliance Verification

If during the study a DG interconnection project is identified as having the potential to cause power quality (PQ) effects on the EPS, then PQ monitoring shall be installed by the Company or Company-accepted third party PQ testing company to verify power quality with and without generation. Third party PQ test methods and results may be submitted to the Company for review and acceptance. These verification tests shall

include, at a minimum, the following in accordance with the Company's electricity tariff, M.D.P.U. 1192 and the limits and cost responsibilities specified in the **MA SIDG**:

- Check service point voltage for any discernible voltage fluctuation.
- Check service point frequency for any discernible frequency fluctuation.
- Check service point power factor to ensure it is no less than 90% (leading or lagging).
- Check service point harmonic distortion to ensure limits specified in ESB 750 and the MA SIDG as applicable, are maintained. Current harmonic distortion shall not adversely affect voltage harmonic distortion, the Company Distribution EPS, or service to other customers.

6.0 OPERATING

6.1 Power Factor

The Customer's overall (leading or lagging) power factor at the service point shall not be less than 90% or that which is permitted at the PCC by the **MA SIDG**. Corrective equipment may be required; if so, refer to ESB 750.

6.2 Power Quality Monitoring

1. If disturbances on the EPS and/or to other customers are determined to originate from a Customer with DG, PQ monitoring shall be installed to verify power quality in accordance with the Company's electricity tariff, M.D.P.U. 1192.
2. **If any power quality concerns cannot be corrected, the Customer will not be permitted to continue generation until such concerns are resolved to the Company's satisfaction.**

6.3 Isolation

Pursuant to Section 7 in the **MA SIDG**, the Company reserves the right to have the Customer remove their generation from the Company Distribution EPS at any time upon the Company's request. Normally, such requests result from the need to facilitate maintenance, test, or repair of Company facilities. The Customer's generator disconnect switch may be opened by the Company (i.e., isolating the Customer's generating equipment), without prior notice to the Customer, for any of the following reasons:

- System emergency operations require such action.
- Company periodic checks of Customer's interfacing equipment reveal a hazardous condition.
- Generating equipment interferes with other customers or with the operation of the Company Distribution EPS.
- Protective device tampering.
- Parallel operation, other than for **MA SIDG** testing of type tested inverters, prior to Company approval to interconnect.
- Failure to make available records of verification tests and maintenance of the Customer's protective devices designated by the Company.

6.4 Energy Management System-Remote Terminal Unit (EMS-RTU)

For distributed generator (DG) facilities,

- Less than 1MW, if there is feeder selectivity operation, then the Company may require an EMS-RTU.
- 1MW or greater, the Company requires an EMS-RTU for status and control of the generator.

The required inputs from the RTU to the Company's EMS are as follows:

- Status of individual generator breakers

- Status of main or interconnect breaker at the point of common coupling (PCC)
- Three phase line current for each generator
- Three phase line current at the PCC with the Company
- Three phase line-to-line voltage for each generator
- Three phase line-to-line voltage at the PCC with the Company
- Output kW for each unit (+ delivered to the Company, - received)
- Output kVAR for each unit (+ delivered to the Company, - received)
- Total MW (+ delivered, - received) at the PCC
- Total MVAR (+ delivered, - received) at the PCC

Exceptions to the above list may be considered by the Company on a case-by-case basis.

Note: The Company will provide an EMS-RTU point list for inputs required at the DG facility.

The control portion would only involve the remote trip and block closing of the Customer's automated disconnect device designated by the Company. The block close function will be performed by control circuitry and is subject to Company acceptance review.

When a Company EMS-RTU is specified for a parallel generation project, the Company will determine the requirements for equipment, installation, and communications media in the interconnection study for the DG facility. The DG Customer will be responsible for all initial and recurring costs associated with MPLS communications for their RTU.

6.5 Balance of Customer Equipment

1. The Customer is responsible for performing all operating functions associated with their equipment and for maintaining all equipment under their ownership. The Customer shall arrange to have trained personnel available for the proper and safe operation of their equipment.
2. The Customer shall provide proper and continuous maintenance of all plant facilities; refer to National Fire Protection Association (NFPA) recommended practice NFPA 70B (and NFPA 73 where applicable) and other nationally recognized industry guides for guidance on electric equipment maintenance. See also the Company's ESB 755.
3. Where the Company is requested to supply demand pulse information (either analog or digital), its use is not intended for generator control.

7.0 REVISION HISTORY

<u>Version</u>	<u>Date</u>	<u>Description of Revision</u>
1.0	06/01/07	Initial version of new document superseding all previous revisions of ESB 756.
1.1	07/29/11	September 2010 ESB 750 Series Errata changes, formatting, and general editing.
2.0	05/11/12	Revised and formatted incorporating technical requirements of MA DPU 1176 Dec. 2009.

EXHIBITS ATTACHED

EXHIBIT 1: M.D.P.U. 1176 Tariff

https://www.nationalgridus.com/masselectric/non_html/rates_tariff.pdf

Figure 1 – Schematic of Massachusetts DG Interconnection Process

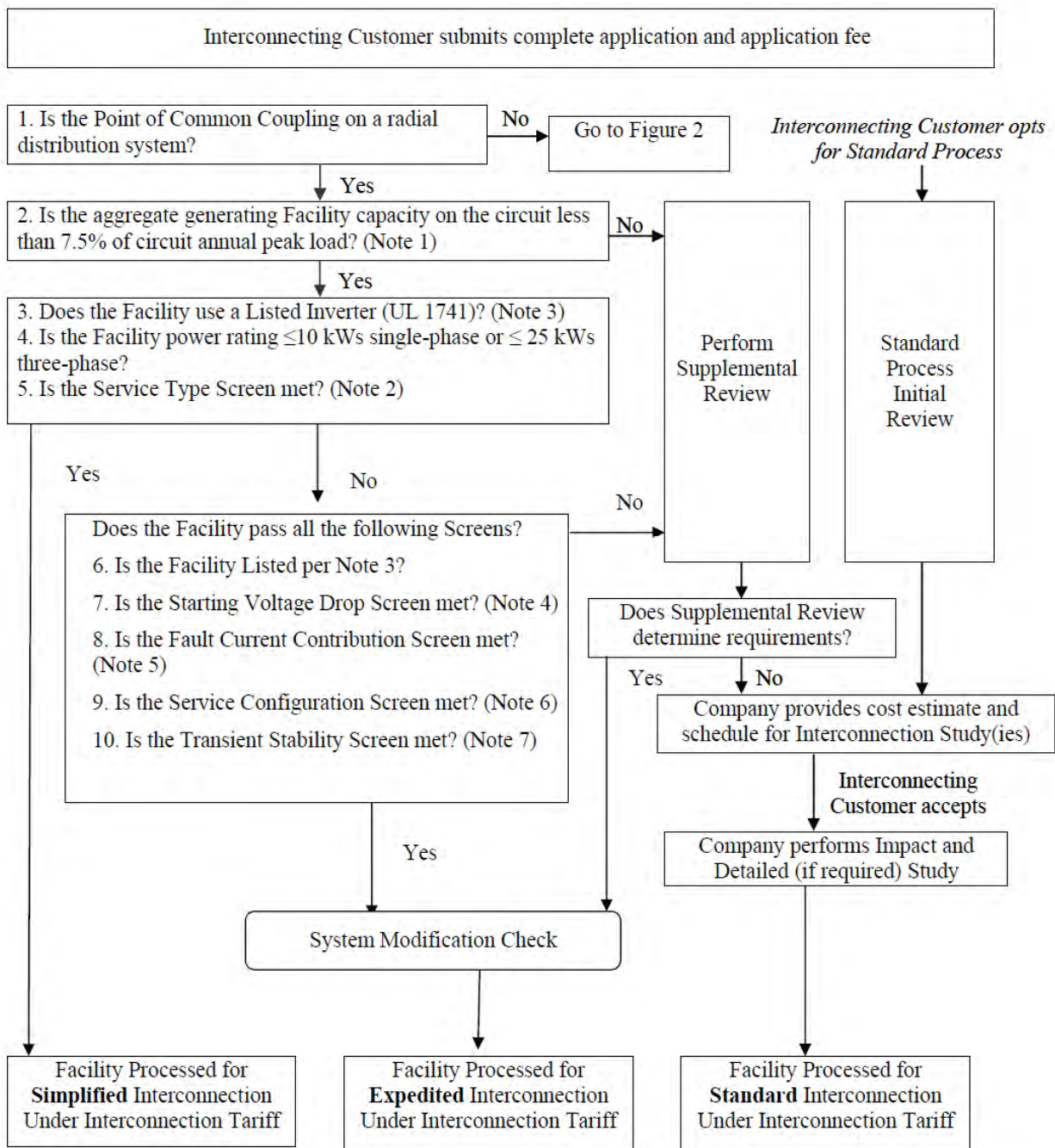

For explanatory notes accompanying Figure 1, see M.D.P.U. 1176, sheet 17.

Figure 2 – Simplified Interconnection to Networks

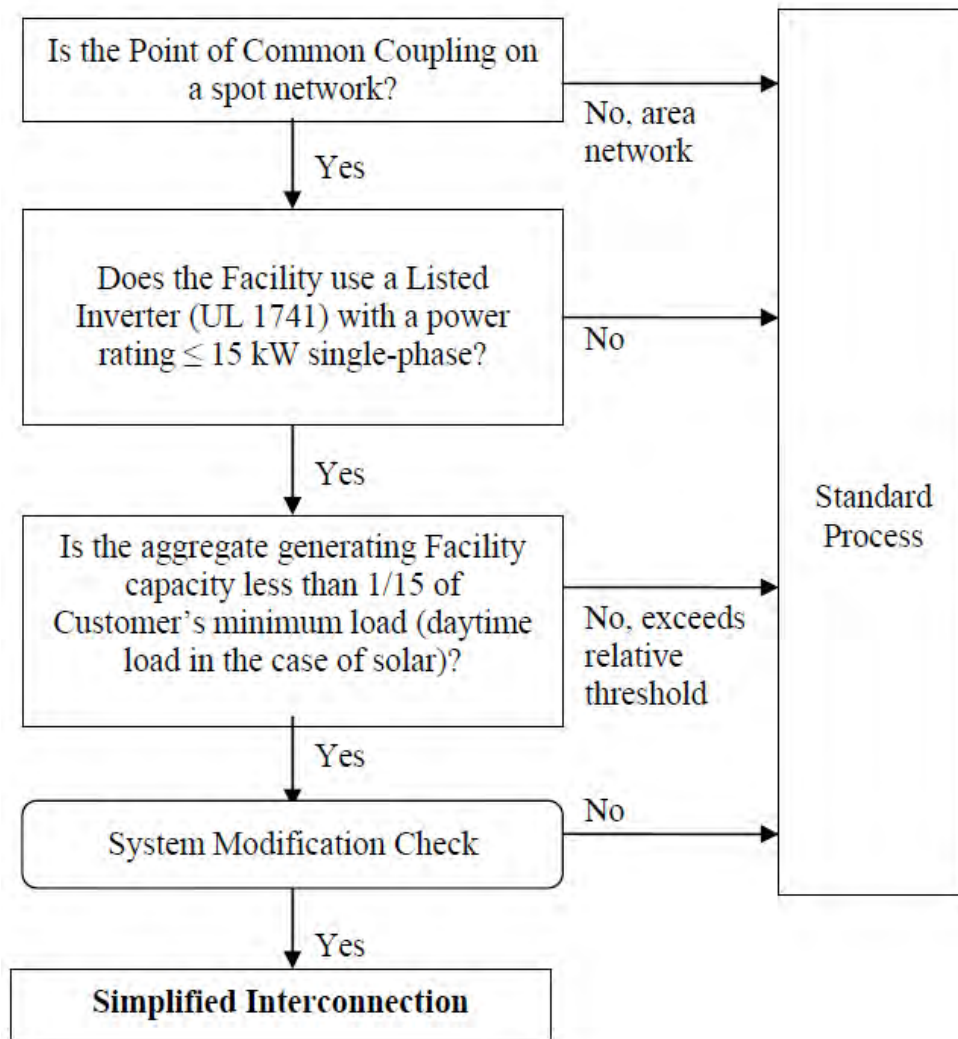

Table 1 – Time Frames (Note 1)

Review Process	Simplified	Expedited	Standard	Simplified Spot Network
Eligible Facilities	Listed Small Inverter	Listed DG	Any DG	Listed Inverter ≤ 15 kW single-phase
Acknowledge receipt of Application	(3 days)	(3 days)	(3 days)	(3 days)
Review Application for completeness	10 days	10 days	10 days	10 days
Complete Review of all screens	10 days	25 days	↓	Site review 30/90 days (Note 2)
Complete Supplemental Review (if needed)	↓	20 days	↓	↓
Complete Standard Process Initial Review	↓	↓	20 days	↓
Send Follow-on Studies Cost/Agreement	↓	↓	5 days	↓
Complete Impact Study (if needed)	↓	↓	55 days	↓
Complete Detailed Study (if needed)	↓	↓	30 days	↓
Send Executable Agreement (Note 3)	Done	10 days	15 days	Done (comparable to Simplified for radial)
Total Maximum Days (Note 4)	15 days	40/ 60 days (Note 5)	125/150 days (Note 6)	40/ 100 days
Notice/ Witness Test	< 1 day with 10 day notice or by mutual agreement	1-2 days with 10 day notice or by mutual agreement	By mutual agreement	1 day with 10- day notice or by mutual agreement

For explanatory notes accompanying Table 1, see [M.D.P.U. 1176](#), sheet 22.

EXHIBIT 2: Company Requirements for Projects Not Eligible for the Simplified Process

These are Company items to be considered in the Customer's DG Project Schedule.

ID	Activity Description	MA SIDG § or ESB ref.
Project Definition & Conceptual Analysis Phase		
1	Customer M.D.P.U. 1176 Exhibit B Expedited/Standard Interconnection Application Form w/technical submittal & prelim. design received	3.2 or 3.3, Figure 1, Table 1
2	Company Preliminary Technical Assessment & cost estimate for Impact or Detailed Study	3.0, Table 2
3	Company M.D.P.U. 1176 Exhibit F or G Retail Connection Agreement executed with Customer	Exhibit F or G
4	Customer commits to Impact or Detailed Study and provides advance payment	5.0
Final Design Review Phase		
5	Company completes Impact or Detailed Study/Service Plan	3.2 or 3.3, Figure 1, Table 1
6	Customer commits to utility system modifications in Impact or Detailed Study/Service Plan and provides advance payment	4.0, 5.0
7	Customer's project schedule and final design & specifications received	4.0 – 8.0, ESB 750 & 752 or 753 or 754 or 758
8	Company reviews Customer's design & returns comments	4.0 – 8.0, ESB 752 or 753 or 754 or 758
Installation Progress Review Phase		
9	Customer's corrected design, test reports & settings received	4.0 – 8.0, ESB 752 or 753 or 754 or 758
10	Company reviews Customer's design & returns comments	4.0 – 8.0, ESB 752 or 753 or 754 or 758
11	Company field audit of Customer's installation progress	4.0 - 6.0
Installation Compliance Verification Phase		
12	Customer's advance notice of functional testing received	4.2.4, ESB 755
13	Electrical inspection certification approval received from municipal codes enforcement	ESB 750 & 752 or 753 or 754 or 758
14	Customer's acknowledgement of satisfactory wiring & relay calibration tests received	4.2.4, ESB 755
15	Company witness of Customer's functional testing	4.2.4, ESB 755
16	Company field audit of Customer's service connection	4.0 – 6.0, ESB 750 & 752 or 753 or 754 or 758
17	Customer resolves open items	ESB 750 & 752 or 753 or 754 or 758
Energization & Synchronization Phase		
18	Verification testing satisfied	4.2.4
19	Company's metering installation complete	8.0, ESB 750 & 752 or 753 or 754 or 758
20	Company's supply system interconnection complete	4.0, 5.0
21	Company review/acceptance of Customer's resolved open items	
22	Customer's Certificate of Completion received (and energization sequence plan for interconnections >600V)	3.2 or 3.3, ESB 755
23	Company proceeds with energization	
24	Customer is permitted to synchronize generation facility in parallel to the Company's supply	
Project Closeout Phase		
25	For interconnections >600V, remainder of Customer's protective system functional testing documented in an acknowledgement letter submitted to the Company within 10 business days after energization	ESB 755
26	Customer's as-built design drawings received within 90 days for interconnections >600V	ESB 750 § 1.7
27	Company reconciliation of project costs with Customer	When requested by Customer.

EXHIBIT 3: Reference Maps of National Grid Massachusetts Secondary Network EPS Areas

Bay State North/West Division

Lynn and Worcester

Bay State South Division

Brockton

[Maps are to be developed.]

National Grid customers in the downtown districts of Brockton, Lynn, and Worcester can contact via E-mail addressed to Distributed.Generation@nationalgrid.com to determine if the proposed location is served in National Grid's Secondary Network area.

EXHIBIT 4: Distribution Secondary Grid Network Description

In Massachusetts, National Grid generally has two types of electrical distribution systems: radial and distribution secondary network systems. While the vast majority of customers are served from radial power systems, some customers in the downtown districts of Brockton, Lynn, and Worcester in Massachusetts are served by distribution secondary network systems; see **Exhibit 3** for area maps. These systems are designed to meet the higher reliability needs, dense load levels, and limited space commonly encountered in urban areas.

A distribution secondary network system delivers electricity through a complex and integrated system of transformers and underground cables that are connected and operate in parallel. Power can flow in either direction on the secondary service delivery lines, commonly called secondary distribution lines. The loss of a single line or transformer in a secondary network system does not cause an interruption of power, unlike radial systems where there is only one line and one path for power to flow from the distribution substation to the customer's point of service. If a radial system experiences an outage, service is interrupted to the customers until repairs are completed; this is less likely to be the case in a distribution secondary network system.

In distribution secondary network systems, devices called "network protectors" are usually arranged to automatically connect its associated transformer to the network system when conditions are such that the transformer when connected will supply power to the network and to automatically disconnect the transformer from the network when power flows from the network to the transformer. The integration of DG into a distribution secondary network system may result in network protectors exceeding their original design criteria or nameplate ratings.

Example Distribution Secondary Grid Network Diagram

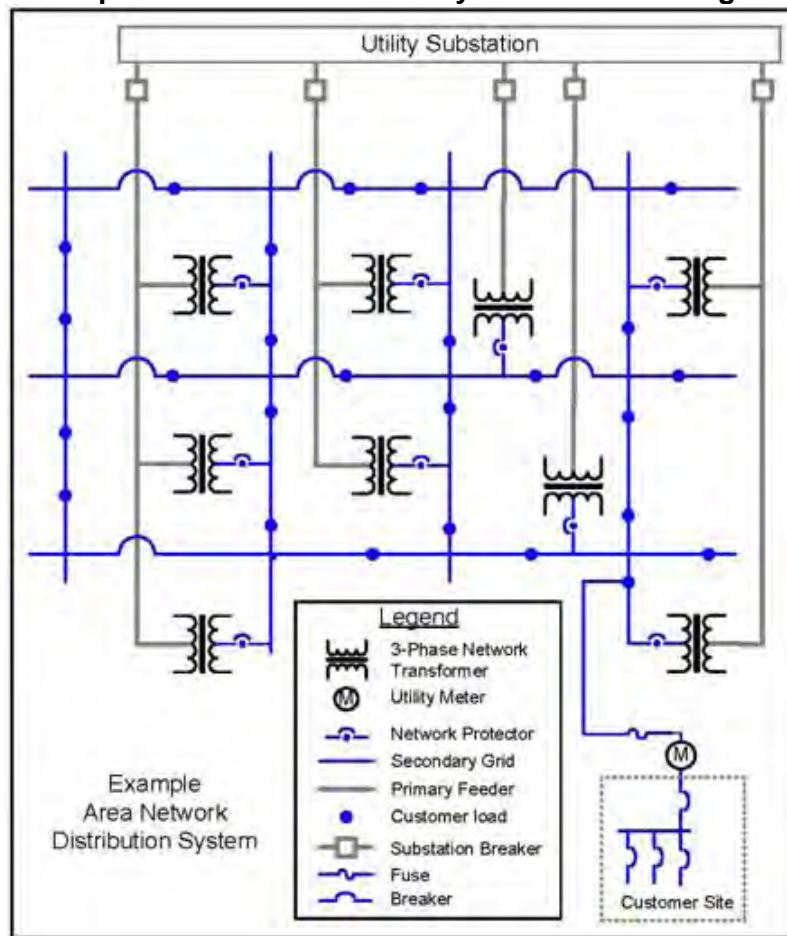

EXHIBIT 5: Recommended Guidelines for Residential and Commercial Single-line Diagram Submittals

Refer to **Figures 1** and **2** for typical illustrations.

1. Identify the project, Company's electric service order (ESO) number, location and submitter's name and address.
2. Indicate standard and any non-standard system voltages, number of phases, and frequency of the incoming circuit. Indicate wye and delta systems; show whether grounded or ungrounded.
3. Identify cable, conductors and conduit, the type and number. The Company is interested in how the power is getting from the service point to the protective equipment.
4. Identify wiring troughs and/or junction boxes where used.
5. Use standard symbols. See **NFPA 70B** or **IEEE Standard 141** for symbols in typical electrical single-line diagram development.
6. Identify the service equipment's switch and fuse or circuit breaker as to manufacturer, type, rating, catalog number, etc. Catalog cuts are not required for most major manufacturers. Service equipment must be able to safely interrupt the maximum available fault current from the supply; refer to **NEC** Articles 110 and 230.
7. Show billing meter trough or instrument transformers' cabinet (C.T. cabinet) in circuitry. Indicate source and load for the circuit. Refer to Section 7 in the Company's **ESB 750** for acceptable metering configurations.
8. Identify other protective devices and ratings. Include ratings in volts and amps, the interruption rating, and type and number of trip coils on circuit breakers. Also, note any special features of fuses (current limiting, dual element, etc.).
9. Identify ratios of current and potential transformers, taps to be used on multi-ratio transformers, and connection of dual ratio current transformers if used.
10. Identify any relays, if used, and their functions.
11. Show connections and ratings of power transformer windings for any to be used.
12. Identify Generator Disconnect and its ratings.

FIGURE 1: Sample Residential Photovoltaic Distributed Generator Installation – Single Phase, Net Metering

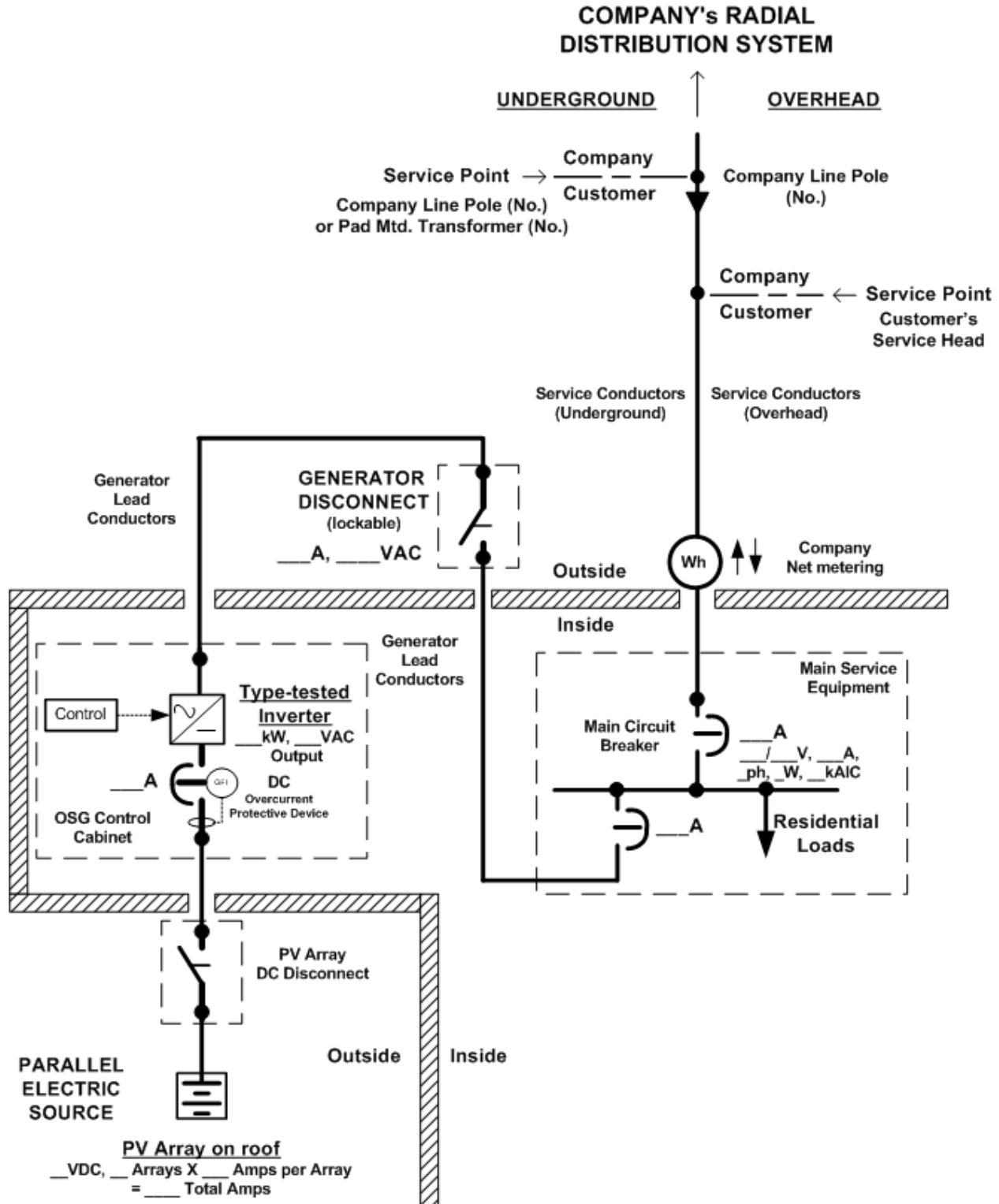

FIGURE 2: Sample Commercial Distributed Generator Installation

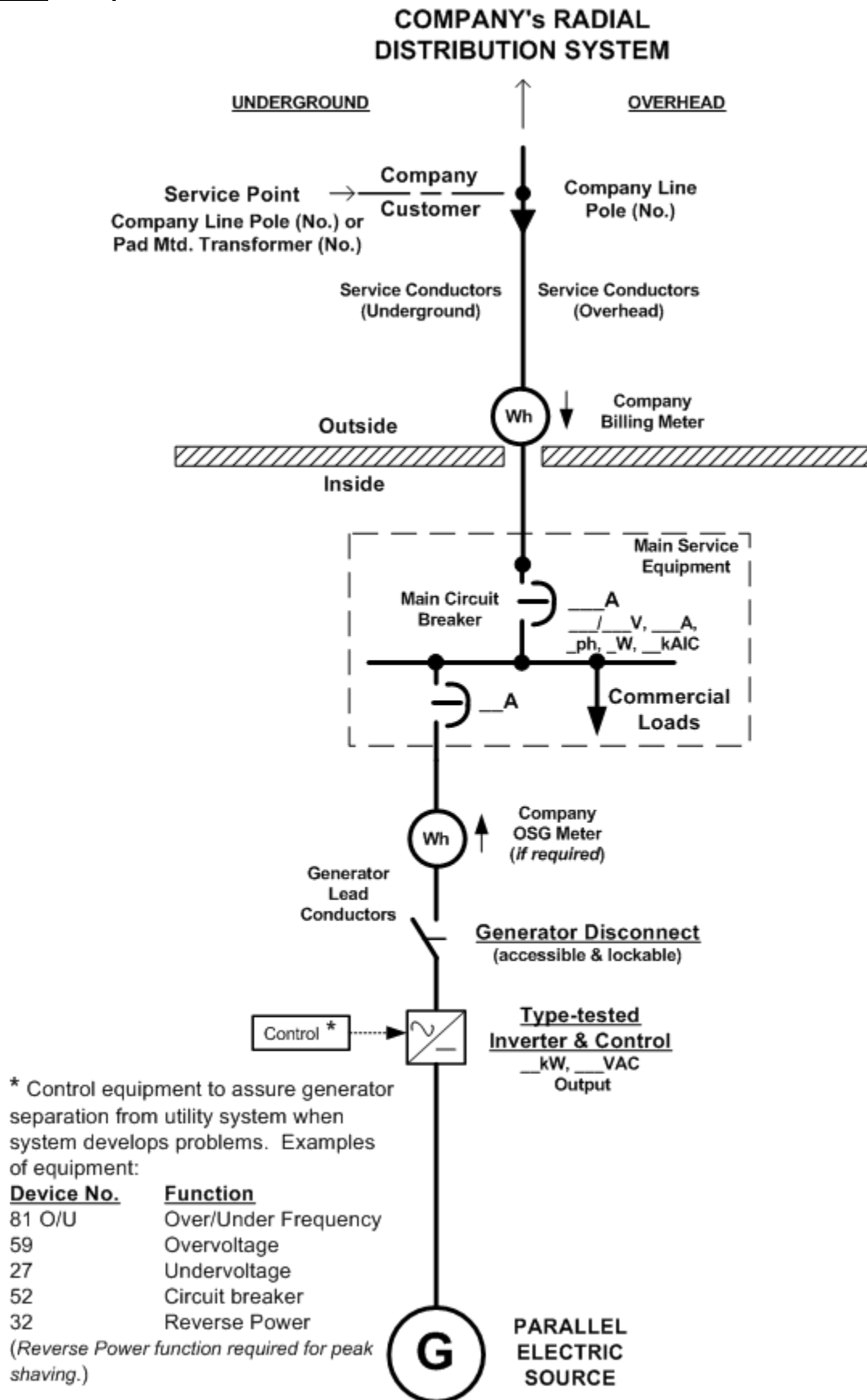

EXHIBIT 6: Recommended Guidelines for Functional Single-line Diagram Submittals

Refer to **Figures 3** and **4** for typical illustrations.

In addition to **Exhibit 5**:

13. On functional single-line diagram submittals, industry standard device numbers are necessary. Refer to the following List of Standard Device Numbers (See latest edition of **ANSI C 37.2**):

<u>Device Number</u>	<u>Function</u>
25	Synchronizing Device
27	Undervoltage Relay
32	Directional Power Relay
46	Negative Sequence Voltage
50	Instantaneous Overcurrent Relay
51	Phase Overcurrent Relay
51N	Neutral Overcurrent Relay
51V	Overcurrent Relay, voltage restraint
51C	Voltage controlled overcurrent
52	Breaker
52R	Recloser
59	Overvoltage Relay
59G	Neutral Voltage Relay
59N	Zero Sequence Voltage Relay
62	Time-delay Stopping or Opening Relay
64	Ground Protective Relay
81	Over and Under Frequency Relay
86	Locking - Out Relay
87	Differential Relay

FIGURE 4: Typical $3V_0$ Requirements for Local EPS Ground Fault Detection

The Company requires ground protection on any system that can be a generation source and to protect transformers that can be paralleled and supplied from two sources. In these cases, a “zero-sequence” voltage or “ $3V_0$ ” scheme will be required on the primary side of a delta primary wound transformer supplying the facility. Typically, the added relaying on the primary side of the transformer is a ground overvoltage device function 59N or 59G relay that can detect the presence of the single line-to-ground fault on the Local EPS. This is implemented by installing potential transformers (PTs) on the delta primary system as a source to a voltage sensing relay that would trip the primary side protective device. For a delta secondary wound transformer supplying the facility, the same “zero-sequence” voltage or “ $3V_0$ ” scheme is required on the secondary side but will open the transformer primary side protection.

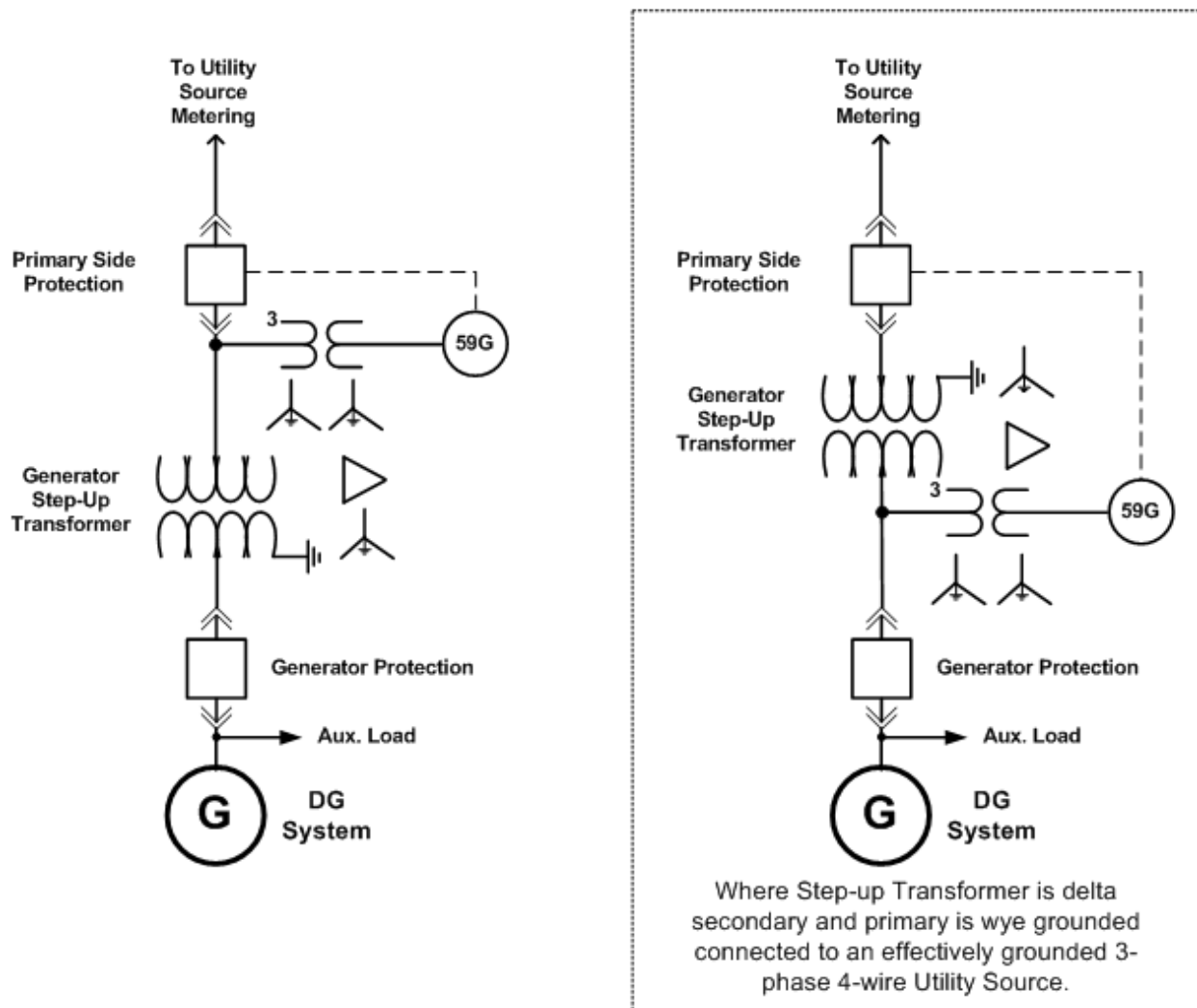

-- INFORMATION ONLY --
 -- SIMPLIFIED DIAGRAMS NOT
 ALL DETAILS SHOWN --

EXHIBIT 7: Typical Overhead Primary Service Configuration for Large DG Installations >500kW

The DG Customer will be required to install a pole to the Company's specifications on which the Company will install cross arms and dead end the Company's primary service conductors. This point will be the physical Point of Common Coupling (PCC). At this pole the Customer-owned, 3-phase gang operated, Generator Disconnect switch can be installed and connected to the Company's primary service conductors by the DG Customer.

All Company-owned service lateral facilities and equipment on private property will require easements. These easements will be the responsibility of the DG Customer to obtain in accordance with the Company's specific electric service requirements; see ESB 750.

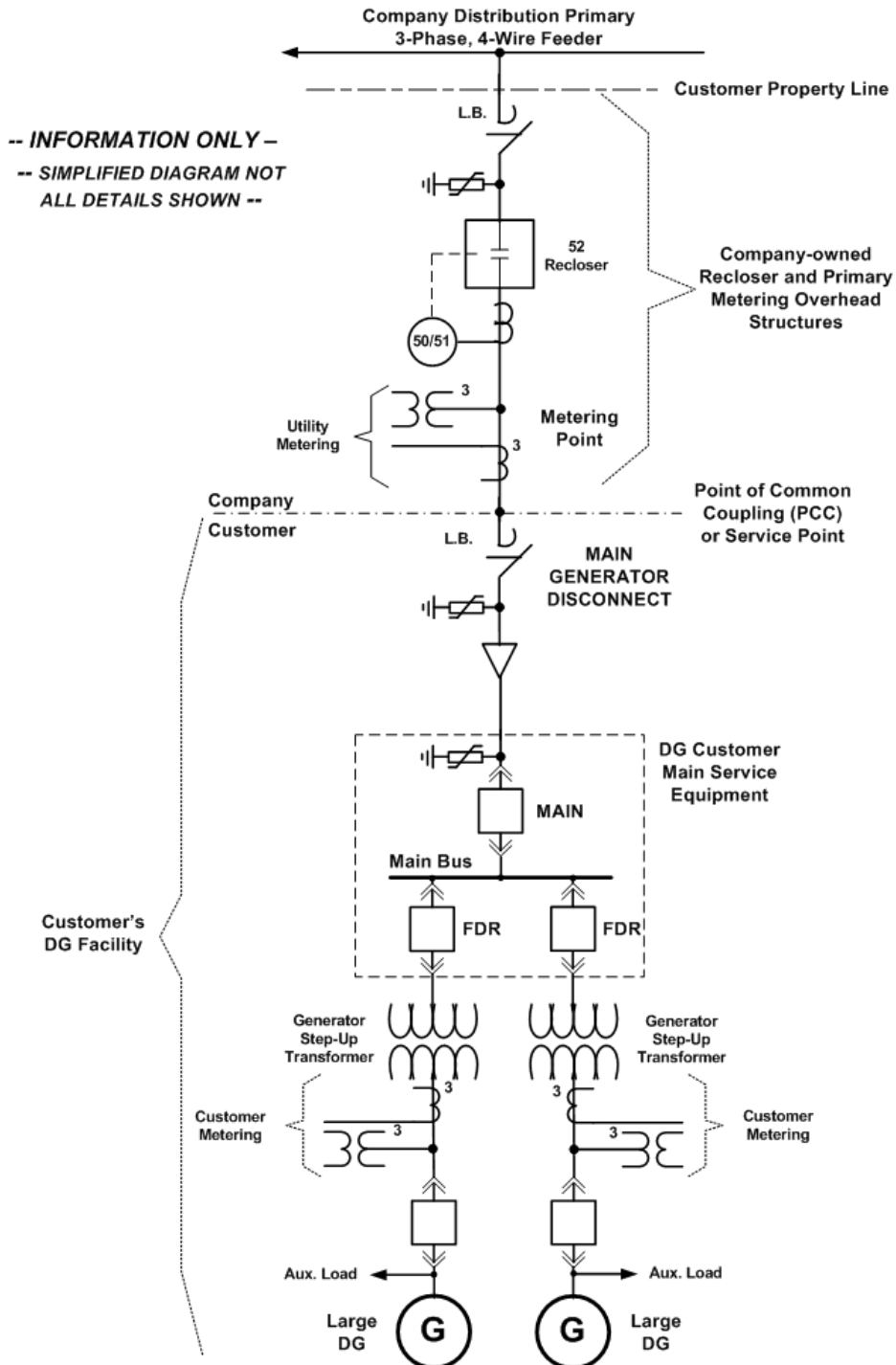

EXHIBIT 8: Net Metering Compliance Verification Checklist (Simplified Process)

Account Number: _____

Customer Name: _____ Phone # _____
Last First Work Phone # _____

Service Address: _____
Number Street Town/City Zip

Billing Address: _____
Number Street Town/City Zip

Qualified Installer: _____ License # _____ Phone # _____
Last First (if available) Cellular # _____

Address: _____ FAX # _____
Number Street Town/City Zip Pager # _____

✓ **Verify One-Line Diagram (installed equipment)**

_____ Inverter Model _____ or Intertie Multifunction Relay Model _____

_____ Software version _____

_____ Company billing meter s/n _____ Net-meter One Meter Option: YES ___ NO ___

_____ Inspection received? YES ___ Number _____ (attach copy of approval certificate)
 NO ___, then stop and await inspection approval.

✓ **Verify Plot Plan (equipment's location)**

_____ "Generator Disconnect Switch" is at agreed location: YES ___ NO ___.

_____ "Generator Disconnect Switch" is labeled as such: YES ___ NO ___.

_____ Label is at meter location to identify location of Generator Disconnect: YES ___ NO ___.

✓ **Verify DG System Is Operating (producing power)**

_____ Verify "Generator Disconnect Switch" is Open.

_____ Verify voltage is **zero volts** on DG side of open "Generator Disconnect Switch": YES ___ NO ___.

_____ Close "Generator Disconnect Switch".

_____ Verify DG Inverter or Intertie Multifunction Relay alarms and **voltage present** on utility side of "Generator Disconnect Switch": YES ___ NO ___.

✓ **Restoration of Utility Power Test**

_____ Open "Generator Disconnect Switch", **pause at least 1 to 2 minutes**, then Close "Generator Disconnect Switch". Record time when "Generator Disconnect Switch" is closed: _____

_____ Record time when **DG starts** producing power: _____. Is the time between the "Generator Disconnect Switch" closure and when DG Inverter or Intertie Multifunction Relay permits synchronization to utility source **greater than 5 minutes**? YES ___ NO ___

✓ **24 Hour Telephone Number Contact**

Name: _____ Number (_____) - _____

Performed by: _____ *signature*: _____ Date: _____
Name (Customer's qualified installer.)

Witnessed by: _____ *signature*: _____ Date: _____
Name (Company witness.)

Electric System Bulletin No. 756 Appendix D:

Distributed Generation Connected To National Grid Distribution Facilities Per The Rhode Island Standards for Connecting Distributed Generation

August 2012 version 2.0

ESB 756 Appendix D is part of the ESB 750 series



PREFACE

Electric System Bulletin 756 Appendix D is a technical bulletin covering The Narragansett Electric Company Standards for Connecting Distributed Generation R.I.P.U.C. No 2078 (Canceling R.I.P.U.C. No. 2007) Effective: November 30, 2011.

* https://www.nationalgridus.com/non_html/StdCnctDG2078_11-30-11.pdf

This is an appendix to ESB 756 and is available from the Company's web site and may be obtained:

- From the Internet at <http://www.nationalgridus.com/electricalspecifications>,
- Or in printed form by contacting either of the Call Centers in Massachusetts or New York (see inside cover of ESB 750). However, printed copies are not document controlled, so for the latest authorized version please refer to the Company's website.

TABLE of CONTENTS

SECTION	PAGE
TABLE of CONTENTS	3
1.0 Purpose	4
2.0 Scope	5
3.0 Customer Interface Procedures.....	5
3.1 APPLICATION PROCESS OVERVIEW	5
3.2 OBJECTIVES IN THE APPLICATION PROCESS.....	5
3.3 CONSIDERATIONS DURING THE APPLICATION PROCESS.....	7
3.4 INTERCONNECTION CHARGES.....	8
Table 3.4-1: DG Projects where no EPS upgrades are expected	8
Table 3.4-2: Complex DG Projects	9
4.0 Overview of Potential Issues Related to Interconnection.....	9
ILLUSTRATION 4.6-1: TYPICAL DG INSTALLATION AREAS ON RADIAL DISTRIBUTION FEEDERS....	10
TABLE 4.6-1: TYPICAL PLANNING LIMITS FOR DG CONNECTION TO RADIAL DISTRIBUTION FEEDER	10
5.0 General Design and Operating Requirements.....	12
5.1 APPLICABLE CODES, STANDARDS, AND GUIDELINES	12
5.2 DEFINITIONS	13
5.3 GENERAL CRITERIA	13
5.3.1 Single Phase	13
5.3.2 Three Phase.....	13
5.3.3 Phase Balance	13
5.3.4 Neutral Stabilization and Grounding.....	13
5.4 SERVICE EQUIPMENT AND REVENUE METERING.....	14
5.4.1 Service Equipment Requirements.....	14
5.4.2 Company Revenue Metering Requirements	14
5.5 TRANSFORMER	14
5.5.1 Purpose for DG Facility Interconnecting Transformer	14
5.5.2 Secondary Served DG Customers	14
5.5.3 Primary and Higher Voltage Served DG Customers	15
5.5.3.1 Effectively Grounded, Four-wire Multi-grounded 3-phase Wye EPS:.....	15
5.5.3.2 Not Effectively Grounded, Three-wire 3-phase EPS:	15
5.6 MANUAL GENERATOR DISCONNECT SWITCH	15
5.7 PROTECTIVE DEVICE EQUIPMENT	16
5.7.1 Protection Requirements.....	16
5.7.2 Interconnection Interrupting Device.....	16
5.7.3 Interconnection Transformer Configuration.....	16
5.7.4 Instrument Transformers for Protective Device Relays	16
5.7.4.1 Current Transformers (“CT”).....	16
5.7.4.2 Voltage Transformers (“VT”) and Connections.....	16
5.7.5 Synchronizing Devices	17
5.7.6 Voltage Relays	17
5.7.7 Frequency Relays	17
5.7.8 Overcurrent Relays	17
5.7.9 Type Tested Equipment	17
5.7.10 Non-Type Tested Equipment	17
5.7.10.1 Photovoltaic (PV) Generation	17
5.7.10.2 All Other Parallel Generation Equal or Above 500kW	18
5.7.10.3 Protective Relay Hard-Wire Requirement	18
5.7.10.4 Interconnection Interrupter Tripping and Protective Relay Supply	18
5.7.10.5 Use of Microprocessor Based Relays	19
5.7.11 Utility Grade Protective Device Settings and Verification	19
5.7.11.1 Company-designated Relays and Customer Settings.....	19

TABLE of CONTENTS

<u>SECTION</u>	<u>PAGE</u>
5.7.11.2 Company Verification of Relay Testing	19
5.7.12 Anti-islanding.....	19
5.7.12.1 Inverter-based Photovoltaic (PV) Generation	20
5.7.12.2 All Other Parallel Generation Except PV Generators	20
5.7.12.3 High-Speed Protection	20
5.7.12.4 DTT Installation Requirements	20
5.7.13 Power Quality Compliance Verification	20
6.0 OPERATING	21
6.1 POWER FACTOR	21
6.2 POWER QUALITY MONITORING	21
6.3 ISOLATION	21
6.4 ENERGY MANAGEMENT SYSTEM-REMOTE TERMINAL UNIT (EMS-RTU).....	21
6.5 BALANCE OF CUSTOMER EQUIPMENT.....	22
7.0 REVISION HISTORY	22
EXHIBITS ATTACHED.....	22
EXHIBIT 1: R.I.P.U.C. 2078 TARIFF FIGURES 1 AND 2 AND TABLE 1	23
EXHIBIT 2: COMPANY REQUIREMENTS FOR PROJECTS NOT ELIGIBLE FOR THE SIMPLIFIED PROCESS	26
EXHIBIT 3: REFERENCE MAPS OF NATIONAL GRID RHODE ISLAND SECONDARY NETWORK EPS AREAS	27
EXHIBIT 4: DISTRIBUTION SECONDARY GRID NETWORK DESCRIPTION.....	28
EXHIBIT 5: RECOMMENDED GUIDELINES FOR RESIDENTIAL AND COMMERCIAL SINGLE-LINE DIAGRAM SUBMITTALS	29
FIGURE 1: Sample Residential Photovoltaic Distributed Generator Installation – Single Phase, Net Metering.....	30
FIGURE 2: Sample Commercial Distributed Generator Installation	31
EXHIBIT 6: RECOMMENDED GUIDELINES FOR FUNCTIONAL SINGLE-LINE DIAGRAM SUBMITTALS	32
FIGURE 3: Sample Functional Single-Line Diagram.....	33
FIGURE 4: Typical 3V ₀ Requirements for Local EPS Ground Fault Detection.....	34
EXHIBIT 7: TYPICAL OVERHEAD PRIMARY SERVICE CONFIGURATION FOR LARGE DG INSTALLATIONS 500KW AND ABOVE.....	35
EXHIBIT 8: NET METERING COMPLIANCE VERIFICATION CHECKLIST (SIMPLIFIED PROCESS)	36

1.0 Purpose

1. National Grid strongly believes that promoting the installation of Distributed Generation (DG) facilities, in accordance with the Rhode Island Standards for Connecting Distributed Generation (RI SCDG or SCDG), is sound public policy. This belief includes DG facilities on network systems to the extent technically feasible.
2. The purpose of this Electric System Bulletin (ESB) is to assist customers desiring to interconnect DG projects to National Grid's Rhode Island distribution system for State jurisdictional projects. If a project will be selling energy to a third party, not National Grid as a Qualifying Facility (QF) or under the net-metering tariff, then the project is FERC jurisdictional. As such, the Customer will need to apply and work with the ISO-NE (http://www.iso-ne.com/genrion_resrcs/nwgen_inter/index.html) for interconnection to the distribution system, following the application requirements of the FERC Small Generator Interconnection Procedure (SGIP) and ISO-NE Schedule 23.
3. This ESB supplements **ESB 750** and the **RI SCDG** and provides general technical requirements, recommendations, and assistance to customers regarding the DG facilities connected in parallel to the Company's distribution electric power system (Company

Distribution EPS). These projects are typically 5 MWs or smaller in size. Note that the SCDG does not apply to DG units larger than 10 MW.

2.0 Scope

1. All generating interfacing equipment must be designed, installed, interconnected, tested, and operated in accordance with applicable government, industry, and Company standards. The provisions of this bulletin only pertain to those types of parallel generation covered by the RI SCDG connected to the Company Distribution EPS that are net metered generation sources (Net Metered Classes) or non-net metered generation sources. For FERC jurisdictional projects connected to the Company Distribution EPS, the technical provisions of this document also apply.
2. These requirements are limited to only those points in which the Customer and the Company have a mutual interest to ensure safety to Company employees and the public and satisfactory operation and compatibility with the electrical supply to others served by the Company distribution EPS.
3. Technical requirements for parallel operated on-site generators (OSG) not covered by this document may be found in [ESB 756 Appendix A](#).

3.0 Customer Interface Procedures

3.1 Application Process Overview

This section outlines the process for a Customer to receive Company approval to interconnect DG facilities to the Company Distribution EPS. This process is intended for the following:

1. New DG facilities that are eligible under the [RI SCDG](#) process;
2. Review of any modifications affecting the Company Distribution EPS and service connection interface at the point of common coupling (PCC) of existing Customer DG facilities that: (i) are eligible under the SCDG process; and (ii) have been interconnected to the Company Distribution EPS where an existing retail interconnection agreement between the Customer and the Company is in place; and
3. In all other cases, the Company will, where possible, use a similar application and approval process as outlined in the SCDG for DG types of facilities.

This application process and its requirements do not apply to generation equipment that will never be allowed to operate in parallel with the Company Distribution EPS. For example, this process does not apply to emergency standby generators with break-before-make transfer switches and any other generation sources that operate independently of any connection to the Company Distribution EPS and have no provision for such connection (even for a short period of time).

As stated above, this application process is mandated by the Rhode Island Department of Public Utilities (DPU) for customer generation equipment that will be connected to the Company Distribution EPS on a full or part time basis; see RI SCDG contained in National Grid's Rhode Island and Nantucket electricity tariff, R.I.P.U.C. 2078 (https://www.nationalgridus.com/non_html/StdsCnnctDG2078_11-30-11.pdf).

3.2 Objectives in the Application Process

1. Parallel operation of a generator becomes a part of the Company Distribution EPS and where the Customer and the Company have a mutual interest the interconnection is required to preserve the safety, reliability, security, power quality, and operational efficiency needs of the Company Distribution EPS. This is necessary to ensure safety to the public and to Company employees and satisfactory operation and compatibility with the electrical supply to others. The steps and timing requirements of the application process are identified within the [RI SCDG](#). Although timing is driven by the SCDG, the time required to complete necessary engineering studies may depend on the characteristics of the generator, the size class (as specified above), its intended operating modes, customer

submittal of technical data and design, and the characteristics of the Company Distribution EPS at the point of interconnection (POI).

2. Additional site-specific requirements may be indicated once the supply voltage, service arrangement, location, and generation purpose is determined, where such purpose can be either:
 - peak shaving*,
 - net energy metering for solar, wind, or agricultural projects as under the Company's net-metering tariff, R.I.P.U.C. 2099, or
 - export energy for a QF with an agreement for sales** according to the Company's tariff provisions.

** Peak shaving generation is Customer-owned generation operated in parallel with the Company to reduce a Customer's electrical demand. Unlike net metering, peak shaving generation is not permitted to flow into the utility supply system upstream of the billing meter and will require the installation of protection devices. The Company's revenue metering is detented in this case to prevent reverse billing meter registration.*

*** An Agreement for Sales of Export Energy for a QF under a RI SCDG application may be made per the Company's R.I.P.U.C. 2074 electricity tariff and is a Power Purchase Agreement.*

3. For new electric service or modifications to electric service to accommodate the Customer's parallel generator, refer to the Company's latest revision of ESB No. 750, Specifications for Electrical Installations. The Customer will be responsible for any permitting and conformance to the latest revision of all local, state and federal codes and national standards that apply. For example, under RI and municipal building code requirements the Customer will need to provide evidence of electrical inspection approval from their local municipal code enforcement agency.
4. When considering a DG interconnection arrangement, an R.I.P.U.C. 2078 Exhibit A or B application is submitted to the Company's Distributed Generation Services department.
5. Any subsequent sale of an On-Site Generator (OSG) facility covered by the requirements of the RI SCDG of the original retail Customer's facility will require the new owner to establish a separate interconnection agreement (R.I.P.U.C. 2078 Exhibit G and/or H) for the generation.
6. Refer to:
 - The steps to install distributed generation in Rhode Island as specified in the RI SCDG; see Section 3.0 of R.I.P.U.C. 2078 (https://www.nationalgridus.com/non_html/StdscnctDG2078_11-30-11.pdf),
 - Attached **Exhibit 1** from the Company's electricity tariff, R.I.P.U.C. 2078, Figures 1 and 2 and Table 1 application process,
 - Attached **Exhibit 2** for Company requirements for projects not eligible for the Simplified Process,
 - The Company's Technical Sales & Engineering Support (TSES) department's **electronic mail address** as follows for inquiries: Distributed.Generation@nationalgrid.com, and
 - The Company's (www.nationalgridus.com) "Distributed Generation" web site at http://www.nationalgridus.com/narragansett/home/energyeff/4_interconnect.asp for information and forms listed below (from R.I.P.U.C. 2078 https://www.nationalgridus.com/non_html/StdscnctDG2078_11-30-11.pdf) when making an application with the Company:
 - Simplified Process application form and service agreement ([Exhibit A](#))
 - Expedited and Standard Process application form ([Exhibit B](#))

- Supplemental Review Agreement (for those projects which have failed one or more screens in the Expedited Process) (Exhibit C)
 - Feasibility Study Agreement (Exhibit D)
 - Impact Study Agreement or Impact Study for Renewable DG (ISR DG) Agreement under the Standard Process (Exhibit E)
 - Detailed Study Agreement (for the more detailed study under the Standard Process which requires substantial System Modifications) (Exhibit F)
 - [Schedule B](#) Additional Information Required for Net Metering service
 - Interconnection Service Agreement (Exhibit G)
 - Agreement between the Company and the Company's Retail Customer (Exhibit H)
- The following Independent System Operator-New England (ISO-NE) requirements apply under this bulletin:
- DG projects 60kW or larger that will export power require asset registration by the Company's TSES department to ISO-NE.
 - DG projects greater than 1 MW but less than 5 MW will require a notification by the Company's TSES department to ISO-NE via Attachment 4 under ISO-NE Planning Procedure (PP) 5-1.
 - DG projects 5 MW and greater will require a review of transmission system impacts and a Proposed Plan Application filed with ISO-NE. Refer to ISO-NE PP 5-1.
7. The application process and attendant services are offered by the Company on a non-discriminatory basis to any customer. As part of the process, the Company may identify the need for detailed engineering studies, distribution system upgrades and additional protection requirements. As allowed by the Rhode Island PUC, the costs of the detailed study and upgrades are the responsibility of the Customer. If the Customer makes significant changes in the design or scheduling of their DG project, then any previous information furnished by the Company to the Customer is subject to review and possible change, which may cause a delay in service.
8. The application process is structured to allow the Customer to review each cost in advance so that the Customer may choose whether or not to continue moving forward with the process prior to committing to these costs. This avoids unnecessary expenditure of resources by either party and is for the benefit of both the Customer and the Company. Where a service upgrade is necessary and is above the base interconnection cost limits in the SCDG, refer to the Narragansett Electric Company Terms and Conditions for Electricity Service and Policies, R.I.P.U.C. 2040 (http://www.nationalgridus.com/narragansett/non_html/rates_tariff.pdf) and ESB 750 (https://www.nationalgridus.com/non_html/shared_constr_esb750.pdf).
9. The following website contains the Company's application of the RI SCDG net metering rules: http://www.nationalgridus.com/narragansett/home/energyeff/4_net-mtr.asp.

3.3 Considerations During the Application Process

1. When applying for a DG interconnection within the Company's secondary area network and secondary spot network EPS located in the downtown districts of Pawtucket and Providence in Rhode Island, DG installations on distribution secondary network systems may require a study to be undertaken to ensure the DG facility does not degrade the reliability, power quality, safety, or operation of the Company's network system. Therefore, customers in the downtown districts of Pawtucket and Providence **should contact the Company's TSES department** (Distributed.Generation@nationalgrid.com) to determine if the proposed location is served by a distribution secondary network system. This should be done while the project is still in the planning stage, and certainly before purchasing equipment or beginning installation. The Company's TSES department will review the Customer's plans

and discuss options with the Customer. Refer to attached **Exhibit 3** for area maps locating the Company's secondary network service areas [*to be developed*].

Unlike radial distribution systems that deliver power to each customer in a single path from source to load, underground secondary area network systems deliver power to each customer through a complex and integrated system of multiple transformers and underground cables that are connected and operate in parallel; refer to attached **Exhibit 4** for more information. The connection of customer DG facilities on networks is an emerging topic, which **(i)** poses some issues for the Company to maintain adequate voltage and worker safety and **(ii)** has the potential to cause the power flow on network feeders to shift (i.e., reverse) causing network protectors within the network grid to trip open. Therefore, to ensure network safety and reliability additional information will be required for the Company's engineering analysis such as:

- Customer's existing* or proposed electric demand profile showing minimum load during peak generation time,
- Customer's expected generation profile shown for a 24-hour period and typical 7-day duration, and
- Customer's complete electric service single-line diagram showing the configuration of the proposed generation and other metered tenants, if any, up to the service point supplied by the Company's secondary network EPS.

** In addition, the Company may need to install recording equipment at all metered electricity users to determine the total demand of the building's network service when obtaining the service connection's electric demand profile. The cost to the Customer will be according to the Company's electric customer load survey flat rate and charged in accordance with the terms of the Company's electricity tariff and RI SCDG.*

2. For more technical information on parallel generator installations, please refer to this bulletin's remaining sections.

3.4 Interconnection Charges

Customers shall be subject to charges for interconnection costs. To permit interconnected operations with a customer, the Company may incur costs. These costs, called interconnection costs, are directly related to the installation of those facilities the Company deems necessary for interconnection. They include initial engineering evaluations, purchase and installation of additional switching, transmission, distribution, and communication equipment at Company's facilities, safety provisions, engineering and administration. These costs shall be paid in full by the Customer prior to commencement of service in accordance with the Company's electricity tariffs, R.I.P.U.C. 2078 and 2040 and the **RI SCDG**. For typical Company interconnection cost items expected in DG projects that will be defined in either an Impact or a Detailed Study, see the following two tables. Costs will be determined according to the Company's electricity tariff and the RI SCDG.

Table 3.4-1: DG Projects where no EPS upgrades are expected

Item No.	Typical Company Support Activities Attributed to DG Customer's Project
1	Engineering acceptance review of DG Customer's construction design submittals where the Company has mutual interest such as service connection facilities, meter mounting provisions, Company-designated protective devices and control schemes according to the Company's ESB 750 series.
2	Revenue metering equipment changes/additions.
3	Field audit of DG Customer installation to accepted design.
4	Field compliance verification - witness tests of DG Customer protective devices coordinating with the Company Distribution EPS.
5	TSES Project Management

Table 3.4-2: Complex DG Projects

Item No.	Typical Company Support Activities Attributed to DG Customer's Project
1	Company Distribution EPS upgrades (e.g., Current Limiting Fuses, Primary Conductors, Line Reclosers, Switches, Voltage Regulators, Capacitors, etc.) as a result of DG impact.
2	Where Local EPS anti-islanding protection is required, DTT transmit addition to Distribution EPS substation feeder breaker (and/or Line Recloser) for DG impact on distribution feeder.
3	Where Company-provided Radio Communications can be applied, additions to support DTT equipment at Distribution EPS substation feeder breaker (and/or Line Recloser) for DG impact on distribution feeder.
4	Where Local EPS feeder selectivity may require prompt control measures for DG impact on distribution feeder operations, EMS-RTU (status & control) addition at the DG facility.
5	Service Connection modifications and additions for DG impact on the Company Distribution EPS.
6	Revenue metering equipment changes/additions.
7	Engineering acceptance review of DG Customer's construction design submittals where the Company has mutual interest such as service connection facilities, meter mounting provisions, Company-designated protective devices and control schemes (e.g., DTT receive package installation at DG) according to the Company's ESB 750 series.
8	Field audit of DG Customer installation to accepted design.
9	Field compliance verification - witness tests of DG Customer protective devices coordinating with the Company Distribution EPS.
10	Project Management (TSES, Distr. Line, Distr. Station, etc.)

4.0 Overview of Potential Issues Related to Interconnection

1. Customer generation connected to the distribution system can cause a variety of system impacts including steady state and transient voltage changes, harmonic distortion, and increased fault current levels. Parallel generation systems, which located individually on higher capacity feeders may not cause very serious impacts, can, on weaker circuits, in aggregation or in special cases (such as lightly loaded networks), significantly impact the Company's Distribution EPS.
2. An Impact Study and a Detailed Study in some cases is needed to identify the severity of system impacts and the upgrades needed to avoid problems on the Company Distribution EPS. Typically, an Impact or Detailed Study will be performed by the utility to determine if the proposed generation on the circuit results in any relay coordination, fault current, and/or voltage regulation problems.
3. There is a wide range of potential issues associated with the interconnection of DG facilities to the Company Distribution EPS including, but not limited to:
 - Impact on step voltage regulation equipment
 - Increased fault duty on Company circuit breakers
 - Interference with the operation of protection systems
 - Harmonic distortion contributions
 - Voltage flicker
 - Ground fault overvoltages
 - Islanding
 - System restoration
 - Power system stability
 - System reinforcement
 - Metering
4. It is important to scrutinize the interconnection of Customer DG facilities to the Company Distribution EPS so that any negative impacts can be avoided and assure that the customer generation will have only a positive or, at least, neutral impact on the EPS performance. It is the intent of any Company study in accordance with SCDG requirements when applicable to avoid negative power system impacts by identifying the particular type of impact that will occur and determining the required equipment upgrades that can be installed to mitigate the issue(s).

5. Anywhere within the Company's service territory that a customer plans to interconnect generation, they will be interfacing to one of two main types of distribution systems. These will be either radial systems or network systems. The interface voltage levels will be either low voltage (less than 600 volts) or medium voltage (greater than 600 volts and less than 15,000 volts) depending on the location on the Company's system and size of the generator.
6. In general, DG facilities connected to various locations on the **radial distribution EPS** are limited as listed in the below Table 4.6-1. This table provides an upper limit that represents the maximum possible DG capacity under ideal situations and assumes that on the Company Distribution EPS there are no additional limitations as indicated by site specific system studies (e.g., available short circuit current contributions, minimum network loading in light loading seasons, voltage regulator interactions, etc.). When a DG facility (or aggregate DG facilities) on a feeder or local EPS of a feeder is above the limits in Table 4.6-1, these warrant further study by the Company to determine feasibility and remedial action.

Illustration 4.6-1: Typical DG Installation Areas on Radial Distribution Feeders

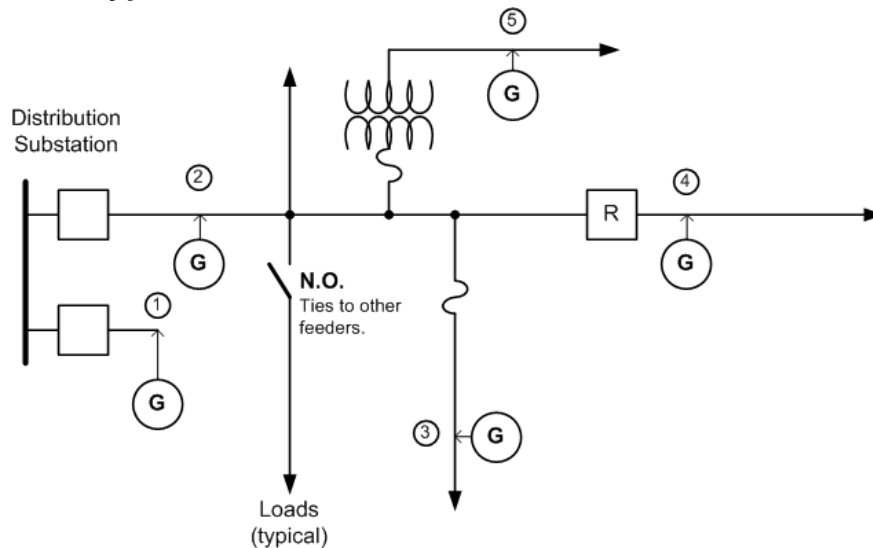

“O” - DG Interconnection Location Point on Feeder

1. Express (dedicated) radial feeder
2. Feeder Main
3. Feeder Branch protected by fuse
4. Sectionalized Feeder Main
5. Feeder Branch protected by fuse with ratio transformer

Table 4.6-1: Typical Planning Limits for DG Connection to Radial Distribution Feeder

Typical Gross Generation Capacity Limit (see notes below)		
DG Location on Feeder	3-phase Radial Distribution Voltage Class System	
	4 or 5kV	15kV
1. Express (dedicated) Radial Feeder	2.8MVA	9.0MVA
2. Feeder Main	0.75MVA	2.5MVA
3. Feeder Branch protected by Fuse	75kVA	250kVA
4. Sectionalized Feeder Main	100kVA	300kVA
5. Feeder Branch protected by Fuse with Ratio Transformer	50kVA	150kVA

Notes to Table 4.6-1:

- a. These generation capacities are on a per-generator basis on full nameplate ratings and at unity power factor. It should be noted, however, that the aggregate generation (sum of the total gross generation of all DG systems connected to a particular segment of the Company's system) is considered for all points along the distribution feeder. The

Company will evaluate each application before deciding on the maximum MVA allowed onto the Company's system at a given point.

- b. *Limits apply to synchronous and induction rotating generator machines. The DG facility shall maintain power factor at the PCC in accordance with the RI SCDG; at 0.90 Power Factor leading or lagging (for Var or voltage support can also be considered within machine ratings). See ESB 750 regarding disturbances and capacitor installation.*
 - c. *Inverter-based systems such as Photovoltaic (PV) Systems are limited in aggregate to 500kVA on 4 or 5kV and in aggregate of large units 500kVA and above up to 3.0MVA on 15kV class systems (this is in addition to small (e.g. residential rooftop) PV until aggregate of these exceeds 500kVA). Operating issues on EPS voltage regulation occur from the effects of cloud transients on large PV systems.*
 - d. *Limits for 25kV and 38kV distribution class systems in Rhode Island are determined by the Company on a case-by-case basis.*
 - e. *On single-phase radial distribution systems, generators over 50kVA may require three-phase service. These situations will be determined by the Company on a case-by-case basis.*
7. Connecting customer generation to the **low voltage network** poses some unique issues for the Company; see Section 3.0 above. The generation can cause the power flow on network feeders to shift (i.e., reverse) causing network protectors within the network system to trip open. No synchronous generators are permitted for interconnection to the Company's secondary voltage network systems. Small induction and inverter-based generators are considered on the secondary voltage network systems on a case-by-case basis.
 8. Connection of distributed generators on the **spot networks** is only permitted if the secondary bus is energized by more than 50% of the installed network protectors.
 9. From Table 4.6-1, DG facilities ranging in size from 750kVA to 2.8MVA at 4 or 5kV class or from 2.5MVA to 9.0MVA at 15kV class, and installed on non-network systems are considered for connection to express radial distribution feeders since the light load condition on the existing feeders may not meet the acceptable norm to avoid islanding (i.e., one third of the feeder's all time light load must be greater than the aggregate nameplate distributed generation MW ratings). The EPS substation bus voltage regulation, transformer capacity, and high voltage side protection may be impacted by large DG systems and the Company may specify interconnection to a higher voltage EPS, which allows for continued growth of small DG on the Company's Distribution EPS (e.g. residential solar). These issues refer to "DG saturation" such that it becomes technically infeasible to operate on a single distribution feeder. The Company will identify DG saturation in screening and feasibility reviews and in the results of impact studies for DG applications. Studies will be more complex and accommodating interconnections will likely require more involved infrastructure development, costs, and duration to construct.
 10. Because of the severe safety and potential equipment damage issues associated with feeding power into a deenergized distribution system, a major design consideration of any customer generator installation is that THE GENERATOR SHALL NOT ENERGIZE A DE-ENERGIZED COMPANY CIRCUIT. The protection system shall be designed with interlocks and proper protective functions to ensure that there is proper voltage, frequency and phase angle conditions between the Company's Distribution EPS before the generator is permitted to parallel. Because of the potential interference with reclosing on radial and automatic sectionalizing feeders and/or restoration operations on the utility system, AUTOMATIC RECLOSING OF THE CUSTOMER'S INTERTIE CIRCUIT BREAKER IS NOT PERMITTED. The only exceptions that allow a unit to automatically reconnect are certain inverter-based generation systems as permitted by the RI SCDG.
 11. The Company's distribution substations are subject to fault duty limitations. Adding generation to the Company Distribution EPS increases the amount of fault current imposed on the substations and equipment on the feeder(s). Exceeding the fault duties at the substations and on the feeder(s) as a result of DG facilities will not be permitted and alternate methods of interconnection shall be explored where this limit has been reached.

12. Multiple service facilities may be supplied to the Customer from a Company Distribution EPS. These service installations may be either dual primary switchgear or dual secondary transformers. To assure that the reliability and proper protection are maintained in these multiple service facilities, the Customer is not permitted to:

- Parallel secondary services from a common facility.
- Parallel secondary facilities supplied from separate locations.
- Exceed the ampacity rating of any service facility.
- Create an unbalanced loading condition between phases of a service.

The interconnection of multiple services above 600 volts shall be specified by the Company within the Company's operating practices and electric service requirements to ensure safety to the public, to Company employees, and to the Customer.

5.0 General Design and Operating Requirements

From the perspective of interconnection, there are three main types of customer generation systems that interface to the Company's Distribution EPS. These include:

- Induction Generators
- Static Power Converters (inverter-based)
- Synchronous Generators

Each type has its own specific characteristics regarding synchronization equipment, protective functions, starting practices, and electrical operating behavior. There may also be additional specific requirements that may be identified as part of any Impact or Detailed Study that is performed for a specific location.

5.1 Applicable Codes, Standards, and Guidelines

1. The Customer's DG facility shall conform to the latest revision of all local, state and federal codes and national standards that apply. Specific standards applicable to this bulletin include, but are not limited to:
 - Institute of Electrical and Electronics Engineers (IEEE) Std. 1547 "Standard for Distributed Resources Interconnected with Electric Power Systems"
 - Underwriters Laboratories (UL) Std. 1741 "Inverters, Converters and Charge Controllers for Use in Independent Power Systems"
 - NFPA 70 "National Electrical Code" (NEC)
 - NFPA 70B "Recommended Practice for Electrical Equipment Maintenance"
 - NFPA 70E "Standard for Electrical Safety in the Workplace"
 - NETA-MTS "Maintenance Testing Specifications for Electrical Power Distribution Equipment and Systems"
2. The Customer's DG facility shall also conform to any applicable requirements of the Rhode Island DPU and any local, state, federal and/or other agencies from which a review, approval, or a permit is required.
 - The minimum "fall zone" clearance of wind turbine generators (WTG) shall be in accordance with the local governmental authority having jurisdiction (AHJ) and in any case, shall not be less than 125% of maximum WTG height measured horizontally to the Company's overhead distribution lines.
3. The Customer shall comply with the appropriate Company ESB or tariff requirements, which cover details for the Customer's electric service installation. These include:
 - **ESB 750** - Specifications for Electrical Installations
 - **ESB 751** - General Requirements Above 600-volt Service (*under development*)
 - **ESB 752** - Service Above 15,000 volts
 - **ESB 753** - Primary Meter Pole

- **ESB 754** - Outdoor Pad Mounted or Vault Enclosed Single and Three Phase Transformer
- **ESB 758** - Primary Service to Metal Enclosed Gear
- **R.I.P.U.C. 2078** - The Narragansett Electric Company Standards for Connecting Distributed Generation (RI SCDG)
- **R.I.P.U.C. 2040** - The Narragansett Electric Company Terms and Conditions for Distribution Service

Refer to **Exhibits 5** and **6** and **Figures 1** through **4** for information when submitting single-line diagrams to the Company's TSES department (electronic mail address: Distributed.Generation@nationalgrid.com).

5.2 Definitions

See the **RI SCDG** for definitions of special terms.

5.3 General Criteria

The interconnection of all parallel generators requires safeguards for synchronization and back feed situations in accordance with the RI SCDG. Each specific connection must be studied with respect to size, type, and the nature of the Company's Distribution EPS at the POI. Only the results of a specific study can indicate the suitability of a given generator connection to the Company's Distribution EPS and its possible economic viability. See the **RI SCDG** for detailed requirements.

5.3.1 Single Phase

Single phase parallel generator connections to Company Distribution EPS circuits under 600 volts present power quality and phase balance challenges. Single phase connections shall have these minimum characteristics:

- Nameplate rating of a single generator or group of generators equal to or less than 50kVA (see Note "e" to Table 4.6-1).
- Configured as a three-wire, line-to-line with neutral, or line-to-neutral with adequate load balance.
- A dedicated service lateral with a dedicated transformer, when required by the Company.

5.3.2 Three Phase

Three phase connections are required in all other instances.

5.3.3 Phase Balance

The Customer's DG facility shall permit equal current in each phase conductor at the service point. Voltage unbalance resulting from unbalanced currents shall not exceed 2% and shall not cause objectionable effects upon or interfere with the operation of the Company's facilities and service to others. This criterion shall be met with and without generation.

5.3.4 Neutral Stabilization and Grounding

Where the Customer is served from a Company four-wire multi-grounded neutral distribution circuit, adequate grounding must be provided to ensure neutral stability during accidental isolation of the line from the main system. This may require an additional ground source. Adequate grounding can be provided either by the use of wye-delta main power transformer (see Section 5.5) or by installing an appropriate grounding transformer. The effects of such grounding on the Company's ground-relay sensitivity shall be limited.

As a minimum, the Customer's generation equipment shall be grounded in accordance with the latest requirements of the National Electrical Code (NEC). For specific installations, refer to the applicable sections of this document and the Company's ESB 750. The Company requires ground protection on any system that can be a generation

source and to protect transformers that can be paralleled and supplied from two sources. When generator tripping is needed to sense ground faults on the Company's Distribution EPS:

- The winding arrangement of the Customer's DG facility transformer shall be such that the Company's system remains effectively grounded (see Section 5.5.3).
- The Company may require that the grounding impedance be limited to the highest value suitable for neutral stabilization (see Section 5.7.2), or to limit generator ground fault contributions (see Section 5.7.5).
- A "zero-sequence" voltage or "3V₀" scheme will be required on the primary side of a delta primary wound transformer supplying the DG facility; see **Figure 4**.

5.4 Service Equipment and Revenue Metering

5.4.1 Service Equipment Requirements

1. The Customer shall provide service entrance equipment as a part of their installation; see the Company's ESB 750. The Customer's service equipment shall be rated, at a minimum, for the maximum fault current available from the Company Distribution EPS and their own contribution from the generator(s), motors, etc.
2. At the service entrance equipment, the Customer shall have a permanent directory plaque to indicate all electric sources and the Generator Disconnect location(s) on their premise according to the NEC.
3. For large DG Customers with generation systems equal to or greater than 500kW, refer to the typical primary overhead service configuration requirements in **Exhibit 7**. At the Company's discretion the Company reserves the right to require an automatic three-phase interrupting device at the PCC for systems 250kW and above.

5.4.2 Company Revenue Metering Requirements

1. The Company will specify the location and arrangement of all equipment required for the revenue metering of the Customer's service and DG facility. Reference the Company's ESB 750, Section 7 for additional information and requirements. The Company's electricity tariff, R.I.P.U.C. 2099, describes qualifications for net metering.
2. An analog/POTS (Plain Old Telephone Service) telecommunications line to each Company-owned revenue meter location shall be provided by the Customer. The telephone line shall be capable of direct inward dial without human intervention or interference from other devices such as fax machines, etc.

5.5 Transformer

5.5.1 Purpose for DG Facility Interconnecting Transformer

A transformer at a DG facility serves three purposes. First, it enables proper voltage matching between the generator and the utility connection. Second, it acts as a buffer to limit any current contribution from the DG facility in the event of a short circuit on the electric system. Third, it can ensure effective grounding of the utility circuit when the DG is exporting power.

5.5.2 Secondary Served DG Customers

Where the Company provides secondary service, the Company's transformer is an equipment standard for service delivery voltages; see Section 3 in **ESB 750**. Non-standard transformers are not provided by the Company. The Company will determine when dedicated services and a dedicated transformer are required in order to reduce the impact on other adjacent customers. The need for a dedicated transformer(s) may be determined at any point in the generator's life cycle. If a dedicated transformer(s) is required, the Customer will be advised by the Company in writing. The cost of the transformer(s) will be the responsibility of the Customer according to R.I.P.U.C. 2040 and as permitted by the **RI SCDG**. DG projects need to be aware that the distribution EPS at rural locations will have single-phase loads on the feeders where phase impedance is typically unbalanced.

5.5.3 Primary and Higher Voltage Served DG Customers

The Company reserves the right to specify the winding connections for the Customer's "step-up" transformer between the Company's delivery point and the Customer's DG facility's output voltage as well as whether it is to be grounded or ungrounded. The Customer shall provide their interface "step-up" transformer's specifications and ratings for the Company's review in the impact and detailed studies.

5.5.3.1 Effectively Grounded, Four-wire Multi-grounded 3-phase Wye EPS:

The Company requires that all interface transformers be configured to have a wye connected primary winding with a fully insulated neutral, and the secondary winding to have a delta connection.

- If infeasible, an alternative that is subject to Company acceptance review is a primary wye grounded - secondary wye grounded transformer requiring a grounded source permitted under specified conditions.
- Any DG or aggregate DG below 500kW in a Customer's facility may be permitted to utilize a primary delta - secondary wye grounded transformer.
- Where any DG or aggregate DG is 500kW or greater in a Customer's facility, ungrounded transformers (i.e. primary delta or Yg-Yg with ungrounded source) are not permitted on any Company-owned effectively grounded, four-wire multi-grounded 3-phase wye circuits.

5.5.3.2 Not Effectively Grounded, Three-wire 3-phase EPS:

The Company only allows the connection of delta primary interface transformers on three-wire not effectively grounded 3-phase primary and high voltage circuits. Refer to Section 5.3.4 for grounding requirements such that the generator does not contribute to line-ground faults on the Company's EPS.

5.6 Manual Generator Disconnect Switch

1. According to the **RI SCDG**, inverter-based systems 25 kW and below are not required to have a separate disconnect if the unit has a disconnecting means integrated into the design and meets the requirements of the National Electrical Code (NEC).
2. For those projects requiring a disconnect switch (or comparable device mutually agreed upon by the Company and the Customer) at the point of DG facility interconnection that can be opened for isolation, these isolation devices shall be rated to interrupt the maximum generator output; meet applicable Underwriters Laboratories (UL), American National Standards Institute (ANSI), and IEEE standards; and shall be installed to meet the NEC and all applicable local, state, and federal codes.
3. The Customer's DG facility shall have an electrical load break disconnect switch accessible at all times to the Company to electrically isolate the Company's Distribution EPS from the Customer's generator facilities.
4. In accordance with the Company's safety rules and practices, this isolation device must be used to establish a visually open, working clearance boundary when performing maintenance and repair work. The designated generator disconnect also must be accessible and lockable in the open position and have provisions for both Company and Customer padlocks and be capable of being tagged and grounded on the Company side by Company personnel.
5. The visible generator disconnect switch shall be a gang-operated, blade-type switch (knife switch) meeting the requirements of the NEC and nationally recognized product standards. Pull-out switches commonly used in air-conditioning units and spas are not permitted for this application. The visible break requirement can be met by opening the enclosure to observe the contact separation. The Company shall exercise such right in accordance with Section 7.0 of the **RI SCDG**.
6. The connection of the disconnect switch shall have the line connection (i.e., jaw side) of the switch made to the utility source.

7. Additionally, the Customer is solely responsible for the maintenance of all fuses in fused, blade-type disconnect switches.
8. This disconnect device shall be identified by a permanent sign as required by the NEC and the **RI SCDG**.
9. For 4 or 5 or 15kV class interconnections, the DG Customer shall use a lockable, 15kV, 3-phase, gang-operated disconnect switch at the PCC. The DG Customer shall provide the Company with 24-hour/7-day unlimited access and control of this isolation switch.

5.7 Protective Device Equipment

5.7.1 Protection Requirements

All DG facilities shall meet performance requirements set forth by Section 4.2.3 in the RI SCDG. DG types of interconnection are categorized as either Group 1 “Facilities Qualified for Simplified Interconnection” or Group 2 “All Facilities Not Qualified for Simplified Interconnection” according to the **RI SCDG**. The Under Frequency relays for the Group 2 DG facilities shall not trip at frequencies higher than the curve provided for the “Eastern Interconnection Generator Tripping” in Figure 1 of the PRC-006-NPCC-1 Automatic Underfrequency Load Shedding criteria specified in the **RI SCDG**.

The DG Customer’s interconnection system shall have the capability to withstand voltage and current surges in accordance with the environments defined in the latest IEEE Standard C62.41.2 or IEEE Standard C37.90.1 as applicable.

5.7.2 Interconnection Interrupting Device

An interconnection interrupting device such as a circuit breaker shall be installed on the high voltage side of the interface transformer to isolate the DG facility from the Company’s EPS. If there is more than one interface transformer, this requirement applies to each one individually. The interconnection interrupting device shall be capable of interrupting the current produced when the DG facility is connected out of phase with the Company’s EPS.

5.7.3 Interconnection Transformer Configuration

In order to avoid Over Voltage (OV) on the distribution customers, it is National Grid’s policy that any Distributed Generator equal or above 500kW connected to a four wire distribution feeder should provide an effectively grounded system with respect to the Company’s EPS; see Sections 5.3.4 and 5.5 for grounding and transformer requirements. Contributing to the faults on the Company’s four-wire distribution EPS can desensitize the relays at the Company’s substation. Hence, it is required that the DG Customer provide a fully insulated neutral bushing for the primary wye winding of the step-up transformer and install a fault current limiting grounding reactor to limit the fault current to 3 times the generator rating. The grounding reactor shall not violate the effectively grounded system requirements. The inductive value of the reactor will be specified by the Company.

5.7.4 Instrument Transformers for Protective Device Relays

5.7.4.1 Current Transformers (“CT”)

CT ratios and accuracy classes shall be chosen such that secondary current is less than 5 amperes normal operation, 100 amperes under maximum fault condition and transformation errors are consistent with Company practices.

5.7.4.2 Voltage Transformers (“VT”) and Connections

See Sections 5.3.4 and 5.5 for transformer requirements. The DG facility shall be equipped with a direct voltage connection or a VT, connected in accordance with the Company’s requirements. The DG Customer is responsible for over voltage detection and the detection of line-to-ground faults on the primary and secondary sides of the step-up transformer as well as the Company’s EPS. For wye reactively grounded primary, delta secondary transformers, the DG Customer is required to install Yg-Yg VTs on their transformer secondary delta winding which will have the dual purpose to detect the voltage depression on the

faulted phase on low voltage line-to-ground faults to enable the operation of the 51C controlled overcurrent elements when faults occur on the Company EPS, as well as, detect the over voltage on the unfaulted phases for single phase-to-ground faults on the delta side of the step-up transformer. The use of Yg-Open Delta VTs will be considered by the Company on a case-by-case basis.

5.7.5 Synchronizing Devices

The DG Customer shall designate one or more Synchronizing Devices such as motorized breakers, contactor/breaker combinations, or a fused contactor (if mutually agreeable) to be used to connect the DG facility's generator to the Company's EPS. This Synchronizing Device could be a device other than the Interconnection Interrupting Device. The Synchronizing Device must be capable of interrupting the current produced when the Facility is connected out of phase with the Company's EPS.

5.7.6 Voltage Relays

Voltage relays shall be frequency compensated to provide a uniform response in the range of 40 to 70 Hz.

See Sections 5.3.4 and 5.5 where the DG Customer needs to install Yg/Yg instrument voltage transformers (VT) on their transformer secondary delta winding to detect overvoltage on unfaulted phases caused by single line-to-ground faults and provide voltage detection for a voltage controlled overcurrent (51C) element, which will trip the high side interrupting device.

5.7.7 Frequency Relays

Over and Under Frequency relays shall meet IEEE 1547 requirements. In addition, Group 2 DG facilities shall not be set above the "Eastern Interconnection Generator Tripping" curve of Figure 1 "Thresholds for Setting Underfrequency Trip Protection for Generators" in PRC-006-NPCC-1 "Automatic Underfrequency Load Shedding" criteria specified in the [RI SCDG](#).

5.7.8 Overcurrent Relays

See Sections 5.3.4 and 5.5 for transformer requirements. Overcurrent protection is required on the high side of the DG Customer's interface transformer to detect faults on the Company's EPS. Voltage controlled overcurrent elements (51C) are required for both phase and ground. These relays shall utilize voltage sensing via the Yg-Yg VTs on the DG Customer's transformer secondary delta winding to detect the single line-to-ground faults. The 51C elements shall trip the high side interrupting device.

5.7.9 Type Tested Equipment

Protective equipment that has been type tested and recognized under UL Standard 1741.1 by the [RI SCDG](#) for Group 1 DG facilities will be permitted. The Customer shall follow the testing requirements as outlined in the RI SCDG. **Exhibit 8** attached is a guide for the Company's witness for verifying a type tested net-metered DG installation's operational compliance.

5.7.10 Non-Type Tested Equipment

Protective equipment that has not been type tested per the [RI SCDG](#) and considered as Group 2 DG facilities will be permitted with the implementation of utility grade protective devices acceptable to the Company. The use of utility grade relays and relay redundancy is acceptable subject to prior Company review and acceptance. It is the Company's policy that any DG equal or above 500kW requires redundant relaying. At the Company's discretion the Company reserves the right to require redundant utility grade relays for systems 250kW and above. The relay specifications are classified as follows:

5.7.10.1 Photovoltaic (PV) Generation

IEEE 1547 compliant and UL-1741 certified inverters shall be equipped with an internal anti islanding scheme and active under voltage (27), over voltage (59),

zero sequence over voltage (59N), under frequency (81U) and over frequency (81O) relays.

5.7.10.1.1 Inverter-based PV Generator Equal or Above 500kW

The internal relays are considered as primary protection and the Company requires one additional utility grade relay to be installed as the secondary protection if the inverter-based PV size is equal or above 500kW. The 27, 59, 59N, 81U/O and voltage controlled over current 51C (Phase and Ground) elements shall be activated in the redundant relay. The utility grade relay failure alarm shall be wired to the Company-designated generator interrupting device. If the step-up transformer configuration is primary wye grounded - secondary delta, the over voltage element (59N) shall have the capability of detecting the Line-Ground faults on the delta side and trip the high side (utility side) interrupting device to separate the Company's EPS from the Line-Ground faults on the delta side (customer side) of the step-up transformer.

5.7.10.1.2 Inverter-based PV Generator Below 500kW

If the inverter is IEEE 1547 compliant and UL-1741 listed, the internal relays are considered as the only required protection and an additional utility grade relay is not necessary to be installed.

5.7.10.2 All Other Parallel Generation Equal or Above 500kW

For any generator equal or above 500kW, if the generator is equipped with internal relays with 27, 59, 59N and 81U/O relays, one utility grade relay is required to be installed as the secondary protection. Otherwise, two utility grade relays and one Company-designated interrupting device shall be installed to meet the protection requirements. The relay tripping scheme for the non-PV generators is the same as that of the inverter-based PV type.

5.7.10.3 Protective Relay Hard-Wire Requirement

Unless authorized otherwise by the Company, protective relays shall be hardwired to the device they are tripping. Further, interposing computer or programmable logic controller or the like is not permitted in the trip chain between the relay and the device being tripped.

The interconnecting relays shall be hardwired to the interconnecting interrupting device at the point of interconnection. There shall be no interposing programmable logic controller in the trip circuit.

Meter selector switches shall not be connected into the secondary circuits of current transformers used with protective relays specified by the Company.

5.7.10.4 Interconnection Interrupter Tripping and Protective Relay Supply

Interconnection interrupting devices shall have DC trip coils and tripping energy shall be derived from station batteries. Battery voltage, capacity specifications, and charging system provisions are subject to approval by the Company.

Control circuits associated with protective relays shall be DC powered from a battery and battery charger system. The battery shall be the sole source of tripping energy. Solid state relays shall be self-powered or DC powered from a battery and battery charger system.

If the DG facility uses a Company approved non-latching interconnection contactor, AC powered relaying may be permitted provided the relay as well as its method of application are fail-safe, meaning that if the relay fails or if the voltage and/or frequency of its AC power source deviate from the relay's design requirements for power, the relay or a separate fail-safe power monitoring relay acceptable to the Company will immediately trip the generator by opening the coil circuit of the interconnection contactor.

5.7.10.5 Use of Microprocessor Based Relays

1. Number of Relays Required:

Where relay performance may affect the operation of the Company's Distribution EPS at service voltages less than 15kV, a single microprocessor-based relay along with a Company approved scheme, where relay failure automatically trips the associated breaker(s), is acceptable. If the Customer decides not to use redundant microprocessor based protection systems on their other equipment, then appropriate action such as removing equipment from service shall be taken when a piece of equipment is no longer adequately protected.

2. Test Switches:

Microprocessor relays shall have ABB FT-1, or equivalent, test switches isolating all inputs and outputs of the relay.

Each relay designated by the Company as necessary to protect its electric system shall have its own test switch for AC and DC inputs that are associated with, and only with, that relay. DC test blades isolate the positive and negative DC for each input and output.

5.7.11 Utility Grade Protective Device Settings and Verification

5.7.11.1 Company-designated Relays and Customer Settings

The Company will review the Customer's settings and their calibration and test results of those relays that the Company's engineering department designates as being required to satisfy the Company protection practices. Any relay setting specified by the Company shall not be changed or modified at any time without the written consent of the Company.

5.7.11.2 Company Verification of Relay Testing

The Company requires a letter from the Customer stipulating that all Company-designated protective devices shall have:

- control wiring verified against the accepted design drawings, and,
- the calibration test performed satisfactorily according to the relay setting document of the accepted design.

The Company reserves the right to witness the Customer's functional test of the required devices, i.e., trip tests. This activity will normally be performed on a schedule as specified by Section 4.2.4 in the **RI SCDG**.

The Customer shall be responsible to specify the settings, calibrate, test, and maintain the balance of their equipment.

5.7.12 Anti-islanding

The Customer's generation facility will not be permitted to energize a de-energized Company circuit. The IEEE 1547 states that anti-islanding protection is required for parallel generation on the EPS. The Customer may propose various methods of anti-islanding protection of their own generation facility. It is the Customer's responsibility to demonstrate comprehensively the validity of such methods and the Company reserves the right to make the final determination as to which anti-islanding protection method is suitable. The use of direct transfer trip (DTT) is a definitive protection means for anti-islanding protection under good utility practice. Due to normal operation of Company switches, circuit breakers, and reclosers, the Customer's DG facility may be islanded with only a portion of the total feeder load. The Company evaluates anti-islanding protection for minimum load on the entire feeder and on the smallest switched feeder segment that may be connected to the DG.

Note: A Customer wishing to use a generation system as a stand-by or emergency generator shall submit details regarding an interlocking scheme, or transfer switch to prevent the energization of a de-energized Company circuit that complies with National Grid ESB 750, Section 11.

Direct Transfer Trip (DTT) may be specified for the following conditions:

5.7.12.1 Inverter-based Photovoltaic (PV) Generation

Relays at the Customer's DG facility and the Company's substation should be capable of detecting all four types of faults in the EPS. There may be conditions where intentional opening of the substation feeder breaker/recloser or in-line reclosers could cause the Customer's DG to island where the DG facility continues energizing the islanded feeder for more than 2 seconds. Those conditions can be classified as follows:

5.7.12.1.1 Load and Generation Match and Reactive Power Source in the Feeder Greater than 33% Generation

If there is a chance that minimum load on the feeder is close to the maximum generation such that the system frequency of the islanded feeder falls within acceptable range and the amount of reactive power being generated by the feeder capacitor banks in the islanded section of the feeder is above 33% of the inverter-based PV generation nameplate rating, there is a chance that the PV may create an island. Further transient analyses for dynamic conditions are required to determine the PV DG system's run-on time. In this case, DTT will be required to shut down the generator system in less than 2 seconds once the island forms. DTT may also be required for run-on time less than 2 seconds, if the analysis shows that damaging over-voltages could occur during that period.

5.7.12.1.2 Multiple Generators Containing PV on EPS

If the inverter-based PV generation is connected to a feeder that is already connected to reciprocating generators and the aggregate size of the reciprocating (i.e. synchronous or induction) generators is larger than 20% of the PV rating, a transient analysis for dynamic conditions is required to determine whether or not the island will form. The reciprocating generator can deactivate the inverter's anti-islanding scheme by tending to decelerate the rate of change of frequency due to the rotor inertia and absorbing reactive power for self excitation. The reactive power being injected by the inverters to perturb the frequency and detect the islanding condition may not be sufficient in the presence of the reciprocating generators.

5.7.12.2 All Other Parallel Generation Except PV Generators

If the minimum load on the feeder is above 3 times the maximum generation, DTT is not required. Otherwise, a transient analysis for dynamic conditions and a protective device coordination study are required to determine whether or not the islanding condition can form.

5.7.12.3 High-Speed Protection

The DG facility may be required to use high-speed protection if time-delayed protection would result in degradation in the existing sensitivity or speed of the protection systems on the Company's EPS.

5.7.12.4 DTT Installation Requirements

When DTT is specified for a parallel generation project, the Company will determine the requirements for equipment, installation, and communications media in the interconnection study. The communication option selected in the interconnection study must be agreed upon by all parties. The DG Customer shall bear the responsibility for cost and securing equipment on their property and contribute to the associated costs, including any recurring costs, for the Company's equipment in accordance with the applicable Company tariff.

5.7.13 Power Quality Compliance Verification

If during the study a DG interconnection project is identified as having the potential to cause power quality (PQ) effects on the EPS, then PQ monitoring shall be installed by

the Company or Company-accepted third party PQ testing company to verify power quality with and without generation. Third party PQ test methods and results may be submitted to the Company for review and acceptance. These verification tests shall include, at a minimum, the following in accordance with the Company's electricity tariff, R.I.P.U.C. 2040 and the limits and cost responsibilities specified in the **RI SCDG**:

- Check service point voltage for any discernible voltage fluctuation.
- Check service point frequency for any discernible frequency fluctuation.
- Check service point power factor to ensure it is no less than 90% (leading or lagging).
- Check service point harmonic distortion to ensure limits specified in ESB 750 and the RI SCDG as applicable, are maintained. Current harmonic distortion shall not adversely affect voltage harmonic distortion, the Company Distribution EPS, or service to other customers.

6.0 OPERATING

6.1 Power Factor

The Customer's overall (leading or lagging) power factor at the service point shall not be less than 90% or that which is permitted at the PCC by the **RI SCDG**. Corrective equipment may be required; if so, refer to ESB 750.

6.2 Power Quality Monitoring

1. If disturbances on the EPS and/or to other customers are determined to originate from a Customer with DG, PQ monitoring shall be installed to verify power quality in accordance with the Company's electricity tariff, R.I.P.U.C. 2040.
2. **If any power quality concerns cannot be corrected, the Customer will not be permitted to continue generation until such concerns are resolved to the Company's satisfaction.**

6.3 Isolation

Pursuant to Section 7 in the **RI SCDG**, the Company reserves the right to have the Customer remove their generation from the Company Distribution EPS at any time upon the Company's request. Normally, such requests result from the need to facilitate maintenance, test, or repair of Company facilities. The Customer's generator disconnect switch may be opened by the Company (i.e., isolating the Customer's generating equipment), without prior notice to the Customer, for any of the following reasons:

- System emergency operations require such action.
- Company periodic checks of Customer's interfacing equipment reveal a hazardous condition.
- Generating equipment interferes with other customers or with the operation of the Company Distribution EPS.
- Protective device tampering.
- Parallel operation, other than for **RI SCDG** testing of type tested inverters, prior to Company approval to interconnect.
- Failure to make available records of verification tests and maintenance of the Customer's protective devices designated by the Company.

6.4 Energy Management System-Remote Terminal Unit (EMS-RTU)

For distributed generator (DG) facilities,

- Less than 1MW, if there is feeder selectivity operation, then the Company may require an EMS-RTU.
- 1MW or greater, the Company requires an EMS-RTU for status and control of the generator.

The required inputs from the RTU to the Company's EMS are as follows:

- Status of individual generator breakers
- Status of main or interconnect breaker at the point of common coupling (PCC)
- Three phase line current for each generator
- Three phase line current at the PCC with the Company
- Three phase line-to-line voltage for each generator
- Three phase line-to-line voltage at the PCC with the Company
- Output kW for each unit (+ delivered to the Company, - received)
- Output kVAR for each unit (+ delivered to the Company, - received)
- Total MW (+ delivered, - received) at the PCC
- Total MVAR (+ delivered, - received) at the PCC

Exceptions to the above list may be considered by the Company on a case-by-case basis.

Note: The Company will provide an EMS-RTU point list for inputs required at the DG facility in the impact study, which will reflect the above input points.

The control portion would only involve the remote trip and block closing of the Customer's automated disconnect device designated by the Company. The block close function will be performed by control circuitry and is subject to Company acceptance review.

When a Company EMS-RTU is specified for a parallel generation project, the Company will determine the requirements for equipment, installation, and communications media in the interconnection study for the DG facility. The DG Customer will be responsible for all initial and recurring costs associated with MPLS communications for their RTU.

6.5 Balance of Customer Equipment

1. The Customer is responsible for performing all operating functions associated with their equipment and for maintaining all equipment under their ownership. The Customer shall arrange to have trained personnel available for the proper and safe operation of their equipment.
2. The Customer shall provide proper and continuous maintenance of all plant facilities; refer to National Fire Protection Association (NFPA) recommended practice NFPA 70B (and NFPA 73 where applicable) and other nationally recognized industry guides for guidance on electric equipment maintenance. See also the Company's ESB 755.
3. Where the Company is requested to supply demand pulse information (either analog or digital), its use is not intended for generator control.

7.0 REVISION HISTORY

<u>Version</u>	<u>Date</u>	<u>Description of Revision</u>
1.0	06/01/07	Initial version of new document superseding all previous revisions of ESB 756.
1.1	07/29/11	September 2010 ESB 750 Series Errata changes, formatting, and general editing.
2.0	08/06/12	Revised and formatted incorporating technical requirements of RI PUC 2078 Nov. 2011.

EXHIBITS ATTACHED

EXHIBIT 1: R.I.P.U.C. 2078 Tariff Figures 1 and 2 and Table 1

https://www.nationalgridus.com/non_html/StdscnnectDG2078_11-30-11.pdf

Figure 1 – Schematic of Rhode Island DG Interconnection Process

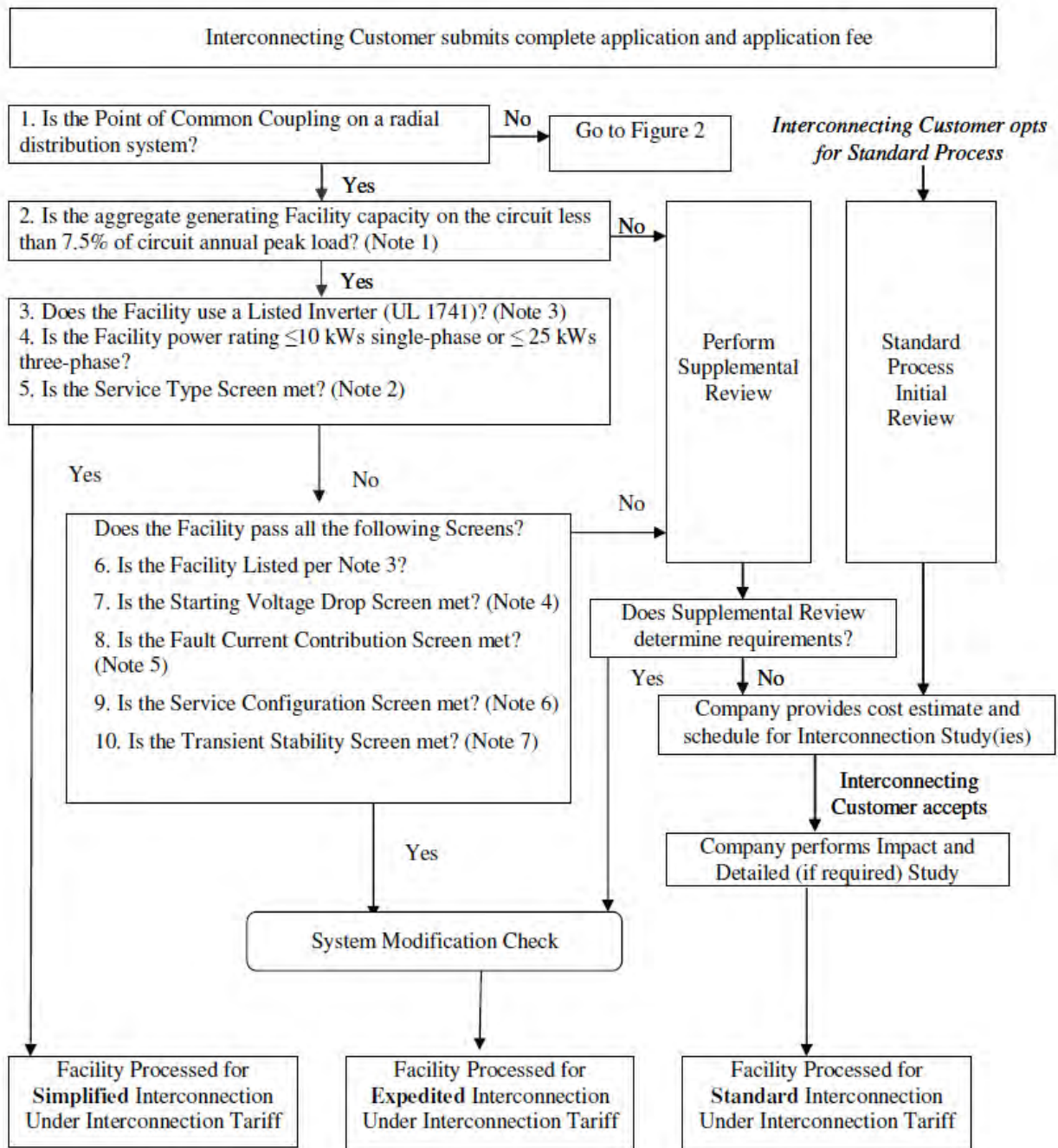

For explanatory notes accompanying Figure 1, see R.I.P.U.C. 2078, sheet 20.

Figure 2 – Simplified Interconnection to Networks

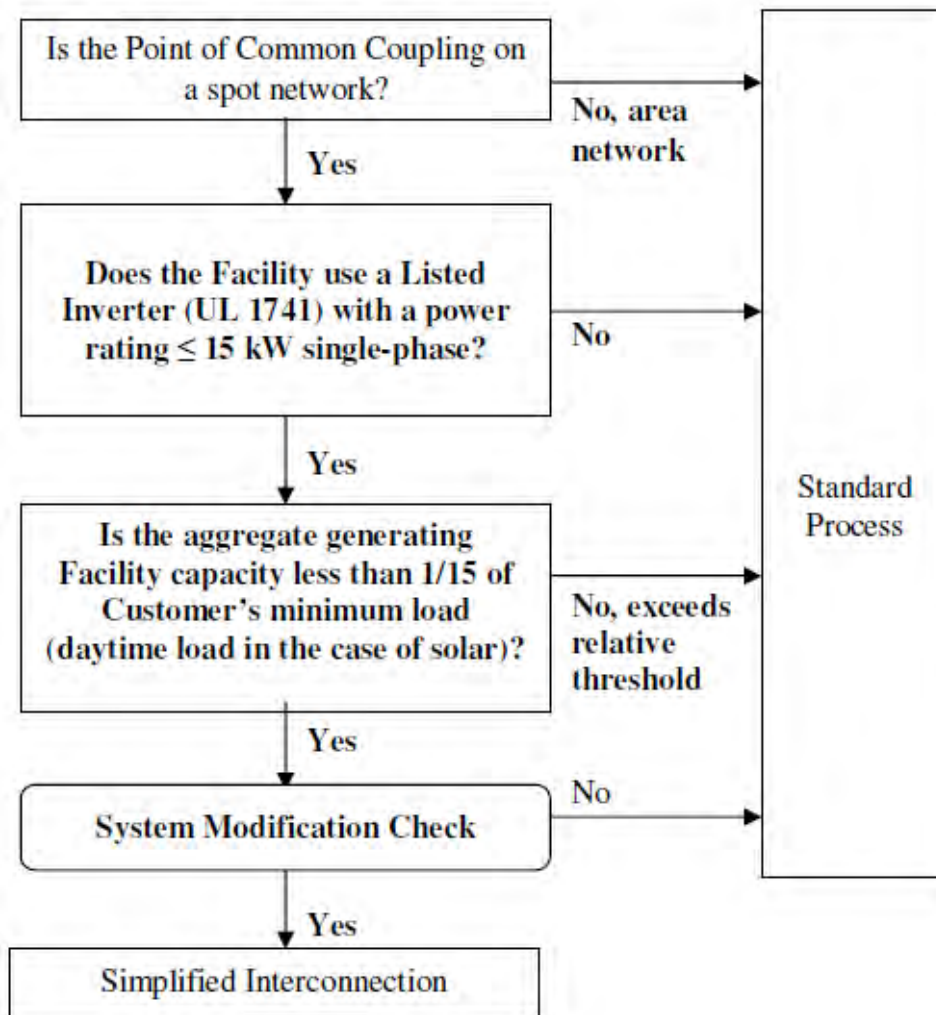

Table 1 - Time Frames (Note 1)

Review Process	Simplified	Expedited	Standard		Simplified Spot Network
Eligible Facilities	Listed Small Inverter	Listed DG	Any DG	Renewable DG	Listed Inverter ≤ 15 kW single-phase
Acknowledge receipt of Application	(3 days)	(3 days)	(3 days)	(3 days)	(3 days)
Review Application for completeness	10 days	10 days	10 days	10 days	10 days
Complete Review of all screens	10 days	25 days	n/a	n/a	Site review 30/90 days (Note 2)
Complete Supplemental Review (if needed)	n/a	20 days	n/a	n/a	n/a
Complete Standard Process Initial Review	n/a	n/a	20 days	20 days if Feasibility Study not requested	n/a
Send Follow-on Studies Cost/Agreement	n/a	n/a	5 days	5 days	n/a
Feasibility Study (if requested)	n/a	n/a	n/a	30 calendar days	n/a
Complete Impact Study or ISRDG (if requested)	n/a	n/a	55 days	The shorter of 55 days or 90 calendar days	n/a
Complete Detailed Study (if requested)	n/a	n/a	30 days	30 days	n/a
Send Executable Agreement (Note 3)	Done	10 days	15 days	15 days	Done (comparable to Simplified for radial)
Total Maximum Days (Note 4)	15 days	40/ 60 days (Note 5)	125/150 days (Note 6)	Varies depending on which studies are done (Note 6)	40/ 100 days
Notice/ Witness Test	< 1 day with 10 day notice or by mutual agreement	1-2 days with 10 day notice or by mutual agreement	By mutual agreement	By mutual agreement	1 day with 10- day notice or by mutual agreement

For explanatory notes accompanying Table 1, see R.I.P.U.C. 2078, sheet 25.

EXHIBIT 2: Company Requirements for Projects Not Eligible for the Simplified Process

These are Company items to be considered in the Customer's DG Project Schedule.

ID	Activity Description	RI SCDG § or ESB ref.
Project Definition & Conceptual Analysis Phase		
1	Customer R.I.P.U.C. 2078 Exhibit B Expedited/Standard Interconnection Application Form w/technical submittal & prelim. design received	3.2 or 3.3, Figure 1, Table 1
2	Company Preliminary Technical Assessment & cost estimate for Impact or Detailed Study	3.0, Table 2
3	Company R.I.P.U.C. 2078 Exhibit G or H Retail Connection Agreement executed with Customer	Exhibit G or H
4	Customer commits to Impact or Detailed Study and provides advance payment	5.0
Final Design Review Phase		
5	Company completes Impact or Detailed Study/Service Plan	3.2 or 3.3, Figure 1, Table 1
6	Customer commits to utility system modifications in Impact or Detailed Study/Service Plan and provides advance payment	4.0, 5.0
7	Customer's project schedule and final design & specifications received	4.0 – 8.0, ESB 750 & 752 or 753 or 754 or 758
8	Company reviews Customer's design & returns comments	4.0 – 8.0, ESB 752 or 753 or 754 or 758
Installation Progress Review Phase		
9	Customer's corrected design, test reports & settings received	4.0 – 8.0, ESB 752 or 753 or 754 or 758
10	Company reviews Customer's design & returns comments	4.0 – 8.0, ESB 752 or 753 or 754 or 758
11	Company field audit of Customer's installation progress	4.0 - 6.0
Installation Compliance Verification Phase		
12	Customer's advance notice of functional testing received	4.2.4, ESB 755
13	Electrical inspection certification approval received from municipal codes enforcement	ESB 750 & 752 or 753 or 754 or 758
14	Customer's acknowledgement of satisfactory wiring & relay calibration tests received	4.2.4, ESB 755
15	Company witness of Customer's functional testing	4.2.4, ESB 755
16	Company field audit of Customer's service connection	4.0 – 6.0, ESB 750 & 752 or 753 or 754 or 758
17	Customer resolves open items	ESB 750 & 752 or 753 or 754 or 758
Energization & Synchronization Phase		
18	Verification testing satisfied	4.2.4
19	Company's metering installation complete	8.0, ESB 750 & 752 or 753 or 754 or 758
20	Company's supply system interconnection complete	4.0, 5.0
21	Company review/acceptance of Customer's resolved open items	
22	Customer's Certificate of Completion received (and energization sequence plan for interconnections >600V)	3.2 or 3.3, ESB 755
23	Company proceeds with energization	
24	Customer is permitted to synchronize generation facility in parallel to the Company's supply	
Project Closeout Phase		
25	For interconnections >600V, remainder of Customer's protective system functional testing documented in an acknowledgement letter submitted to the Company within 10 business days after energization	ESB 755
26	Customer's as-built design drawings received within 90 days for interconnections >600V	ESB 750 § 1.7
27	Company reconciliation of project costs with Customer	When requested by Customer.

EXHIBIT 3: Reference Maps of National Grid Rhode Island Secondary Network EPS Areas

Narragansett Division

Pawtucket

Providence

[Maps are to be developed.]

National Grid customers in the downtown districts of Pawtucket and Providence can contact via E-mail addressed to Distributed.Generation@nationalgrid.com to determine if the proposed location is served in National Grid's Secondary Network area.

EXHIBIT 4: Distribution Secondary Grid Network Description

In Rhode Island, National Grid generally has two types of electrical distribution systems: radial and distribution secondary network systems. While the vast majority of customers are served from radial power systems, some customers in the downtown districts of Pawtucket and Providence in Rhode Island are served by distribution secondary network systems; see **Exhibit 3** for area maps. These systems are designed to meet the higher reliability needs, dense load levels, and limited space commonly encountered in urban areas.

A distribution secondary network system delivers electricity through a complex and integrated system of transformers and underground cables that are connected and operate in parallel. Power can flow in either direction on the secondary service delivery lines, commonly called secondary distribution lines. The loss of a single line or transformer in a secondary network system does not cause an interruption of power, unlike radial systems where there is only one line and one path for power to flow from the distribution substation to the customer's point of service. If a radial system experiences an outage, service is interrupted to the customers until repairs are completed; this is less likely to be the case in a distribution secondary network system.

In distribution secondary network systems, devices called "network protectors" are usually arranged to automatically connect its associated transformer to the network system when conditions are such that the transformer when connected will supply power to the network and to automatically disconnect the transformer from the network when power flows from the network to the transformer. The integration of DG into a distribution secondary network system may result in network protectors exceeding their original design criteria or nameplate ratings.

Example Distribution Secondary Grid Network Diagram

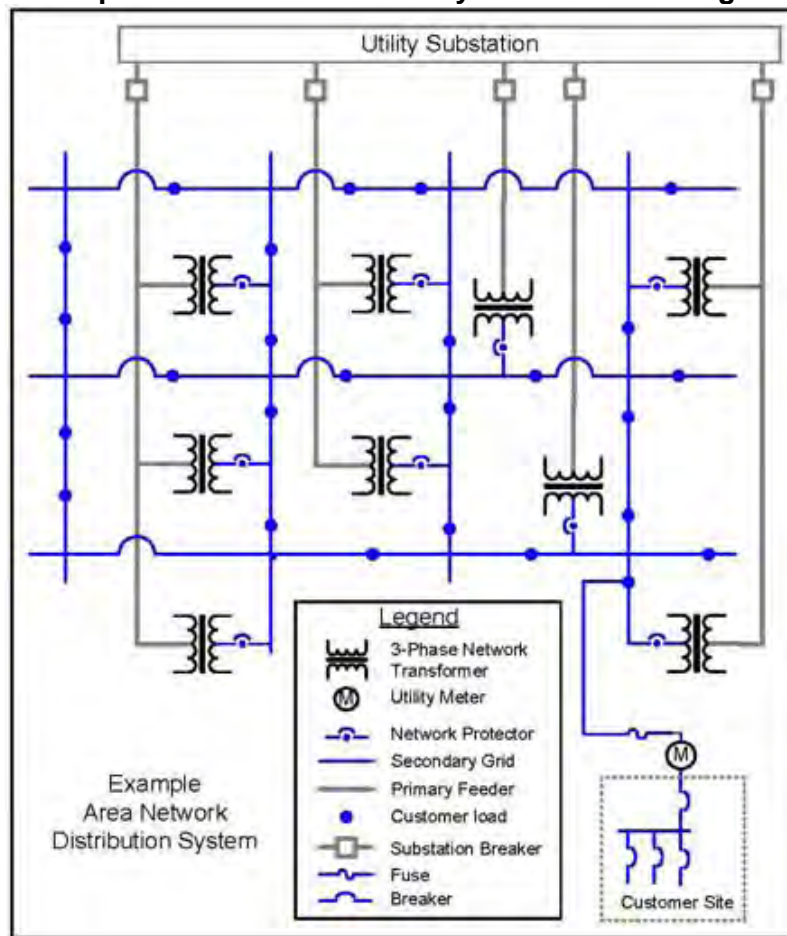

EXHIBIT 5: Recommended Guidelines for Residential and Commercial Single-line Diagram Submittals

Refer to **Figures 1** and **2** for typical illustrations.

1. Identify the project, Company's electric service order (ESO) number, location and submitter's name and address.
2. Indicate standard and any non-standard system voltages, number of phases, and frequency of the incoming circuit. Indicate wye and delta systems; show whether grounded or ungrounded.
3. Identify cable, conductors and conduit, the type and number. The Company is interested in how the power is getting from the service point to the protective equipment.
4. Identify wiring troughs and/or junction boxes where used.
5. Use standard symbols. See **NFPA 70B** or **IEEE Standard 141** for symbols in typical electrical single-line diagram development.
6. Identify the service equipment's switch and fuse or circuit breaker as to manufacturer, type, rating, catalog number, etc. Catalog cuts are not required for most major manufacturers. Service equipment must be able to safely interrupt the maximum available fault current from the supply; refer to **NEC** Articles 110 and 230.
7. Show billing meter trough or instrument transformers' cabinet (C.T. cabinet) in circuitry. Indicate source and load for the circuit. Refer to Section 7 in the Company's **ESB 750** for acceptable metering configurations.
8. Identify other protective devices and ratings. Include ratings in volts and amps, the interruption rating, and type and number of trip coils on circuit breakers. Also, note any special features of fuses (current limiting, dual element, etc.).
9. Identify ratios of current and potential transformers, taps to be used on multi-ratio transformers, and connection of dual ratio current transformers if used.
10. Identify any relays, if used, and their functions.
11. Show connections and ratings of power transformer windings for any to be used.
12. Identify Generator Disconnect and its ratings.

FIGURE 1: Sample Residential Photovoltaic Distributed Generator Installation – Single Phase, Net Metering

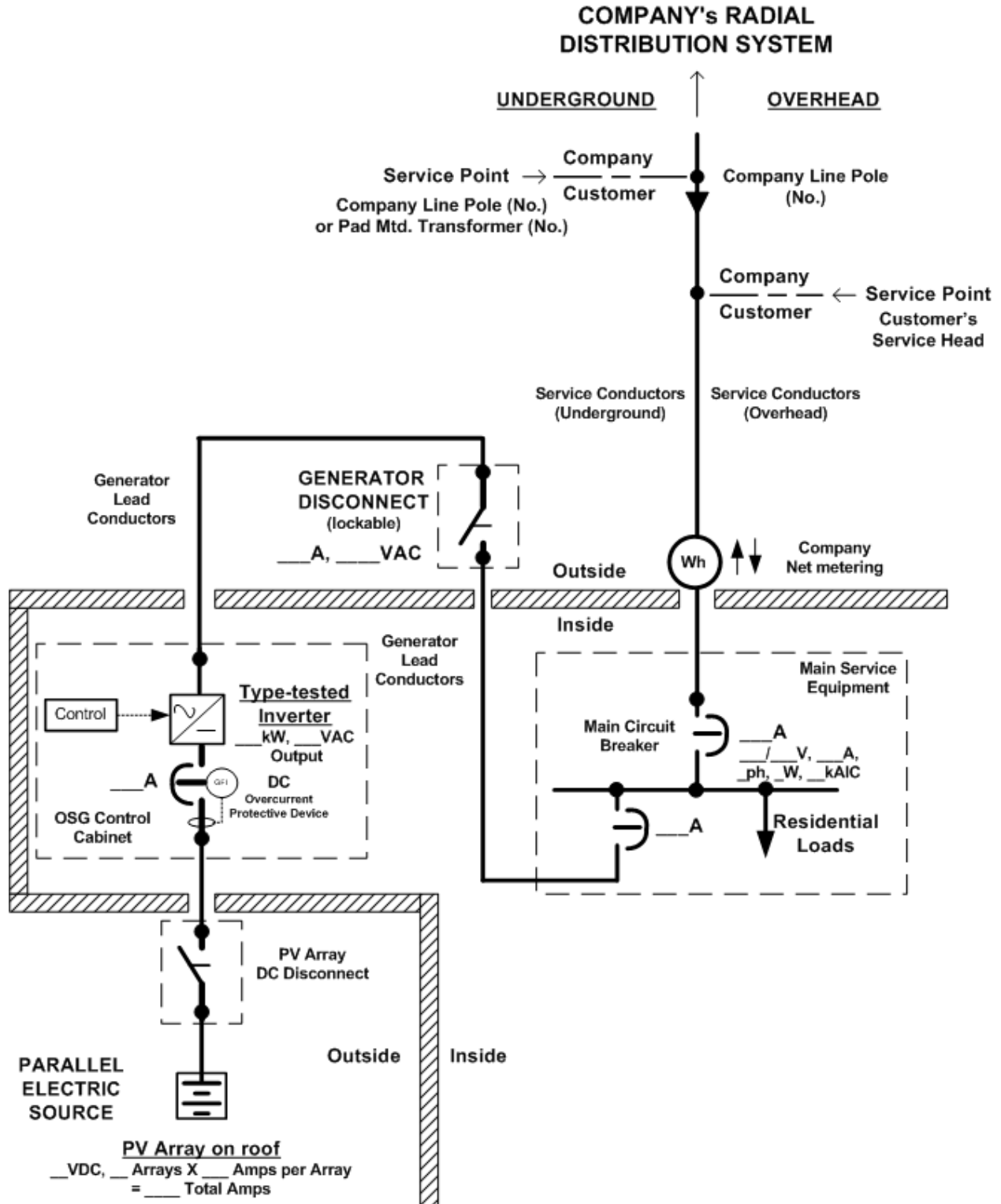

FIGURE 2: Sample Commercial Distributed Generator Installation

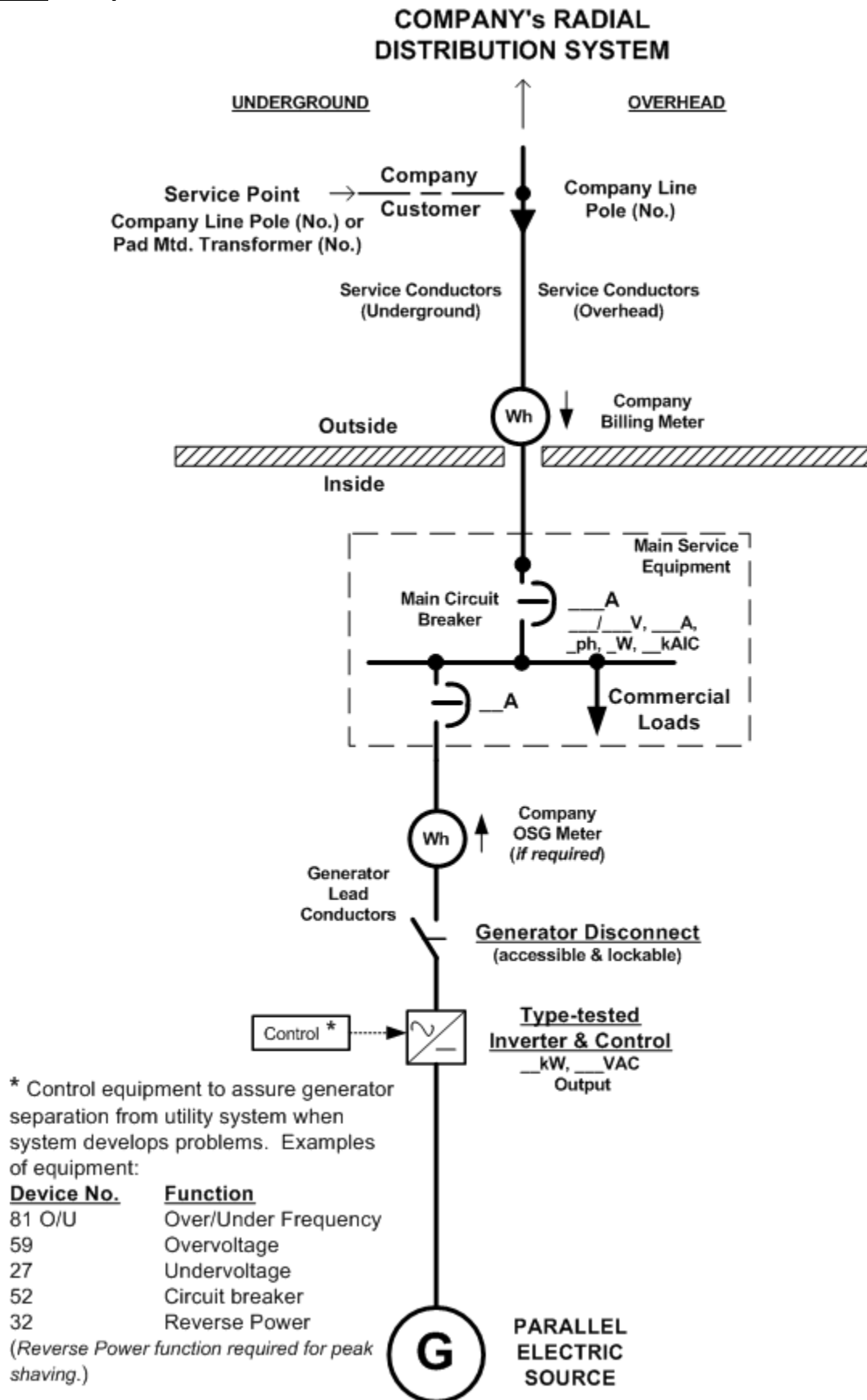

EXHIBIT 6: Recommended Guidelines for Functional Single-line Diagram Submittals

Refer to **Figures 3** and **4** for typical illustrations.

In addition to **Exhibit 5**:

13. On functional single-line diagram submittals, industry standard device numbers are necessary. Refer to the following List of Standard Device Numbers (See latest edition of **ANSI C 37.2**):

<u>Device Number</u>	<u>Function</u>
25	Synchronizing Device
27	Undervoltage Relay
32	Directional Power Relay
46	Negative Sequence Voltage
50	Instantaneous Overcurrent Relay
51	Phase Overcurrent Relay
51N	Neutral Overcurrent Relay
51V	Overcurrent Relay, voltage restraint
51C	Voltage controlled overcurrent
52	Breaker
52R	Recloser
59	Overvoltage Relay
59G	Neutral Voltage Relay
59N	Zero Sequence Voltage Relay
62	Time-delay Stopping or Opening Relay
64	Ground Protective Relay
81	Over and Under Frequency Relay
86	Locking - Out Relay
87	Differential Relay

FIGURE 3: Sample Functional Single-Line Diagram

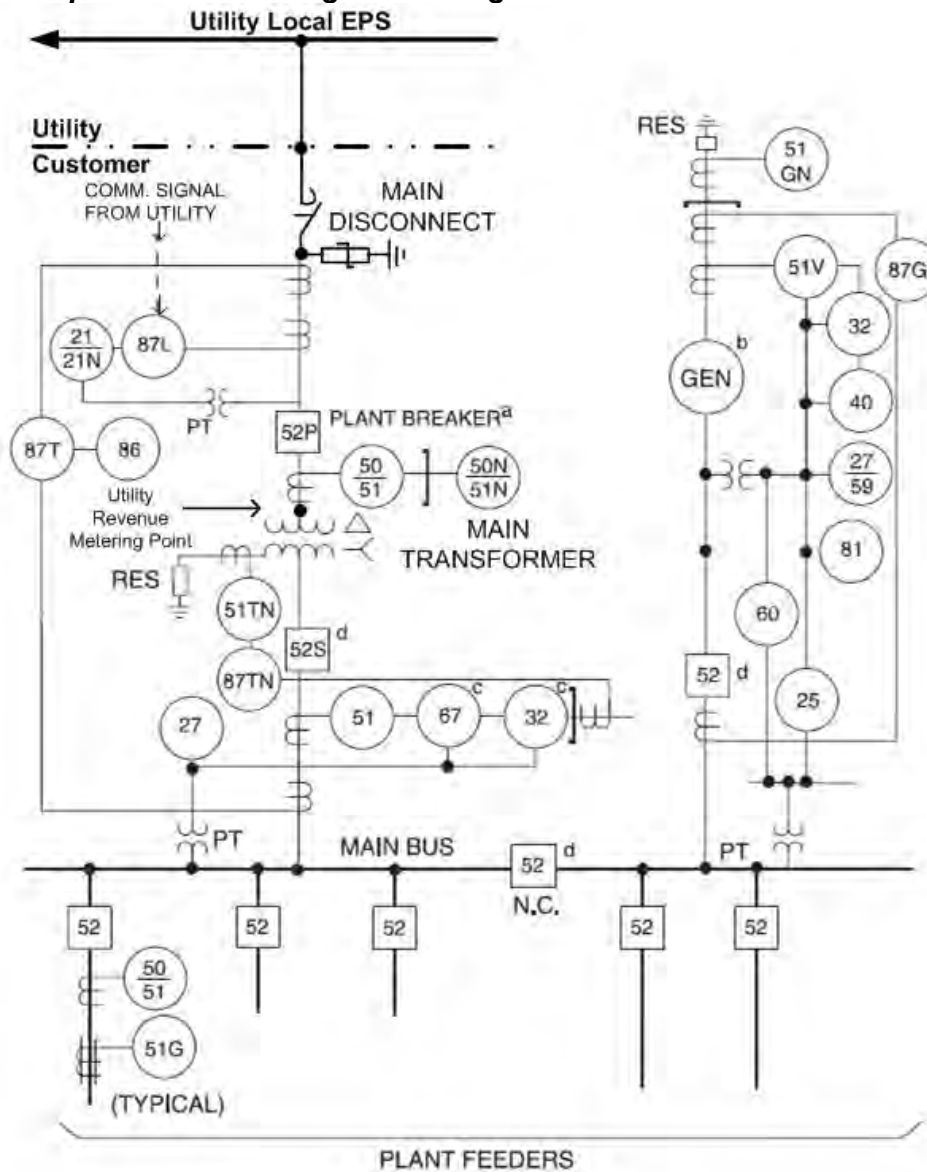

- NOTES:
- a. A fused interrupter switch may also be used instead of the breaker.
If fused interrupter is used, relaying associated with the transformer is not used.
 - b. In-plant generator for partial plant load and back-up.
 - c. Devices 67 and 32 are directional. Polarity of CTs and PTs must be verified.
 - d. Overcurrent and bus differential protection should be provided for the main, generator, and tie breakers, but protection is not shown here. See IEEE Std. C37.95 and C37.97.
Trip function lines not shown.
See IEEE Std. 242 Buff Book "Recommended Practice for Protection and Coordination of Industrial and Commercial Power Systems" for more information.

[TYPICAL ONLY]

FIGURE 4: Typical $3V_0$ Requirements for Local EPS Ground Fault Detection

The Company requires ground protection on any system that can be a generation source and to protect transformers that can be paralleled and supplied from two sources. In these cases, a “zero-sequence” voltage or “ $3V_0$ ” scheme will be required on the primary side of a delta primary wound transformer supplying the facility. Typically, the added relaying on the primary side of the transformer is a ground overvoltage device function 59N or 59G relay that can detect the presence of the single line-to-ground fault on the Local EPS. This is implemented by installing potential transformers (PTs) on the delta primary system as a source to a voltage sensing relay that would trip the primary side protective device. For a delta secondary wound transformer supplying the facility, the same “zero-sequence” voltage or “ $3V_0$ ” scheme is required on the secondary side but will open the transformer primary side protection.

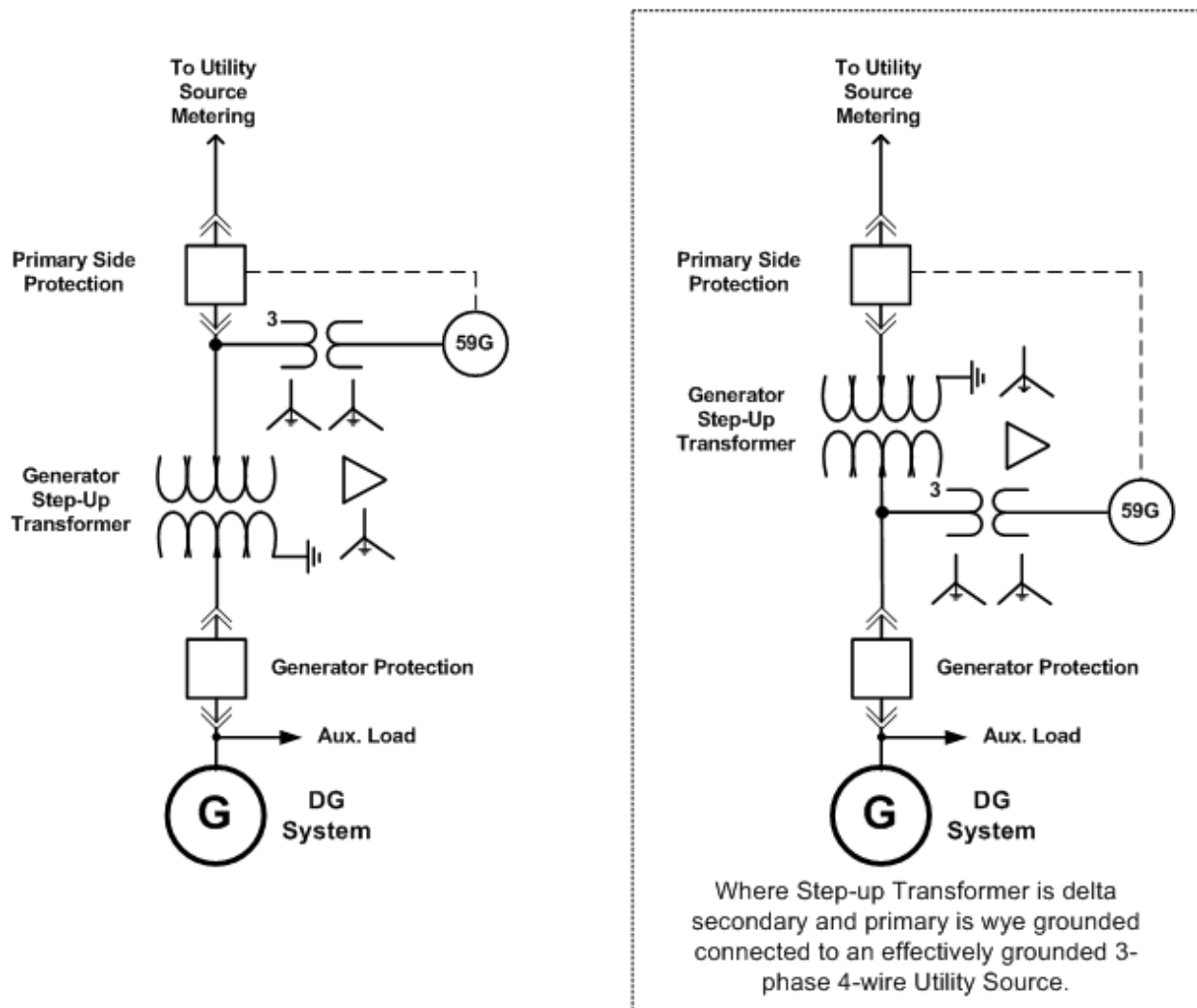

-- INFORMATION ONLY --
-- SIMPLIFIED DIAGRAMS NOT
ALL DETAILS SHOWN --

EXHIBIT 7: Typical Overhead Primary Service Configuration for Large DG Installations 500kW and Above

The DG Customer will be required to install a pole to the Company's specifications on which the Company will install cross arms and dead end the Company's primary service conductors. This point will be the physical Point of Common Coupling (PCC). At this pole the Customer-owned, 3-phase gang operated, Generator Disconnect switch can be installed and connected to the Company's primary service conductors by the DG Customer.

All Company-owned service lateral facilities and equipment on private property will require easements. These easements will be the responsibility of the DG Customer to obtain in accordance with the Company's specific electric service requirements; see [ESB 750](#).

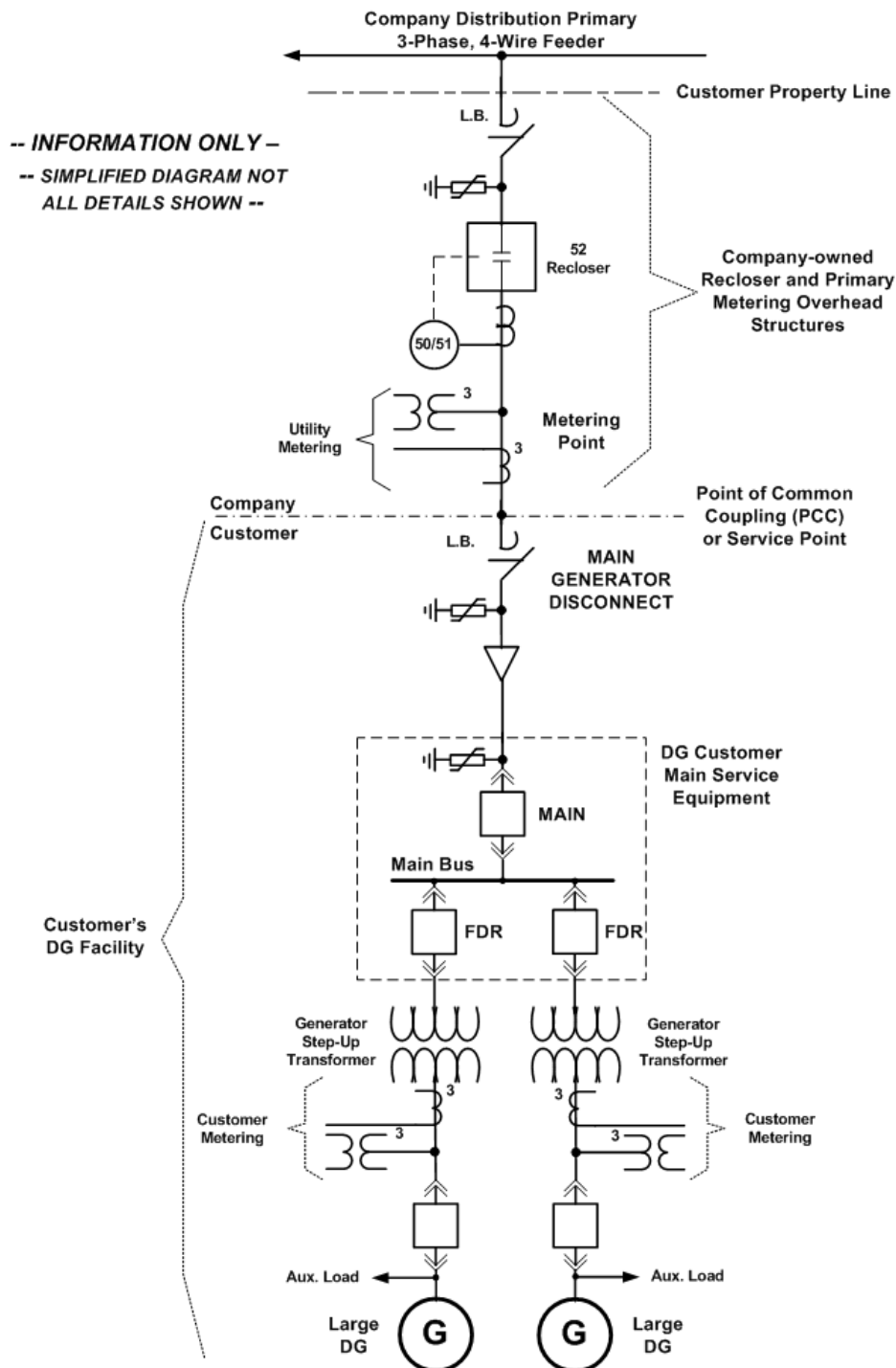

EXHIBIT 8: Net Metering Compliance Verification Checklist (Simplified Process)

Account Number: _____

Customer Name: _____ Last First Phone # _____
Work Phone # _____

Service Address: _____
Number Street Town/City Zip

Billing Address: _____
Number Street Town/City Zip

Qualified Installer: _____ License # _____ Phone # _____
Last First (if available) Cellular # _____

Address: _____ FAX # _____
Number Street Town/City Zip Pager # _____

✓ Verify One-Line Diagram (installed equipment)

_____ Inverter Model _____ or Intertie Multifunction Relay Model _____

_____ Software version _____

_____ Company billing meter s/n _____ Net-meter One Meter Option: YES ___ NO ___

_____ Inspection received? YES ___ Number _____ (attach copy of approval certificate)
NO ___, then stop and await inspection approval.

✓ Verify Plot Plan (equipment's location)

_____ "Generator Disconnect Switch" is at agreed location: YES ___ NO ___.

_____ "Generator Disconnect Switch" is labeled as such: YES ___ NO ___.

_____ Label is at meter location to identify location of Generator Disconnect: YES ___ NO ___.

✓ Verify DG System Is Operating (producing power)

_____ Verify "Generator Disconnect Switch" is Open.

_____ Verify voltage is zero volts on DG side of open "Generator Disconnect Switch": YES ___ NO ___.

_____ Close "Generator Disconnect Switch".

_____ Verify DG Inverter or Intertie Multifunction Relay alarms and voltage present on utility side of "Generator Disconnect Switch": YES ___ NO ___.

✓ Restoration of Utility Power Test

_____ Open "Generator Disconnect Switch", pause at least 1 to 2 minutes, then Close "Generator Disconnect Switch". Record time when "Generator Disconnect Switch" is closed: _____

_____ Record time when DG starts producing power: _____. Is the time between the "Generator Disconnect Switch" closure and when DG Inverter or Intertie Multifunction Relay permits synchronization to utility source greater than 5 minutes? YES ___ NO ___

✓ 24 Hour Telephone Number Contact

Name: _____ Number (____) - _____

Performed by: _____ signature: _____ Date: _____
Name (Customer's qualified installer.)

Witnessed by: _____ signature: _____ Date: _____
Name (Company witness.)

**Electric System Bulletin No. 756 Appendix E:
Requirements for Parallel Generation Connected To
National Grid Facilities in New Hampshire**

May 2007 version 1.1

ESB 756 Appendix E is part of the ESB 750 series



PREFACE

Electric System Bulletin 756 APPENDIX E covers Granite State Electric Company d/b/a National Grid Interconnection Policy, Customer-Owned Generating Facilities.

For net-metered generators sized less than 25kVA, see PUC900 at:

<http://www.puc.state.nh.us/Regulatory/Rules/PUC900%20Net%20Metering.pdf>

For all other generators, refer to the Massachusetts Department of Telecommunications and Energy (MDTE) document No. 1116-A, effective April 2, 2007 contained in Appendix C of this document.

(Note: The entire text of this document will be added to ESB 756 in a future revision.)

This is an appendix to ESB 756 and is available from the Company's web site and may be obtained:

- From the Internet at <http://www.nationalgridus.com/electricalspecifications>,
- Or in printed form by contacting either of the Call Centers in Massachusetts or New York (see inside cover of ESB 750). However, printed copies are not document controlled, so for the latest authorized version please refer to the Company's website.

1.0 REVISION HISTORY

<u>Version</u>	<u>Date</u>	<u>Description of Revision</u>
1.0	06/01/07	Initial version of new document superseding all previous revisions of ESB 756.
1.1	09/06/11	September 2010 ESB 750 Series Errata changes, formatting, and general editing.