new . york . independent . system . operator



NYISO
Emergency Demand Response
Program Manual

revised: 04 . 12 . 2001

1.0 Definitions and Acronyms

Capability Period - Six (6) month periods which are established as follows: (1) from May 1 through October 31 of each year (“Summer Capability Period”); and (2) from November 1 of each year through April 30 of the following year (“Winter Capability Period”).

Curtailed Customer Aggregator (or Aggregator) – An organization qualified as a CSP that enters into contracts with Demand Side Resources to either interrupt load or start up Local Generation under the EDRP.

Curtailed Program End Use Customer (EUC) – A retail end-user that qualified as a CSP and can either interrupt load or start up Local Generation under the EDRP.

Curtailed Services Provider (CSP) – A qualified provider that can produce real-time, verified reductions in NYCA Load of at least 100 kW, pursuant to the Emergency Demand Response Program (“EDRP”) and related ISO procedures. CSPs can be either an LSE, a Direct Customer, a Curtailed Customer Aggregator, or a Curtailed Program End Use Customer.

Customer Base Load (CBL) – Average hourly energy consumption as calculated in Section 6, used to determine the level of load curtailment provided.

Day-Ahead Zonal LBMP – The price (in \$/MWh) for combined energy, losses, and transmission congestion determined on an hourly basis in the day-ahead electricity market.

Demand Side Resources - Resources that result in the reduction of a Load in a responsive and measurable manner and within time limits established in the ISO Procedures.

EDRP – Emergency Demand Response Program, described in this manual.

EDRP Loads – Retail end-users that provide load reduction and have been registered through a CSP to participate in the Emergency Demand Response Program.

Emergency Condition - Any abnormal system condition as specified by the ISO that requires immediate automatic or manual action to prevent or limit loss of transmission facilities or Generators that could adversely affect the reliability of the electric system.

Emergency Generation - An electrical generator installed to handle emergency outages at a facility, for short periods of time.

In-Day Peak Hour Forecast – Forecasted morning and evening peak loads as determined by the NYISO Shift Supervisor or his assignee, used to evaluate total operating capacity.

Installed Capacity (ICAP) - A Generator or Load facility that complies with the requirements in the Reliability Rules and is capable of supplying and/or reducing the demand for energy in the New York Control Area for the purpose of ensuring that sufficient energy and capacity are available to meet reliability rules. The Installed Capacity requirements, established by the New York State Reliability Council, includes a margin of reserve in accordance with the Reliability Rules.

Interval Metering – An approved metering device which records electricity usage for each fifteen minute period during a billing period.

Load Bank - An electric resistance coil or similar device that creates an electric load which is used for testing generators under load.

Load Curtailment (or Reduction) - A reduction in energy usage at a retail end user's facility that is the result of the retail end user either reducing the energy consumed or operating an on-site generator.

Load Serving Entity (LSE) – Any entity, including a municipal electric system and an electric cooperative, authorized or required by law, regulatory authorization or requirement, agreement, or contractual obligation to supply Energy, Capacity and/or Ancillary Services to retail end users located within the NYCA, including NYISO Direct Customers.

Local Generator - A generator operated by or on behalf of loads offering load reductions pursuant to the Emergency Demand Response Program. Such generators are not synchronized to a utility's local distribution system or, if synchronized to the local distribution system, support a load that is equal to or in excess of the generator's capacity; *i.e.* when operating, the local generator supplies energy only to the end user whose load it is being operated to serve and does not supply energy to the distribution system. On-site generators that are base-loaded do not qualify for the EDRP.

Locational Based Marginal Price (LBMP) - The price of energy bought or sold in the LBMP Markets at a specific location or zone.

Meter Service Provider (MSP) - An entity that provides meter services, consisting of the installation, maintenance, testing and removal of meters and related equipment.

Meter Data Service Provider (MDSP) – An entity providing meter data services, consisting of meter reading, meter data translation and customer association, validation, editing and estimation.

New York Independent System Operator (NYISO) - Not for profit organization created to supply New York's electric power needs and to facilitate the power market equitably.

NYCA –The Control Area that is under the control of the NYISO which includes transmission facilities listed in the ISO/TO Agreement Appendices A-1 and A-2, as amended from time-to-time, and Generation located outside the NYS Power System that is subject to protocols which allow the ISO and other Control Area operator(s) to treat some or all of that Generation as though it were part of the NYS Power System.

NYISO Customer – An entity which has complied with the requirements contained in the ISO Services Tariff, including having signed a Service Agreement, and is qualified to utilize the Market Services and the Control Area Services provided by the NYISO under the ISO Services Tariff; provided, however, that a party taking services under the Tariff pursuant to an unsigned Service Agreement filed with the Commission by the NYISO shall be deemed a Customer.

NYISO Direct Customer – An entity which takes or provides service directly from or to the NYISO, and is responsible for bidding, scheduling, and billing functions for their facilities.

NYISO Limited Customer – An entity that joins the NYISO to participate in the EDRP; registration requirements are the same as for a NYISO Customer except that a Limited Customer:

- is not required to satisfy the financial assurance obligations imposed on Customers,
- their status as a Limited Customer expires at the end of the EDRP program, and
- voting privileges are waived with respect to the governance process.

All NYISO Customers meeting the eligibility criteria set forth in Section 3 qualify as Limited Customers, and may participate in the EDRP subject to the registration procedures defined in Section 4.

NYISO Services Tariff – The document that sets forth the provisions applicable to the services provided by the ISO related to its administration of competitive markets for the sale and purchase of Energy and Capacity and for the payments to Suppliers who provide Ancillary Services to the ISO in the ISO Administered Markets and provision of Control Area Services, including services related to ensuring the reliable operation of the NYS Power System.

NYS DEC – New York State Department of Environmental Conservation.

Operating Reserve Shortage – Failure to maintain the Minimum Operating Reserve Requirement as defined in Section 4.1.1 of the NYISO System Operating Procedures.

Real-Time Zonal LBMP – The price (in \$/MWh) for combined energy, losses, and transmission congestion determined on a roughly five-minute basis in the real-time electricity market.

Remote Metering - Metering equipment which allows for remote collection of metering data.

Special Case Resource - Loads capable of being interrupted upon demand, and distributed generators, rated 100 kW or higher, that are subject to special rules set forth in the NYISO Services Tariff, in order to facilitate their participation in the Installed Capacity market as Installed Capacity Suppliers.

Zone - One of eleven geographical areas located within the NYCA that is bounded by one or more of the fourteen New York State Interfaces. During the implementation of the LBMP Markets, all Loads located within the same Load Zone pay the same Day-Ahead LBMP and the same Real-Time LBMP for Energy purchased in those markets.

2.0 Program Summary

The *Emergency Demand Response Program* (EDRP) provides a mechanism for load reduction during emergency conditions, more specifically defined in this document, thereby facilitating the reliability of the New York State bulk power system.

Retail end users who agree to participate in the EDRP can be accommodated through one of four types of Curtailment Service Providers (CSPs):

- Load Serving Entities (LSEs), either that currently serving the load or another LSE,
- through NYISO-approved Curtailment Customer Aggregators
- as a Direct Customer of the NYISO
- as a NYISO-approved Curtailment Program End Use Customer

Curtailment Customer Aggregators and Curtailment Program End Use Customers must register with the NYISO as Limited Customers as defined in Section 4.0.

CSPs should be able to provide load reduction of at least 100 kW per Zone and be able to respond within two hours of emergency notification.

Participation in the EDRP is voluntary and no penalties attach if a CSP fails to respond to a NYISO notice to reduce load.

Retail end users participating in the EDRP may also participate in the NYISO's Special Case Resources Program if otherwise qualified.

CSPs will be given notice no less than two hours in advance of the time specified to reduce load, pursuant to NYISO emergency operations procedures. If the ISO activates the Emergency Demand Response Program for more than four hours, each CSP shall be paid the higher of \$500/MWh, or the zonal Real-Time LBMP per MWh of demand reduced, starting with the hour specified by the ISO as the starting time of the activation, or, in the event that the ISO specified that the demand reduction begin as soon as possible, starting with the hour that the CSP began its response.

If the ISO activates the EDRP for four hours or less, each CSP shall be paid as if the EDRP had been activated for four hours. Each CSP that reduces demand shall be paid the higher of \$500/MWh or the zonal Real-Time LBMP per MWh of demand reduced, for the duration of the ISO activation of the EDRP or for two hours whichever is greater, starting with the hour specified by the ISO as the starting time of the activation, or, in the event that the ISO specified that the demand reduction begin as soon as possible, starting with the hour that the CSP began its response. Each CSP shall be paid the zonal Real-Time LBMP per MWh of demand reduced for the remainder of the four hour minimum payment period, provided that a verified demand reduction was effectuated by the time specified in the ISO's notice.

A detailed explanation of payments can be found in Section 6.

The program will be effective May 1, 2001 and will continue through October 31, 2002. At the end of each Capability Period, the program will be evaluated and changes recommended as necessary.

3.0 Eligibility Criteria / Participant Qualification

3.1 Effective Period of the Program

The program begins on May 1, 2001, and will continue through October 31, 2002. At the end of each Capability Period (May-October and November-April), program performance will be evaluated to see if any rules and procedures need to be modified.

Entities wishing to participate may apply for entry into the program at any time. If you are also planning to qualify as a Special Case Resource you should review the rules and regulations that apply to Installed Capacity (ICAP) suppliers found in [1], or contact NYISO Market Relations.

3.2 Who Can Participate?

The EDRP allows wholesale electricity market participants to subscribe retail end users able to provide Load Reduction (Demand Side Resources) when called upon during emergency conditions. Wholesale market participants are grouped into four broad classes of *Curtailment Service Providers* (CSPs):

- *Load-Serving Entities* (LSEs) as defined in [2] that currently serve retail end users capable of load reduction, or an LSE that subscribes another LSE's load solely for the purpose of participating in the NYISO EDRP. LSEs may claim load reductions from their retail end users or the retail end users of another LSE. Load curtailment programs currently in place or under implementation may directly qualify for the EDRP (see 3.4 Restrictions below).
- *Direct Customers* of the NYISO as defined in [2] may claim their own load reductions.
- NYISO-approved *Curtailment Customer Aggregators* (Aggregators) of retail end users capable of load reduction. Aggregators may claim load reductions from Demand Side Resources with which they have a contractual arrangement. An Aggregator is required to join the NYISO as a NYISO Limited Customer.
- NYISO-approved *Curtailment Program End Use Customers* (EUC), end-use customers whose load is normally served by an LSE but who wish to participate directly with the NYISO solely for purposes of the EDRP. EUCs must be capable of reducing at least 100 kW of load. An EUC is required to join the NYISO as a NYISO Limited Customer.

Participation in the EDRP is voluntary; no penalties are imposed upon CSPs or Demand Side Resources for not responding to load reduction requests.

3.3 Minimum Qualifications for CSPs

To serve as a CSP, you must:

- 1) Be a NYISO Customer (in the case of LSEs and Direct Customers) or a NYISO Limited Customer (in the case of Aggregators and EUCs) of the NYISO and be able to pledge Load Reduction in the NYCA.
- 2) Be able to completely disconnect from the local distribution system and supply required load via local generators¹ or to reduce a measurable and verifiable portion of the load.
- 3) Be capable of reducing at least 100 kW of load per Zone.

¹ These generators either can be non-synchronized to the grid or synchronized to the grid with no net export to the grid while serving load.

- 4) Be capable of responding within two hours of notice from the NYISO.
- 5) Follow the registration procedures defined in Section 4 of this manual.
- 6) CSPs are required to provide hourly interval metering data to validate performance; specific metering requirements are given in Section 6 of this manual.

3.4 Restrictions

To participate in the program, an individual Demand Side Resource cannot subscribe the same metered load with more than one CSP.

Retail end users under a contract that prevents them from curtailing energy are prohibited from participating in the program. The NYISO will consult with the appropriate LSE and Electric Distribution Company to verify that the load to be reduced is not under any other specific contractual obligation that would prevent participation in the EDRP.

3.5 Requirements for Curtailment Customers With On-Site Generation

Owners of on-site and emergency generators including, but not limited to hospitals, data centers, office buildings, warehouses and industrial locations are eligible to participate in the EDRP. On-site generation will serve all or part of what otherwise would be NYISO load (i.e., the retail end user's specific load delivered from their LSE), thereby reducing the total NYISO load during declared emergencies. The requirements for participation are as follows:

- 1) The generator may operate non-synchronous or synchronous with the grid as long as there is no net electric export while serving the load.
- 2) Be capable of responding within 2 hours of a request to reduce load.
- 3) Must have an integrated hourly or permanent recording meter as described in Section 6.1, Metering Requirements.
- 4) Be capable of receiving notification from a Curtailment Service Provider (CSP).
- 5) Be compliant with the appropriate NYS DEC permitting / registration requirements.
- 6) Demand Side Resources that will use on-site generators to reduce load and that have Load Banks for testing purposes must ensure that the Load Bank is not operating during the hours required by the EDRP.

Nothing in the EDRP expands or reduces the rights or obligations a Local Generator may have to buy or sell energy into the wholesale market.

3.6 Compatibility with ICAP Special Case Resources

The EDRP pays for energy during times of emergency, but does not pay for capacity. The NYISO has a separate program called Special Case Resources (SCR) within the Installed Capacity (ICAP) market that pays for capacity. SCR is available to generators and load reduction providers that meet testing, metering and other requirements. The capacity payments under SCR and the EDRP energy payments are additive. While there are no penalties for non-performance as an EDRP provider, the SCR program will reduce future capacity payments if the NYISO calls for operation and the SCR does not perform. In the event that the NYISO activates SCR to reduce their consumption of energy in accordance with the criteria set forth in Section 5, the NYISO will activate the EDRP. See the ICAP Manual located at www.nyiso.com/markets/icapinfo.html for more details on SCR.

3.7 Compatibility with LSE-Sponsored Curtailment Programs

There are curtailment programs in New York State both currently in place and under development that are designed to help the local utility with distribution load management. Each program is aimed at enhancing the reliability of the local electric system during time of high usage or outages. The EDRP is designed to be compatible with these programs

Demand Side Resources may participate in both the EDRP and the Day-Ahead Demand Reduction Program (DADRP) offered by the NYISO. If an EDRP event is called and a Demand Side Resource is participating in both programs, payments will be made as follows:

- 1) If the Demand Side Resource has not had a demand reduction bid accepted in the Day-Ahead Market for the day of the EDRP event, demand reduction provided as a result of the EDRP event call will be paid in accordance with the rules set forth in this manual.
- 2) If the Demand Side Resource is responding to the schedule determined from the bid accepted in the Day-Ahead Market, payments will be made in accordance with the DADRP rules up to the demand reduction scheduled in the Day-Ahead Market. Additional verified demand reduction above that scheduled in the Day-Ahead Market will be paid in accordance with the rules set forth in this manual.

4.0 CSP Registration Procedures

To qualify as a Curtailment Service Provider (CSP) you must be an LSE, Direct Customer, Curtailment Customer Aggregator or Curtailment Program End Use Customer. The registration form is posted on the NYISO web site (www.nyiso.com) and included in Attachment A to this manual. The general requirements for each CSP class are as follows:

4.1 Load Serving Entities (LSE)

For LSE's that are enrolling a retail end user whose load is served by the LSE:

1. Complete Attachment A of this manual.
2. Register each Demand Side Resource with the NYISO after signing a contract using the EDRP Certification form provided in Attachment B of this manual.
3. By submitting the EDRP Certification Form, the LSE confirms that the load to be reduced is not under any specific contractual obligation that would prevent participation in the EDRP.

For LSE's that are enrolling a retail end user whose load is served by a different LSE:

1. Complete Attachment A of this manual.
2. Register each Demand Side Resource with the NYISO after signing a contract using the EDRP Certification form provided in Attachment B of this manual.
3. Within 2 days after receipt of the EDRP Certification Form, the NYISO will forward the registration to the appropriate LSE and Electric Distribution Company to confirm that the load to be reduced is not under any specific contractual obligation that would prevent participation in the EDRP.
4. The EDRP participant registration is deemed approved in 14 calendar days after notification is provided to the LSE unless the NYISO contacts the LSE via phone or e-mail to the contrary.

4.2 Direct Customers

Direct Customers of the NYISO should fill out Attachment A and one copy of Attachment B.

4.3 Curtailment Customer Aggregators

Curtailment Customer Aggregators are companies that work with owners of generation and load reduction to make it easier to participate in the NYISO Emergency Demand Response program. To register as a Curtailment Customer Aggregator, you must become at least a NYISO Limited Customer. If you are applying for NYISO Limited Customer status as a Curtailment Customer Aggregator and will only be a seller to the NYISO:

1. Complete Attachment A of this manual.
2. Complete Sections A, B, F, G, H, J and K of the NYISO Registration Packet, available at the NYISO website
3. Sign the Market Services Tariff.

4. Register each Demand Side Resource with the NYISO after signing a contract using the EDRP Certification form provided in Attachment B of this manual.
5. Within 2 days after receipt of the EDRP Certification Form, the NYISO will forward the registration to the appropriate LSE and Electric Distribution Company to confirm that the load to be reduced is not under any specific contractual obligation that would prevent participation in the EDRP.
6. The EDRP participant registration is deemed approved in 14 calendar days after notification is provided to the LSE unless the NYISO contacts the Curtailment Customer Aggregator via phone or e-mail to the contrary.

The application process can take up to 30 days.

4.4 Curtailment Program End Use Customer (EUC)

An EUC is any Local Generation owner or retail end user capable of interrupting load that can reduce at least 100kW in a zone and wants to participate in the EDRP directly with the NYISO. If you are applying for NYISO Limited Customer status as an EUC and will only be a seller to the NYISO:

1. Complete Attachment A of this manual.
2. Complete Sections A, B, F, G, H, J and K of the NYISO Registration Packet, available at the NYISO website
3. Sign the Market Services Tariff.
4. Register each Demand Side Resource with the NYISO after signing a contract using the EDRP Certification form provided in Attachment B of this manual.
5. Within 2 days after receipt of the EDRP Certification Form, the NYISO will forward the registration to the appropriate LSE and Electric Distribution Company to confirm that the load to be reduced is not under any specific contractual obligation that would prevent participation in the EDRP.
6. The EDRP participant registration is deemed approved in 14 calendar days after notification is provided to the LSE unless the NYISO contacts the EUC via phone or email to the contrary.

The application process can take up to 30 days.

5.0 Operating Mechanism / Implementation

5.1 When Will the Program be Called?

The EDRP is limited to when called by the NYISO as a part of the In-day Peak Hour Forecast response to an Operating Reserve Peak Forecast Shortage as defined in [3]. The EDRP will be called in conjunction with Special Case Resources.

The NYISO will invoke the EDRP as one of its emergency procedures in conjunction with the In-day Peak Hour Forecast response to an Operating Reserve Peak Forecast Shortage, as defined in [3], or in response to the Major Emergency state as defined in [4]. Day-ahead notice of a potential operating reserve shortage shall be provided to CSPs when possible. The program is intended to support the New York State power system during emergency periods and the NYISO reserves the right to use its discretion in calling upon EDRP resources to relieve system or zonal emergencies.

The NYISO will declare an Alert State for real-time shortage of Operating Reserve, and activate all available in-state generating resources to re-establish the Operating Reserve. If required levels of real-time Operating Reserves cannot be re-established, the NYISO will utilize the EDRP to re-establish real-time Operating Reserves.

5.2 Procedures for Contacting Participants

Each CSP will designate a contact person responsible for interfacing between the NYISO and the CSP. When the EDRP is invoked, the NYISO will notify each CSP. Each CSP will notify the Demand Side Resources in accordance with the communications procedures agreed upon between the CSP and the Demand Side Resource.

The message from the NYISO will include an order to reduce load at a specific time. The message will also contain an estimate of the load reduction duration. The NYISO will keep the CSPs updated concerning the status of the load reduction.

If the estimated load reduction period ordered by the NYISO is extended, the NYISO will contact CSPs to provide an updated restoration time.

6.0 Metering, Verification, Billing and Settlement

6.1 Metering Requirements

6.1.1 Metering Device Requirements

CSPs are required to provide hourly interval metering data to validate performance. Demand Side Resources participating in EDRP must have a properly installed and calibrated integrated hourly metering device certified by a Professional Engineer as meeting ANSI C12 standards, or approved for use by the Meter Data Service Provider (MDSP) that provides integrated hourly kWh values for market settlement purposes. Demand Side Resources providing load reduction only should use the primary revenue meter as the source of performance data if it meets the integrated hourly kWh metering requirement.

6.1.2 Metering Configuration Requirements

Premises participating in the EDRP shall subscribe under one of two configurations: on-site generation only or load only. Integrated hourly metering devices shall be required as follows:

- 1) When a premise subscribes only the on-site generation, the hourly interval meter shall be installed to measure the generator's output; or
- 2) When a premise subscribes only the load, the hourly interval meter shall be installed to meter the entire facility or for totalized load, an hourly interval meter is required for each participating load.
- 3)

Figure 6.1 illustrates examples of acceptable configurations.

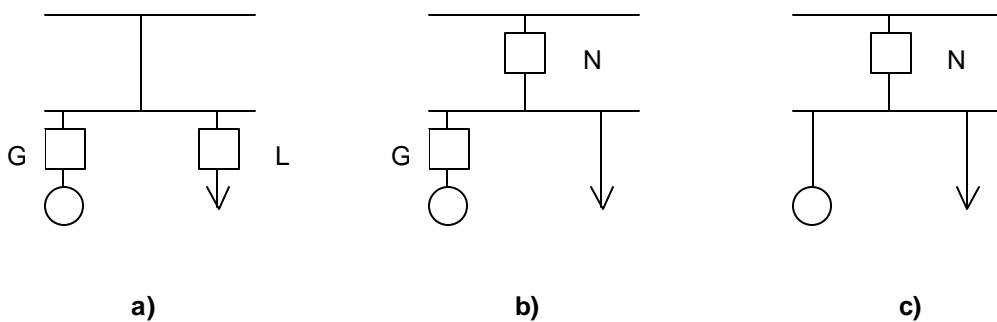

Figure 6.1 – Metering Configurations

6.2 Calculation of Customer Baseline

6.2.1 Historical Operating Data

CSPs shall be required to provide historical operating data for each load or on-site generator upon registration for participation in the EDRP. These requirements may be met by:

- 1) For on-site generation participating in the NYISO Special Case Resource (SCR) program and the EDRP

NYISO forms required to qualify as a Special Case Resource will satisfy the requirement for the EDRP program; or

- 2) For on-site generation that is only participating the EDRP

For on-site generation that is participating in the EDRP, but not participating in the NYISO Special Case Resource program the generator meter ID and MSP ID certifying meter installation must be supplied on the End-Use registration form in Attachment B;

- 3) For loads with existing interval meters

Provide a minimum of 1 complete billing period of hourly interval data immediately preceding the first Capability Period the load will participate in;

- 4) For totalized loads with existing interval meters

For totalized loads, provide hourly interval data for a minimum of 1 complete billing period of hourly interval data for all participating loads at the premise; or

- 5) For newly installed load interval meters

For newly installed interval meters, provide the prior three month's summary of monthly kwh consumption and demand values, if available.

6.2.2 Baseline Calculation Method

The Customer Baseline (CB) is the average hourly load, rounded to the nearest kWh, for each of the 24 hours in a day. The Customer Baseline type used for computing performance shall be the same day-type as the day-type of the EDRP event. Customer Baseline is required for EDRP metering configurations described in section 6.1.2 whenever load is participating in the EDRP program. For on-site generation, the generator output as metered will be used for performance as defined in section 6.3.

For the EDRP program, the CBL calculation will be for the four-hour window associated with the minimum payment period.

Customer Baseline – Weekday (CB-WD):

Performance in satisfaction of a bid for hours h(i) to h(j) in day d(n) would be assessed against a CBL determined by:

1. Calculating the energy consumption during similar hours over the past 10 weekdays, excluding days where curtailment due to participation in the EDRP or the Day-Ahead programs occurred.
$$kwh(k) = \text{sum}(h(i)...h(j)) \text{ for each day } k = d(n-1)...d(n-10)$$
2. Selecting the 5 highest values of kwh(k) and use those days d(l), l = 1...5 to calculate the CBL.
3. Calculating the CBL for each hour h(i) as the average of the five h(i) values for days d(l), l = 1...5.

- If more than 5 of the past 10 days have been excluded due to EDRP and/or Day-Ahead participation, look back beginning with day d(n-11) until 5 non-excluded days are found. In no cases will we go back further than day d(n-30).

As an example, Assume a 4-hour bid from 12 noon to 4 pm was accepted. The past 10 days Mwh consumption for similar hours was:

	Day n-1	Day n-2	Day n-3	Day n-4	Day n-5	Day n-6	Day n-7	Day n-8	Day n-9	Day n-10
12-1	10	8	9	7	10	12	5	7	7	8
1-2	11	6	12	8	11	8	8	8	6	10
2-3	7	9	9	6	9	9	8	8	6	9
3-4	5	6	7	6	7	7	6	7	5	6

Steps 1 and 2: sum the Mwh for the appropriate hours each day and select the 5 highest totals:

	Mwh n-1	Mwh n-2	Mwh n-3	Mwh n-4	Mwh n-5	Mwh n-6	Mwh n-7	Mwh n-8	Mwh n-9	Mwh n-10
	33	29	37	27	37	36	27	30	24	33
selected ?	Y		Y		Y	Y				Y

Step 3: Calculate the CBL for each hour using the five highest days selected:

	Day n-1	Day n-3	Day n-5	Day n-6	Day n-10	CBL
12-1	10	9	10	12	8	9.8
1-2	11	12	11	8	10	10.4
2-3	7	9	9	9	9	8.6
3-4	5	7	7	7	6	6.4

Weekend Days:

Saturday (CB-SA) and Sunday (CB-SU) CBLs will be computed separately.

- Calculate the energy consumption during similar hours over the past 3 Saturdays/Sundays, excluding days where curtailment due to participation in the EDRP or the Day-Ahead programs occurred.
- Select the 2 highest values of kwh and use those days to calculate the CBL.
- Calculate the CBL for each hour h(i) as the average of the values for the 2 highest days.
- Don't look back any more than 3 weekends to select the 2 highest periods (i.e, don't extend the window if exclusions occur).

Exclusion provisions:

Threetypes of exclusions are required when computing the calculation of the simple average: EDRP event days, days when load curtails as part of the Day-Ahead Load Reduction Program (DADRP), and shutdown days. :

- a) If one or more EDRP event days occur within the range of days used to calculate the Customer Baseline for the day of an EDRP event, the previous EDRP event day is eliminated from the average. The simple average for each hour is determined from the remaining days following the calculation provisions established above for the appropriate Customer Baseline day-type.
- b) If one or more DADRP event days occur within the range of days used to calculate the Customer Baseline for the day of a DADRP event, the previous DADRP event day is eliminated from the average. The simple average for each hour is determined from the remaining days following the calculation provisions established above for the appropriate Customer Baseline day-type.
- c) In the case where a day included in the simple average contains 4 or more consecutive hours with hourly values are less than 75% of the simple average for the corresponding hour, that day is excluded and the simple average is determined from the remaining days following the calculation provisions established above for the appropriate Customer Baseline day-type.

6.3 Performance Measurements and Compliance

6.3.1 Performance

Performance for metering configurations where load reduction is included is measured as the difference between the Customer Baseline and the actual metered usage by hour during the event. The Customer Baseline type used for computing performance shall be the same day-type as the day-type of the EDRP event. For on-site generation, the generator output as metered will be used for performance as defined below. The equations are given for the alternative metering configurations shown in Figure 6.1.

Load Only Configuration

For premises subscribing only the load, performance for each hour shall be calculated as:

$$P_h = (CB-xx)_h - AL_h \text{ (Meter configuration 6.1a)}$$
$$P_h = (CB-xx)_h - AN_h \text{ (Meter configuration 6.1b and 6.1c)}$$

Where P_h = performance for the hour

$CB-xx_h$ = Customer Baseline day-type (weekday – CB-WD, Saturday-CB-SA, or Sunday-CB-SU) for the hour as calculated using the simple average method described above in Section 6.2.2

AL_h = actual load for the hour using meter L in configuration 6.1a

AN_h = actual load for the hour using meter N in configuration 6.1b and 6.1c

On-site Generation Only Configuration

For premises subscribing only on-site generation, performance for each hour shall be calculated as:

$$P_h = OG_h$$

Where P_h = performance for the hour

OG_h = Metered On-site generator output for the hour using meter G in either configuration 6.1a or 6.1b

Load and On-site Generation Configuration

For premises subscribing both the on-site generation and the load and participating in the same EDRP event, performance for each hour shall be the net of on-site generation and load as defined below:

$$P_h = OG_h + [(CB-xx)_h - AL_h] \text{ (Meter configuration 6.1a)}$$

$$P_h = (CB-xx)_h - AN_h \text{ (Meter configuration 6.1b and 6.1c)}$$

Where P_h = performance for the hour

OG_h = Metered On-site generator output for the hour

$CB-xx_h$ = Customer Baseline day-type (weekday – CB-WD, Saturday-CB-SA, or Sunday-CB-SU) for the hour as calculated using the simple average method described above in Section 6.2.2

AL_h = actual load for the hour using meter L in configuration 6.1a

AN_h = actual load for the hour using meter N in configuration 6.1b and 6.1c

6.3.2 Compliance

Initial Compliance

Initial Compliance (IC) is measured as the first event hour in which performance in the hour is greater than zero (actual load is less than baseline).

Final Compliance (Restored Load)

Final Compliance (FC) is measured as the last hour in which performance is greater than zero, or the last hour of the EDRP event, whichever is earlier.

Compliance Period

The Compliance Period includes every hour in the EDRP event in which performance was greater than zero, beginning with the Initial Compliance hour and ending with the Final Compliance hour or the end of the EDRP event, whichever is earlier.

Table 6.1 illustrates examples of Initial Compliance and Final Compliance for an event starting at noon and lasting for five hours.

Table 6.1 - Examples of Performance during an EDRP Event

		NYISO EDRP Event								
		10 - 11 AM	11 - 12 AM	12 - 1 PM	1 - 2 PM	2 - 3 PM	3 - 4 PM	4 - 5 PM	5 - 6 PM	6 - 7 PM
Customer 1										
BL	125	125	125	125	150	150	150	150	150	125
AL	130	120	110	100	100	125	150	160	140	
Performance		5	15	25	50	25	0			
			IC	P	P	FC				
Compliance Period										
Customer 2										
BL	200	200	250	250	250	200	200	200	200	200
AL	200	200	250	225	200	175	175	175	200	
Performance			0	25	50	25	25	25		
				IC	P	P	FC			
Compliance Period										
Customer 3										
BL	300	300	350	350	350	300	300	300	300	300
AL	300	300	350	325	325	325	275	275	300	
Performance			0	25	25	0	25	25		
				IC	P	P	FC			
Compliance Period										
Legend	BL = BaseLine			IC = Initial Compliance					P = Performance	
	AL = Actual Load			FC = Final Compliance						

6.4 Settlement Procedures

CSPs shall provide verification of load reduced within 45 days of the emergency by providing interval billing meter data to the NYISO. Verification of load reduction not received by the NYISO within 45 days of the emergency may not be compensated pursuant to this program. All load reduction is subject to NYISO audit, and market monitoring unit review. The NYISO will be responsible for settlement payment.

6.4.1 Data Submission

A CSP will submit the response(s) of the Demand Side Resource(s) that participated in the emergency event to the NYISO within 45 days of the event being called. Failure to so provide such data will result in a CSP not receiving payment for its participation in the EDRP. In cases where the CSP is not the Meter Data Service Provider (MDSP), upon receipt of the data by the NYISO, the NYISO will immediately forward the data to the MDSP (in most, if not all, cases the Transmission Owner) for optional review. After 14 calendar days the NYISO will accept the data as submitted unless challenged by the MDSP. The ISO maintains the ability to subsequently review the data through the Market Monitoring Unit.

6.4.2 EDRP Reporting

The following forms shall be required for reporting performance in an EDRP event:

1. Event Participation Report – One for each load or on-site generation resource participating in a CSP's EDRP program;
2. Zone Detail Report – Records results of individual Event Participation Reports;
3. Zone Recap – Totals all Zone Detail Reports by Zone;
4. CSP Event Participation Summary Report – Reports load reductions and on-site generation by zone for payment.

6.4.3 Demand Side Resource Reduction Data

A CSP will submit response(s) of the Demand Side Resource(s) or on-site generation that participated in the emergency event aggregated by hour and by zone.

- a) Where the CSP's Demand Side Resource response is based on individual end-use loads alone or for premises with both participating load and on-site generation, the CSP is required to provide metered hourly interval data for each load and the on-site generation for the entire billing period in which the EDRP event occurred.
- b) Where the CSP's Demand Side Resource response is provided only from on-site generation, the CSP shall provide interval data for the 24-hour period ending midnight of the day of the EDRP event.
- c) If the EDRP event occurs less than 10 days into a billing period for any end-use load or premises with participating load and on-site generation, the prior month's bill period data must also be provided for that end-use load and on-site generation.

6.4.4 Data Format

Individual end-use or on-site generation hourly interval load data for the billing period in which an EDRP event occurred shall be submitted in electronic form to the NYISO in one of the following formats:

- a) MV-90 Row-Day format;
- b) Comma-Separated Variable format with the following minimum entries: meter ID, account number, date, hourly values from hour ending 01:00 through hour ending 24:00 for the entire billing period;
- c) other standardized formats as defined by NYISO.

Electronic data files may be submitted via one of the following methods:

- b) e-mail to: EDRPmgr@nyiso.com;
- c) CD-ROM or other electronic medium;
- d) other methods as defined by NYISO.

6.5 Energy Payments

6.5.1 Calculation of Payments

The NYISO will calculate the payment to CSPs using the following formula:

If the Emergency is four hours or longer:

$$P_h * \max(\$500, \text{LBMP}_{\text{RT Zonal, } h}) \text{ for each hour } h \text{ of the emergency}$$

If the Emergency is less than four hours:

$$P_h * \max(\$500, \text{LBMP}_{\text{RT Zonal, } h}) \text{ for each of the first two hours } h \text{ of the emergency, or for the duration of the emergency, whichever is greater (a minimum two-hour payment for performance)}$$

+

$$P_h * \text{LBMP}_{\text{RT Zonal, } h} \text{ for the remainder of the four-hour period.}$$

P_h = performance during hour h as defined in Section 6.3.1

$\text{LBMP}_{\text{RT Zonal, } h}$ = Real-time zonal LBMP for hour h

In most cases, NYISO Operators will specify a start and end time for the curtailment event. This information will be provided at least two hours prior to the starting time. Demand Side Resources will be expected to begin curtailment at the specified starting time. Participants who respond to a notice will be paid for performance in accordance with the above formulas for either the length of the curtailment period or four hours, whichever is greater. The four hour minimum payment period will begin at the time when the NYISO directs the retail end user to reduce load or, if load reduction is requested as soon as possible, when the retail end user begins his load reduction response.

CSPs that fail to provide load reduction when requested by the NYISO incur no penalties for failure to respond to the EDRP.

6.5.2 Distribution of Payments

Payments will be made by the NYISO directly to the CSPs.

Payments will be made by the ISO as part of the monthly bill generated by the ISO. The bill will record the payment as an emergency energy payment and will break down the payment by total kWh by zone, hourly zonal price, and total payment. These payments will be made to the CSPs for all emergencies which have had data submitted and approved in accordance with the data policy prior to the end of the month.

6.5.3 Verification, Errors and Fraud

All load reduction data is subject to audit by the NYISO and its market monitoring unit. Disputes concerning erroneous payments shall be resolved through the ISO's Dispute Resolution Procedures.

If the ISO in its review of the CSP's account determines the CSP or one of its customers has committed fraud to extract EDRP payments from the ISO, the ISO will have the right to ban the CSP or the CSP's customer from the EDRP as well as pursue all of the ISO's legal rights, at its sole discretion.

6.6 **Assessment of Program Charges**

6.6.1 Objectives of Cost Allocation

The costs for the program will equal the sum of all payments to customers calculated and paid out under Section 6.5.1.

In general, cost allocations should be designed with fairness and market efficiency (i.e., sending the correct price signals) in mind. If it can be determined that some locations provoke the need for a service and/or benefit from that service, then it is proper (from both a fairness and market efficiency perspective) to charge loads in those locations for the service specifically.

In the case of the EDRP, the cost allocation method should be done on a Zonal rather than statewide (i.e., "all loads - everytime") basis so that price signals will be produced that help encourage reliability improvements **where** reliability needs to be improved.

6.6.2 Causes for EDR Being Invoked

EDR will be invoked during situations in which one or both of the following actually occur or are predicted to occur *within a specific Zone or set of Zones*:

EDRP Condition 1

Internal Load **exceeds** Available (Internal) Generation *plus* Import Capability

Where Import Capability equals the lesser of Transmission Import Capability for that Zone (or set of Zones) **OR**
Supply Available for Import via that Transmission

EDRP Condition 2

Locational Operating Reserve Requirements **exceed** Available Operating Reserves.

6.6.3 EDR Cost Allocation

Based upon the objectives for cost allocation and the causes for initiating the EDRP (i.e., Conditions 1 and 2 as defined above), the following cost allocation method will be used:

Costs associated with EDRP will be allocated to all Loads in Zones for which EDRP will directly help to alleviate Conditions 1 and or 2.

The above rule translates into the following table:

Table 6.2 Emergency Demand Reduction Program Cost Allocation	
Location of Condition 1 and/or 2	EDR Cost Allocation
All or Part of One NYCA Zone (including relief for Local Reliability Rule problems within a Zone as requested by a TO)	All Loads in that Zone (L_z)
Two or More NYCA Zones	All Loads in those Zones (L_{zsum})
All Zones in NYCA	All Loads in NYCA (L_{system})
An External Control Area	The External Control Area ($L_{external}$)

6.6.4. Cost Allocation Formula

The monthly charge for EDRP payments will be recovered from all Transmission Customers, and will be calculated as the product of (A) payments made to Curtailment Service Providers and (B) the ratio of (i) the customer's billing units for the month to (ii) the sum of all billing units during that month..

Billing units shall be based on the Actual Energy Withdrawals for all Transmission Service to supply Load in the NYCA, and hourly Energy schedules for all Wheels Throughs and Exports. To the extent that the ISO activates the Emergency Demand Response Program in response to an Emergency or a real-time locational Operating Reserves shortage or a peak forecast of an Operating Reserves shortage in a particular zone or zones, including relief to meet a Local Reliability Rule within a zone as requested by a Transmission Owner, the billing units for such charges will be based on the Actual Energy Withdrawals in the affected zone(s) during the hours in which the Emergency Demand Response Program was activated.

LSEs shall also be required to pay the monthly charges calculated above for Transmission Customers which the LSE serves as retail access customers.

This charge will appear as a distinct line item on the customer bill and will have supporting material that will include the amount of load response for each hour of the emergency.

6.7 Timeline for Settlement

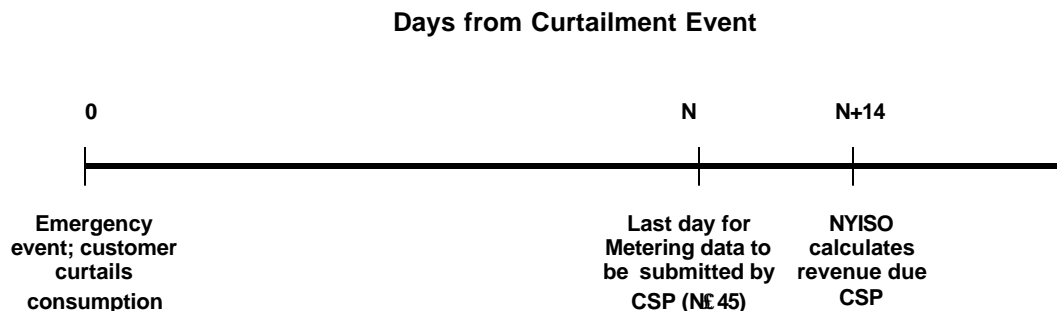

For the month immediately following the calculation of revenues to be paid to the CSP:

- Approximately on 8th of following month NYISO bills are generated; costs and revenues will be posted to the CSP and LSE Billing Statements

- Approximately on 16th payments are due from the LSEs
- Approximately on 22nd revenues will be due from the ISO to the CSPs

7.0 References

- [1] latest ICAP manual.
- [2] OATT (or Services Tariff) where NYISO members are defined.
- [3] Section 4.4.1 of the NYISO Emergency Operations Manual.
- [4] Section 3.2 of the Emergency Operations Manual.

Attachment A – Curtailment Service Provider (CSP) Registration

Emergency Demand Response Program (EDRP)

Entities applying for Curtailment Services Provider status under the Emergency Demand Response Program (EDRP) are advised that, as of April 17, 2001, the NYISO will begin accepting application paperwork for processing. The program will formally begin operation on the date of approval of the EDRP tariff by the Federal Energy Regulatory Commission (FERC). The NYISO fully expects that FERC will approve the EDRP tariff in a timely manner. In the unlikely event that FERC disapproves the EDRP tariff filing, the NYISO assumes no liability for damages, losses, claims, demands, suits, recoveries, costs and expenses, court costs, attorney fees, and other obligations by or to third parties, arising out of or resulting from the applicant's effort to subscribe Demand Side Resources.

The requirements for EDRP suppliers are controlled by the New York Independent System Operator's Services Tariff ("ISO Services Tariff") and the "NYISO Emergency Demand Response

This form must be faxed to **518-356-6208**, attention: **Manager EDRP** or e-mailed to **edrp@nyiso.com**

Operations Contact Information

All communications by the NYISO during an EDRP event will be sent to the primary and secondary contacts listed below (additional contacts should be provided on a separate sheet).

Primary Contact Name: _____
Organization: _____
Address: _____

Phone: _____
Cellphone: _____
Pager: _____
Fax: _____
E-mail: _____

Secondary Contact Name: _____
Organization: _____
Address: _____

Phone: _____
Cellphone: _____
Pager: _____
Fax: _____
E-mail: _____

Customer Aggregator or LSE, if applicable

Attachment C - Example Settlement Calculation

An emergency is issued on July 1, 2001 at 4pm
The customer responds by reducing their demand by 10MW
The emergency lasts for 4 hours
The emergency was activated to relieve a local system emergency in zone J

The market prices are:

Hour ending:
5 PM \$600
6 PM \$600
7PM \$600
8PM \$500

Using the formulas from above the revenues are:
 $(10 * 600) + (10*600) + (10*600) + (10*500) = \$23,000$

Data is submitted to the ISO on July 3rd by the CSP
The ISO sends to data to the TO on July 5th
The TO does not object to the data within 14 calendar days
On approximately August 8th the bill is sent to the CSP with a credit of \$23,000
The payment is transferred to the CSP on approximately August 26th.

On August 8th a bill is sent out to all LSEs with a charge of $\$23,000 * (LSE_{load}/Aggregate\ Zonal\ Load)$

On August 16th the LSEs pay \$23,000