

Day-Ahead Scheduling Manual

~~June 2001~~

August November 2012

NYISO DAY-AHEAD SCHEDULING MANUAL

Version: 4.01

Revision Date: ~~August~~November
1519, 2012

Committee Acceptance:

Review Date:

This document was prepared by:

New York Independent System Operator
3890 Carman Rd
Schenectady, NY 12303
(518) 356-6060
www.nyiso.com

Disclaimer

The information contained within this manual, along with the other NYISO manuals, is intended to be used for informational purposes and is subject to change. The NYISO is not responsible for the user's reliance on these publications or for any erroneous or misleading material.

©~~Copyright 1999-2006-2007~~12 New York Independent System Operator

Table of Contents

1. INTRODUCTION	1-1
1.1 References	1-1
2. OVERVIEW 2-1	
2.1 System Components	2-1
2.2 LBMP Time Line.....	2-5 2-4
2.3 Day-Ahead Functional Components.....	2-7 2-5
3. BID/POST SYSTEM.....	3-1
3.1 Bid/Post Functions.....	3-1
3.2 Bid/Post Process	3-1
3.3 Bid/Post Interfaces.....	3-5
3.3.1 SCUC	3-5
3.3.2 Interchange Scheduler.....	3-5
3.3.3 Real-Time Scheduling.....	3-5
3.3.4 Performance Tracking System.....	3-5
3.3.5 Billing & Accounting System.....	3-5
3.3.6 Historical Information Retention	3-6 3-5
3.3.7 OASIS	3-6 3-5
4. DAY-AHEAD SCHEDULING PROCESS.....	4-1
4.1 Day-Ahead Inputs & Outputs	4-1
4.2 SCUC Initialization	4-2
4.2.1 Day-Ahead Zonal Load Forecast	4-2
4.2.2 Assemble Day-Ahead Transmission Outages.....	4-2
4.2.3 Initial Generator Status and Commitment Rules.....	4-2
4.2.4 Scheduling a "Must Run" Generator.....	4-3
4.2.5 Multiple Response Rates for Generating Units	4-5 4-4
4.2.6 Day Ahead Reliability Unit (DARU) Commitment.....	4-6 4-5
4.2.7 Phase Angle Regulator Scheduling	4-7
4.3 Security Constrained Unit Commitment	4-8
4.3.1 SCUC Stages	4-8
4.3.2 SCUC Components.....	4-11
4.3.3 SCUC Inputs.....	4-13
4.3.4 Demand Curves	4-15
4.3.5 Constraint Breaking	4-15
4.3.6 SCUC Interfaces with Other Systems	4-16
4.4 Bilateral Transaction Evaluations.....	4-16
4.4.1 Firm Bilateral Transactions.....	4-16
4.4.2 Multi-Hour Block Transactions (MHBT).....	4-17 4-16
4.4.3 Non-Firm Bilateral Transactions.....	4-18 4-17
5. DAY-AHEAD INTERFACE TO THE DISPATCH DAY	5-1
5.1 Interchange Schedule Interface.....	5-1
5.1.1 User Interface.....	5-1
5.1.2 Functional Interfaces	5-2
5.2 Generation Schedule Interface.....	5-2

NYISO DAY-AHEAD SCHEDULING MANUAL

5.3 Ancillary Service Schedule Interface5-2

6. NYISO LOAD FORECAST PROCESS 6-1

6.1 Load Forecast Overview.....6-1

6.2 Load Forecast Functions.....6-1

6.2.1 Load Forecast Module6-1

6.2.2 Load Forecast Training Module 6-26-1

6.2.3 Load Forecast Functional Interfaces6-2

6.3 Load Forecast User Interface..... 6-36-2

6.4 MIS Load Modeling and LSE Responsibilities6-3

6.5 Load Forecasts for Facilities in the Market Information System6-4

7. SCUC EXECUTION 7-1

7.1 SCUC.....7-1

7.2 SCUC Execution Actions7-1

8. RELIABILITY FORECAST 8-1

8.1 Reliability Forecast Requirements.....8-1

8.2 Reliability Responsibilities8-2

8.3 Dealing with Insufficient Bids.....8-3

8.4 Reliability Assessment Processes8-4

9. INTERCHANGE COORDINATION PROCEDURE 9-1

10. SUPPLEMENTAL RESOURCE EVALUATION ONE OR MORE DAYS AHEAD 1

Attachment A: Calculation of Incremental Losses 7+

Attachment B: NYISO Load Forecasting Model..... 1

Table of Figures

FIGURE 2-1: NYISO BID-TO-BILL PROCESS ~~2-42-3~~

FIGURE 2-2: LBMP TIME LINE ~~2-62-4~~

FIGURE 2-3: DAY-AHEAD SCHEDULING DATA FLOW ~~2-72-5~~

FIGURE 4-1: MULTI-PASS SOLUTION PROCESS 4-10

FIGURE 4-3: TRANSACTION EXAMPLE ~~4-204-19~~

FIGURE 6-1: LOAD MODELING 6-4

FIGURE A-1: INCREMENTAL TRANSMISSION LOSSES 74

Table of Tables

TABLE 4-2: NON-FIRM TRANSACTION SELECTOR PROGRAM LOGIC ~~4-194-18~~

TABLE 4-4: TRANSACTION PARAMETERS ~~4-204-19~~

TABLE 8-1: RELIABILITY ASSESSMENT - LOAD AND CAPACITY TABLE 8-3

TABLE B-1: ALBANY AIRPORT ACTUAL AND FORECASTED WEATHER 3

TABLE B-2: ZONAL SHARE OF NEW YORK STATE'S 2010 POPULATION ~~43~~

TABLE B-3: WEATHER STATION WEIGHTS IMPUTED TO EACH ZONE 4

Revision History

Revision	Date	Changes
<u>4.1</u>	<u>11/13/2012</u>	<p><u>Section 4.2.7</u></p> <ul style="list-style-type: none"> ▪ <u>Changed The ABC interconnection will be scheduled ... plus “an adjustment of up to 13%”, into “0%” of PJM-NYISO Day-Ahead Market hourly interchange</u> ▪ <u>Changed The JK interconnection will be scheduled ... plus “an adjustment of up to 13%”, into “0%” of PJM-NYISO Day-Ahead Market hourly interchange</u> <p><u>Section 4.3.3</u></p> <ul style="list-style-type: none"> ▪ <u>Changed The incremental energy bid for a generator is modeled as “a piecewise linear monotonically increasing cost curve” into “a series of monotonically increasing constant cost steps”</u> <p><u>Deleted Section 6.4 MIS Load Modeling and LSE Responsibilities</u></p> <p><u>Deleted Section 6.5 Load Forecasts for Facilities in the Market Information System</u></p>
<u>4.0</u>	<u>08/15/2012</u>	<p><u>Added Section 1: INTRODUCTION</u></p> <p style="padding-left: 20px;"><u>1.1 Included References</u></p> <p><u>Re-numbered other sections</u></p> <p><u>Section 2</u></p> <ul style="list-style-type: none"> ▪ <u>Renamed section name from Day Ahead Scheduling to OVERVIEW</u> <p><u>Figure 2-1:</u></p> <ul style="list-style-type: none"> ▪ <u>Changed “Hour-Ahead Bids” into “Real-Time Bids”</u> <p><u>Section 2.2</u></p> <ul style="list-style-type: none"> ▪ <u>Added a paragraph about the daily reliability study over the seven-day period</u> <p><u>Broke “Functions” into Section 2.3.1: Primary Functions and Section 2.3.2: Supporting Functions</u></p> <p><u>Section 2.3.1</u></p> <ul style="list-style-type: none"> ▪ <u>Deleted “Eligible Customers”</u> <p><u>Section 2.3.2</u></p> <ul style="list-style-type: none"> ▪ <u>Deleted Post Unit Commitment (PUC)</u> <u>Replaced Performance Tracking System (PTS) with Automatic Generation Control (AGC)</u> <p><u>Section 2.3.3</u></p> <ul style="list-style-type: none"> ▪ <u>Added Automated Mitigation Process (AMP)</u> ▪ <u>Reserve and Regulation Requirements: Changed “on a Transmission Constraint Group basis” to “from the Energy Management System”</u> <p><u>Section 3.1 2nd paragraph</u></p> <ul style="list-style-type: none"> ▪ <u>Changed “general NYISO status to all Market Participants such as performing unscheduled commitment” to “generators that are committed for reliability under Operational Announcements on the ISO website”</u> <p><u>Section 3.2</u></p> <ul style="list-style-type: none"> ▪ <u>Changed Bilateral Transactions into External Transactions</u> ▪ <u>Added a bullet on Prohibited Transmission Paths for Validity Checks</u> <p><u>Section 3.3</u></p> <ul style="list-style-type: none"> ▪ <u>Deleted the section LBMP Calculation</u> ▪ <u>Deleted the section Loss Calculation</u>

		<p><u>Section 4</u></p> <ul style="list-style-type: none"> ▪ <u>Changed Bilateral Transactions into External Transactions</u> <p><u>Section 4.1</u></p> <ul style="list-style-type: none"> ▪ <u>Added Validated virtual generation and virtual load bids from the BID/Post System, and Lake Erie circulation assumptions in Inputs to Day-Ahead Scheduling</u> ▪ <u>Added in Outputs from Day-Ahead Scheduling:</u> <u>Non-Firm Available Transfer Capabilities (ATCs) posted on OASIS</u> <u>PAR Flows posted on OASIS</u> <u>Day-Ahead Limiting Constraints posted on OASIS</u> <u>Commitment schedule for External Transactions</u> <p><u>Section 4.2</u></p> <ul style="list-style-type: none"> ▪ <u>Changed Preliminary Zonal Load Forecast to Day-Ahead Zonal Load Forecast</u> ▪ <u>Moved Assemble Day-Ahead Transmission Outages to section 4.2.2</u> <p><u>Section 4.2.3</u></p> <ul style="list-style-type: none"> ▪ <u>Changed Performance Tracking into Automatic Generation Control</u> ▪ <u>Added: requirements across midnight are not recognized, except to the extent they are reflected in a late day start Bid</u> <p><u>Added Section 4.2.4: Scheduling a “Must Run” Generator</u></p> <ul style="list-style-type: none"> ▪ <u>Incorporated Technical Bulletin #26</u> ▪ <u>Added Submit a Bid in Self-Committed Fixed Mode</u> <p><u>Added Section 4.2.5: Multiple Response Rates for Generating Units</u></p> <ul style="list-style-type: none"> ▪ <u>Incorporated Technical Bulletin #71</u> ▪ <u>Changed “regulating response rate” into “regulating capacity response rate”</u> ▪ <u>Added “The regulation capacity response rate must not be slower than the slowest energy or emergency response rate.”</u> ▪ <u>Changed “Customer Relations” into “Stakeholder Services”</u> <p><u>Added Section 4.2.6: Day Ahead Reliability Unit (DARU) Commitment</u></p> <ul style="list-style-type: none"> ▪ <u>Incorporated Technical Bulletin #182</u> ▪ <u>Added “or for statewide reliability needs as initiated by NYISO,” are known as Day-Ahead Reliability Units (“DARU”)</u> ▪ <u>Changed the Generator’s contact may also reach out to inform the NYISO “at 518-356-6028” into “Grid Operations Department”</u> ▪ <u>Added: A DARU request by a Transmission Owner “or by the NYISO” may override a generator’s startup notification time</u> <p><u>Section 4.2.7</u></p> <ul style="list-style-type: none"> ▪ <u>Added “The desired flows will be established for the ABC, JK, and 5018 interconnections based on the following, pursuant to OATT Section 35, Attachment CC – JOA Among and Between NYISO and PJM, Schedule C and Schedule D” and added scheduling rules for ABC, JK and 5018</u> ▪ <u>Added the paragraph about scheduling of Northport PAR</u> <p><u>Section 4.3.1</u></p> <ul style="list-style-type: none"> ▪ <u>Incorporated changes in Technical Bulletin #49</u> ▪ <u>Pass #1: Changed the name to Bid Load, “Virtual Load and Virtual Supply” Commitment</u> ▪ <u>Changed “solves for supplying the Bid Load” into “commits and schedules generating units, including units nominated to be Day Ahead Reliability Units, to supply Bid Load (Physical and Virtual) less Virtual Supply”</u> ▪ <u>Added “Also, the program secures for certain Local Reliability Rules’ contingencies and monitored facilities”</u> ▪ <u>Pass #2: Changed “solves for supplying the forecast load” into “commits any additional units that may be needed to supply the forecast load”</u>
--	--	---

		<ul style="list-style-type: none"> ▪ <u>Added “Load bids (physical and virtual) and Virtual Supply bids are not considered in Pass #2”</u> ▪ <u>Added “In Pass #2, only the wind energy forecasts are used for scheduling intermittent resources that depend on wind as their fuel”</u> ▪ <u>Changed Pass #3 from “Local Reliability Rules Forecast Load Commitment” to “Reserved for future use”</u> ▪ Pass #4: <u>Changed “regulation” to “regulation capacity”</u> ▪ Pass #5: <u>Added “virtual load and virtual supply (where virtual supply is treated as negative virtual load)”</u> ▪ <u>Deleted “After this dispatch, the market power mitigation process is run to evaluate reserve price caps”</u> ▪ Forecast Required Energy for Dispatch (FRED) <u>Changed “Bilateral Schedules with Internal Sinks” into “import transaction schedules”</u> ▪ FRED Payment Rules <u>Added “subject to mitigation as appropriate”</u> <p>Section 4.3.2</p> <ul style="list-style-type: none"> ▪ Initial Unit Commitment (IUC): <u>Changed “performance tracking system” into “Automatic Generation Control system”</u> ▪ <u>Deleted New York Interface constraints</u> ▪ <u>Changed “An input processor takes the flat files from the Bid/Post system and load them into the IUC database” into “Bid data is transferred from the Bid/Post system into the RANGER database”</u> ▪ Unit Commitment (UC): <u>Changed “calculates the minimum bid price” into “calculates the minimum bid cost schedule”</u> ▪ <u>Added “Each UC solution is comprised of a physical dispatch and an ideal dispatch. The ideal dispatch allows for GTs to be dispatched across their entire operating range. The LBMPs are determined from this dispatch. The physical dispatch uses blocked bid limits for GTs modeling the physical manner in which GTs operate. The generation schedules are determined from this dispatch.</u> ▪ Infeasible Handling: <u>Changed “it automatically ceases to be enforced in a hard manner and is permitted to be violated” into “the constraint is relaxed, and solved for.”</u> <p>Section 4.3.3</p> <ul style="list-style-type: none"> ▪ Production Bid: <u>Changed “bid operating costs” into “incremental energy, minimum generation ... costs”</u> ▪ Operating Bid: <u>Changed “incremental operating bid” into “incremental energy bid”</u> ▪ <u>Added: The first segment is “determined by the minimum generation cost and” defined by the no-load cost axis intercept (\$/hr) and a slope (\$/MWh). The “11 incremental energy” segments ...</u> ▪ Startup Bid: <u>Changed the generator has been “down” to “off line”</u> ▪ Reserve Bid: <u>Changed regulation “cost” into “bid”</u> ▪ <u>Added: “It is given by a regulation available capacity (MW), a regulation capacity cost (\$/MW) and regulation movement cost (\$/MW)”</u> ▪ <u>Changed: For off-line and non-dispatchable generators, “the reserve bid is given by a reserve availability cost (\$/MW)”</u> ▪ <u>Added the paragraphs about Losses</u> ▪ Reserve Profile: <u>Changed “Regulation” into “Regulation capacity”</u> ▪ <u>Added: Regulation “available is limited by the regulation capacity response rate” and spinning reserve “is” determined by ...</u> <p>Added Section 4.3.4: Demand Curves</p> <p>Section 4.3.5</p> <ul style="list-style-type: none"> ▪ <u>Changed “1. Interruptible transactions” into “1. Regulation and reserve constraints”</u>
--	--	--

		<ul style="list-style-type: none"> ▪ <u>Changed “2. Export constraints” into “2. Transmission constraints”</u> ▪ <u>Changed “3. Import constraints” into “3. Interchange ramp constraints”</u> ▪ <u>Deleted “4. Reserve constraints”</u> ▪ <u>Changed “5. System generation requirement” into “4. System Demand”</u> ▪ <u>Changed “Soliciting additional bids” into “Dispatching generators to emergency upper operating limits”</u> ▪ <u>Deleted: “Requesting the” cancellation or rescheduling of outages</u> <p><u>Section 4.3.6</u></p> <ul style="list-style-type: none"> ▪ <u>Bid/Post System:</u> Deleted “and Penalty Factors”. ▪ <u>Added: “Later SCUC provides the Bid/Post System with accepted generator, transaction, and load bids, clearing prices, etc. This information is also passed on to the Real-Time Commitment process during the Dispatch Day.”</u> ▪ <u>Delete the bulletin on “Performance Tracking System”</u> ▪ <u>Changed “Outage Scheduler” into “Energy Management System (EMS)”</u> ▪ <u>Added “reserve and regulation requirements, unit status history and contingency definition”</u> ▪ <u>Changed “OS function” into “EMS”</u> ▪ <u>Changed “Post Unit Commitment” into “Load Forecaster”, and the paragraph into:</u> ▪ <u>“The SCUC function receives the load forecast for the Day-Ahead study period from the Load Forecasting program.”</u> <p><u>Added Section 4.4.2: Multi-Hour Block Transactions (MHBT)</u></p> <ul style="list-style-type: none"> ▪ <u>Incorporated Technical Bulletin #86</u> <p><u>Deleted Section 4.5: Post Unit Commitment (UCP)</u></p> <p><u>Deleted the original Section 5: Transmission Constraint Group (TCG) Assembly</u></p> <ul style="list-style-type: none"> ▪ <u>TCG is an obsolete process. The data that previously in the TCG file was the regulation and reserve requirements, which has been incorporated into other parts of the manual.</u> <p><u>Section 5.1.2</u></p> <ul style="list-style-type: none"> ▪ <u>Changed “Balancing Market Evaluation” into “Real-Time Market Evaluation”</u> ▪ <u>Added “along with available Real-Time transaction bids are passed”</u> ▪ <u>Added: “The final Desired Net Interchanges for the NYCA and neighboring Control Areas are passed from the IS+ function to the Real-Time Dispatch (RTD) function through the Bid/Post System.”</u> <p><u>Section 5.3</u></p> <ul style="list-style-type: none"> ▪ <u>Deleted “which then passes the information on to the BME process during the Dispatch Day”</u> ▪ <u>Added: “The Ancillary Services are evaluated again as part of the Real-Time Scheduling systems solutions and the accepted Ancillary Service schedules are passed to the Bid/Post System.”</u> <p><u>Section 6.1</u></p> <ul style="list-style-type: none"> ▪ <u>Added: each of the “eleven” NY Control Area Zones “and at the statewide level”</u> ▪ <u>Added: “The Load Forecast function uses a combination of advanced neural network and regression type forecast models to generate its forecasts.”</u> <p><u>Section 6.2</u></p> <ul style="list-style-type: none"> ▪ <u>Deleted the bulletin “Study Load Forecast Module”</u> <p><u>Section 6.2.1</u></p> <ul style="list-style-type: none"> ▪ <u>Added: “A single Load Forecast Module is used to produce the load forecasts for all the scheduling systems. The program automatically generates the 5 minute</u>
--	--	--

		<p><u>forecasts used by RTS. The hourly forecasts required for SCUC are published on demand for the current day and up to six days for each Zone. The published forecast is posted to the NYISO website by 08:00 a.m. every day, or as soon thereafter as is reasonably possible.”</u></p> <ul style="list-style-type: none"> ▪ <u>Added: “The forecasts that are produced for the scheduling systems represent only the expected demand usage and do not include transmission losses. The transmission losses are specifically computed as part of the scheduling systems’ functionality.”</u> <p><u>Deleted Section 6.2.2: Study Load Forecast Module</u></p> <p><u>Section 6.2.2</u></p> <ul style="list-style-type: none"> ▪ <u>Added: This module allows the generation of load forecasts models for each Zone “and for the New York Control Area”</u> <p><u>Section 6.2.3</u></p> <ul style="list-style-type: none"> ▪ <u>Changed “Bid/Post System” into “Oracle Information Storage and Retrieval (OISR) System”</u> ▪ <u>Added: with the “NYCA and Zonal hourly loads for storage”</u> ▪ <u>Added: “The MIS, SCUC and RTS systems can then retrieve the most up to date load forecast available.”</u> ▪ <u>Changed “Historical Data File” into “Historical Load Data”</u> ▪ <u>Deleted “and weather” data</u> ▪ <u>Changed “from the historical data file maintained from actual data retrieved from the on-line EMS” into “from the EMS through its PI Historical data”</u> ▪ <u>Changed “Weather Forecast File” into “Weather Data”</u> ▪ <u>Added: retrieves weather forecast “data and historical weather” data</u> ▪ <u>Changed “from the weather forecast data files maintained from data received from the weather service” into “from files received from the weather service”</u> <p><u>Section 6.3</u></p> <ul style="list-style-type: none"> ▪ <u>Changed: Initial forecasting is completed “by 6AM” to “prior to initializing SCUC”</u> ▪ <u>Deleted: “considered to be a working environment”</u> ▪ <u>Changed “The required files as input to the program as well as output of the program are in ASCII format which can be generated from other database tables for the input files, and be ported to other database tables for the output files” into “The required files as input to the program are in .csv format.”</u> ▪ <u>Changed “export a load forecast file in the format required for the multi-area Unit Commitment package to utilize” into “publish the load forecast data to OISR for the SCUC package to utilize”</u> ▪ <u>Deleted: “The exported areas can be specified to be either individual forecast areas or super zones.”</u> ▪ <u>Added: By 08:00 a.m., “or as soon thereafter as is reasonably possible”, the NYISO develops and posts its statewide Load forecast on the OASIS.</u> <p><u>Added Section 6.4: MIS Load Modeling and LSE Responsibilities</u></p> <p><u>Added Section 6.5: Load Forecasts for Facilities in the Market Information System</u></p> <p><u>Section 7</u></p> <ul style="list-style-type: none"> ▪ <u>Changed “Security Constrained Unit Commitment” into “SCUC”</u> <p><u>Section 7.1</u></p> <ul style="list-style-type: none"> ▪ <u>Changed “NYISO Operations Planning” into “Energy Market Operations”</u> ▪ <u>Changed “after the pre-UC process” into “after MIS DAM Market closing process has completed”</u> ▪ <u>Changed “S.P.I.D.E.R. workstation” into “RANGER system”</u> <p><u>Section 7.2</u></p>
--	--	--

		<ul style="list-style-type: none"> ▪ <u>Changed “1. ...Bid/Post” into “1. ... MIS”</u> ▪ <u>Changed “2. Acquire current Security Constrained Unit Commitment history” into “2. Transfer data from the EMS / Real Time server”</u> ▪ <u>Changed “3. Retrieve the TCG file” into “3. Perform the SRE end of the day fill in process”</u> ▪ <u>Deleted “7. Assemble output SCUC file”</u> ▪ <u>Changed “8. SCUC output file” into “8. SCUC output data”</u> ▪ <u>Deleted “9. Send SCUC information to the Historical Information System”</u> <p><u>Section 8.1</u></p> <ul style="list-style-type: none"> ▪ <u>NYISO Actions: 1). Deleted “(using LSE forecast data, where appropriate)”</u> <p><u>Section 8.3</u></p> <ul style="list-style-type: none"> ▪ <u>The Need for Bids: Changed “order on resources” into “commit resources in the DAM”</u> <p><u>Broke the end of Section 8.3 into a new section as 8.4 Reliability Assessment Processes</u></p> <ul style="list-style-type: none"> ▪ <u>Added: “The NYISO continually re-evaluates the reliability of the NYCA. There are several reliability assessments of any given Operating Day performed over various time horizons. The sequences of these evaluations are described next.”</u> ▪ <u>Real-Time Reliability</u> ▪ <u>Added: the NYISO shall commit all bid resources “subject to network security constraints.”</u> <p><u>Section 10</u></p> <ul style="list-style-type: none"> ▪ <u>Removed the original contents in this section, and referred to Transmission and Dispatch Manual section 5.7.5 through 5.7.12</u> <p><u>Attachment B</u></p> <ul style="list-style-type: none"> ▪ <u>Renamed the section to “NYISO Load Forecasting Model”</u> ▪ <u>Renamed “top/down – bottom/up” approach to “bottom/up”</u> ▪ <u>Changed: peak load and energy at “the NYCA and” zone level into “and obtains the NYCA level by summing over the zones”</u> ▪ <u>Added: “Once the peak load and daily energy are obtained, a series of hourly interval models are determined, comprised of four fifteen-minute interval models for each hour of the day.”</u> ▪ <u>Changed: The model’s structure flows from daily peak and energy at the “system (NYCA) level” into “zonal level”</u> ▪ <u>Deleted “to hourly loads at the system level, to daily energy at the zone level”</u> ▪ <u>Deleted: “The bottom/up component comes from using zone hourly loads and the zone’s share of load in an adjustment process that takes advantage of high quality information at the NYCA level to adjust the zone hourly loads. The next paragraphs clarify this approach.”</u> ▪ <u>Updated data in Table B-2: Zonal Share of New York State’s 2010 Population</u> <p><u>Deleted the paragraphs in the section “Using the Model”</u></p>
<u>3.0</u>	<u>05/06/2003</u>	<p><u>Section 1</u></p> <ul style="list-style-type: none"> ▪ <u>Replaced BME with RTC</u> ▪ <u>Replaced SCD with RTD</u> ▪ <u>Changed BSYS to Bid/Post System</u> ▪ <u>Changed UCP to PUC</u> <p><u>Section 2</u></p> <ul style="list-style-type: none"> ▪ <u>Replaced BME with RTC</u> ▪ <u>Replaced SCD with RTD</u> ▪ <u>Corrected inaccurate information</u>

		<ul style="list-style-type: none"> ▪ <u>Changed UCP to PUC</u> <p><u>Section 3</u></p> <ul style="list-style-type: none"> ▪ <u>Revised 3.3.1 with TB#49</u> ▪ <u>Revised 3.4.2 with TB#32</u> ▪ <u>Changed BSYS to Bid/Post System</u> ▪ <u>Changed UCP to PUC</u> <p><u>Section 4</u></p> <ul style="list-style-type: none"> ▪ <u>Replaced BME with RTC</u> <p><u>Section 6</u></p> <ul style="list-style-type: none"> ▪ <u>Created 6.4 with TB#13</u> ▪ <u>Created 6.5 with TB#6</u> ▪ <u>Changed BSYS to Bid/Post System</u> <p><u>Section 7</u></p> <ul style="list-style-type: none"> ▪ <u>Question</u> <p><u>Section 8</u></p> <ul style="list-style-type: none"> ▪ <u>Replaced BME with RTC</u> <p><u>Section 9</u></p> <ul style="list-style-type: none"> ▪ <u>Question</u> <p><u>Section 10</u></p> <ul style="list-style-type: none"> ▪ <u>Replaced BME with RTC</u> ▪ <u>Replaced SCD with RTD</u> <p><u>Attachment A</u></p> <ul style="list-style-type: none"> ▪ <u>Replaced BME with RTC</u> <p><u>Attachment B</u></p> <ul style="list-style-type: none"> ▪ <u>Removed NYPP</u> ▪ <u>Improved Exhibit titles and references</u>
<u>2.0</u>	06/12/2001	<p>Sect. 1.1.1, The Day-Ahead Subsystem Bullet 3</p> <ul style="list-style-type: none"> ▪ Delete: Step 1: Commits Generators (Set 1) based on Load Serving Entity bids, firm Bilateral Transactions, reserve requirements, and regulation requirements. The Load in this step is referred to as the First Settlement load. ▪ Step 2: Commits additional Generators (Set 2) as required in the event that the New York Independent System Operator load forecast is greater than the First Settlement load in Step 1. ▪ Step 3: Security Constrained Dispatch: based on the First Settlement load from Step 1 and the Generators from Sets 1 and Set 2. <p>Sect. 1.3, Functions</p> <ul style="list-style-type: none"> ▪ Delete: Network Sensitivity (NS) — The Network Sensitivity function provides the transmission loss Penalty Factors for use by the Security Constrained Unit Commitment program. <p>Sect. 1.3, Data Flow</p> <ul style="list-style-type: none"> ▪ Delete: b. Penalty Factors — The BSYS function retrieves penalty factors from the Network Sensitivity function. ▪ h. Outage Scheduler to SCUC — SCUC retrieves the TTCs for the transfer of energy between the Zones and Area to Area export limits. <p>Sect. 3.1, Inputs to Day-Ahead Scheduling</p> <ul style="list-style-type: none"> ▪ Delete last bullet: all-lines-in DFAX <p>Sect. 3.1, Outputs from Day-Ahead Scheduling</p> <ul style="list-style-type: none"> ▪ Delete first bullet: ▪ facility outages to the Real-Time Security Analysis (RTSA) model

	<p>Sect. 3.2.1</p> <ul style="list-style-type: none"> ▪ Delete first bullet: ▪ preparation of a path-oriented TTC flat file for SCUC input which is stored on the Transmission Constraint Group (TCG) file <p>Sect. 3.2.3</p> <ul style="list-style-type: none"> ▪ Add “and commitment rules” to the end of the subsection’s title <p>Sect. 3.2.3, 2nd paragraph</p> <ul style="list-style-type: none"> ▪ Replace “these” before “statuses” with “generating unit” <p>Sect. 3.2.3, 2nd paragraph</p> <ul style="list-style-type: none"> ▪ Delete 2nd sentence <p>Sect. 3.2.3 After 2nd paragraph, add:</p> <p>Initialization Status</p> <ul style="list-style-type: none"> ▪ When SCUC initializes, the statuses of the units that bid into the Day-Ahead Market (DAM) are based on their current operating mode at the time of initialization, with modifications. The modifications are the projected changes for the remainder of the day from the previous day’s DAM schedules. If a unit is not in the mode that SCUC expects it to be at the time of initialization, the current mode of the unit overrides the projected change. No units are considered must run in SCUC. ▪ BME honors all day-ahead commitments of internal generation resulting from SCUC, except for quick-start gas turbines. The unit statuses at the time of initialization are based on the current operating mode at the time of initialization, modified to include projected changes from the previous hour’s evaluation. <p>Startup Time</p> <ul style="list-style-type: none"> ▪ Either a startup versus downtime curve or a notification time can be provided for SCUC. If both are provided, the startup versus downtime curve overrides the notification value. ▪ SCUC posts the results for the next day’s DAM at 11:00 a.m. If a unit is down at posting time, the startup time is measured from the time of posting. The unit is recognized as unavailable until the startup notification period has elapsed. ▪ If a unit is running but projected to come down after posting time, a bid for the unit in SCUC indicates that it is willing to operate. Neither a startup versus downtime curve nor a notification time value is recognized. ▪ BME ignores both startup versus downtime curves and notification times. A bid in the Hour-Ahead-Market indicates that a unit is able to operate in that hour if scheduled. <p>Minimum Run Time</p> <ul style="list-style-type: none"> ▪ In SCUC, the minimum run time is honored within the 24-hour evaluation period only; requirements across midnight are not recognized. A unit must bid appropriately to enable commitment in the next day. ▪ BME ignores minimum run time. <p>Minimum Down Time</p> <ul style="list-style-type: none"> ▪ SCUC honors the minimum down time within the 24-hour evaluation period only; requirements across midnight are not recognized. A unit must bid appropriately to preclude commitment in the next day. ▪ The minimum down time is honored at all times by BME. <p>Sect. 3.2.4, #2</p> <ul style="list-style-type: none"> ▪ Replace “contingencies occur” with “maintenance facility outages are scheduled” <p>Sect. 3.2.4</p> <ul style="list-style-type: none"> ▪ Delete # “4) Interface schedule and actual flows will be posted.”
--	---

		<p>Sect. 3.3.1</p> <ul style="list-style-type: none"> ▪ Insert new # “4) Committing sufficient Capacity to meet the ISO's Load forecast and Local Reliability Rule requirements.” And renumber remaining item in list. <p>Sect. 3.3.1</p> <ul style="list-style-type: none"> ▪ Paragraph after #5, Revise to read as follows: “To meet the above requirements, the SCUC algorithm is a five pass process in which three security constrained commitment passes and two security constrained dispatch passes are executed in sequence as follows:” <p>Delete:</p> <ul style="list-style-type: none"> ▪ Step 1: SCUC with Bid Load - A First SCUC will be based on day-ahead firm bilateral transaction schedule requests, supplier bids, and LSE load bids. This will result in Generator Set #1, and LBMPs that will be used in the Second SCUC. ▪ Step 2: SCUC with Forecast Load - A Second SCUC will result in an additional Generator Set #2. This SCUC run will use: <ul style="list-style-type: none"> ▪ a. The NYISO forecasted load. ▪ b. Committed generators from the First SCUC (Gen Set #1) with their start-up and minimum generation price bids set to zero for the hours they were committed, and minimum generation limit set to the First SCUC dispatch level. Additionally, their incremental energy price bids will be set equal to zero. ▪ c. Other bid generators that were not committed in the First SCUC. For the Second SCUC, the bids for the previously non-committed generators will be adjusted in the two following ways to select Gen Set #2: <ul style="list-style-type: none"> ▪ 1. Each will have its Min Gen Price Bid <i>reduced</i> by its Min Gen Bid multiplied by LBMP from the First SCUC. <i>For example, if a non-committed generator had a \$4,000/hr Min Gen Price Bid with a Min Gen Bid of 100 MW, and LBMP from the First SCUC for a specific hour was \$30/MWh, then that generator's Min Gen Price Bid for that hour will be set equal to $(\\$4,000 - (100 \times \\$30)) = \\$1,000/hr$.</i> ▪ 2. Each will have its incremental energy price bid set equal to zero (this is intended to minimize the cost of providing additional operating reserves for the non-bid portion of the ISO's total load forecast, but not necessarily minimizing the cost of energy to serve that non-bid load). ▪ Step 3: SCUCD Ideal Dispatch to Set Preliminary Day-Ahead Schedule - Following completion of the two sets of SCUC, a first Day-Ahead hourly Security Constrained Unit Commitment Dispatch (SCUCD) will be performed to produce First Settlement LBMPs. This first "ideal" SCUCD will use: <ul style="list-style-type: none"> ▪ a. The Load Bids from the First SCUC. ▪ b. In the interim: the committed generators from Gen Set #1 (including Gen Set #1 committed Quickstart generators) using their actual bid data and prices, with the exception that Gen Set #1 Quickstart generators will have minimum operating levels of 0 MW and maximum operating capabilities equal to their maximum bid MW. ▪ Ultimately: the combination with or without any or all Quickstart generators from Gen Set #1 which yields the least expensive dispatch will be passed to Step #4 below. ▪ c. The committed generators from Gen Set #2 (excluding Gen Set #2 committed Quickstart generators) using their actual bid data and prices. ▪ If Quickstart generators in the first "ideal" SCUCD are dispatched to their maximums, they will set LBMP. Thus, a Gen Set #1 Quickstart generator will set LBMP only when it is needed to economically serve load. ▪ Step 4: SCUCD Real Dispatch to Set Day-Ahead Schedules and LBMPs <ul style="list-style-type: none"> ▪ In the Interim: SCUCD will be run a second time with the same parameters as the first SCUCD except that all Gen Set #1 generators and all Gen Set #2 generators (excluding Gen Set #2 Quickstart generators) will be run at least at minimum ▪ Ultimately: All generators in Step #3 that were dispatched above zero will be run at least at minimum. ▪ This second "real" SCUCD will be performed to produce generator schedules and
--	--	---

		<p>load schedules to be used for First Settlement forward contracts.</p> <ul style="list-style-type: none"> ▪ <u>Note:</u> Commitment means to start-up a generator to run at or above its minimum generation level. Therefore, if a Quickstart generator is shown to be needed in the first SCUCD, it is scheduled on-line to run at maximum by the second SCUCD because the minimum level for a Quickstart generator is typically the same as its maximum level. Quickstart generators have start-up times of one hour or less. <p>Sect. 3.3.1</p> <ul style="list-style-type: none"> ▪ Insert material from Tech Bulletin #49 <p>Sect. 3.3.2</p> <ul style="list-style-type: none"> ▪ Under “Initial Unit Commitment (IUC):” delete last bullet: “penalty factors” <p>Sect. 3.3.3, Under “Startup and Shutdown Constraints”</p> <ul style="list-style-type: none"> ▪ Delete 2nd paragraph: Conflicts between these limits and generator maintenance schedules are resolved using the constraint breaking rules established by the NYISO. <p>Sect. 3.3.3, Under “Penalty Factors”</p> <ul style="list-style-type: none"> ▪ Delete 1st paragraph: “Transmission loss Penalty Factors are input for each generator. The Penalty Factors multiply the generation operating bid cost during the schedule and dispatch optimization. A single set of Penalty Factors is used for each SCUC execution.” And replace with “The SCUC application uses the ABB Security Analysis (SA) module to generate delivery factors for each time step in the commitment period. The delivery factors for each time step reflects the network topology expected for that time period and the generation dispatch from the Unit Commitment (UC) module.” <p>Sect. 3.3.5</p> <ul style="list-style-type: none"> ▪ Delete section: “NYISO Operator User Interface – Operator Participation, Operator participation is a feature of the Unit Commitment that enables the operator to override the UC solution with direct instructions as to how specific generators are to be loaded and/or dispatched. The costing and dispatching algorithms of UC are then rerun to implement these instructions. ▪ Operator participation is a “total” override capability. That is, the operator must tell whether a generator is to be ON during a specified amount of time, and if so whether it is to be ON at a specified MW level or at a level dictated by economics (economically dispatched). Also, if a generator is specified to be ON, whether it contributes toward reserve as usual or whether it does not contribute to reserve at all. ▪ It is necessary to emphasize here that the original commitment sequence of generators remains unchanged unless modified by the operator. When running under the operator participation mode, the commitment optimization algorithms are not re-executed. A consequence of this is that constraints such as minimum uptime and downtime may be violated based on operator directives. ▪ Minimum up and downtime, ramp rate, start-up and shutdown constraints are checked and violations are reported. <p>Sect. 3.4.2</p> <ul style="list-style-type: none"> ▪ Delete material after 1st paragraph and replace with new material. <p>5.3, Replace current #3</p> <p>Determine the zonal load forecast.</p> <ul style="list-style-type: none"> ▪ The state-wide load forecast used in SCUC is based on a summation of the zonal load values. The ISO Services tariff requires that the LSE load forecasts be considered in the development of the state-wide forecast when it is consistent with the ISO forecast. The LSE zonal load forecast is considered to be consistent with the ISO forecast when the sum of the LSE zonal load forecasts on a control area basis is less than 105% of the ISO forecast on a state-wide basis and when the LSE forecast is within 100% to 105% of the ISO forecast on a zonal basis. Therefore, if the sum of the LSE zonal load forecasts is not consistent with the ISO state-wide forecast, then the LSE zonal load forecasts are not considered. Additionally, if a
--	--	--

		<p>LSE zonal load forecast is not consistent with the ISO zonal forecast, then the LSE zonal load forecast is not considered. Therefore, the zonal load values used in SCUC are determined using the following rules:</p> <p>The Bid Load plus Bilateral contracts zonal value is used as the zonal load value when:</p> <ul style="list-style-type: none"> ▪ a) the Bid Load plus bilateral contracts zonal value is greater than the ISO zonal load forecast and, ▪ b) the Bid Load plus bilateral contracts zonal value is greater than the LSE zonal load forecast, when determined to be consistent with the ISO forecast. <p><u>The ISO zonal load forecast</u> is used as the zonal load value when:</p> <ul style="list-style-type: none"> ▪ a) the ISO zonal load forecast is greater than the Bid Load plus Bilateral contracts zonal load value and, ▪ b) the ISO zonal load forecast is greater than the LSE zonal load forecast, when determined to be consistent with the ISO forecast. <p><u>The LSE zonal load forecast</u>, when determined to be consistent with the ISO forecast, is used as the zonal load value when:</p> <ul style="list-style-type: none"> ▪ a) the LSE zonal load forecast is greater than the ISO zonal load forecast and, ▪ b) the LSE zonal load forecast is greater than the Bid Load plus bilateral contracts zonal value.
<u>1.0</u>	09/03/1999	<p>Exhibit 3.1</p> <ul style="list-style-type: none"> ▪ New Exhibit <p>Attachment A</p> <ul style="list-style-type: none"> ▪ Addition of last 2 paragraphs of Attachment A. <p>Sect. 3.2.4 Page 4</p> <ul style="list-style-type: none"> ▪ Phase Angle Regulator (PAR) Scheduling <p>Sect. 3.3.1 Page 6, 7</p> <ul style="list-style-type: none"> ▪ SCUC Stages

<p><u>Initial Release</u></p>	<p>06/05/1998</p>	<p>Information on the following topics was added</p> <ul style="list-style-type: none"> ▪ 1. Negative Congestion and Non-Firm Transmission Service <ul style="list-style-type: none"> ▪ a. Non-Firm transmission service that encounters negative congestion will not be curtailed. ▪ b. Non-Firm transmission service that encounters negative congestion will not be paid for the negative congestion. ▪ 2. Supplemental Resource Evaluation (SRE) Process ▪ 3. Security Constrained Unit Commitment (SCUC) Algorithm to be implemented ▪ 4. Phase Angle Regulator (PAR) Scheduling in Security Constrained Unit Commitment (SCUC) ▪ 5. Minimum run times Extending Past the Commitment Period <ul style="list-style-type: none"> ▪ a. The Tariff specifically precludes committed generators from remaining on-line past the end of the Dispatch Day to fulfill minimum run time requirements. ▪ b. A generator which needs to remain on-line past the end of the Dispatch Day or Dispatch Hour to fulfill its minimum run time will have the responsibility to structure its bid in such a way as to continue to be economic as evaluated by SCUC or BME so it is scheduled to remain on-line. ▪ 6. Dealing with the Potential for Insufficient Bids <ul style="list-style-type: none"> ▪ The NYISO will perform a reliability assessment to determine if projected Operating Reserves over an upcoming period will be adequate and will take certain steps if deficiencies are anticipated. ▪ 7. FRED: Forecast Required Energy for Dispatch <ul style="list-style-type: none"> ▪ FRED is additional expected energy needed to meet the NYISO forecasted load that is in excess of the sum total of Day-Ahead load bids and scheduled bilateral loads. For each hour, FRED should at least equal the NYISO NYCA Load Forecast minus the sum of Day-Ahead Internal Load Bids and Bilateral Schedules with Internal Sinks ▪ 8. Data Requirements for Bilateral Transaction Requests
-------------------------------	-------------------	---

1. INTRODUCTION

This *NYISO Day-Ahead Scheduling Manual* is one of a series of manuals within the Operations Manuals. This Manual focuses on describing each of the Day-Ahead scheduling processes that are facilitated and/or controlled by the NYISO.

The *NYISO Day-Ahead Scheduling Manual* consists of eleven sections and two attachments as follows:

- Section 1: Introduction
- Section 2: Overview
- Section 3: Bid/Post System
- Section 4: Day-Ahead Scheduling Process
- Section 5: Day-Ahead Interface to the Dispatch Day
- Section 6: NYISO Load Forecast Process
- Section 7: SCUC Execution
- Section 8: Reliability Forecast
- Section 9: Interchange Coordination Procedure
- Section 10: Supplemental Resource Evaluation
- Attachment A: Calculation of Incremental Losses
- Attachment B: NYISO Load Forecasting Model

1.1 References

The references to other documents that provide background or additional detail directly related to the *NYISO Day-Ahead Scheduling Manual* are:

- NYISO Emergency Operations Manual
- NYISO Accounting & Billing Manual
- NYISO Transmission & Dispatching Operations Manual
- NYISO Market Participant User's Guide
- New York ISO Tariffs
- NYSRC Agreement
- NYSRC - Reliability Rules Manual

1.2. OVERVIEW

This section describes the overall Locational Based Marginal Pricing (LBMP) process, which sets the stage for the Day-Ahead activities.

1.12.1 System Components

The overall Bid-to-Bill Process from the time Bids are received to the time that payments are made consists of the following major components:

- Bid/Post System
- Day-Ahead Subsystem
- Real-Time Scheduling (RTS) Subsystem
 - Real-Time Commitment (RTC)
 - Real-Time Dispatch (RTD)
- Settlement Subsystem

Additionally, the Historical Information Retention system and the Supervisory Control and Data Acquisition (SCADA) subsystem provide services to these major components.

Bid/Post System

The purpose of the Bid/Post System is to:

- Accept generator and load bids and schedules for Bilateral-External Transactions
- Post the public results of the Day-Ahead Market, Balancing Market Evaluation, Real-Time Commitment (RTC), and Real-Time Dispatch (RTD).

Day-Ahead Scheduling Subsystem

The Day-Ahead scheduling process consists of the following principal functions:

- Assemble Day-Ahead Transmission Outages; Updates Total Transfer Capabilities, constraints and the Security Constrained Dispatch-Unit Commitment (SCUC) model; post updated Total Transmission Capability on the Open Access Same Time Information System.
- Produce NYISO Preliminary-Day-Ahead Zonal Load Forecast; ~~Based based~~ on weather forecasts and the load forecast model.
- Perform Security-Constrained-Unit-Commitment (SCUC). ~~Performs commitment and scheduling in three steps.~~
- Tabulate and Evaluate Non-Firm Transactions; In the event that there is no congestion, the non-firm transactions are scheduled in sequence up to the Available Transfer Capabilities of the NYS Transmission System.
- Perform Automated Mitigation of generator offers.

~~The Hour-Ahead~~ Real-Time Scheduling Subsystem

Approximately ~~every 15 minutes~~ 90 minutes ahead of each hour, ~~an a~~ Real-Time Commitment (RTC) evaluation takes place to ensure that the ~~Day-Ahead-First Settlement~~ schedules meet all of the reliability requirements. Each Real-Time transaction is evaluated independently against the Day-Ahead transactions and Generator Bids, using the RTC

program. Any new firm External Transactions will be scheduled by RTC, which could displace some of the Day-Ahead non-firm transactions. If necessary, 10 and 30-minute resources will also be scheduled. The results are then posted every 15 minutes.

Approximately every 5 minutes, the RTD-Real-Time Dispatch (RTD) uses Bid curves of the New York Control Area (NYCA) generators to dispatch the system to meet the load while observing transmission constraints. Bid curves will consist of a combination of incremental bid curves provided by generators bidding into the LBMP market and decremental bid curves provided by generators serving Bilateral Transactions.

Settlement Subsystem

During each hour of operation, the results of SCUC, RTSCD and Automatic Generation Control (AGC) are captured and stored for later use by the Billing subsystem. The NYISO will have all the information necessary to determine all of the charges and payments, which must flow between the NYISO and the Market Participants.

NYISO DAY-AHEAD SCHEDULING MANUAL

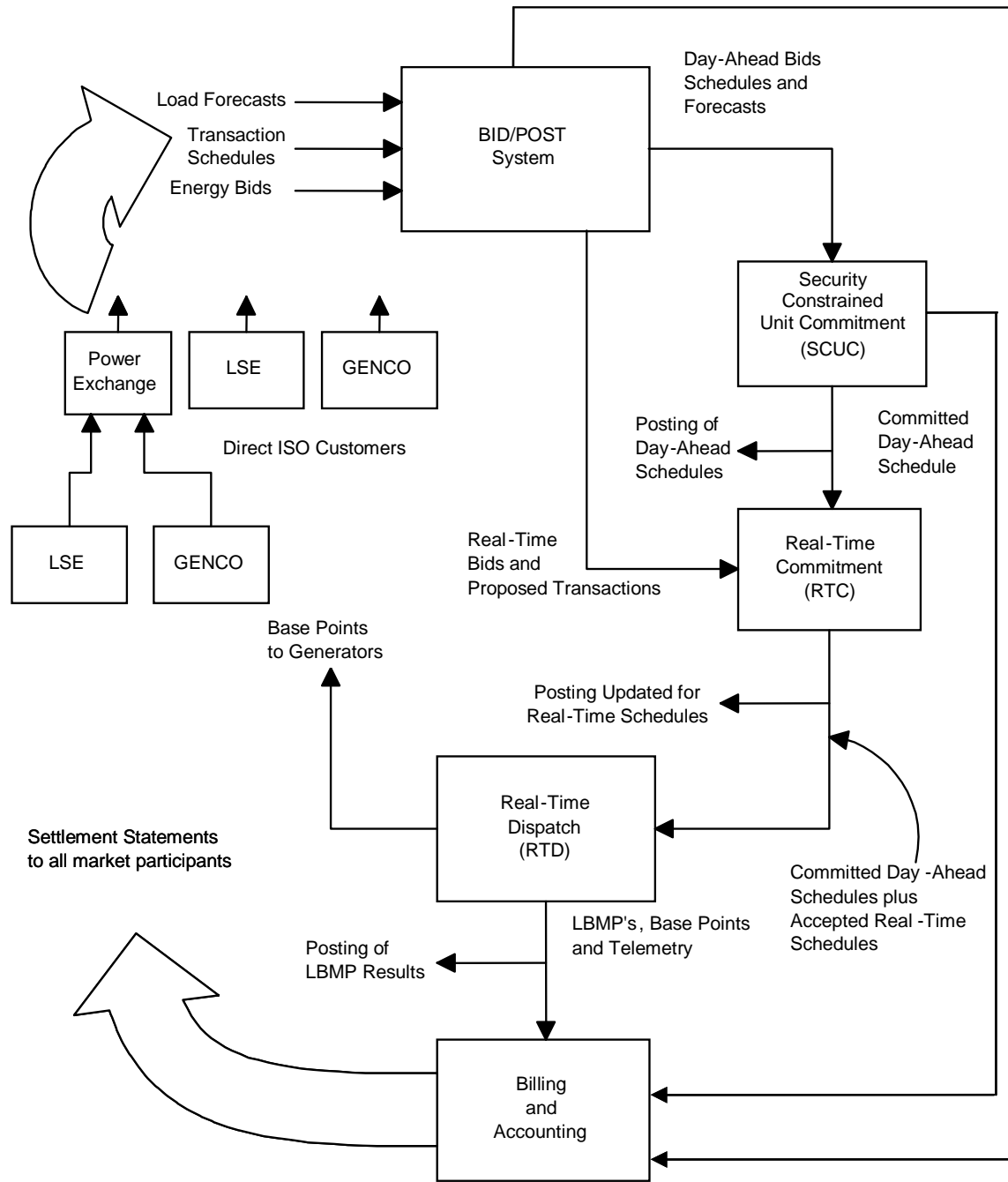

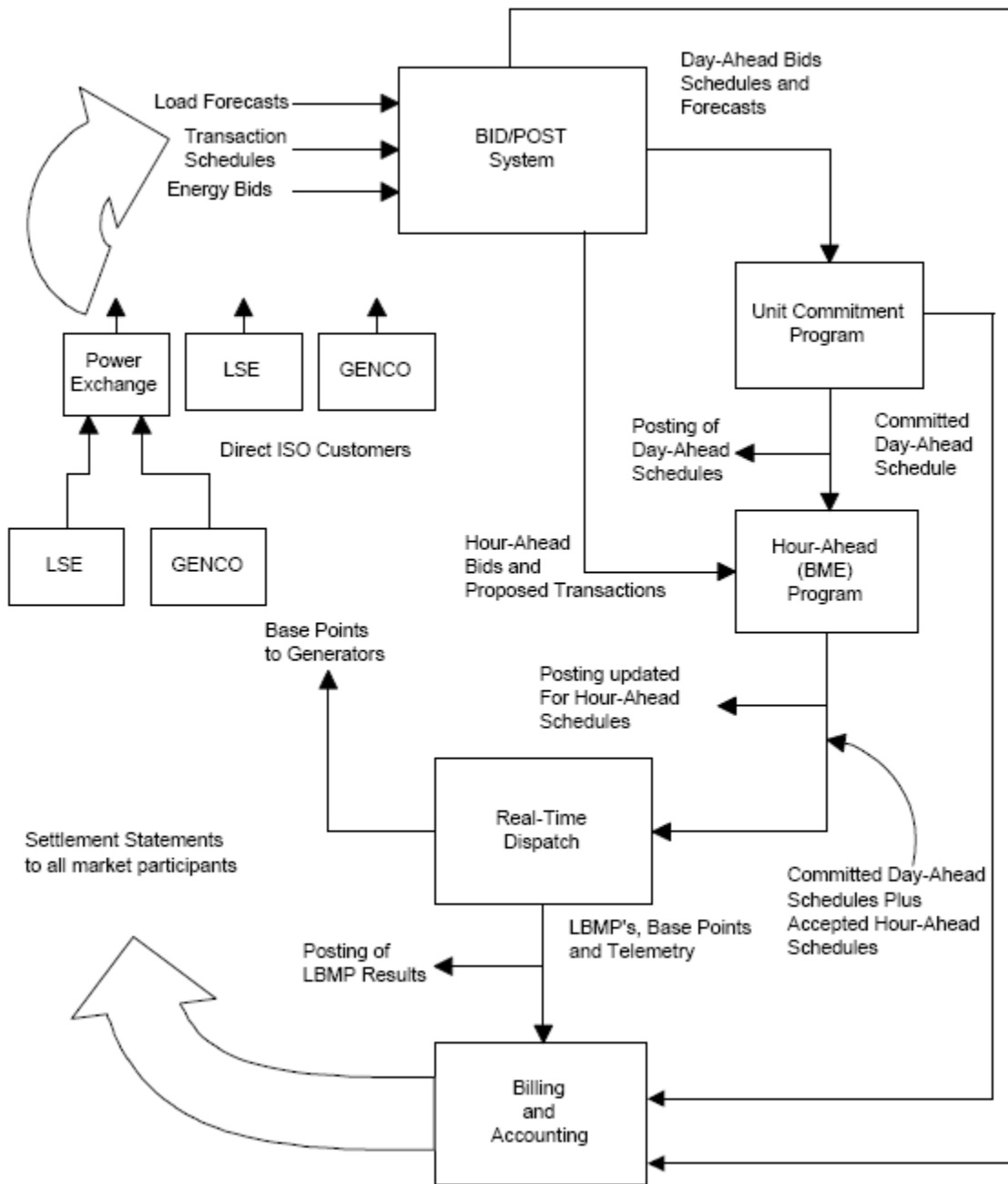
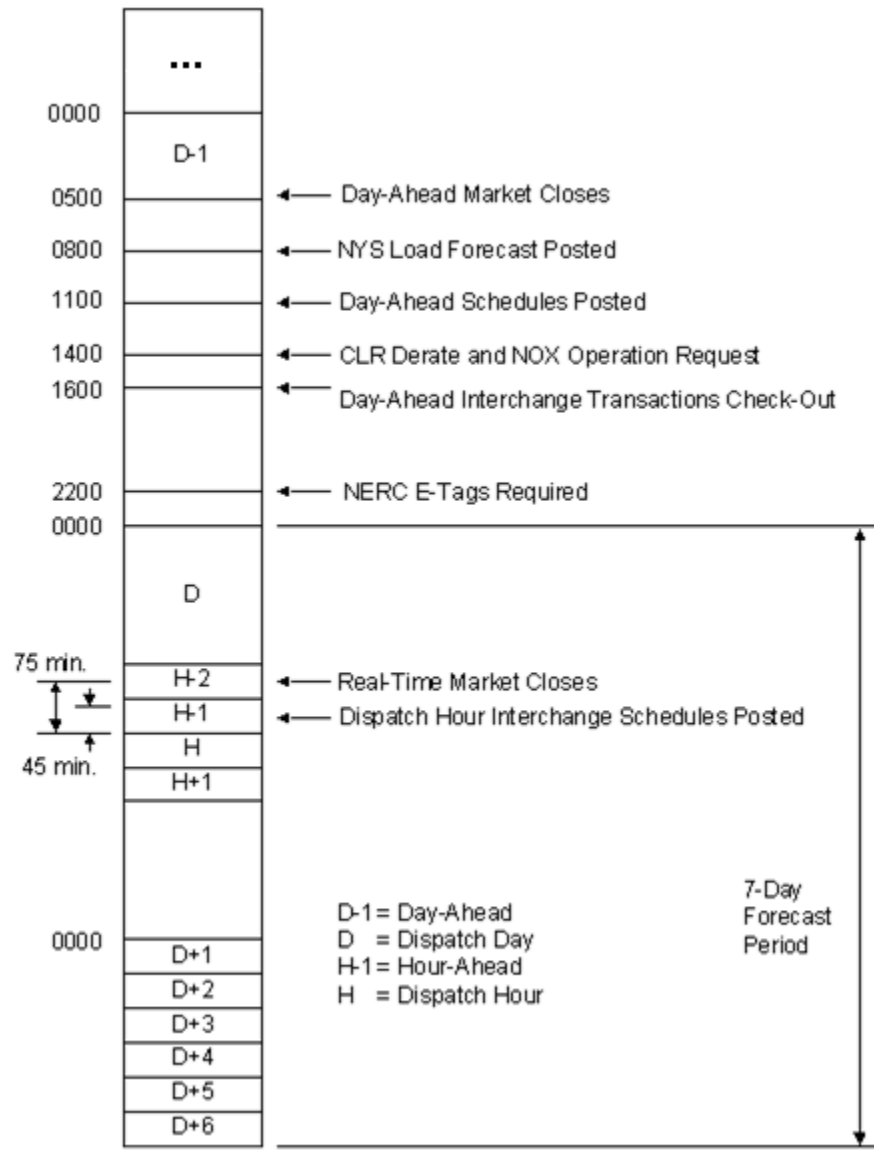

Figure 2-1: NYISO Bid-to-Bill Process

1.22.2 LBMP Time Line

The sequence of events for the implementation of LBMP is shown in Figure 2-2.



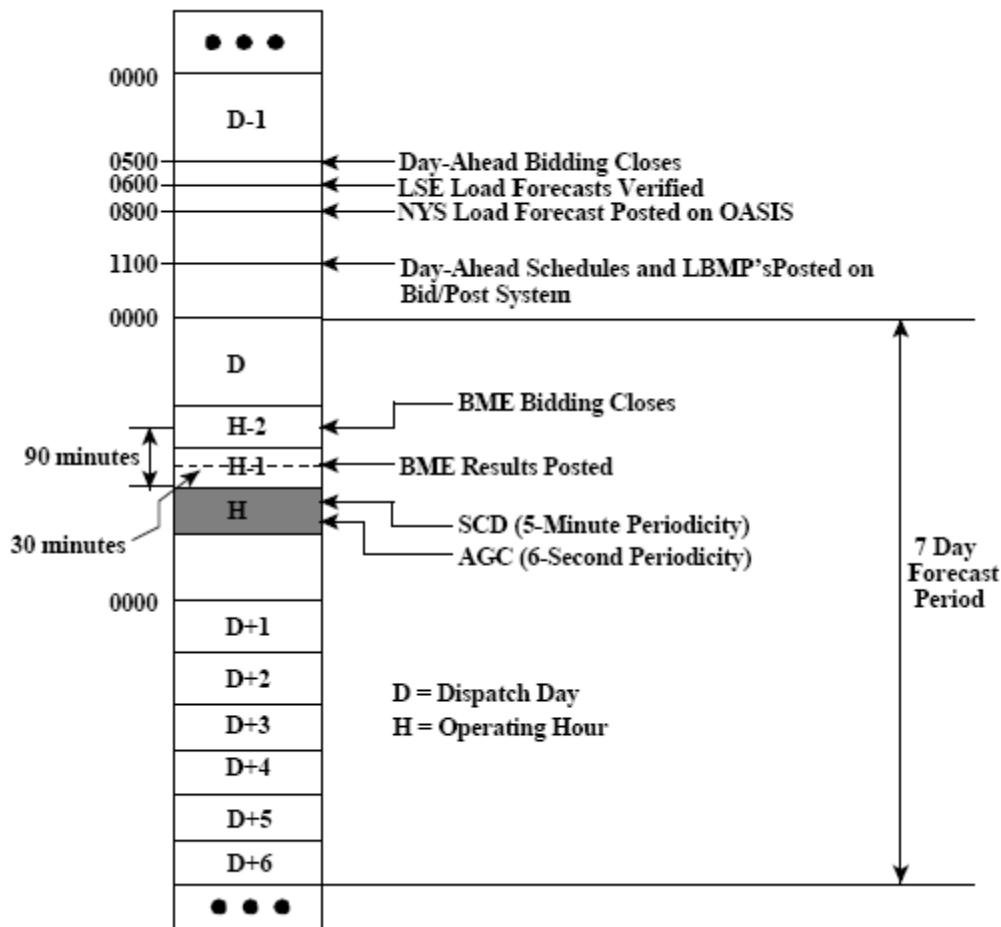

Figure 2-2: LBMP Time Line

Finalized Day-Ahead bids data is due in at must be submitted by 05:00 a.m. AM a.m. (0500 hours) (or by 4:50 a.m. for some External Transaction bids pursuant to MST Section 4.2.1.1) on the each day prior to the Dispatch Day for the full commitment period.

By 11:00 on the day prior to the Dispatch Day, the ISO shall complete the Day Ahead scheduling process and post on the Bid/Post System the Day Ahead schedule Each Day-Ahead a Reliability Study is run for up to a seven day seven day period. This study evaluates resources with longer start up times. Units that are committed are guaranteed a minimum generation bid cost recovery.

Commitment is completed by 11:00 a.m. AM (1100 hours) each day By 11:00 a.m. on the day prior to the Dispatch Day, the ISO shall complete the Day-Ahead scheduling process and post on the Bid/Post System the Day-Ahead schedule as per section 4.2.5 of the Market Services Tariff. LBMPs are posted on the Bid/Post System as public data and commitment schedules are posted on the Bid/Post System as private data.

Day-Ahead bids are locked for the Day-Ahead period while under evaluation and when accepted. Bids may be left standing or withdrawn if not accepted. Standing bids may be used in Supplemental Resource Evaluation (SRE).

In accordance with section 4.2.4 of the Market Services Tariff, each day a reliability study is run over the seven (7)-day period that begins with the next Dispatch Day. This study evaluates if resources with longer start-up times are required to meet forecasted Load and reserve requirements. Units that are committed are guaranteed a minimum generation bid cost recovery pursuant to the provisions of Attachment C of the Market Services Tariff.

1.32.3 Day-Ahead Functional Components

The following figure shows the interaction and data flow between the various functional components that involve the Day-Ahead process. Each of the blocks and major data flows is described after the figure.

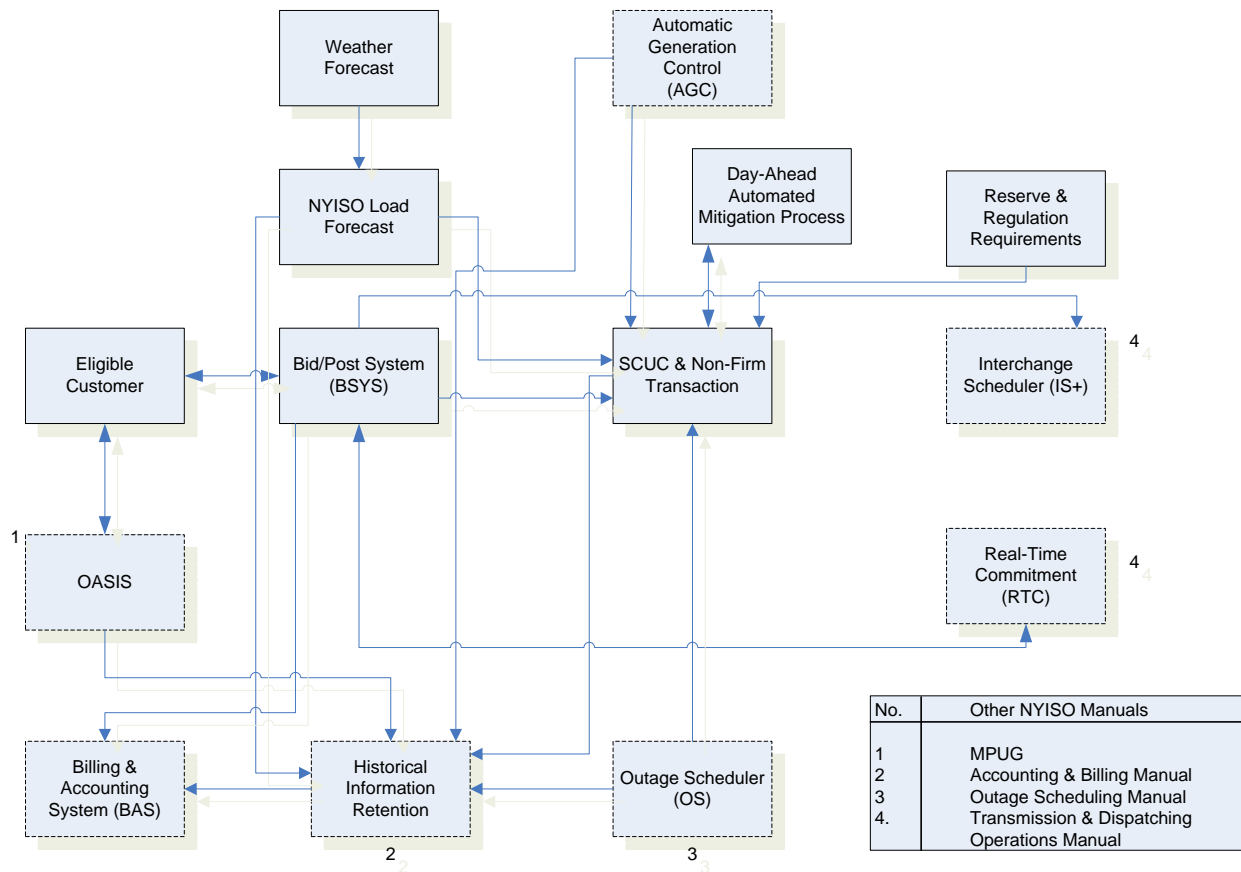

Figure 2-3: Day-Ahead Scheduling Data Flow

2.3.1 Primary Functions

The following is a brief summary of each primary function block (solid line) shown in Figure 2-3:

Weather Forecast – The Load Forecast function retrieves weather forecast data from the Weather Forecast data file maintained from data received from the weather service.

Load Forecast (LF) – The Load forecast function is used by the NYISO to forecast loads for each Zone in the NY Control Area. The LF function uses historical load and weather

data information for each Zone to develop forecast models. These models are then used together with Zonale weather [forecast](#) to develop a NYISO-based Zonale load forecast for the next seven days. This forecast is ~~saved to the Transmission Constraint Group (TCG) file. See Section 5 of this manual~~[this Manual for a description of the TCG file used in the reliability passes in SCUC.](#)

Reserve & Regulation Requirements – The following requirements are passed on to the ~~Security Constrained Unit Commitment~~[SCUC](#) program:

- Operating Reserve requirement for each category
- Regulation requirement

~~**Eligible Customers**—All market business and financial activities are between the NYISO and the Eligible Customers. Eligible Customers can be LSEs, GENCOs, or Power Exchanges. (i) Any electric utility (including the Transmission Owner and any power marketer), Federal power marketing agency, or any person generating Energy for sale or resale is an Eligible Customer under the Tariff. Electric energy sold or produced by such entity may be electric energy produced in the United States, Canada or Mexico. However, with respect to transmission service that the Commission is prohibited from ordering by Section 212(h) of the Federal Power Act, such entity is eligible only if the service is provided pursuant to a state requirement that the Transmission Owner offer the unbundled transmission service, or pursuant to a voluntary offer of such service by the Transmission Owner. (ii) Any retail customer taking unbundled transmission service pursuant to a state requirement that the Transmission Owner offer the transmission service, or pursuant to a voluntary offer of such service by the Transmission Owner, is an Eligible Customer under the Tariff.~~

~~**Bid/Post System (BSYS)**—The Bid/Post System allows Market Participants to electronically enter and send to the NYISO bids for dispatchable and fixed-schedule generation, transactions, and load. The Bid/Post System provides facilities for entering bids used in both the Day Ahead and the Real Time scheduling process.~~

~~[See NYISO OATT Section 1 Definitions and Section 3 this manual.](#)~~

~~Functionally, The~~The Bid/Post System allows Market Participants to review ~~certain~~ results of the Day-Ahead ~~and~~ ~~and~~ Real-Time scheduling, and dispatch processes. ~~Results available for review include~~ [including](#) accepted and rejected bids, generation schedules, and clearing prices. Confidential data is restricted to those entities that have authorized access.

The Bid/Post System provides the Day-Ahead scheduling information to the Real-Time Scheduling Subsystems.

Security Constrained Unit Commitment (SCUC) – The ~~Security Constrained Unit Commitment~~[SCUC](#) produces the generating unit commitment schedule and Firm Transaction schedules for the next day’s operation. Factors considered by SCUC are:

- Current generating unit operating status
- Constraints on the minimum up and down time of the generators
- Generation and start up bid prices
- Plant-related startup and shutdown constraints

- Minimum and maximum generation constraints
- Generation and reserve requirements
- Transmission facility maintenance schedules
- Transmission constraints
- Phase angle regulator settings
- Transaction bids

Non-Firm Transactions Evaluation – These transactions are not willing to pay congestion charges and therefore, they will not be scheduled if there is congestion. If there is no congestion these transactions are scheduled in NERC priority sequence within the Available Transfer Capabilities of the NYS Transmission System.

2.3.2 Supporting Functions

~~**Post Unit Commitment (PUC)**—The Post Unit Commitment function collects the Day-Ahead scheduling results, which include the commitment schedule, accepted generator and transaction bids (approved firm transactions), load bids, and operating limits. Other functional components access this data for various purposes.~~

The following is a brief summary of each supporting function block (dashed line) in Figure 2-3.

Historical Information Retention – Data required for archiving, billing and accounting, as well as information required to support auditing, is saved. Data that is stored includes results of the Day-Ahead scheduling study, interchange schedule information, RTD calculated base points for every **five minute** dispatch execution, equipment outage schedule information, zonal marginal prices, transmission rights information, actual reserves and reserve requirements, and actual system conditions.

OASIS – See the [NYISO Market Participant User's Guide](#) ~~NYISO Market Participant User's Guide~~ for details.

Billing & Accounting System (BAS) – The BAS function itemizes those data elements stored or generated by the various subsystems so that line item settlement statements can be calculated after the fact on a monthly basis. Billing information is limited to those market systems that are in place for the initial LBMP implementation. Data is captured for every dispatch cycle and saved for off-line calculation of pertinent billing information. All consolidated billing information is stored in the historical archives for subsequent processing. See the [NYISO Accounting & Billing Manual](#) for details.

Outage Scheduler (OS) – The Outage Scheduler function is used by the NYISO to keep track of scheduled equipment outages in the NY Control Area. The OS provides a user interface for entering equipment outage schedules, as well as reviewing existing schedules. Additionally, the OS records the actual status changes of the network equipment regardless of whether its status change was scheduled. See the [NYISO Outage Scheduling Manual](#) for details.

~~**Performance Tracking System**~~ **Automatic Generation Control (AGCPTS) Function** – The [AGCPTS](#) monitors the SCADA database for the on-line status of generating units and, when generating, the on/off status of their Automatic Voltage Regulator (AVR) equipment.

It also monitors ~~AGC~~ control performance. [See NYISO OATT Section 1 Definitions. Also See](#) the [NYISO Transmission & Dispatching Operations Manual](#) for details.

Interchange Scheduler (IS+) – The IS+ function allows NYISO personnel to monitor ongoing energy transactions. These transactions are bids accepted in either the Day-Ahead scheduling process or the ~~balancing market~~ [Real-Time](#) scheduling ~~and~~ /dispatch process. This program provides facilities for reviewing existing transaction information and for adjusting transactions in real-time to address security problems. The IS+ function produces the NY Control Area Desired Net Interchange (DNI). See the [NYISO Transmission & Dispatching Operations Manual](#) for details.

Real-Time Commitment (RTC) – After the Day-Ahead schedule is published and no later than 75 minutes before each hour, Customers may submit Real-Time Bids into RTC for real-time evaluation. The Day-Ahead scheduled transactions and the candidate Real-Time transactions are ~~screened~~ [evaluated](#) to assure that the interface [Available Total Transfer Capability \(TATCs\)](#) are respected. In addition, candidate External transactions are evaluated for LBMP economics against their decremental bids. [See NYISO OATT Section 1 for definition.](#) See the [NYISO Transmission & Dispatching Operations Manual](#) for details.

2.3.3 Data Flow

The following is a brief description of the data flow between the various Day-Ahead functions.

Bid Information – The Bid information that is passed to the Bid/Post System from the Market Participants is listed in the *NYISO Market Participant User's Guide*.

Posts Billing Information – The Bid/Post System is required to pass all schedules, pricing, and results to the Billing & Accounting System, on a daily basis.

Posts User Activities – All user access to the Bid/Post System function is logged and stored. Any data items entered or changed with the associated timing information, are stored for future tracking and auditing purposes. A complete duplicate of Bid/Post System information is retained.

Security Constrained Unit Commitment (~~SCUC~~) – The ~~Security Constrained Unit Commitment~~ [SCUC](#) saves the hourly output of each generator [for energy, reserves, and regulation.](#) ~~(for different categories).~~

Bid/Post System to SCUC – The SCUC program requires all of the validated bid information from the Bid/Post System. ~~Bilateral-External~~ Transactions are treated in the base case as generators and loads.

Automated Mitigation Process (AMP) – Automated mitigation relies on a second SCUC evaluation pass to assess the impact of mitigation; and a third SCUC pass to produce a final schedule. Thus, three SCUC pass evaluations are required. The first, pass 1A, determines the prices and schedules that would occur with the original set (Base-Set) of bids and offers. The second, pass 1B, determines the prices and schedules that would occur with conduct failing bids replaced with reference bids (Ref-Set). Differences between Base-Set and Ref-Set are used to determine price impact. The third Unit Commitment, pass 1C, determines final prices and schedules using mitigated bids and offers (Mit-Set) when both conduct and impact warrant mitigation.

~~*Hourly Generator Output*~~ — The ~~Post UC~~ function provides the Bid/Post System function with the output data associated with the Day Ahead scheduling study.

~~*SCUC to Post UC*~~ — The ~~SCUC~~ function provides the Post Unit Commitment function with the input and output data associated with the Day Ahead scheduling study. The ~~PUC~~ function compares the Bilateral Transactions with the results of the ~~Security Constrained Unit Commitment~~.

~~*Reserve and Regulation Requirements*~~ – The ~~SCUC~~ function obtains the following hourly requirements ~~for NYCA, Eastern New York and/or Long Island on a Transmission Constraint Group basis from the Energy Management System~~:

- Spinning 10-minute reserve
- Total 10-minute reserve (includes the spinning 10-minute reserve)
- Total operating reserve (includes the total 10-minute reserve and 30-minute reserve)
- Regulation capacity

~~*AGCPTS to SCUC*~~ – The ~~AGCPTS~~ function prepares a list of information that contains every generator and its last change of state.

~~*Bid/Post System to Interchange Scheduler*~~ – The Bid/Post System function provides evaluated transactions to the IS Plus function ~~with accepted transactions~~.

~~*Post SCUC to Bid/Post System*~~ – ~~Security Constrained Unit Commitment~~SCUC data is provided ~~by the PUC function~~ to the Bid/Post System, which then passes the information on to the Real-Time Commitment (RTC).

2.3. BID/POST SYSTEM

This section describes the Bid/Post System and its interfaces to other functions. [See NYISO OATT Section 1 Definitions.](#)

2.13.1 Bid/Post Functions

The Day-Ahead scheduling process begins when the Eligible Customers submit their Bids through the Bid/Post System. Eligible Customers provide bidding information to the NYISO for generation, load, and transactions; and review the posted results such as accepted bids, generation schedules, and clearing price information.

The primary data exchanges of the Bid/Post System for the Day-Ahead scheduling function include the following:

- Eligible Customers enter Day-Ahead bids
- NYISO posts accept/reject information of bid data for Day-Ahead scheduling.
- NYISO posts marginal pricing information
- NYISO posts historical results (limited capability)
- NYISO posts [the list of generators that are general NYISO status to all Market Participants such as performing unscheduled commitment committed for reliability under Operational Announcements on the ISO website.](#)
- NYISO posts current operating parameters in the hour of use
- Market participants review and revise operating information.

NYISO posts audit trail of information by user and time stamp.

2.23.2 Bid/Post Process

The following classifications of data exist for the Bid/Post System:

- Generator, LSE, and Bus Data (Private)
- Bid Data (Private)
- Posted Schedules/Other (Private)
- Posted Prices/Other (Public).

For consideration of confidential information, the first three types of data have access limited to registered Market Participants who have a right to review such information. The fourth type of data is accessible to all the registered users of the Bid/Post System.

Data Classifications

Detailed data tables of each parameter of the four data types are included in the *NYISO Market Participant Users Guide*.

- **Generator, LSE, and Bus Data** – Certain unit information such as upper operating limits, minimum generation levels, and normal and emergency response rates require NYISO confirmation to become valid. The parameters, to be entered by the NYISO into the Bid/Post System, may require supporting information such

as certification and testing. The NYISO provides status flags for the unit indicating what types of bids the unit has been qualified to submit.

LSE information required is similar to the ownership requirements of a generator and is supplied by a LSE's designated administrator and the NYISO. The NYISO provides the bus, sub-zone, and Zone identifications for the LSE territory, which the LSE serves.

Bus data includes information supplied by the NYISO, including reference names, numbers, sub-zone, Zone, and other designations used by Market Participants to identify a bus ~~and for NYISO applications such as Unit Commitment and Real-Time Commitment.~~

Almost all of the above data is considered static, in that it is not expected to change frequently and certain pieces require different levels of NYISO certification or user verification to enter and change.

- **Bid Data** – LBMP Market Participants enter bid data parameters for generators, ~~Bilateral-External~~ Transactions, and load for the Day-Ahead ~~M~~market. Users may change data already validated or submit new data for validation up to the close of the market period when evaluation of validated bids starts. Authorized users have the capability to review and modify current operating parameters (Real-Time Market) in the hour of use.

Bid data includes timing information such as when a bid becomes valid and when it expires.

- **Posted Schedules/Other (Private)** – The sets of schedules and prices posted under LBMP result from ~~Security Constrained Unit Commitment (SCUC) and Real-Time Commitment Scheduling (RTCRTS).~~ As schedule information is considered confidential in nature, only registered users with authorization have the right to review their schedules or rejection notices associated with their bids.

In general, after completion of the Day-Ahead scheduling process; generation schedules, load forecasts, day-ahead LBMP prices (including congestion and loss components) for each load zone in each hour of the upcoming day, and scheduled ~~Bilateral-External~~ Transactions are posted to bidders.

In RTC, updated load forecasts, and additional ~~ExternalBilateral~~ Transactions are evaluated. In the Bid/Post System, generator schedules are posted and LBMP bus prices calculated by RTC for the next hour are advisory in nature only. Prices used in billing are determined in the real-time market by RTD. RTC posts accepted ~~ExternalBilateral~~ Transactions for the next hour also.

- **Posted Prices/Other (Public)** – Data that is posted as public implies that any user of the Bid/Post System is able to access the information (unregistered users do not have access to the Bid/Post System).

The bus and zonal LBMP prices are posted after Day-Ahead commitment, after RTC, and hourly RTD results. Clearing prices for reserves are posted, and advisory NYISO load forecasts are also posted. The Bid/Post System retains this information for Market Participant review for a specified period of time (initially, 15 days). After expiration of the time interval, the Bid/Post

System audit data will be only accessible through the Historical Information System. The daily Bid Production Cost Guarantee ([BPCG](#)) in aggregated total dollars from both the Day Ahead and Real-Time Markets is [Posted-posted](#) as Public Data.

The Bid/Post System provides capability for [issuing](#) general messages from the NYISO, such as when the NYISO is performing a supplemental commitment.

Validity Checks

The data submitted to the Bid/Post System is checked for validity, [with](#) bidder notification that [a](#) bid has been validated as soon as possible. If a bid is rejected because part of [the](#) data is not valid, a posting for the bidder indicates the problem and gives an opportunity to resubmit [a](#) modified bid providing the market has not closed.

Bid validity is broken into the following different types of validation checks:

- **Ownership (O)** – Ownership recognizes the bidder as having the authority to bid a particular service, such as owner of a generating plant bidding energy services.
- **Completeness (C)** – Completeness indicates that the bidder has entered all the required parameters for a particular bid to be evaluated, such as regulation bids providing regulation response rate, available capacity, and dollars per MW availability.
- **Individual Data Checks (I)** – Individual data checks look at constraints placed on individual data parameters either universally applied to a given field or constrained by qualification data, such as upper operating limit (energy bid) not exceeding the maximum operating limit of a unit.
- **Relationship (R)** – Relationship checks look at the interdependence of certain parameters supplied to the Bid/Post System.
- **Special Relationship (SR)** – Special relationship checks look at bid parameters relative to other parameters that have not been supplied with a particular bid, such as [ExternalBilateral](#) Transaction waiting for other party confirmation, or real-time energy market bid price not exceeding Day-Ahead bid for portion committed.
- **[Prohibited Transmission Paths](#)** – [Prohibited transmission paths checks filter out External Transaction schedules submitted over the eight prohibited circuitous scheduling paths. See OATT Attachment J, Section 16.3.3.8 for definitions of those scheduling paths.](#)

Notifications

There are many different types of notifications that the Bid/Post System provides to users concerning the status of a particular bid. The currently defined notifications are as follows:

- **Validation** – Data entered through the Bid/Post System is identified as being either validated, rejected with message indicating why rejected, or a status of the validation process. For validated bids the status message is VALIDATION PASSED. For invalid bids the status indication is VALIDATION FAILED, with a message indicating reason for failure, such as one of the validation rules. The status of the validation process is only used in a special case and discussed as the next type of message notification.

- **Confirmation** – When the validation process cannot be continued because information is needed that is not submitted with part of a particular bid (e.g. certain Special Relationship checks), the indication would be WAITING CONFIRMATION. Confirmation messages identify the organization required to supply the necessary information needed for the validation process such as confirmation of [an External Bilateral Transaction](#). It is important to note that some of the Special Relationship checks, performed during the Day-Ahead and Real-Time Commitment evaluation periods, are not considered part of the validation procedure. Rather, these are identified as acceptance criteria and used with acceptance notification. For a bid or offer to be evaluated by Day-Ahead or Real-Time Commitment, it must have a status of VALIDATION PASSED.
- **Acceptance** – During the time that the NYISO is using bids to perform commitment or real-time market evaluation, the status of a bid is shown as EVALUATING. After evaluation is complete, the results are posted and the status of the bid is tagged as BID ACCEPTED, MODIFIED, CONDITIONALLY ACCEPTED, BID REJECTED, or ADVISORY ACCEPTED. In the event that a supplemental resource evaluation is required, bids that have not reached expiration time; will be considered available for evaluation and will not be allowed to expire. For example, a bid to supply energy is due to expire at 11:00 ~~p.m.~~ PM. The NYISO begins an SRE at 10:40 ~~p.m.~~ PM to address an energy concern at 07:00 ~~a.m.~~ AM the following day. The bid would be utilized in the SRE evaluation.
- **Result Posting** – All accepted bids will have resulting schedules posted. The Bid/Post System clearly identifies bids that have forward contracts and those that are advisory. Included in the results posting is the ability for the user to review the past bids and results for Day-Ahead Unit Commitment, supplemental unit commitments, Real-Time Commitment, and actual operating results for a specified period of time.

Tracking & Auditing

Tracking and auditing serves the NYISO and the Market Participants. All information in the Bid/Post System is retained for auditing purposes. Limited information from the Bid/Post System on past bids and results is available to the Market Participants. All inserts, updates, and deletions to the Bid/Post System are tagged with date, time, and user identification. The audit trail is provided with table log files.

User Interface

Not all Market Participants have the same capabilities and needs for interfacing with the Bid/Post system. In order to provide convenient interface options, a number of methods for supplying data and also for reviewing results are supported. The following describes these interface methods.

- **World Wide Web** – The Bid/Post System is accessible through public Internet Web pages, utilizing hardware and software similar to that used for the OASIS System. Market Participants are able to submit data and review postings through Web pages using this method.

- *Upload/Download* – Upload and download file capabilities are provided to Market Participants, utilizing hardware and software similar to that used for OASIS. File formats or templates for these files are supplied to Market Participants.

2.33.3 Bid/Post Interfaces

The data exchange for each application is outlined as follows.

2.3.13.3.1 SCUC & Post Unit Commitment

The ~~Security Constrained Unit Commitment~~ SCUC program has all the validated bid information when the Day-Ahead market closes. The schedules resulting from Unit Commitment are sent back to the Bid/Post System ~~through a second component referred to as Post Unit Commitment.~~ ~~The Bid/Post System and SCUC exchange information handles bi-directionally data exchange with both SCUC and PUC.~~

2.3.23.3.2 Interchange Scheduler

The Bid/Post System sends approved transactions to the IS+ package. When there is a change in transactions the IS+ updates the Bid/Post System.

2.3.33.3.3 Real-Time Commitment Scheduling

The Real-Time ~~Commitment Scheduling~~ requires all new market bid information from the Bid/Post System and approved schedules from SCUC. The results of ~~RTC RTS~~ are sent back to the Bid/Post System. Data exchange is bi-directional between the Bid/Post System and ~~RTCRTS~~.

2.3.4 LBMP Calculation

~~The Locational Based Marginal Pricing calculates hourly bus and zonal clearing prices that are provided to the Bid/Post System. Data exchange is uni-directional from LBMP to the Bid/Post System.~~

2.3.53.3.4 Performance Tracking System

The Performance Tracking System provides hourly performance measurements to the Bid/Post System. When available, Data exchange is uni-directional from the PTS to the Bid/Post System.

2.3.63.3.5 Billing & Accounting System

The Bid/Post System is required to pass all schedules, pricing, and results to the Billing & Accounting System. Data exchange is uni-directional from the Bid/Post System to the BAS.

The Billing & Accounting (BAS) function itemizes those data elements stored or generated by the various subsystems, from which line item settlement statements

are calculated ~~after the fact on a monthly basis~~. Refer to the ~~NYISO Accounting & Billing~~NYISO Accounting & Billing Manual for a detailed description.

~~2.3.73~~.3.6 **Historical Information Retention**

All relevant Bid/Post System information is saved.

~~2.3.83~~.3.7 **OASIS**

Refer to the *NYISO Market Participant User's Guide* for a description of the interface.

~~2.3.9~~ **Loss Calculation**

~~Power losses occur in the transmission system as energy flows from generation sources to the loads. These losses appear as additional electrical load, requiring the generators to produce additional power to supply the losses. Losses are usually included within load forecasts. The amount of losses that occur on specific transmission lines or areas of the transmission network at any given time is dependent on the specific generation sources being used to meet the load at that time. Attachment A of ~~this manual~~this Manual defines the calculation of incremental transmission losses.~~

~~Where required, Penalty Factors are converted to Delivery Factors:~~

$$~~Delivery Factor = 1 / (Penalty Factor)~~$$

3.4. DAY-AHEAD SCHEDULING PROCESS

This section focuses on the Day-Ahead scheduling process for the LBMP implementation. The Day-Ahead scheduling process establishes Day-Ahead schedules ~~and forward contracts~~ including ~~generator schedules, and External Bilateral~~ Transaction schedules. This is accomplished by the following procedures:

- Assembly of the Day-Ahead outages
- Production of a preliminary NYISO zonal load forecast
- Execution of ~~Security Constrained Unit Commitment~~ SCUC
- Tabulation and evaluation of transactions.

3.14.1 Day-Ahead Inputs & Outputs

Inputs to Day-Ahead Scheduling

The primary inputs to the Day-Ahead scheduling process are:

- Transmission outage list from the ~~outage scheduling file~~ Energy Management System (EMS)
- Weather forecasts
- Load forecast model
- ~~LSE load forecasts by zone from the Bid/Post System (saved on the TCG file)~~
- Validated firm ~~bilateral External transaction~~ Transaction requests from the Bid/Post System (converted to generation and load)
- Operating Reserve and Regulation requirements ~~from the EMS (Saved on the TCG file)~~
- Validated Day-Ahead generator bid data from the Bid/Post System
- Validated Day-Ahead load bids from the Bid/Post System
- Price capped load ~~and interruptible load~~ bids from the Bid/Post System
- Validated non-firm ~~External bilateral t~~ Transaction requests from the Bid/Post System
- Validated virtual generation and virtual load bids from the Bid/Post System
- Lake Erie circulation assumptions

Outputs from Day-Ahead Scheduling

The primary outputs from the Day-Ahead scheduling process are:

- Updated Total Transfer Capabilities (TTCs) posted on OASIS
- Firm ~~and Non-Firm~~ Available Transfer Capabilities (ATCs) posted on OASIS
- PAR Flows posted on OASIS
- Day-Ahead Limiting Constraints posted on OASIS
- ~~Approved and rejected bilateral transactions posted on the Bid/Post System~~
- Commitment schedule for generation ~~and bid~~ load resources, operating reserves, regulation, External Transactions and ~~non-bid~~ load posted on the Bid/Post System and transaction evaluation for First Settlement

- Market Clearing Prices for operating reserves and regulation posted on the Bid/Post System
- ~~Commitment schedule for generation and load for First Settlement posted on the Bid/Post System and transaction evaluator~~
- First Settlement LBMPs posted on the Bid/Post System ~~and transaction evaluator~~
- Zonal load forecast posted on the Bid/Post System.

3.24.2 SCUC Initialization

The next subsections describe the initialization that is performed in preparation for SCUC.

~~3.2.1 Assemble Day-Ahead Transmission Outages~~

~~The outage process for transmission facilities involves the following procedures:~~

~~Preparation of a facility outage flat file~~

~~Preparation of the updated SCUC model, which is used by the SCUC function.~~

~~3.2.24.2.1 Preliminary Day-Ahead Zonal Load Forecast~~

The NYISO prepares a ~~preliminary Day-Ahead~~ zonal load forecast ~~using the Artificial Neural Network (ANN) methodology~~. This NYISO forecast is independent of the LSEs' forecast. The procedure for NYISO forecasting is as follows:

- ~~Retrieval Assembly~~ of ~~actual and historical~~ weather data ~~by Zone based on the daily and~~ weather forecasts obtained from the weather service
- Retrieval ~~of of the load forecast model including~~ historical load data
- Execution of the ~~ANN~~ load forecast program
- ~~Saving Transferring of~~ the NYISO load forecast ~~data to the TCG file for use by~~ SCUC.

~~4.2.2 Assemble Day-Ahead Transmission Outages~~

~~The outage process for transmission facilities involves the following procedures:~~

- ~~Transfer of the transmission outages from the EMS~~
- ~~Preparation of the updated SCUC model, which is used by the SCUC function.~~

~~3.2.34.2.3 Initial Generator Status and Commitment Rules~~

The ~~Performance Tracking Automatic Generation Control~~ System produces a list of actual generator start and stop times and dates. This start and stop information is ~~saved transferred to the unit commitment history file for later~~ use by the ~~Security Constrained Unit Commitment~~ SCUC process.

In preparation for the start of a unit commitment study, the SCUC input processor updates generating unit statuses.

Initialization Status

When SCUC initializes at ~~05:00 a.m.~~ for the following day, the statuses of the units that bid into the Day-Ahead Market (DAM) are based on their current operating mode at the time of initialization, with modifications. The modifications are the projected changes for the remainder of the day from the previous day's DAM schedules. If a unit is not in the mode that SCUC expects it to be at the time of initialization, the current mode of the unit overrides the projected change. No units are considered "must run" in SCUC.

Startup Time

Either a startup versus downtime curve or a notification time can be provided for SCUC. If both are provided, the startup versus downtime curve overrides the notification value.

SCUC posts the results for the next day's DAM at 11:00 ~~a.m.~~ a.m. If a unit is down at posting time, the startup time is measured from the time of posting. The unit is recognized as unavailable until the startup notification period has elapsed.

If a unit is running but projected to come down after posting time, a bid for the unit in SCUC indicates that it is willing to operate. Neither a startup versus downtime curve nor a notification time value is recognized.

Minimum Run Time

In SCUC, the minimum run time is honored within the 24-hour evaluation period only; requirements across midnight are not recognized. (except to the extent they are reflected in a late day start Bid). A unit must bid appropriately to enable commitment in the next day.

Minimum Down Time

SCUC honors the minimum down time within the 24-hour evaluation period only; requirements across midnight are not recognized. A unit must bid appropriately to preclude commitment in the next day.

4.2.4 Scheduling a "Must Run" Generator

There is no such thing as a "Must Run" generator. To improve the chances that a generator is scheduled into the market, it must be offered such that it is positioned at the bottom of the economic bid curve.

A generator that desires a commitment to operate might not be scheduled due to system constraints or reliability rules. For example, if a set of generators are running to meet a particular load and all the generators are operating at their minimum generation level, then no other generator would be started, even if the new generator is otherwise economic (less costly, on an incremental basis, than the generators that are already operating). Also, if a generator is constrained for transmission security, then it may not be scheduled to run, or it may be scheduled at a reduced amount, by Security Constrained Unit Commitment (SCUC) and Real-Time Commitment (RTC). To increase the probability that a generator will be scheduled into the market, it must be bid at the bottom of the economic dispatch

curve. The following presents a few simple guidelines to increase the chances otherwise available that a generator would be economically scheduled.

Bid a “Start-Up Cost” of Zero Dollars

Market Participants may enter zero dollars into the “Start-Up Cost (\$)” field on the Generator Bid screen in the MIS. This will prevent the SCUC or RTC from considering start-up cost.

Submit a Low Minimum Generation Bid

SCUC and RTC minimize total production costs over their respective evaluation periods. The Minimum Generation Costs are factored into this evaluation; therefore a low value in this field will increase the likelihood that the unit will be scheduled to run based on economics.

Submit a Low Incremental Energy Bid

The dispatch curve is used between the minimum and upper operating points to dispatch the unit. If not the marginal unit, a generator will receive the higher Locational Based Marginal Price at its bus, regardless of its bid. If many generators are vying for a “must-run” schedule within an area, a negative bid may prove necessary to be scheduled, especially if others are bidding negative. However, when bidding a negative value, the generator risks setting the price and having to pay to operate. Also, the SCUC and RTC software minimize production costs over multiple hours, so all hours must be strategically bid together. For example, the hourly bids of a unit would be evaluated over all the hours that it could be scheduled, given its minimum run time or down time constraints.

Use Appropriate Static Generator Parameters

In the SCUC Day Ahead Market, all static generator parameters are used based on the unit’s initialization. Generators that bid into the non-synchronous reserve market will not have their unit scheduled for energy if their bid is accepted in the non-synchronous reserve market. The generator may change this value by going to the Generator Commitment Parameters in the Market Information System.

Outage Schedule Utilization

In addition, a unit must not be listed in the NYISO Outage Scheduler as an outage or a deration, since this will override the bid values and will prevent RTC from scheduling the unit above its reduced maximum output. If a unit is no longer on forced shutdown or derated, the generator must notify their Transmission Owner, who will then notify the NYISO operator. Notice must be given 75 minutes prior to an hour for RTC to evaluate the unit.

Submit a Bid in Self-Committed Fixed Mode

By submitting a bid in Self-Committed Fixed mode, a unit will be dispatched to the level indicated in the bid, subject to system security. Although submitting a bid in Self-Committed Fixed mode cannot guarantee the commitment of a unit, there is a high possibility that the unit will be committed in SCUC. However, a unit bidding as Self-Committed Fixed is not eligible to submit any cost curve, so it can be scheduled regardless of the low LBMP it will get paid.

4.2.5 Multiple Response Rates for Generating Units

Each generation unit modeled in the Market Information System (MIS) may specify up to five response rates. Three response rates are available for following basepoints in the energy market, the emergency response rate is available for providing operating reserve pick-up, and the regulating capacity response rate is available for regulation service.

In an effort to encourage generating units to place themselves in Flexible mode, multiple response rates that more accurately reflect a unit's response capability may be specified. The energy and emergency response rates may be specified for up to three energy supply ranges. For example, the Minimum Generation MW-50MW range may have a 0.2 MW/minute response rate, the 51-150MW range may have a response rate of 8 MW/minute, and the range from 151MW to the maximum upper operating point may have a response rate of 2.2 MW/minute. Defining the three energy ranges and the response rate for the ranges is at the discretion of the generator. It is the generator's responsibility; however, to ensure that the response rates specified are within the capability of the unit, provided, however, response rates that differ from those specified in the ISO Tariffs based on the capability of the unit shall be reviewed and accepted by the NYISO. The NYISO will maintain the response rates currently shown in the MIS for the unit until the changes are accepted.

The SCUC and RTC programs, which perform Day-Ahead and Real-time scheduling calculations respectively, use the explicit response rates for each megawatt segment.

Regulation bids must be structured such that the unit's specified capacity response rate is valid for the bid submitted. For example, a regulation capacity bid of 30MW must be supported by a regulation capacity response rate of 6 MW/minute over the 5-minute RTD interval to fully comply with regulation provider responsibilities. The regulation capacity response rate must not be slower than the slowest energy or emergency response rate.

The emergency response rate specified for a unit will be used during a reserve pickup condition when RTD-CAM moves the unit towards its emergency upper operating limit. Neither the emergency response rate nor the regulating response rate will be used as additional energy response rates **in any dispatch other than that.**

The three energy response rates and the emergency response rate must be specified in increments such that they will result in an integer MW amount over an RTD interval. In other words, response rates with an odd decimal place (i.e. .1, .3, .5, .7, or .9) are not allowed. The minimum response rate allowed for energy and the emergency response rate is 0.2 MW/minute. The minimum capacity response rate allowed for regulation is 1 MW/minute.

Market Participants interested in specifying multiple energy response rates for a generating unit(s) must set this up by contacting their Stakeholder Services Representative.

4.2.6 Day Ahead Reliability Unit (DARU) Commitment

Background

Transmission Owners regularly request that the NYISO commit additional resources to meet the reliability needs of their local systems. Recent changes allow the NYISO to commit these resources in the Day-Ahead Market when notified of the need to do so by the Transmission Owners. Since a Day-Ahead commitment of these resources produces a more efficient commitment than a commitment following the Day-Ahead market run, Transmission Owners should notify the NYISO of the need for these resources by 01:00 a.m. prior to the Day-Ahead Market close, to allow for input into the system (e.g., a request for Saturday must be communicated to the NYISO by 01:00 a.m. Friday). Those units that the NYISO commits solely for reliability reasons at the request of a Transmission Owner or for statewide reliability needs as initiated by NYISO, are known as Day-Ahead Reliability Units (“DARU”).

Transmission Owner Requests for DARUs

When requesting the commitment of a reliability-necessary unit for the Day-Ahead market, TOs must give the NYISO the reliability reason for the request, the expected duration of the need, and the specific facility or constraint affected. TOs should request a DARU for all generating units needed for reliability of their local system to ensure against economic decommitments. NYISO operators will log all such TO requests. (This is consistent with the requirements that apply to TO SRE requests.) Within 5 business days, the TO requesting the reliability commitment shall provide detailed written justification for the DARU request to SREinfo@nyiso.com. The NYISO will review all these requests to ensure that practices being followed are consistent with NYISO tariffs and NYS Reliability Rules.

The TO's written justification must detail the system conditions that resulted in the need for the reliability commitment such that the NYISO can independently verify the request. The following system conditions should be identified when applicable: TO local area or regional load levels; thermal transmission facility or substation voltage constraint; whether the constraint represents a predicted pre-contingency or post-contingency violation; significant transmission or generating unit outages affecting such constraint; and special local reliability criteria. Any additional local area system conditions that resulted in the need for the DARU commitment should also be identified.

All requests by TOs to commit generators via the DARU process, as well as NYISO-initiated DARUs, will be posted to the OASIS at the time of Day-Ahead Market close. For units located in Zone J (New York City), non-binding, advisory postings will be made at the time of DARU entry, modification, or deletion, in addition to the posting at Day-Ahead Market close.

An e-mail notification will also be sent to a DARU generator's contact, as entered in the Market Information System, when the Day-Ahead Market closes, indicating that the unit has been requested for Day-Ahead reliability. For units located in Zone J (New York City), a supplemental process will be used whereby a non-binding, advisory e-mail will be sent for every creation, modification, or deletion of a DARU entry by NYISO Operators. The Generator's contact may reach out to the requesting TO when there are constraints preventing the unit from being able to meet the commitment requested. If there are issues with TO communication, the Generator's contact may also reach out to inform the NYISO Grid Operations Department regarding the constraints.

NYISO Processing of Day-Ahead Reliability Unit Requests

SCUC optimizes offers and bids over the dispatch day to preserve system reliability and ensure that sufficient resources are available to meet forecasted load and reserve requirements. When a Transmission Owner notifies the NYISO of the need for a reliability unit, SCUC will first evaluate the generator for possible economic commitment. If economic, the unit's commitment will not be considered a reliability commitment. Commitment for reliability reasons renders the unit a DARU. A DARU request by a Transmission Owner or by the NYISO may override a generator's startup notification time.

3.2.44.2.7 Phase Angle Regulator Scheduling

Phase Angle Regulators (PARs) are scheduled in SCUC as follows:

- 1) Except for the conditions listed in Item #2, #3, #4 and #5 below, Day-Ahead PAR schedules to be input into SCUC will match the ~~previous like~~current day schedule for each PAR internal to or bordering the NYCA.
- 2) If PAR scheduling changes are anticipated or maintenance facility outages are scheduled which affect PAR operation, Day-Ahead PAR schedules to be input into SCUC are modified in accordance with published contractual agreements and/or operating procedures.
- 3) PARs that have been designated to be under NYISO operational control are optimized by SCUC along with other resources. The optimization allows adjustments to the original schedules of the PARs to help relieve energy transmission into congested areas.
- 4) The desired flows will be established for the ABC, JK, and 5018 interconnections based on the following, pursuant to OATT Section 35, Attachment CC – JOA Among and Between NYISO and PJM, Schedule C and Schedule D:
 - The ABC interconnection will be scheduled on the Consolidated Edison Company of New York's Day-Ahead Market hourly election for the "600/400MW Contracts" plus an adjustment of up to 13%0% of PJM-NYISO Day-Ahead Market hourly interchange
 - The JK interconnection will be scheduled on the Consolidated Edison Company of New York's Day-Ahead Market hourly election for the "600/400MW Contracts" plus an adjustment of up to 13%0% of PJM-NYISO Day-Ahead Market hourly interchange

- The Branchburg-Ramapo interconnection will be scheduled to carry 40% of the PJM-NYISO hourly interchange. The Branchburg-Ramapo 500kV Operating agreement allows for the assumption that up to 61% of PJM-NY transaction schedules flow over the 5018 interconnection. However, flows over the 5018 interconnection will be conservatively modeled at 40% to ensure feasible operating schedules. In any case, the schedule on Branchburg-Ramapo interconnection will not exceed the rating of 5018. The desired flow scheduled over the Branchburg-Ramapo interconnection may be adjusted by an offset MW value to reflect expected operational conditions.
- 5) The Northport PAR which is in series with the 1385 Northport-Norwalk Harbor transmission facility has been superseded by the 1385 Proxy bus in the scheduling systems.
- 3)6) PAR Schedules to be input into SCUC and SCUC results are posted by the NYISO.

3.34.3 Security Constrained Unit Commitment

The ~~Security Constrained Unit Commitment (SCUC)~~ SCUC function is used in the LBMP implementation to produce the generating unit commitment schedules, reserve and regulation market schedules, and firm transactions schedules for the First Settlement.

3.3.14.3.1 SCUC Stages

The intent of SCUC is to develop a schedule using a computer algorithm that simultaneously minimizes the total Bid Production Cost of:

- 1) Supplying power to satisfy all accepted purchasers' Bids to buy Energy from the Day-Ahead Market.
- 2) Providing sufficient Ancillary Services to support Energy purchased from the Day-Ahead Market.
- 3) Committing sufficient Capacity to meet the NYISO's Load forecast and provide associated Ancillary Services.
- 4) Committing sufficient Capacity to meet the NYISO's Load forecast and Local Reliability Rule requirements.
- 5) Meeting all Bilateral Transaction schedules submitted Day-Ahead.

To meet the above requirements, the SCUC algorithm is designed as a ~~five~~ multiple pass process in which ~~three~~ two security constrained commitment passes and two security constrained dispatch passes are executed in sequence as follows:

Pass #1 – Bid Load, Virtual Load, and Virtual Supply Commitment

The first pass of SCUC ~~solves for~~ commits and schedules generating units, including units nominated to be Day Ahead Reliability Units, to supplying the Bid Load (Physical and Virtual) less Virtual Supply while ~~and~~ securing against the normal NYISO bulk power transmission system. The system is secured against the normal NYISO bulk power system contingency set so that ~~and~~ monitored facilities do not become overloaded. Also, the program secures for certain Local Reliability Rules² contingencies and monitored facilities.

Once this commitment run has converged, the automatic market power mitigation evaluation is performed ~~for the energy price caps~~, including a recommitment/redispach. This commitment/dispatch is evaluated by security analysis. Additional iterations of unit commitment ~~(with market power mitigation price caps)~~ bids and security analysis are performed until convergence is again achieved.

Pass #2 – Bulk Power System Forecast Load Commitment

The next pass ~~solves~~ commits any additional units that may be needed to ~~for~~ supplying the forecast load. Load bids (physical and virtual) and Virtual Supply bids are not considered in Pass #2. At the beginning of this pass, generator limits and commitment statuses are modified to ensure that the units selected in ~~the bid load~~ Pass #1 will not be de-committed or dispatched below their Pass #1 value. Generating uUnits selected in ~~the bid load~~ Pass #1 ~~may~~ can be dispatched higher, and additional units ~~can~~ may be committed and dispatched. Since Pass #2 is used to assure that sufficient ~~This pass evaluates for~~ capacity is committed to supply forecast load it considers only, and therefore uses incremental uplift costs and does not ~~consider~~ use energy costs. when determining additional commitments. Pass #2 also ~~This second commitment supplies the forecast load and secures against the bulk power system contingencies and monitored facilities.~~ In Pass #2, only the wind energy forecasts are used for scheduling intermittent resources that depend on wind as their fuel.

Pass #3 – Local Reliability Rules Forecast Load Commitment Reserved for future use

~~The final commitment is performed in this pass as an extension of Pass #2. The program secures for the Local Reliability Rules contingency and monitored facilities.~~

Pass #4 – Forecast Load Redispatch

In ~~this~~ Pass #4, the set of generators from the final commitment is dispatched using the original energy bids. The dispatch supplies the forecast load and is limited by the bulk power system constraint set produced in the Pass #2 commitment. The unit capacities (energy + 30 minute reserve + regulation capacity) from this dispatch are used to calculate the forecast reserve for economic dispatch. The power flows are created for the transmission providers' review and the interface transfer flows to be evaluated in the non-firm transaction selector.

Pass #5 – Bid Load, Virtual Load and Virtual Supply Redispatch

In ~~this~~ Pass #5, the final dispatch is determined to supply the bid load, virtual load and virtual supply (where virtual supply is treated as negative virtual load) and is limited by the ~~bid~~ constraint set produced in the Pass #1 commitment. The quick start units selected in ~~either of~~ the forecast ~~runs~~ pass will not be ~~not~~ dispatched Day-Ahead. ~~After this dispatch, the market power mitigation process is run to evaluate reserve price caps.~~

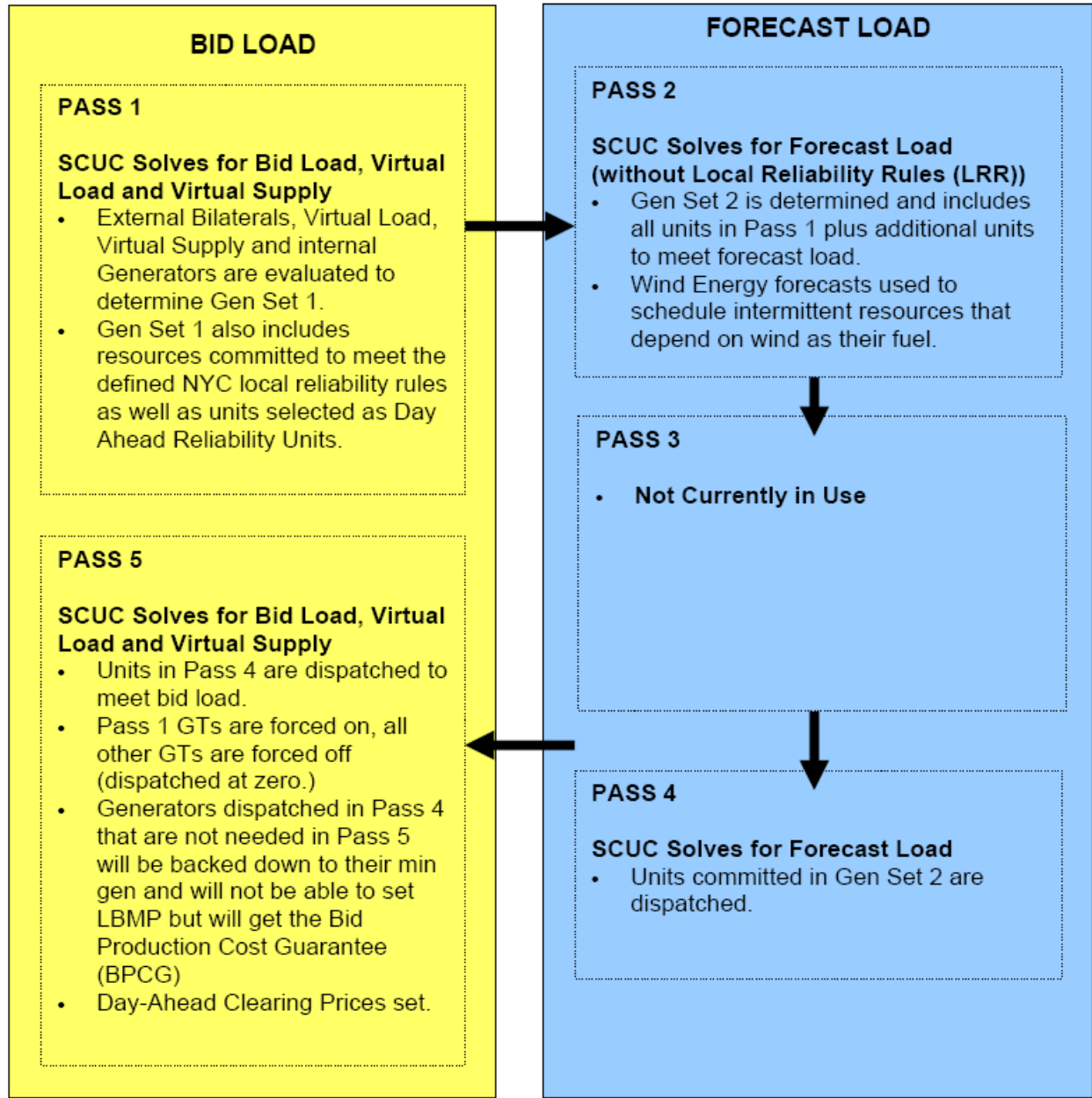

Figure 4-1: Multi-Pass Solution Process

Forecast Required Energy for Dispatch (FRED)

Forecast Required Energy for Dispatch (FRED) represents resources needed to serve internal load, which did not bid in Day-Ahead, but which is nevertheless forecast by the NYISO. Thus, "FRED" is additional expected energy needed to meet the NYISO forecasted load that is in excess of the sum total of Day-Ahead load bids. For each hour, FRED should at least equal the NYISO NYCA Load Forecast minus the Sum of Day-Ahead Internal Load Bids and Bilateral Schedules with Internal Sinks import transaction schedules.

FRED Eligibility

All suppliers bidding into the Day-Ahead and Real-Time Energy Markets automatically qualify as potential suppliers of FRED (Day-Ahead or supplemental FRED respectively).

FRED Selection

Day-Ahead FRED is selected by SCUC. Non-committed suppliers selected to provide FRED are notified via the MIS if they are anticipated to start-up during the commitment day but do not receive a forward contract to start-up.

FRED Payment Rules

As with other suppliers, once a FRED supplier is started:

- 1) Supplier is guaranteed recovery of its start-up bid price and minimum generation bid price bid through the remainder of the dispatch day subject to mitigation as appropriate.
- 2) Supplier may set and is paid the Real-Time Energy LBMP for actual energy supplied. No availability is paid for FRED.

As is the case for all Real-Time energy suppliers including FRED, an applicable NYISO penalty is assessed to FRED suppliers for failure to provide energy.

3.3.24.3.2 SCUC Components

The SCUC function consists of the following major components:

- Initial Unit Commitment
- Network Data Preparation
- Network Constrained Unit Commitment.

Initial Unit Commitment (IUC)

The initial unit commitment (IUC) function computes the initial unit commitment schedule based upon:

- The load and generation bid data from the Bid/Post system
- Unit status data derived from the ~~performance tracking~~ Automatic Generation Control system (AGCPTS)
- Current schedules
- Load forecasts
- ~~New York Interface constraints~~

~~An input processor takes the flat files from~~ Bid data is transferred from the Bid/Post system ~~and loads them~~ into the RANGER ~~IUC~~ database. ~~This data includes~~ ~~input processor also keeps track of~~ time stamps associated with the Bid/Post system data. IUC then runs with the newly loaded database as input and produces the initial unconstrained unit commitment schedule.

Network Data Preparation (NDP)

The network data preparation (NDP) function provides an automated procedure to set up the initial conditions and various parameters of power flow cases, i.e., base

cases, corresponding to the specified study period. It also validates the cases by calculating the power flow solution. A case is acceptable only when its power flow solution is successfully solved. NDP has the following essential components:

- ***NPD Controller*** – successively sets up the NDP case for each time step in the study and stores the resulting power flow solutions for subsequent processing
- ***Schedule and Limit Retrieval*** – for in/out-of-service equipment, and corresponding breaker statuses
- ***Network Model Builder*** – determines the network topology in the form of a bus model
- ***Bus Scheduler*** – sets up the power flow case
- ***Load*** – distributes system load to individual buses
- ***Voltage Regulation*** – assigned to the regulating devices
- ***Generation*** – economic dispatch for units (such as external) that are not considered in the initial unit commitment
- ***Dispatcher Power Flow*** – develops a base case power flow solution to detect data anomalies and to validate the initial unit commitment schedule.

Network Constrained Unit Commitment (NCUC)

The network constrained unit commitment (NCUC) function calculates a generation schedule for a specified study period, making sure that both unit commitment constraints and network security constraints are satisfied. NCUC has the following essential components:

- ***NCUC Controller*** – coordinates the NCUC solution process consisting of the following iterative steps:
 - Retrieve initial base cases and superimpose schedules from [the latest Unit Commitment \(UC\)](#) execution
 - Invoke DC [Security analysis](#) [Analysis \(SA\)](#)
 - Invoke [unit-commitment UC](#):
- ***DC Security analysis (SA)*** – evaluates the impact of a set of given contingencies on the feasibility of the generation schedule
- ***Unit commitment (UC)*** – calculates the minimum bid [price-cost](#) schedule of the generating resources and biddable loads, subject to constraints. The components of cost include generation, startup, regulation, and reserve which are obtained from the Bid/Post system. Generation cost includes the effect of transmission loss factors. The set of constraints include:
 - Generation requirement
 - Reserve requirement
 - Generator operating limits
 - Generator minimum startup and down times
 - Maximum unit shutdowns per day
 - Transmission constraints
 - Transaction schedules.

If the hourly constraints on system generation requirement, reserve, or transmission do not allow a feasible solution, then UC continues to completion and reports the source of the infeasibility.

Each UC solution is comprised of an Ideal Dispatch and a Physical Dispatch. The Ideal Dispatch allows for GTs to be dispatched across their entire operating range and, therefore, is eligible to set price across their entire operating range. The LBMPs are determined from this dispatch. The Physical Dispatch uses blocked bid limits for GTs modeling the physical manner in which GTs operate. The generation schedules are determined from this dispatch.

The following modeling features are incorporated within NCUC:

- **Preventive Control Mode** – The generation schedule is determined such that no security violations will occur if any defined contingency occurs.
- **Generator Voltage Control** – Generators that are committed are modeled to regulate voltages within their reactive power capabilities.
- **System Voltage Stability** – System voltage stability is handled by imposing flow constraints on selected branch interfaces, representing the sum of the megawatt flows across the interface.
- **Infeasibility Handling** – When a network security constraint is detected as infeasible (unable to remove the violation) during the NCUC solution process, the constraint is relaxed, and solved for, it automatically ceases to be enforced in a hard manner and is permitted to be violated, subject to a penalty cost. Physical generating unit constraints, in contrast, are always enforced.

3.3.34.3.3 SCUC Inputs

Production Bid

A production bid is the composite of the incremental energy, minimum generation, bid operating costs, startup ~~costs~~ and reserve costs as follows:

- **Operating Bid** – The incremental operating energy bid for a generator is modeled as a piecewise linear monotonically increasing cost curves series of monotonically increasing constant cost steps. These bids are comprised of up to ~~20-12~~ segments. The first segment is determined by the minimum generation cost and defined by the no-load cost axis intercept (\$/hr) and a slope (\$/MWh). The ~~11 next~~ incremental energy segments are defined by MW break point and slope (\$/MWh) pairs. Different curves can be input for different schedule days.
- **Startup Bid** – The startup bid is given by piecewise linear curve of bid versus time the generator has been down-off line prior to the start. Different values can be input for different schedule days.
- **Reserve Bid** – The regulation cost bid (\$/MW) is input for all units that can contribute to regulation, is given by a regulation available capacity (MW), and a regulation capacity cost (\$/MW) and regulation movement cost (\$/MW). The cost of reserve from For off-line and non-dispatchable generators, the reserve bid is given by the following: a reserve availability cost (\$/MW).

Reserve availability cost (\$/hr)

Reserve amount cost (\$/MW).

Different costs apply to different reserve types and to reserves from off-line and non-dispatchable generators.

Startup and Shutdown Constraints

Multiple Shutdown limits constrain the number of times a generator can shut down in defined 24-hour periods. The time of day for the start of these periods is input. Shutdowns that occur at times when a generator becomes unavailable ~~do~~are not counteded towards the multiple shutdown limit constraint. Allowed values for this limit are 0 to 9.

Delivery Factors

The SCUC application uses the Security Analysis (SA) module to generate delivery factors for each time step in the commitment period. The delivery factors for each time step reflects the network topology expected for that time period and the generation dispatch from the Unit Commitment (UC) module.

Losses

Power losses occur in the transmission system as energy flows from generation sources to the loads. These losses appear as additional electrical load, requiring the generators to produce additional power to supply the losses. The SCUC, RTC and RTD each employ the same treatment of physical transmission losses. Transmission losses are calculated as part of the power flow solution for each time interval simulated by these programs for each of the eleven load zones in the NYCA.

The load forecast for day-ahead and real-time is determined for demand only and the calculation of losses within SCUC, RTC, and RTD is added to the forecast for total scheduling or dispatching requirements. The day-ahead load forecast plus the losses determined within SCUC are used to determine day-ahead supply resource requirements. Calculating losses for day-ahead involves the following steps:

1. The day-ahead load forecast estimates eleven zonal loads for each hour of the next day. The forecast does not include an estimate of zonal transmission losses.
2. Hourly losses for the load zones are calculated within the bid load pass of SCUC.
3. Energy is scheduled in the bid load pass of SCUC to meet (i) the hourly zonal bid load demands and (ii) the calculated hourly zonal losses for bid load demand.
4. Hourly losses for the load zones are also calculated within the forecast load pass of SCUC.
5. Energy is scheduled in the forecast load pass of SCUC to meet (i) the hourly day-ahead forecast of the eleven zonal loads and (ii) the calculated hourly zonal losses for forecast load demand.

Reserve Profile

Four reserves are modeled:

- Regulation capacity
- 10-minute spinning reserve

- 10-minute reserve (includes 10-minute spinning reserve)
- Operating reserve (includes 10-minute reserve and 30-minute reserve)

Only on-line generators can contribute to regulation and spinning reserve. Regulation capacity available is limited by the regulation capacity response rate, and spinning reserve are-is determined by the 5-and 10-minute generator response rates s-respectively. Both on-line and off-line available generators can contribute to 10-minute and 30-minute reserve.

~~Different reserve models apply to non-dispatchable (generators which are required to be on at a fixed MW output level) and dispatchable generators.~~ The contribution to Regulation from all generators and the contribution from non-dispatchable and off-line generators depend on their associated input reserve cost bids.

4.3.4 Demand Curves

The unit commitment and dispatch module used in both the SCUC and RTS systems utilizes demand curves to reflect scarcity. The demand curve allows the program to relax the applicable requirement if the shadow cost needed to supply the requirement exceeds a preset value. The demand curve functionality is used for the reserve and regulation requirements and to address transmission constraints. The following demand curves are implemented:

<u>Type</u>	<u>NY Region</u>	<u>Demand Curve Amount (MW)</u>	<u>Demand Curve Price (\$)</u>
<u>Regulation</u>	<u>NYCA</u>	<u>25.0</u>	<u>\$80.00</u>
		<u>80.0</u>	<u>\$180.00</u>
		<u>remainder</u>	<u>\$400.00</u>
<u>Spinning Reserve</u>	<u>NYCA</u>	<u>All</u>	<u>\$500.00</u>
<u>10 Minute Reserve</u>	<u>NYCA</u>	<u>All</u>	<u>\$450.00</u>
<u>30 Minute Reserve</u>	<u>NYCA</u>	<u>200.0</u>	<u>\$50.00</u>
		<u>400.0</u>	<u>\$100.00</u>
		<u>remainder</u>	<u>\$200.00</u>
<u>Spinning Reserve</u>	<u>Eastern NY</u>	<u>All</u>	<u>\$25.00</u>
<u>10 Minute Reserve</u>	<u>Eastern NY</u>	<u>All</u>	<u>\$500.00</u>
<u>30 Minute Reserve</u>	<u>Eastern NY</u>	<u>All</u>	<u>\$25.00</u>
<u>Spinning Reserve</u>	<u>Long Island</u>	<u>All</u>	<u>\$25.00</u>
<u>10 Minute Reserve</u>	<u>Long Island</u>	<u>All</u>	<u>\$25.00</u>
<u>30 Minute Reserve</u>	<u>Long Island</u>	<u>All</u>	<u>\$25.00</u>
<u>Transmission</u>	<u>All</u>	<u>All</u>	<u>\$4000.00</u>

3.3.4.3.5 Constraint Breaking

If the hourly resource constraints (i.e., system generation requirement, reserve, and transmission) specified for a given unit commitment run do not allow a feasible solution, the program relaxesbreaks the constraints in the following order:

- 1) Regulation and reserve constraints ~~Interruptible transactions~~
- 2) Transmission constraints ~~Export constraints~~

- ~~3) Import constraints~~
- ~~4) Interchange ramp~~ Reserve constraints
- ~~5) System Demand~~ generation requirement

To achieve a solution, the above constraints are relaxed incrementally in the given order until a solution can be found. All infeasibilities are reported.

In addition, the generator constraints (i.e., input availability, minimum up and down time constraints, multiple shut down limit constraints, and ramp constraints) may preclude a feasible solution. If possible, the program relaxes these constraints in the following order:

- 1) Low operating limit
- 2) Multiple shutdown limit

In the event that SCUC is unable to satisfy its security constraints, the NYISO must apply remedial actions, such as:

- ~~Soliciting additional bids~~ Dispatching generators to emergency upper operating limits
- ~~Requesting the C-~~ancellation or rescheduling of outages.

~~3.3.54.3.6~~ SCUC Interfaces with Other Systems

- *Bid/Post System* – The SCUC function retrieves Bid data ~~and loss factors~~ from the Bid/Post System function. Later SCUC provides the Bid/Post System with accepted generator, transaction, and load bids, clearing prices, etc. This information is also passed on to the Real-Time Commitment process during the Dispatch Day.
- ~~Performance Tracking System~~ – The SCUC retrieves unit status data (unit's last start or stop time and date; actual last status change augmented by predicted status change).
- ~~Outage~~ Energy Management System (EMS) Scheduler – The SCUC function retrieves equipment outages, reserve and regulation requirements, unit status history and contingency definition information from the ~~OS-EMS~~ function.
- ~~Post Unit Commitment~~ Load Forecaster – The SCUC function ~~provides~~ receives the load forecast for the ~~the PUC function with the input and output data associated with the Day-Ahead Scheduling study period from the Load Forecasting program.~~

~~3.44.4~~ Bilateral Transaction Evaluations

Refer to the *NYISO Transmission & Dispatching Operations Manual* for a more complete description of Bilateral Transaction Scheduling and Curtailment.

~~3.4.14.4.1~~ Firm Bilateral Transactions

Internal firm ~~B~~ bilateral transactions are tabulated and automatically approved. Based upon verification with other control areas, external ~~firm~~

bilateral transactions are either approved or rejected. The results for all ~~firm~~ transactions are posted on the Bid/Post System.

4.4.2 Multi-Hour Block Transactions (MHBT)

Multi-hour block transactions are evaluated in the Day-Ahead Market relative to alternative offers and scheduled or not scheduled based upon the total production cost associated with the offer over the day. Instances may arise where a multi-hour block transaction may appear to be economic, as compared to posted Locational Based Marginal Prices (LBMPs), but was not scheduled.

The following examples describe possible scenarios where a submitted multi-hour block transaction offer was not scheduled even though it may appear to be economic as compared to the posted LBMPs:

Example 1 - The submitted MHBT offer is less than the posted LBMP for an hour or certain hours (but not all hours) of the offer, but was not scheduled. In this case, although the MHBT offer was less than the posted LBMP during some hours, the total cost of the bid transaction, over the hours bid, was greater than the alternative offers selected for those hours. Market rules for MHBTs do not allow for the selective scheduling of an hour or hours if less than the bid-specified minimum run time.

Example 2 - The submitted MHBT offer is less than the posted LBMP for all hours of the offer, but the offer was not scheduled. In this case, the MHBT offer was not selected because the offer would have resulted in even higher LBMPs than the LBMPs that were posted for some or all of the hours considered. One possible reason for this condition is that the scheduling of the MHBT in question may have precluded the scheduling of an alternative offer(s) due to minimum generation or minimum run time constraints related to the alternative offer(s). This situation would then result in a different set of resources being scheduled with an even higher priced offer setting the LBMP.

Another possibility is that the submitted MHBT was the marginal offer. In this case, scheduling of the MHBT may have exceeded the energy scheduling requirements for an hour or several hours. Since the market rules for MHBTs require that an MHBT be scheduled for the full bid MW amount for at least the minimum run time specified, alternative offers are scheduled to arrive at the most economic schedule that best meets the commitment requirements of each hour.

Scheduling decisions made for hours outside of the hours covered in a MHBT offer may also impact the scheduling of MHBTs. Even though a MHBT may be economic for the hours bid, scheduling the MHBT in question for those hours may result in additional costs related to resources and transactions scheduled for hours outside of the hours covered by the MHBT bid, yielding higher overall costs for the day.

LBMP calculations require consideration of numerous inter-related factors, not the least of which is system security. As a result, SCUC's decision to schedule, or not, certain MHBT offers is based on factors that may not be readily apparent from posted LBMPs.

3.4.24.4.3 **Non-Firm Bilateral Transactions**

Non-firm transactions are those Bilateral Transactions that are not willing to pay congestion charges. These transactions are treated as follows in the Day-Ahead scheduling process:

An evaluation of non-firm external transactions occurs after the ~~Day-Ahead Market (DAM)~~DAM and Real-Time Market have closed. The results of these evaluations are strictly advisory, until the NYISO system operator has confirmed the transactions.

The evaluation of non-firm transactions is based on which NERC product level (one to six) the transaction is, its bid time stamp (first in, first evaluated), the associated Congestion costs, and the system's Available Transfer CapabilityATCs. Additionally, external non-firm transactions are subject to the maximum hourly change in the NYISO interchange and must be confirmed with the neighboring control areas.

Non-Firm Bilateral Transaction Bid Submission and Selection Process

- 1) Non-firm transactions are submitted prior to the DAM close.
- 2) The DAM closes.
- 3) The ~~Security Constrained Unit Commitment (SCUC)~~SCUC program is run, without considering non-firm transactions.
- 4) The non-firm transaction selector program is run using SCUC congestion data.
- 5) A bid status of "Advisory Accepted" or "Advisory Rejected" is assigned to each non-firm transaction.
- 6) The DAM schedules and non-firm advisory schedules are posted.
- 7) Non-firm transactions are bid into the Real-Time Market prior to its close. All valid DAM non-firm transactions for the real-time hour being evaluated are re-evaluated, regardless of their status from the DAM evaluation.
- 8) The Real-Time Market closes.
- 9) The Real-Time Commitment (RTC) is run, without considering non-firm transactions.
- 10) The non-firm transaction selector program is run using RTC congestion data.
- 11) A bid status of "Advisory Accepted", "Bid Accepted", or "Bid Rejected" is assigned to each non-firm transaction.
- 12) The Real-Time schedules and non-firm advisory schedules are posted.
- 13) The external "Advisory Accepted" are sent to the IS+ interchange scheduler for scheduling and confirmation with neighboring control areas.
- 14) Confirmed internal non-firm transactions will be posted to the Market Information System (MIS) with "Bid Accepted" status.

NYISO DAY-AHEAD SCHEDULING MANUAL

- 15) As schedules are agreed upon with neighboring control areas, the external non-firm transactions will be updated to the agreed upon level, and transaction status will be posted to the MIS as “Bid Accepted”.
- 16) Non-Firm transmission will be curtailed in real time when congestion occurs and agreement with neighboring control areas is reached.

Table 4-2: Non-Firm Transaction Selector Program Logic

<u>Non-Firm Transaction Condition</u>	<u>Posting</u>
<u>Congestion is negative and ATC is available</u>	<u>Advisory Accepted</u>
<u>Congestion is negative and ATC is partly available</u>	<u>Advisory Accepted*</u>
<u>Congestion is zero and ATC is available</u>	<u>Advisory Accepted</u>
<u>Congestion is zero and ATC is partly available</u>	<u>Advisory Accepted*</u>
<u>Congestion is zero and ATC is not available</u>	<u>Advisory Rejected</u>
<u>Non-firm transaction’s congestion is positive</u>	<u>Advisory Rejected</u>

* Transactions are ranked by NERC product type and then by time stamp. The partly available transaction is prorated to remaining ATC.

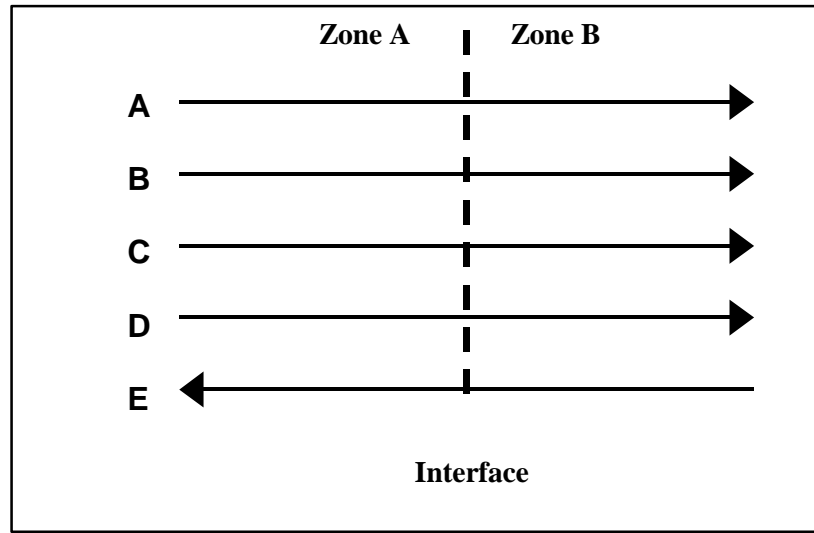

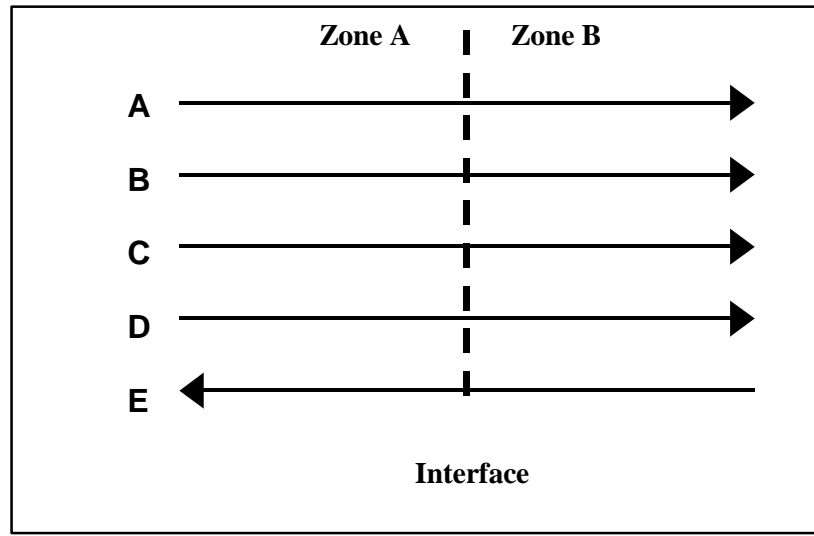

Figure 4-3: Transaction Example

Assumptions

- The ATC of the interface is 50 MW in both directions.
- Non-firm transactions A, B, C, D, & E are internal bilateral transactions.
- The Congestion Component of the LBMP is equal in both zones, implying a zero congestion cost.

Table 4-4: Transaction Parameters

<u>Transaction</u>	<u>Bid (MW)</u>	<u>Time Stamp Priority</u>	<u>After DAM/RTC Evaluation</u>	<u>After System Operator Confirmation</u>	<u>Scheduled (MW)</u>
<u>A</u>	<u>25</u>	<u>1</u>	<u>AA</u>	<u>BA</u>	<u>25</u>
<u>B</u>	<u>20</u>	<u>2</u>	<u>AA</u>	<u>BA</u>	<u>20</u>
<u>C</u>	<u>15</u>	<u>3</u>	<u>AA</u>	<u>BA</u>	<u>5</u>
<u>D</u>	<u>10</u>	<u>4</u>	<u>AR</u>	<u>BR</u>	<u>0</u>
<u>E</u>	<u>10</u>	<u>5</u>	<u>AA</u>	<u>BA</u>	<u>10*</u>

* Counter flow transaction (E) does not increase ATC.
 AA = Advisory Accepted
 AR = Advisory Rejected
 BA = Bid Accepted
 BR = Bid Rejected

4.5. DAY-AHEAD INTERFACE TO THE DISPATCH DAY

This section describes the primary interfaces between the Day-Ahead activities and the Dispatch Day activities.

4.15.1 Interchange Schedule Interface

The Interchange Schedule (IS+) function provides the primary mechanism for entering, modifying, or deleting interchange transactions for the Day-Ahead and Real-Time markets. ~~IS+ displays and reports are implemented using Oracle.~~

Data Model

The fundamental data objects within IS+ are the:

- Customer
- Contract
- Transaction
- Transaction segment
- Transaction class
- Customer contact
- NERC tag

Refer to the [*NYISO Transmission Services Manual*](#) for additional information.

4.1.15.1.1 User Interface

The IS+ function provides video displays to enter and review data. ~~These displays are implemented on workstations in Oracle.~~

Summary displays show transaction information filtered according to ~~either~~ user-enterable or pre-specified filtering and ordering parameters, such as:

- Transaction chronology
- Transaction attributes
- Currently active transactions

4.1.25.1.2 Functional Interfaces

The Interchange Scheduler subsystem has interfaces with the following functions:

Automatic Generation Control

The AGC function obtains the net scheduled interchange value (DNI) for the NY Control Area from IS+.

Historical Information Retention

All relevant information from IS+ is archived.

Real-Time Market Evaluation

The ~~IS+ function passes~~ accepted Day-Ahead transaction ~~bids schedules along with available Real-Time transaction bids are passed~~ to the ~~Real-Time Commitment (RTC)~~RTC function through the Bid/Post System. The RTC function passes accepted ~~operating-D~~day transaction schedules to the IS+ function through the Bid/Post System. The final Desired Net Interchanges for the NYCA and neighboring Control Areas are passed from the IS+ function to the Real-Time Dispatch (RTD) function through the Bid/Post System.

4.25.2 Generation Schedule Interface

The ~~Post Security Constrained Unit Commitment~~SCUC function (see Section 4.3.65) passes accepted generation schedules from the Day-Ahead process to the Bid/Post System, which then passes the information on to the Real-Time Commitment (RTC) process during the Dispatch Day.

4.35.3 Ancillary Service Schedule Interface

The ~~Security Constrained Post Unit Commitment~~SCUC function (see Section 3.5) passes the following accepted Ancillary Services ~~(AS)~~schedules from the Day-Ahead process to the Bid/Post System, ~~which then passes the information on to the Real-Time Commitment (RTC) process during the Dispatch Day.~~

- Regulation
- Spinning Reserve
- Non-spinning Reserve

The Ancillary Services AS are evaluated again as part of the Real-Time Scheduling systems solutions and the accepted AS Ancillary Service schedules are passed to the Bid/Post System.

~~5. TRANSMISSION CONSTRAINT GROUP ASSEMBLY~~

~~5.1 TCG Definition~~

~~The TCG file contains limits on the amount of energy that can be imported and exported for each transmission constraint group. The following data defines the constraints:~~

~~Generators and loads associated with each constraint group.~~

~~For each transmission constraint group the following is entered:~~

- ~~a. Load (MW) and transmission limit (MW) for each time increment~~
- ~~b. Limit type: minimum, maximum, or equality~~
- ~~c. Reserve and regulation requirements.~~

~~5.2 TCG User Interface~~

~~These procedures are performed by the NYISO Operations Planning personnel prior to the daily unit commitment run, after the Day Ahead Bid Closing. The procedures are executed from network connected workstations.~~

~~5.3 TCG Data Assembly~~

~~The NYISO performs the following actions:~~

~~Collects data from the following sources:~~

- ~~d. Unit location organized by constraint group~~
- ~~e. Reserve & Regulation Requirements~~
- ~~f. NYISO preliminary zonal Load Forecast~~
- ~~g. Validated LSE Load Bids from the Bid/Post System~~
- ~~h. LSE Load Forecasts by zone from the Bid/Post System~~
- ~~i. Total Transfer Capabilities (updated to reflect transmission outages)~~
- ~~j. Firm transaction exports.~~

~~Assigns Generators to Zones~~

~~Determines the zonal load forecast:~~

~~The state wide load forecast used in SCUC is based on a summation of the zonal load values. The NYISO Services tariff requires that the LSE load forecasts be considered in the development of the state wide forecast when it is consistent with the NYISO forecast. The LSE zonal load forecast is considered to be consistent with the NYISO forecast when the sum of the LSE zonal load forecasts on a control area basis is less than 105% of the NYISO forecast on a state wide basis and when the LSE forecast is within 100% to 105% of the NYISO forecast on a zonal basis.~~

~~Therefore, if the sum of the LSE zonal load forecasts is not consistent with the NYISO state wide forecast, then the LSE zonal load forecasts are not considered. Additionally, if a LSE zonal load forecast is not consistent with the NYISO zonal forecast, then the LSE~~

~~zonal load forecast is not considered. Therefore, the zonal load values used in SCUC are determined using the following rules:~~

~~k. The Bid Load plus Bilateral contracts zonal value is used as the zonal load value when:~~

- ~~➤ The Bid Load plus bilateral contracts zonal value is greater than the NYISO zonal load forecast and,~~
- ~~➤ The Bid Load plus bilateral contracts zonal value is greater than the LSE zonal load forecast, when determined to be consistent with the NYISO forecast.~~

~~l. The NYISO zonal load forecast is used as the zonal load value when:~~

- ~~➤ The NYISO zonal load forecast is greater than the Bid Load plus Bilateral contracts zonal load value and,~~
- ~~➤ The NYISO zonal load forecast is greater than the LSE zonal load forecast, when determined to be consistent with the NYISO forecast.~~

~~m. The LSE zonal load forecast, when determined to be consistent with the NYISO forecast, is used as the zonal load value when:~~

- ~~➤ The LSE zonal load forecast is greater than the NYISO zonal load forecast and,~~
- ~~➤ The LSE zonal load forecast is greater than the Bid Load plus bilateral contracts zonal value.~~

~~Posts the resultant zonal load forecast (from Item 3 above) on the Bid/Post System
Formats the data for the TCG files:~~

- ~~n. File with LSE load bids~~
- ~~o. File with total NYISO load forecast.~~

6. NYISO LOAD FORECAST PROCESS

This section describes the NYISO Load Forecast process, ~~functions and functional~~ and user interfaces.

6.1 Load Forecast Overview

The Load Forecast function is used to forecast hourly loads for each of the ~~elev~~ NY Control Area Zones ~~and at the statewide level~~. ~~The Load Forecast function uses a combination of a~~Advanced nNeural Nnetwork and RRegression type forecast models to generate its forecasts. The function uses historical load and weather data information ~~(including temperature, dew point, cloud cover and wind speed)~~ for each Zone to develop Zone load forecast models. These models are then used together with Zone weather forecasts to develop a Zone load forecast. The function develops ~~the individual Zone~~ hourly load forecasts for the current day and the next six days, ~~a total of up to 168 hours~~. ~~The total system load is calculated as the sum of the loads for all zones.~~

6.2 Load Forecast Functions

The load forecast functional description covers the following:

- Load Forecast Module
- ~~Study Load Forecast Module~~
- Load Forecast Training Module
- Load Forecast Functional Interfaces

6.2.1 Load Forecast Module

~~A single Load Forecast Module is used to produce the load forecasts for all the scheduling systems. The program automatically generates the 5 minute forecasts used by RTS. The hourly forecasts required for SCUC are published This module is executed on demand to forecast the hourly load for the current day and up to six days for each Zone. The published forecast is posted to the NYISO website by 08:00 a.m. AM a.m. every day, or as soon thereafter as is reasonably possible. The module uses the recent historical data, the current day historical data (up to the first hour of forecast), the weather forecast data for the forecast period, and the most recently updated load forecast models. The forecasts that are produced for the scheduling systems represent only the expected demand usage and do not include transmission losses. The transmission losses are specifically computed as part of the scheduling systems' functionality. The module allows for defining a season for each day of the forecast. Upon such definition, the module selects the corresponding forecast model parameters for each day of the forecast.~~

~~The Load Forecast module provides the following capabilities:~~

- ~~Update of Historical Data~~—When the 24 values of the actual load is available, they can be appended to the historical data on demand.

- ~~*Daily Error Analysis*~~—An error analysis is performed for the day before the current day. The actual load values are compared with the model forecast of the load using the actual weather data (after the fact).
- ~~*Rolling Storage of Load Forecast*~~—A rolling storage of the load forecast is kept to compare against the actual load values.
- ~~*Data Set Manager*~~—The Load Forecast function is capable of saving the current working dataset into a saved dataset for each Zone. Up to five datasets are allowed for each Zone. The retrieval of the saved datasets into the current working dataset is allowed. Each dataset includes the model parameters, and other data files used by various models.

~~6.2.2 Study Load Forecast Module~~

~~This module generates hourly load forecast values for a seven-day period in the past. The period of study should be within the available historical data. Similar to the Load Forecast module, this module allows for defining a season for each day of the forecast. Upon such definition, the module selects the corresponding forecast model parameters for each day of the forecast. Since the actual load value is known, an error calculation is performed to compute the difference between the actual load and the forecasted load obtained using the actual weather data. This mode of operation is used to verify proper operation of the model.~~

~~6.2.36.2.2~~ **Load Forecast Training Module**

This module allows the generation of ~~neural network based~~ load forecasts models for each Zone ~~and for the New York Control Area~~. There is one load forecast model for each day of the week and each weather-defined season. Up to four seasons are allowed. The module allows for selection of model input parameters and parameters of neural network training.

The training module requires up to four years of historical hourly load and weather data for each area. The module allows for defining weather-defined season boundaries within the historical data, which is based on the load shape changes from one season to another. The module allows a complete or partial selection of historical data for training of a load forecast model. The training of the models for all areas (for all day types and all defined seasons) is automated through execution of a designated macro in the program.

~~6.2.46.2.3~~ **Load Forecast Functional Interfaces**

This section outlines the functional interchange of data between Load Forecast (LF) and other NYISO applications.

Bid/PostOracle Information Storage and Retrieval (OISR) System

The LF function provides the Bid/PostOISR System function with the NYCA and Zone hourly loads for storage. The BSYSMIS, SCUC and RTS systems can then retrieve the most up to date load forecast available.

Historical Information Retention

Load forecast results are archived.

Historical Load Data File

The LF function retrieves historical load ~~and weather~~ data from ~~the historical data file maintained from actual data retrieved from the on-line~~ the EMS ~~through its PI Historian data.~~

Weather Forecast File Data

The LF function retrieves weather forecast ~~data and historical weather~~ data from ~~the weather forecast data files maintained from data~~ received from the weather service.

6.3 Load Forecast User Interface

The NYISO forecast is on a zonal basis and is produced by NYISO ~~Energy Market Operations~~ Planning personnel. Initial forecasting is completed ~~by 6:00 AM a.m. prior to initializing SCUC~~ each day prior to the Dispatch Day. The forecast is for the Dispatch Day and the next six days, a total of up to 168 hours.

The Load Forecast function provides a complete set of input/output displays for a typical load zone, ~~considered to be a working environment.~~ Input/output displays are available at the system level to present the load forecast values.

The function is accompanied with a set of displays for input, execution, and output. The required files as input to the program ~~as well as output of the program~~ are in ASCII .csv format, ~~which can be generated from other database tables for the input files, and be ported to other database tables for the output files.~~

The function provides the capability to ~~export-publish the~~ load forecast ~~data to file in the OISR format required for the multi-area~~ Security Constrained Unit Commitment SCUC package to utilize. ~~The exported areas can be specified to be either individual forecast areas or super-zones.~~

By 08:00 a.m. AM a.m., or as soon thereafter as is reasonably possible, the NYISO develops and posts its statewide Load forecast on the OASIS.

MIS Load Modeling and LSE Responsibilities

The NYISO will model loads in the Market Information System (MIS) for Load Serving Entities (LSE) and the LSEs must accurately forecast, bid, and schedule their loads to reflect their customers.

Each NYISO Customer that has load must inform the NYISO of the load and the load will be modeled in the MIS with a unique ID, a link to an LSE, and a link to one of the NYISO sub-zones. These loads must be modeled 30 days in advance of taking service under the NYISO tariffs.

Each LSE has one associated Billing Organization. Bills and invoices are calculated for each Billing Organization and include the settlements for the associated LSE(s) and load(s). If a retail access load customer changes from one LSE to another LSE then it is the

responsibility of the LSEs to coordinate the change with themselves and the Transmission Owner (TO) so that each LSE forecasts, bids, and schedules the changed load accurately.

Within each sub-zone, the Transmission Owner (TO) must certify that the LSEs have met their requirements and can conduct business in that sub-zone. The NYISO will ask for verification that all LSEs, with their associated loads, that are modeled in the MIS are certified by the TO.

The load names specified in the NYISO MIS represent the customers that have a certain amount of load (one megawatt or greater— individual or aggregated). Individual retail customers, meters, or accounts are not tracked by the NYISO. The NYISO does not need to know if accounts or customers switch providers. The NYISO only needs to know which providers are certified. The TO and the LSE must coordinate activities when customers switch providers to ensure that the load is not missed or double counted.

Figure 7-1 helps explain how a load change may occur.

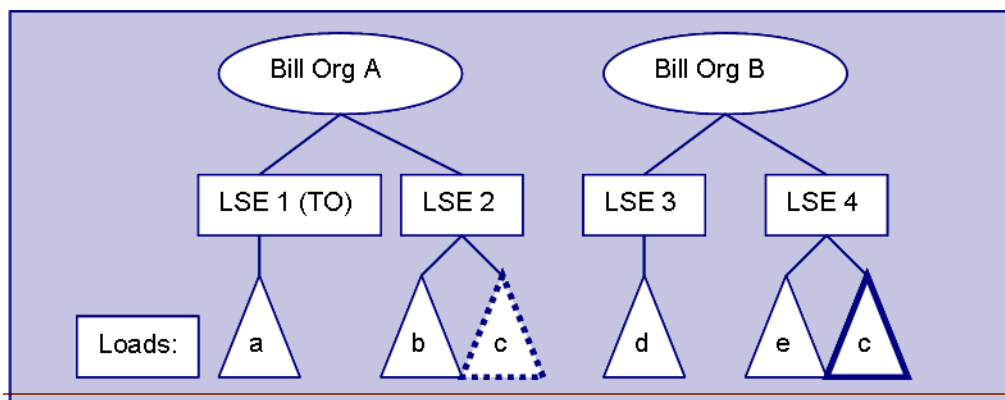

Figure 6-1: Load Modeling

If load c switches to LSE 4 then: _____

- _____ LSE 2 & 4 coordinate with the TO-LSE 1
- _____ Billing Org B receives Load c settlement
- _____ LSE 4 now forecasts, bids, or schedules Load c
- _____ LSE 2 does not forecast, bid, or schedule Load c

The NYISO only needs to know that LSE 2 & 4 are certified by the TO. If only a partial load is switched then only that amount is coordinated between parties. If load is incorrectly bid or scheduled then, after actual metering is determined, the billing will be adjusted for loads that are off schedule (see Section 7.5).

Load Forecasts for Facilities in the Market Information System

In the DAM, a load forecast for each LSE's load should equal the sum of the Bilateral Transactions scheduled to the load, the load's fixed MW bid, the loads' Price Capped Loads, and the expected Real-Time Market energy required to serve the remaining load. Hourly Load Forecasts submitted in the DAM can be revised any time up to when billing calculation are performed.

Load Forecast

The load forecast predicts the level of Load at a point of withdrawal for each hour. In the SCUC program, the load forecast for all the loads within a zone are summed to determine a zonal forecast, which, if deemed credible, would be used in determining a unit commitment schedule. These load forecasts are also used to allocate the metered zonal load among the LSEs for billing calculations. Since the forecasts are used in billing calculations, they can be revised after the real-time dispatch to better approximate meter measurements up to noon the next day when the billing programs are run. Final billing adjustments will be made months later after final meter reading has been reported.

If your organization has utilized two loads to schedule energy for your total sub-zonal load but have submitted the load forecast for both loads in only one of the loads then the energy proportioned to each load will not coincide with your Fixed Bids and Bilaterals.

If you have scheduled a bilateral into a load without submitting the corresponding forecast then the billing program would assume that the load is off schedule and the bilateral energy is sold back into the LBMP market. If you submit a forecast that includes the load to be served via the Bilateral of another load your bill will show purchases off the LBMP market. The daily bill then accounts for these actions and the adjustments to correct the bill will not be made until actual metered values are received two months later.

Billing Adjustments

In order to prevent the need for billing adjustments, Hourly Load Forecasts submitted in the DAM can be revised up until 12:00 p.m. (Daily bills start from 1:00 p.m. on the day after the dispatch day) of the day following the effective date of the forecast. The MW total of the revised Load Forecasts for the LSEs comprising the sub-zone must equal the gross for the sub-zone.

For further information on forecasts and metering adjustments, please review the August 20, 1998 White Paper by the ISO Retail Access Team on the Retail Access Settlement Process. This document can be found on Google: "Retail Access Settlement Process"

Example 1: — An organization's total sub-zonal load for an hour is 2000 MW. The organization is using one load/sink to schedule the energy needed to satisfy the total sub-zonal load.

- Organization has entered a load bid of 1500 MW in the DAM (Bid accepted in MIS)
- Organization has entered firm transaction #1 for 200 MW (Source confirms schedule & 200 MW scheduled in MIS)
- Organization has entered firm transaction #2 for 100 MW (Source confirms schedule & 100 MW scheduled in MIS)

Forecast 1: — 2000 MW

Result 1: — 1500 MW purchased in the Day Ahead LBMP Market

— 200 MW purchased in the Real Time Market

— 200 MW Purchased in bilateral market with transaction #1

100 MW Purchased in bilateral market with transaction #2
Total 1: 2000 MW

Example 2 & 3: An organization's total sub-zonal load for an hour is 2000 MW. The organization is using three loads/sinks to schedule the energy needed to satisfy the total sub-zonal load.

- Load/sink #1 has bid 1500 MW in the DAM (Bid accepted in MIS)
- Load/sink #2 has an auto-confirm firm transaction for 200 MW (200 MW scheduled)
- Load/sink #3 has an auto-confirm firm transaction for 100 MW (100 MW scheduled)

Forecast 2: Load/sink #1 enters a forecast load of 1700 MW
Load/sink #2 enters a forecast load of 200 MW
Load/sink #3 enters a forecast load of 100 MW

Result 2: Load/sink #1 1500 MW purchased in the Day Ahead LBMP Market
200 MW purchased in the Real-Time Market (RTM)
Load/sink #2 200 MW received through firm transaction
0 MW is purchased/sold in the RTM
Load/sink #3 100 MW received through firm transaction
0 MW is purchased/sold in the RTM

Total 2: 2000 MW

Forecast 3: Load/sink #1 enters a forecast load of 2000 MW
Load/sink #2 doesn't enter a forecast load
Load/sink #3 doesn't enter a forecast load

Result 3: Load/sink #1 1500 MW purchased in the Day Ahead LBMP Market
500 MW purchased in the RTM
Load/sink #2 200 MW received through firm transaction
LSE considered "Off-Schedule," 200 MW sold into RTM
Load/sink #3 100 MW received through firm transaction
LSE considered "Off-Schedule," 100 MW sold into RTM

Total 3: 2000 MW

7. SCUC EXECUTION

This section describes ~~Security Constrained Unit Commitment~~SCUC Execution procedure.

7.1 SCUC

These procedures are performed by the NYISO Energy Market Operations Planning personnel after the ~~pre-UCBSYS~~MIS DAM Market closing process has completed. The procedures are executed on the ~~S.P.I.D.E.R. workstation~~RANGER system.

7.2 SCUC Execution Actions

The NYISO Energy Market Operations Planning personnel perform the following actions:

- 1) Retrieve the ~~Bid/Post~~MIS System file for the next day's Bids
- 2) ~~Acquire current Security Constrained Unit Commitment history~~Transfer data from the EMS / Real Time server
- 3) ~~Retrieve-Perform~~ the ~~TCG-SRE end of the day fill in process~~file
Review and select SCUC run time options
- 4) Execute the SCUC.
- 5) Review and analyze results
Assemble output SCUC file
- 6) Send the SCUC output ~~file data~~ to the Bid/Post System Box
Send SCUC information to the Historical Information System
- 7) Save SCUC case for:
 - a. Archival purposes
 - b. Next SCUC History run
 - c. Dispute resolution purposes

8. RELIABILITY FORECAST

This section describes the maintenance of reliability in the time frame one to seven days ahead of the Dispatch Day.

8.1 Reliability Forecast Requirements

In the SCUC program, system operation shall be optimized based on Bids over the Dispatch Day. However, to preserve system reliability, the NYISO must ensure that there will be sufficient resources available to meet forecasted Load and reserve requirements over the seven-day period that begins with the next Dispatch Day.

The NYISO will perform a Supplemental Resource Evaluation (SRE) for days two through seven of the commitment cycle. If it is determined that a long start-up time Generator is needed for reliability, the NYISO shall accept a Bid from the Generator and the Generator will begin its start-up sequence. During each day of the start-up sequence, the NYISO will perform a SRE to determine if long start-up time Generators will still be needed as previously forecasted. If the Generator is still needed, it will continue to accrue start-up cost payments on a linear basis. If at any time it is determined that the Generator will not be needed as previously forecasted, the NYISO shall order the Generator to abort its start-up sequence, and its start-up payment entitlement will cease at that point.

The NYISO will commit ~~to~~ long start-up time Generators to preserve reliability. However, the NYISO will not commit resources with long start-up times to reduce the cost of meeting Loads that it expects to occur in days following the next Dispatch Day. Supplemental payments to these Generators, if necessary, will be determined according to the provisions of Attachment C of the NYISO Services Tariff, and will be recovered by the NYISO under Rate Schedule 1 of the NYISO OATT.

NYISO Actions

The NYISO shall perform the SRE as follows:

- 1) The NYISO shall develop a forecast of daily system peak Load for days two through seven in this seven-day period (~~using LSE forecast data, where appropriate~~) and add the appropriate reserve margin.
- 2) The NYISO shall then forecast its available Generators for the day in question by summing the Operating Capacity for all Generators currently in operation that are available for the commitment cycle, the Operating Capacity of all other Generators capable of starting on subsequent days to be available on the day in question, and an estimate of the net imports from External Bilateral Transactions.
- 3) If the forecasted peak Load plus reserves exceeds the NYISO's forecast of available Generators for the day in question, then the NYISO shall commit additional Generators capable of starting prior to the day in question (e.g., start-up period of two days when looking at day three) to assure system reliability.
- 4) In choosing among Generators with comparable start-up periods, the NYISO shall schedule Generators to minimize the start-up and minimum Generation Bid costs of meeting forecasted peak Load plus Ancillary Services consistent with the Reliability Rules.

- 5) In determining the appropriate reserve margin for days two through seven, the NYISO will supplement the normal reserve requirements to allow for forced outages of the short start-up period units (e.g., gas turbines) assumed to be operating at maximum output in the unit commitment analysis for reliability.

The bidding requirements and the Bid tables in Attachment D of the NYISO Services Tariff indicate that Energy Bids are to be provided for days one through seven. Energy Bids are binding for day one only for units in operation or with start-up periods less than one day. Minimum generation cost Bids for Generators with start-up periods greater than one day will be binding only for units that are committed by the NYISO and only for the first day in which those units could produce Energy given their start-up periods. For example, minimum generation cost Bids for a Generator with a start-up period of two days would be binding only for day three because, if that unit begins to start up at any time during day one, it would begin to produce Energy 48 hours later on day three. Similarly, the minimum generation cost Bids for a Generator with a start-up period of three days would be binding only for day four.

8.2 Reliability Responsibilities

NYISO Actions

To insure that the New York Control Area (NYCA) will meet its operating capability, reserve, interchange, and load requirements in a reliable manner, the NYISO Scheduling staff performs the following:

- 1) Determine that the NYCA NY Control Area has sufficient operating capability and reserve to meet the forecasted load and reserve requirements for the Day-Ahead period.

Determine that the NYCA NY Control Area has sufficient Regulation margin to meet light load requirements.

Coordinate, verify, and confirm the Day-Ahead transaction schedules.

Coordinate the scheduling of NYCA NY Control Area Inadvertent Interchange payback when conditions warrant.

Identify hours when the magnitude of External interchange schedule changes could degrade NYCA NY Control Area control performance and adjust transactions accordingly.

Market Participant Actions

The Market Participants must perform the following:

- 1) Notify the NYISO of any scheduled generation and transmission outages according to the procedures defined in the [NYISO Outage Scheduling Manual](#) that would affect transactions.

Respond to NYISO directions involving security, capability, schedule changes, and light load problems.

8.3 Dealing with Insufficient Bids

The following provides procedures to deal with insufficient bids and to ensure that sufficient operating capacity is available to serve all NYCA load. To do this, a variety of measures (i.e., installed capacity, annual reliability assessments, maintenance outage coordination, seven day reliability forecasts, ~~Security Constrained Day-Ahead Unit Commitment~~ (SCUC), etc.) will help reduce the likelihood of experiencing insufficient available bids. Notwithstanding, the NYISO needs the ability to identify potential bid insufficiencies with adequate lead-time to be able to solicit and re-evaluate additional bids.

The Need for Bids

The NYISO can-not ~~order on commit~~ resources in the DAM without receiving bids from those resources. ~~U~~ Upon determining that it needs more Day-Ahead resources the NYISO will issue a public request for more bids. This information will be posted prominently to the NYISO web page. If the NYISO continues to have insufficient bids to serve NYCA load even after bid solicitations, it can reasonably be assumed that sufficient resources are truly not available. In this case, the NYISO should implement emergency measures that may include purchasing external emergency energy, shared activation of reserves, and load curtailment.

Reliability Assessments

The NYISO will perform a reliability assessment to determine if projected Operating Reserves over an upcoming period will be adequate. This reliability assessment will compare projected Operating Capacity with the forecast NYCA Peak Load (where Operating Capacity equals NYCA Installed Capacity less Proposed Maintenance Outage Schedules less Projected Unavailable Capacity). For instance:

Table 8-1: Reliability Assessment - Load and Capacity Table

Assessment	MW Capacity
NYCA Installed Capacity (ICAP)	30,000 MW
Less Scheduled Maintenance Outages	(3,000 MW)
Less Forecast Unavailable	(4,000 MW)
Net Operating Capability	23,000 MW
Less Forecast NYCA Peak Load (including Firm Energy Exports)	(20,000 MW)
Net Operating Reserves	3,000 MW
Less Required Operating Reserves	(1,800 MW)
Operating Reserve Surplus (Deficiency)	1,200 MW

If Operating Capacity is expected to be deficient, the NYISO will take actions as specified below for various time frames.

8.4 Reliability Assessment Processes

The NYISO continually re-evaluates the reliability of the NYCA. There are several reliability assessments of any given Operating Day performed over various time horizons. The sequences of these evaluations are described next.

Annual Reliability

The NYISO has the responsibility to ensure sufficient capacity is expected to be available to serve all NYCA load on an annual basis. This is accomplished using the NYISO maintenance outage coordination procedure. All installed capacity providers are required to abide by NYISO maintenance coordination, and all other generating resources are required to inform the NYISO of their annual maintenance plans.

Based upon a weekly reliability assessment for the upcoming calendar year, if Operating Capacity is expected to be deficient in a certain period, the NYISO will take actions to modify generator maintenance schedules as outlined in the *[NYISO Outage Scheduling Manual](#)**[NYISO Outage Scheduling Manual](#)*.

7-Day Reliability

Similarly to the case of Annual Reliability, the NYISO will perform a reliability assessment on a rolling basis to determine if projected Operating Reserves for each day of the next seven days will be adequate. If a deficiency is forecast, the NYISO will commit generation capable of starting in time to meet the expected load. In addition, if resources are anticipated to be insufficient for any day of the rolling commitment week, the NYISO will immediately broadcast a bid solicitation message via the Market Information System (MIS) to all market participants, identifying all deficient bid times and categories.

Day-Ahead Reliability

At the close of the Day-Ahead market, the NYISO will use SCUC to evaluate bids and clear the Day-Ahead market. If SCUC cannot solve due to insufficient bids to meet Day-Ahead requirements, the NYISO shall commit all bid resources; and then solicit additional bids and initiate the Supplemental Resource Evaluation (SRE) process as described in Section 10 of ~~this manual~~*[this Manual](#)*. When the Day-Ahead Energy Market does not clear due to insufficient resources, the calculated Energy LBMP will be the marginal cost to supply the last MW of load; MW amounts in forward contracts for load bids will be prorated to match total supply forward contracts with load forward contracts.

Post SCUC Day-Ahead and Pre or Post RTC In-Day Reliability

Any time an event occurs such as a generator trip or a transmission outage that renders a Day-Ahead commitment insufficient for hours that would not yet be evaluated by Real-Time Commitment (RTC) (or in Real-Time after RTC has run), the NYISO **must** perform an SRE.

Real-Time Reliability

The NYISO will use Real-Time Commitment (RTC) to evaluate Real-Time bids, and check that sufficient bids exist for the next two subsequent hours. If RTC cannot solve due to insufficient bids to meet Real-Time requirements, the NYISO shall commit all bid resources [subject to network security constraints](#); and then solicit additional bids and initiate the SRE process.

9. INTERCHANGE COORDINATION PROCEDURE

Scheduled interchange must be coordinated between Control Areas to prevent:

- Frequency deviations
- Accumulation of Inadvertent Interchange
- Exceeding mutually established transfer limits

NYISO Actions

The NYISO schedules external bilateral transactions with other Control Areas in accordance with current NERC policies and procedures.

10. SUPPLEMENTAL RESOURCE EVALUATION ONE OR MORE DAYS AHEAD

The Supplemental Resource Evaluation (SRE) process is used to commit additional resources outside of the SCUC and RTC processes to meet NYISO reliability or local reliability requirements. The Transmission and Dispatch Manual provide more information on SREs in sections 5.7.5 through 5.7.12.

10.1—SRE Background and Overview

~~Commitment refers to the process in which the NYISO schedules an off line generator to start up, synchronize to the grid and run at or above its minimum output level. SCUC commits resources for the next day (posting at 11:00 AM a.m. for the Dispatch Day, which begins at Midnight), Real Time Commitment (RTC) can commit resources for the next hour (posting at 45 minutes before the Dispatch Hour), and Real Time Dispatch (RTD) has the ability to commit quick start resources in the corrective action mode (CAM). Supplemental Resource Evaluation (SRE) provides a method to commit supplemental resources at other times as needed. This includes:~~

- ~~▪—Deficiencies anticipated two to seven days ahead which will require long lead time generators to start up in advance (i.e., too early for SCUC).~~
- ~~▪—Day Ahead deficiencies anticipated after SCUC has begun or completed its Day Ahead evaluation (i.e.: too late for SCUC).~~

~~For In Day, it also includes:~~

- ~~▪—In Day deficiencies anticipated more than 75 minutes ahead (i.e.: too early for Real Time Commitment (RTC) to run).~~
- ~~▪—Real Time deficiencies that occur after RTC has begun or completed its Dispatch Hour evaluation and RTD/Reserve Pick Up has run.~~

~~SRE Objectives~~

~~The primary objectives of SRE Procedures are:~~

- ~~▪—Effectiveness in eliminating resource deficiencies~~
- ~~▪—Execution simplicity (i.e., "user friendliness"; with due regard for economic efficiency).~~

~~SRE Procedures~~

~~SRE procedures determine:~~

- ~~▪—When supplemental resources are needed~~
- ~~▪—Which supplemental resources are chosen~~

~~SRE Pre-Calculated Resource Replacement Charts~~

~~The NYISO prepares pre-calculated SRE charts, which list available resource replacements. The charts are computed and updated from current input to (but not output from) SCUC. They consist of a matrix of available resources sorted by:~~

- Type (i.e.: energy, regulation, operating reserves, and FRED)
- Location
- Start up time
- Availability in MW by hour

Within each of these categories, resources are sorted in order of average price for a given number of hours expected to be required. The price includes start up and minimum generation price bids, and takes minimum run times into consideration.

Use of Day-Ahead Bids for SRE

For its 2 to 7 Day Ahead commitment (before SCUC runs a Day Ahead commitment), SRE uses un-expired/unaccepted Day Ahead bids submitted with the recognition that a supplier with a three day start up would actually submit a "Day Ahead" bid four days ahead).

For Day Ahead commitments made after SCUC has begun its evaluation, SRE uses un-expired/unaccepted Day Ahead bids. It is important to understand that so called "Day Ahead" Bids may actually be submitted for use by SRE after the Day Ahead Market has closed. These are separate and distinct from Real Time bids that may have been submitted in advance. For the purposes of SRE, Day Ahead bids and Real Time bids are not applicable at the same time. Un-expired Day Ahead Market Bids automatically expire when the Real Time Market closes (i.e., 75 minutes before the Dispatch Hour).

Bid Changes

If a resource is selected by SRE and committed for a designated number of hours of operation, it may not raise (but it may lower) its bid price for the duration of that commitment.

NYISO Resource Monitoring Procedures

Regulation/ Reserve Level Monitoring

The NYISO monitors the level of regulation and reserve resources available to meet anticipated NYCA requirements.

Bid Adequacy Monitoring

The NYISO also tracks the level of un-expired/unaccepted resource bids by location as potential replacements for resources. If certain bid categories are deemed insufficient, the NYISO posts an announcement to market participants to solicit additional bids.

Monitoring SRE Events

Please refer to Section 4.4 Supplemental Resource Evaluation in the *NYISO Transmission & Dispatching Operations Manual**NYISO Transmission & Dispatching Operations Manual*.

For any SRE invoked by NYISO operators that could result in additional charges to any Market Participants, logs are kept indicating all actions taken and all selections (from

~~Resource Charts) made. Contemporaneous information—Resource Charts, Web posting of requests for resource bids, etc. also be kept.~~

~~Both NYISO Management as well as the Market Monitor reviews all such logs, requests, and charts to ensure that off-economic decisions are kept to a minimum or do not occur at all. The NYISO provides Market Participants with a quarterly report indicating any instances of off-economic actions, the approximate monetary effect, and what remedial actions have been or will be taken to prevent recurrences.~~

10.2 SRE Commitment Procedures

~~SRE shall only be used to address resource deficiencies; it shall not be used solely to reduce costs. The general SRE commitment procedure is as follows:~~

~~The following are the SRE commitment procedures. SRE is only used to address resource deficiencies in an economic fashion. See sections 10.4 and 10.5; it should not be used solely to reduce costs.~~

- ~~1) **Initiate SRE**—The NYISO proceeds with an SRE:

 - ~~a. If a resource deficiency occurs (or is anticipated to occur), and~~
 - ~~b. If regular Real Time non-SRE resource adjustments are (or are anticipated to be) inadequate, and~~
 - ~~c. If the problem is outside the windows of evaluation for both SCUC and RTC.~~~~

~~The resource deficiency may be a result of:~~

- ~~a. The subsequent loss of an energy, regulation, or reserve resource~~
- ~~b. The loss of a transmission facility~~
- ~~c. A load forecasting anomaly; and/or~~
- ~~d. A resource deficiency forecast but not evaluated by RTC.~~

~~**Define Replacement Required**—Based on the deficiency, the NYISO will determine:~~

- ~~e. Type of replacement required (i.e., regulation capability, operating reserve capability, or energy resource). In general, the replacement to be selected should match the resource lost.~~
- ~~f. Location that the replacement is needed~~
- ~~g. How soon the replacement is required~~
- ~~h. Amount in MW needed by hour~~
- ~~i. How long the replacement will be required.~~

Table 10-1: SRE Replacement Decision

SRE Replacement Decision (Resource replacements should be based upon resource deficiencies)	
Type of Resource Deficiency	Type of Replacement Required (To be Selected from Un-expired/Unaccepted Bids)
Energy Resource Deficiency	Energy in Acceptable Location
Regulation Resource Deficiency	Regulation in Acceptable Location

Operating Reserve Deficiency	Same Kind Replacement of Operating Reserves in Acceptable Location
FRED Deficiency	FRED - Acceptable Location

~~**Select Replacement Resources**—Based on the requirements determined above, the NYISO selects replacement resources from the pre-calculated SRE charts for available un-expired/unaccepted resources (see example chart in the NYISO Transmission & Dispatching Operations Manual).~~

~~**Note Exceptions**—If the NYISO's selection for supplemental resources diverges from the merit order indicated on the applicable chart, the NYISO will need to formally justify and log the exception.~~

~~**Solve Real-Time, In-Day, and Day-Ahead Deficiencies First, Second, then Third**—In the case in which SCUC has begun or already completed its execution, and a combination of Real-Time, In-Day and/or Day-Ahead resource deficiencies are subsequently anticipated, SRE is used to solve any Real-Time problems independently first. Conditions are then re-evaluated, and if needed, a second SRE is used to solve any In-Day problems next. This is followed, if necessary, by another re-evaluation and a third SRE to solve any remaining Day-Ahead problems.~~

~~**Allow But Don't Guarantee "Self"-Replacement by Resource Suppliers**—A resource that is financially obligated to serve a bilateral transaction or the LBMP spot market may wish to procure its own replacement if possible. In this case, it needs to arrange a Contract For Differences (CFD) contract with another resource that agrees to bid into the LBMP market. If that replacement resource were selected through SRE, the original resource would reach a side settlement with it. While the NYISO will not interfere with this type of arrangement, it will also be under no obligation to help facilitate this arrangement by delaying the implementation of SRE. Alternately, the SRE may select another source for the replacement; presumably, because it is a more economical and/or more effective replacement choice.~~

~~A resource committed by SRE is included in subsequent RTC databases.~~

10.3 Two to Seven Day Ahead SRE Procedures

A two to seven day ahead SRE is performed if operating capacity deficiencies are anticipated two to seven days ahead which will require long lead-time generators to start up in advance (i.e., too early for SCUC):

1) ~~**Post Announcement**—If a Pre-SCUC SRE is anticipated, and if time permits, the NYISO posts an announcement to market participants that a Supplemental Resource Evaluation is planned, and that additional resource bids are being solicited.~~

~~**Two to Seven Day-Ahead Operating Capacity**—If any deficiencies in Operating Capacity Resources are expected to exist that require long lead-time start ups (longer than Day Ahead), the NYISO will:~~

- a. Determine the amount and location of Supplemental Resources required.
- b. Determine how soon the Supplemental Resource will be needed.
- c. Determine how long (i.e., the Supplemental Commitment Period (SCP) in hours up to the end of the Dispatch Day) the Supplemental Resource is likely to be needed.
- d. Select and schedule the move of Supplemental Resources from available unexpired/unaccepted Day Ahead resource bids to FRED on a least cost basis where least cost equals lowest composite start up and minimum generation costs (if start up will be required) spread over the SCP for resources that will be available soon enough to meet the need. In cases in which all other factors are equal, the bid energy price is used as a tie breaker.

SCUC Re-Adjustment—Following Step #2 above, a subsequent SCUC run may re-adjust resources.

10.4 Post SCUC Day-Ahead SRE Procedures

A Day Ahead SRE is performed after SCUC has begun its Day Ahead evaluation when it becomes too late for SCUC to run:

- 1) **Post Announcement**—If a Day Ahead SRE is anticipated, and if time permits, the NYISO posts an announcement to market participants that a Supplemental Resource Evaluation is planned, and that additional resource bids are being solicited.

Day Ahead Regulation, Reserve or FRED Deficiency—If any deficiencies in regulation, operating reserves and/or FRED are expected to exist Day Ahead after SCUC execution begins and after allowing for regular Real Time resource adjustments, the NYISO will:

- a. Determine the amount, location and type of Supplemental Resources required. Type is the same kind of resource that is deficient.
- b. Determine how soon the Supplemental Resource will be needed.
- c. Determine how long (i.e., the Supplemental Commitment Period (SCP) in hours up to the end of the Dispatch Day) the Supplemental Resource is likely to be needed.
- d. Select and schedule the move of Supplemental Resources from unexpired/unaccepted Day Ahead bids to the appropriate resource category on a least cost basis where least cost equals lowest composite availability, and start up costs and minimum generation costs (if start up will be required) spread over the SCP for resources that will be available soon enough to meet the need. In cases in which all other factors are equal, the bid energy price is used as a tiebreaker.

Day Ahead Energy Deficiency—If an energy deficiency is expected to exist Day Ahead (after SCUC executes) which would result in a reserve deficiency after allowing for regular Real Time resource adjustments, the NYISO will:

- a. Determine the amount and location of Supplemental Resources required to eliminate the energy deficiency.
- b. Determine how soon the Supplemental Resource will be needed.

- c. ~~Determine how long (i.e., the Supplemental Commitment Period (SCP) in hours up to the end of the Dispatch Day) the Supplemental Resource is likely to be needed.~~
- d. ~~Select and schedule the move of Supplemental Resources from unexpired/unaccepted Day Ahead bids to energy on a least cost basis where least cost equals lowest composite energy and start up costs (if start up is required) spread over the SCP for resources that will be available soon enough to meet the need.~~

~~**Real-Time Commitment Re-Adjustment** — Following Steps #2 and/or 3 above, subsequent RTC runs may re-adjust resources.~~

SRE Pricing and Cost Allocations

Energy Payments

Resources committed by RTC or SRE are paid the real time LBMP for Energy and are guaranteed recovery of start up and minimum generation costs (for the balance of the day). As previously stated, a resource committed by SRE cannot raise (but may lower) its price bid for the duration of time it was committed.

Availability Payments

Resources committed by RTC or SRE are paid the higher of Day Ahead or the Real Time Marginal Clearing Price for reserve availability.

Cost Allocation

Assignment of replacement costs that result from a SRE is given as follows:

Table 11-2: Assignment of SRE Replacement Costs

Cause for SRE	Cost Assignment for Replacement Energy, Operating Reserves and/or Regulation	Cost Assignment for Supplemental Payments for Start-Up and Min-Gen (if any)
Loss of SCUC Day-Ahead Committed Resource	Charged to Lost Resource	Schedule 1 Uplift
Loss of RTC and/or SRE Committed Resource	Affects Real-Time Energy LBMP and/or Marginal Clearing Prices for Ancillary Services	Schedule 1 Uplift
Loss of Transmission that Results in Locational Resource Deficiency	Affects Real-Time Energy LBMP and/or Marginal Clearing Prices for Ancillary Services	Schedule 1 Uplift
Unexpected Load Increase	Affects Real-Time Energy LBMP and/or Marginal Clearing Prices for Ancillary Services	Schedule 1 Uplift
Simultaneous Combinations of Above	Pro-rata basis	Pro-rata basis

Attachment A: Calculation of Incremental Losses

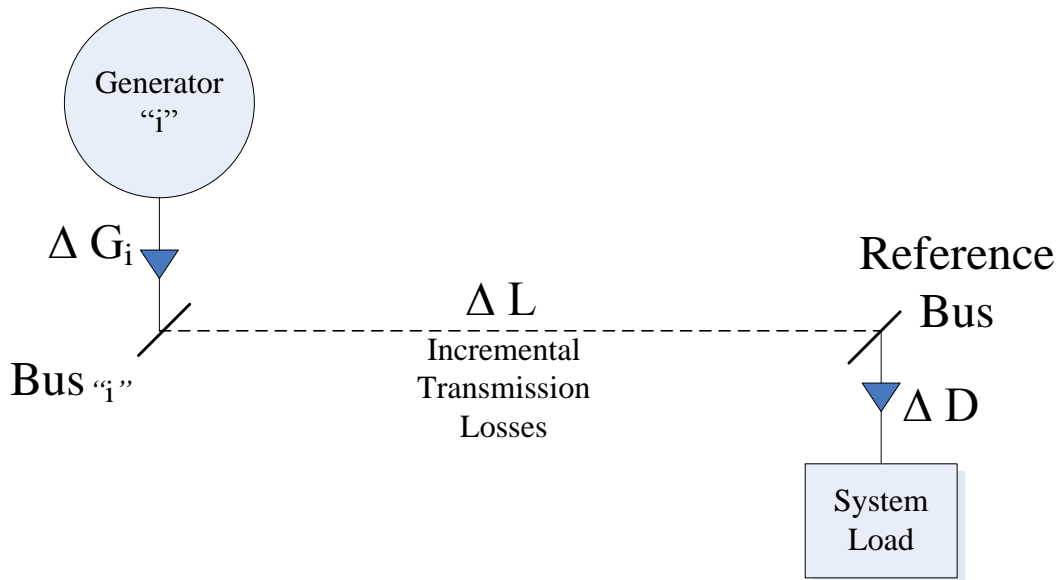

$$\text{Energy Balance : } \Delta G_i = \Delta D + \Delta L$$

Figure 44A-31: Incremental Transmission Losses

Calculation of Incremental Losses

The marginal (or incremental) effect of real power transmission losses is taken into account by the SCUC for the Day-Ahead Market, Real-Time Market, and Real-Time operations. Losses occur in the transmission system as energy flows from generation sources to the loads. These losses appear as additional electrical load, requiring the generators to produce additional power to supply the losses. The amount of losses that occur on specific transmission lines or ~~areas of the transmission network at any given time~~ areas of the transmission network at any given time are dependent on network topology and the specific generation sources being used to meet the load at that time. [Figure A-1](#) illustrates the concept of incremental losses:

The elements in [Figure A-1](#) are defined as follows:

ΔD = an increment of load at the reference bus with all other loads held constant

ΔG_i = the increment of generation at bus "i" that is required to supply the increment of load at the reference bus

ΔL = the increment of transmission losses resulting from the transfer of power from the generator to the reference bus load.

Penalty Factors The Penalty Factor for generator "i" is defined as the increase required in generator output at Bus "i" to supply an increase in load at the reference Bus with all other loads held constant, or:

$$PF_i = \Delta G_i / \Delta D$$

Which, from the energy balance relationship, can also be defined as follows:

$$PF_i = 1 / (1 - \Delta L / \Delta G_i)$$

Generator Energy bid prices are multiplied by Penalty Factors to account for incremental transmission losses in the dispatch process.

Delivery Factors **The Delivery Factor for Generator “i” is defined as follows:**

$$DF_i = \Delta D / \Delta G_i$$

Which, is related to Penalty Factor as follows:

$$DF_i = 1 / PF_i$$

Delivery Factors are used to calculate the marginal loss components of the LBMPs.

Losses Associated with External Transactions

External Generators and Loads can participate in the LBMP Market or in Bilateral Transactions. External Generators may arrange Bilateral Transactions with Internal or External Loads and External Loads may arrange Bilateral Transactions with Internal Generators. Charges for marginal losses for each of these types of transactions (LBMP Market or Bilateral) are limited to losses inside the NYCA. The Generator and Load locations for which LBMPs are calculated are initially limited to a pre-defined set of buses External to the NYCA. The marginal losses component for these LBMPs are calculated from points on the boundary of the NYCA (Interconnection buses) to the reference bus.

The marginal losses component of the LBMP at each External bus are a weighted average of the marginal losses components of the LBMPs at the Interconnection buses. To derive the marginal losses component of the LBMP at an External location, a hypothetical transaction ~~will be~~ scheduled from the External bus to the reference bus. The Shift Factors for this transaction on the tie lines into the Interconnection buses, which measure the per-unit effect of flows over each of those tie lines that result from the hypothetical transaction, provide the weights for this calculation. Since all the power from this hypothetical transaction crosses the NYCA boundary, the sum of these weights is unity. The sum of the products of these weights and the marginal losses component of the LBMP at each of these Interconnection buses yields the marginal losses component of the LBMP that are used for the External bus.

Attachment B: NYISO Load Forecasting Model

NYISO Load Forecasting Model

The NYISO Load Forecasting Model (LFM) is designed to meet a number of objectives. Perhaps most important of the objectives is the ability to forecast hourly loads for the day-ahead market. This particular need encompasses not only the loads for the New York Control Area (NYCA), but also the loads for each of the eleven zones that comprise the NYCA. Other objectives extend the geographic purview of the model and the timeframe for the forecasts.

The geographic reach of the model will be extended to ~~sub-zones or transmission districts within~~ each zone within the NYCA. Since the NYISO auction model turns on location based marginal prices (LBMP), there needs to be a mechanism to support the determination of those prices. The market-clearing price will be determined by the supply and demand for power. Since both supply and demand for power have geographic aspects, the system that provides (expected) demand information to the auction process needs geographic aspects as well.

The timeframe needs of the electricity market are quite varied, and a modeling system to support that market must also function within the various timeframes. In addition to the day-ahead market, there is a need for week-ahead demand information since some generating facilities may take that long to become fully functional. There is a need to understand what is likely to happen during a capability period since capacity may need to be procured to meet reliability requirements. ~~Extending this thought, it~~ It is important to understand the demand and energy profile for the entire calendar or capability year so that rational planning can take place. Finally, in the arena of longer timeframes, a five to ten year horizon meets NERC standards and allows planning for capacity to be sited and built. Retreating from the long run towards the very shortest runs, we need to understand demand in the balancing markets and in situations of highly changeable weather. These analyses would logically take place during the day in question.

There are also a number of technical objectives for the modeling system. For day-ahead forecasting, it needs to be convenient and transparent to run, in order to feed information in a timely manner to market participants and to the SCUC process. The model must be accurate to within the limits of statistical and econometric models; forecasts of weather and economic activity that drive the LFM are likely to have ~~errors, which means errors, which mean~~ that actual loads will deviate from forecasted loads. The modeled loads need to be within an acceptable range of the actual loads after controlling for weather and economic activity. Thus, another objective is that the performance of the model can be assessed easily and quickly so that adjustments can be made appropriately. The economic components of the model structure should conform to good economic theory and practice so that the system can also yield information that is useful for policy analysis.

A Unified System

Despite a large number of seemingly disparate objectives, the unifying theme is one of providing information about future loads and energy demands across the NYCA. With this theme as backdrop, the NYISO decided that a unified modeling system using one set of equations, drivers, and historical information would best serve its information needs. In particular, using one comprehensive data set eliminates inconsistencies and the need to try to align data from different sources.

As the rest of this attachment will illustrate, creativity in model construction allows appropriate data to drive the model in the relevant timeframe. Certainly, weather is extremely important in the short run, while economic and secular data play a stronger role in the medium and longer run. What makes the system unified is that weather does not disappear in the long run (design weather is used for some scenario planning) nor does economic activity disappear in the short run (economic activity is fixed at some level for capability considerations and next day analysis).

Schematic Model Flow

The central objective of the model is to forecast hourly loads in each of eleven zones and the NYCA for the next day. Peak load and total energy consumption for the next day are extremely important ancillary objectives and might, under some circumstances, be derived from the hourly loads. In fact, the LFM uses a “~~top/down—bottom/up~~” approach which pays explicit attention to peak load and energy at ~~the NYCA and zone levels, and obtains the NYCA level by summing over the zones.~~ This approach uses state or NYCA information when it contributes well to the model’s ~~structure,structure~~ and zone information when it plays a premier role. Once the peak load and daily energy are obtained, a series of hourly interval models are determined, comprised of four fifteen-minute interval models for each hour of the day.

The model’s structure flows from daily peak and energy at the ~~system (NYCA)zonal level, to hourly loads at the system level, to daily energy at the zone level,~~ to hourly interval loads at the zone level. Part of the ~~top/down flow modeling process~~ is by inclusion of predicted values of peak or energy into the hourly interval load models at the NYCA level, from the NYCA to the zones, and in the zones as isolated units. ~~The bottom/up component comes from using zone hourly loads and the zone’s share of load in an adjustment process that takes advantage of high quality information at the NYCA level to adjust the zone hourly loads. The next paragraphs clarify this approach.~~

The ~~NYCA-levelzonal~~ daily peak load and energy are specified as functions of weather, economic activity, day-type, and an installed energy-consuming equipment base (Estimation procedures are discussed below). The predicted ~~system-zonal~~ peak and energy requirements then become part of the driver set of the ~~NYCA-levelzonal~~ hourly interval load models. Peak load and energy requirements in the driver sets serve to ~~restrain-constraint~~ the hourly interval loads to be consistent with the previously determined peak and energy requirements.

~~The next step is to model and predict zone daily energy, based on the zone drivers analogous to those at the NYCA level. Zone energy requirements then feed into zone hourly models, again as part of a driver set analogous to that at the NYCA level.~~ At this point there are eleven sets of (2496) hourly interval zone load models and one set of (2496) NYCA-level hourly interval load models (in addition to eleven zone energy models, one NYCA-level model for peak load, and one NYCA-level model for energy)model obtained by summing over all the zones.

Coordination between the zones and the system level comes at the next step. For each hour, each zone's share of the total load is determined by dividing the zone's hourly load by the sum of the eleven zone loads. That share is then multiplied by the NYCA level hourly load. The result of multiplying zone shares by system hourly loads is an adjusted zone hourly load. This adjusted zone load has two desirable properties. First, the adjusted zone loads will sum up to the NYCA-level load, and second, the relations of the zones to each other are preserved.

The ~~top/down elements~~ "bottom-up" methodology utilizes the detailed information at the NYCA level and preserves the resulting profiles and forecasts for the unique behavior of each zone. They also allow for a strong concordance between peak load and energy, and hourly interval loads. ~~The bottom/up elements highlight zone-specific activity and preserve the relative ordering of loads throughout the NYCA.~~

Data Considerations

Since this attachment is not a tutorial on load forecasting methodologies, it is not useful to go into too much detail about particular data series or estimation methods, but some description of each can help to illuminate the process. The core of the modeling system is the next day hourly interval load forecast, and naturally, the central data set is the set of hourly interval loads for the system and for the zones. ~~Analysts felt that the period from January 1993 or 1994 through December 1998 would provide~~ Load data from three to four recent historical years provide sufficient experience to yield acceptable estimates of the parameters associated with the drivers of the various models. ~~Shorter periods will better capture more recent weather-response characteristics while longer periods will better capture weekday, weekend and holiday seasonal daily and hourly load profiles.~~ The challenge for modeling and estimation was to obtain data with hourly interval frequency or construct other data to have the required frequency. The key drivers for the day-ahead models are weather and day-type. ~~Our~~The weather information ~~vendor/forecast provider~~ was able to supply a number of variables with an hourly frequency, for example, dry bulb temperature, wind speed, cloud cover, dew point, wet bulb temperature, humidity, and barometric pressure. ~~However, it is not necessary to model or forecast weather at sub-hourly intervals.~~

The interaction of load and weather can be quite subtle, requiring consideration of build-up effects, daily averages, recognition of maxima and minima, etc. The availability of the hourly information listed above enabled the construction of transformed data ~~so as to~~ meet the needs of modelers.

Table B-1 is an example of actual and forecasted weather for Albany International Airport, the official weather collection site for Albany County. Note that the minimum, maximum, and average values of the variables are determined over twenty-four hourly observations. The data for 15 April, 1999 is the set of actual observations, while the data for 16 – 25 April, 1999 is a forecast.

Table 44B-41: Albany Airport Actual and Forecasted Weather

DATE	MIN TMP	MAX TMP	AVG TMP	MIN DPT	MAX DPT	AVG DPT	MIN HUM	MAX HUM	AVG HUM	MIN WEB	MAX WEB	AVG WEB	MAX WSP	AVG WSP	AVG CLC
Apr. 15, 1999	28	62	48	17	32	24	18	89	47	27	44	38	18	7	33
Apr. 16, 1999	37	51	45	29	33	30	43	76	56	27	44	38	13	6	63

Apr. 17, 1999	40	57	48	34	39	37	46	96	68	27	44	38	13	9	79
Apr. 18, 1999	40	56	48	36	37	37	49	89	66	27	44	38	10	8	77
Apr. 19, 1999	36	53	45	36	37	37	36	100	72	27	44	38	12	8	75
Apr. 20, 1999	39	58	48	35	36	35	42	89	64	27	44	38	8	7	65
Apr. 21, 1999	36	62	49	33	35	34	35	92	59	27	44	38	9	7	59
Apr. 22, 1999	39	65	52	31	33	32	29	76	49	27	44	38	8	7	54
Apr. 23, 1999	42	69	56	30	31	31	24	65	41	27	44	38	11	8	52
Apr. 24, 1999	43	68	55	30	30	30	24	60	40	27	44	38	10	8	40
Apr. 25, 1999	41	64	52	30	40	35	36	86	54	27	44	38	10	7	30

The system level zonal forecast models use weather information gathered from seventeen weather stations across New York. The data from the stations is aggregated appropriately to best represent each zone. Thus, the information from those seventeen sites is combined into eleven zone weather sets and one state-level weather set. Tables B-2 and B-3 show the state and zone weighting schemes.

Table 44B-52: Each Zone's Zonal Share of New York State's 2010 Population

ZONE	POPULATION (IN %) (000)	Percent
A - WEST	8,81,532	7.9%
B - GENESE	5,31,003	5.2%
C - CENTRL	7,71,384	7.1%
D - NORTH	782	0.4%
E - MHK VL	5,48,991	4.6%
F - CAPITL	6,41,215	6.2%
G - HUD VL	6,31,372	7.0%
H - MILLWD	2,41,990	1.0%
I - DUNWOD	2,47,600	3.9%
J - N.Y.C.	40,78,186	42.1%
K - LONGIL	14,52,835	14.6%
TOTAL	400,19,450	100.0%
DOWNUpstate (A-F)	66,36,107	31.4%
UPDownstate (G-K)	33,713,343	68.6%

Table 44B-63: Weather Station Weights Imputed to Each Zone

Zone	Stations	Station Weight
A - WEST	Buffalo	91%
	Elmira	5%
	Syracuse	4%
	Total	100%

Zone	Stations	Station Weight
B - GENESE	Elmira	5%
	Rochester	85%
	Syracuse	10%
	Total	100%
C - CENTRL	Binghamton	23%
	Elmira	14%
	Syracuse	55%
	Watertown	9%
	Total	100%
D - NORTH	Plattsburgh	100%
E - MHK VL	Binghamton	20%
	Massena	17%
	Monticello	13%
	Utica	35%
	Watertown	15%
	Total	100%
F - CAPITL	Albany	76%
	Binghamton	3%
	Plattsburgh	5%
	Poughkeepsie	6%
	Utica	10%
	Total	100%
G - HUD VL	Newburgh	68%
	Poughkeepsie	27%
	White Plains	4%
	Albany	2%
	Total	100%
H - MILLWD	White Plains	100%
	Total	100%
I - DUNWOD	White Plains	100%
J - N.Y.C.	JFK	21%
	LGA	79%
	Total	100%
K - LONGIL	Islip	100%

Day-type information in the form of binary indicator variables came from a master daily calendar. Holidays and the days surrounding holidays were also available through this master calendar. This kind of information is represented by binary variables, which indicate that a given day either is or is not a particular day of the week, or a particular holiday.

Economic data at the state, metropolitan area or county level is available at best on a monthly basis, in the case of employment, and on a quarterly or annual basis for other kinds of information. This frequency did not pose a real problem since economic activity can be considered fixed in the very short run. In order to incorporate levels of economic activity into

the model in the short run (peak loads or daily energy), and changes in activity as the short run unfolds into the long run, the appropriate economic variables were converted (from monthly, quarterly, annually) to daily values which remained constant until a new value emerged, employment in the next month, for example.

The constancy of economic data in the very short run, combined with its variability in the medium and long run, allows the use of the same model as the time horizon unfolds. Weather data can be used in a similar way. As discussed above, weather is certainly a major driver of day-ahead and week-ahead load, and weather data is available as a forecast to feed into the driver side of a load or energy forecasting model as a set of assumptions. Longer run weather forecasts are much less certain, even for a month ahead, let alone a season, capability period, year, or decade.

For these planning periods, we incorporate the concept of design weather into the model. While each day or month can differ in accord with the design characteristics, the design pattern can be held constant for planning purposes. In fact, atypical weather patterns as well as typical or design patterns can be incorporated into the model for purposes of comparative analysis. So, analogous to the way in which economic data is fixed in the short run, weather patterns can be fixed in the longer run. It is the pliability of the model drivers that allows the use of the same model structure over very different timeframes.

As described above, the LFM actually aggregates weather from seventeen stations across New York into eleven zone points based on population and other historical weighting factors.

Economic data comes from our economic forecasting vendor and are-is provided at the state, MSA, and county levels for subsequent aggregation into zones.

Estimation Processes

To articulate the LFM, we incorporated data into the appropriately specified equation systems via statistical estimation procedures. The intent here is straightforward. The estimation process should lead to a set of model equation parameters, which minimize the (sum of squared) errors between the actual loads and what the model predicts for load under the circumstances defined by the driver variables.

The LFM goes beyond traditional regression analysis to incorporate a technique known as “artificial neural net” (ANN) analysis. By taking a sophisticated non-linear approach to the estimation of the model’s parameters, ANN analysis allows a model to be “trained” and to “learn” from its experience as it estimates the parameters. Training takes place when a specification is articulated and parameters are estimated using a given data set. Learning takes place when new data is incorporated into the data set and the original specification is maintained. Learning can often result in some small adjustments to parameters as a result of the new experience (data). It is an efficient way to update a model without expending effort on a re-specification.

~~The LFM actually incorporates both ANNs and traditional regression methods to articulate a system that has the correct directional responses to changes in the driver variables. At the NYCA level, we model peak and energy using ANNs while the NYCA hourly load forecasts derive from regression models. At the zone level, we use ANNs to model energy requirements while regression analysis is used for the hourly loads. The ANNs can exploit the richness of the data~~

and the subtlety of interactions inherent in modeling load and energy. The hourly specifications are more parsimonious and lend themselves well to regression analysis.

Using the Model

As described above, there are a number of uses planned for the LFM. The primary use will be in the Operations Planning Department. The operations planners will be running the LFM on a daily basis as a prelude to market participants' bids into the day-ahead market. Both the forecasts and the subsequent bids become inputs into the SCUC, which will determine market clearing prices and dispatch profiles. Current plans call for closing the day-ahead market at 5AM. Thus, the LFM will have to run before that. In order for the LFM to run, it will need a forecast of weather. Our weather information vendor will be supplying a weather forecast possibly around 2 a.m. or 3 a.m. The outcome of this process is that the day-ahead load forecast will be as timely as possible for market participants, and will be based on information that is as current as possible.

The Analysis and Planning Department will also be using the model to develop planning scenarios as elements in the understanding of the need for future installed capacity and transmission capability. Additionally, Analysis and Planning will be using the model to respond to a variety of questions posed by senior management, typically exploring different aspects of system peaks and energy.