



Automated Mitigation

Concept of Operation

Author:	Reviewer(s):
R. de Mello J. Savitt	LECG Staff Potomac Economics Staff

Project Sponsor:	Point of Contact:
M. Calimano V. Budd	R. de Mello

Document Locator:
A620\COO_AutomatedMitigation.doc

Revision History:	
Date:	Additions, deletions, modifications:
June 17, 2003	First draft
<u>31 July 2003</u>	<u>Second draft: fixed typos. Wording changes in 1, 1.1, 2, 2.1.2, 4.1, 5.1.3, 6.1.2, 6.2.</u>

Table of Contents

1	Introduction	1
1.1	Summary of New Features.....	1
1.2	Terminology.....	1
2	Super Zones and Load Pockets	2
2.1.1	NYCA Super-Zones	2
2.1.2	NYC Constrained Area	2
3	Automated Mitigation Process	3
3.1	Day-Ahead Process	3
3.2	Real-Time Process.....	4
4	Arming.....	6
4.1	Arming of NYCA Super-Zones.....	6
4.2	Arming Within the NYC Constrained Area.....	7
5	Conduct	7
5.1.1	Incremental Energy Conduct Test	7
5.1.2	Start-Up Cost Conduct Test.....	8
5.1.3	Minimum Generation Cost Conduct Test	8
6	Impact.....	9
6.1	Price Impact	9
6.1.1	NYCA Energy Price Impact	9
6.1.2	Load Pocket Energy Price Impact.....	9
6.2	Guarantee Payment Impact.....	9
7	Portfolio Exclusion	10
8	Mitigation.....	<u>11</u>
8.1	Day-Ahead Mitigation Duration.....	<u>11</u>
8.1.1	NYCA Super-Zones	<u>11</u>
8.1.2	Load Pockets.....	11
8.2	Real-Time Mitigation Duration.....	11

1 Introduction

The purpose of this document is to describe the Automated Mitigation Processes (AMP) both existing and planned. Portions of the day-ahead AMP (DA-AMP) have been implemented in previous projects. This document describes the vision for the DA-AMP in Zone J. A ~~an interim~~ real-time AMP (RT-AMP) has been applied to the zone J (NYC) generating units. While the mitigation standards under the Tariff will remain the same, the ~~interim~~ RT-AMP will undergo significant modifications in the coding of mitigation with the replacement of the current real-time systems (BME and SCD) with a new real-time system. This document also describes the vision for the real-time AMP outside Zone J.

1.1 Summary of New Features

Major changes to the automated procedures that are in place as of this writing are:

- DA-AMP
 - The DA-AMP will test load pockets in the NYC constrained area for mitigation. This replaces the in-city mitigation that is triggered when in-city energy prices exceed 107% of the price at IP2.
 - The portions of generating units that supply spinning reserve are no longer excluded from ~~mitigation~~ DA-AMP.
 - The DA-AMP will provide special treatment for startup cost late in the day. Startup cost, rather than minimum generation cost, will be used to express a generator's unwillingness to start late in the day. Minimum generation cost will no longer receive special treatment.
 - The DA-AMP will examine guarantee payments and may invoke mitigation based on guarantee payment impact.

- RT-AMP
 - The RT-AMP applies a new impact test to load pockets within the NYC constrained area. The new test is based on a change in energy price. This LBMP test replaces the ~~cumulative congestion~~ current proxy impact test.
 - The RT-AMP is expanded to test the NYCA super-zones

1.2 Terminology

Term	Description
AMP	Automated mitigation procedure
Base-set	As-received bids and offers
BME	Balancing market evaluation
DA-AMP	Day-ahead automated mitigation procedure
IP2	Indian Point #2
LBMP	Locational based marginal price
Mit-set	As received bids and offers modified so that any bid or offer that trips the conduct test, with subsequent impact, is replaced by its reference
NYC	New York City
NYCA	New York control area
Ref-set	As received bids and offers modified so that any bid or offer that trips the conduct test is replaced by its reference
RT-AMP	Real-time automated mitigation procedure
RTC	Real-time commitment
SCD	Security constrained dispatch
SCUC	Security constrained unit commitment
UC	Unit commitment

2 Super Zones and Load Pockets

The four super-zones that have previously been defined for the day-ahead AMP will also be **applied assessed** in real-time. In addition, load pockets will be associated with constrained facilities or interfaces in pre-defined constrained area(s). Currently, only Zone J is a pre-defined constrained area.

2.1.1 NYCA Super-Zones

The NYCA has been divided into four nesting locations, called super-zones. These super-zones, shown in [Figure 1](#), will be used by both DA-AMP and RT-AMP.

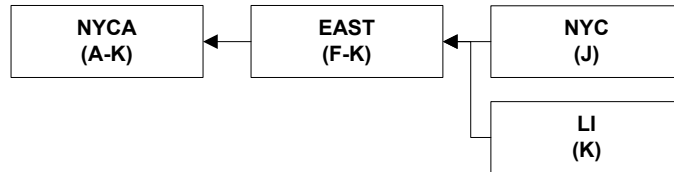

Figure 1. NYCA Super-Zones

It is possible that the number of NYCA super-zones may be increased in the future to accommodate changes in the prevailing congestion patterns. One possible change is shown in [Figure 2](#).

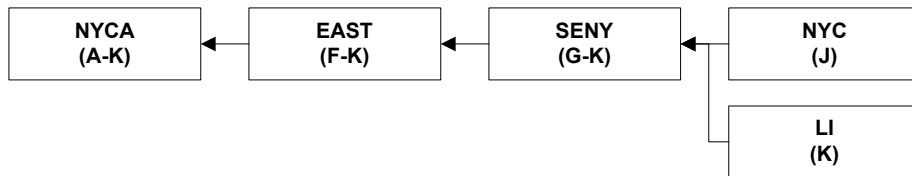

Figure 2. Possible Future NYCA Super-Zones

2.1.2 NYC Constrained Area

Zone J, the New York City area, has been designated as a “constrained area” and is subject to special mitigation rules because of the size of the thresholds that apply to “load pockets.” Zone J is currently composed of nine “load pockets” whose boundaries contain the prevailing constrained facilities (lines, cables, transformers, etc.) within the zone. These are shown in [Figure 3](#) and form a telescoping set.

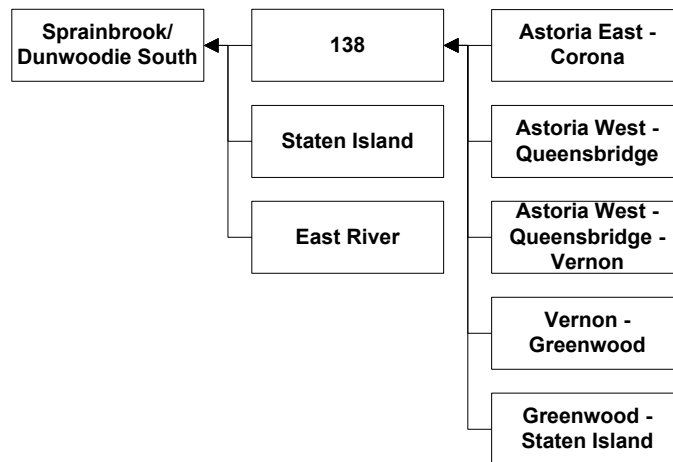

Figure 3. Load Pockets of the NYC Constrained Area

Associated with each load pocket is:

- A set of the facilities that define the boundary of the pocket and may become constrained
- A set of generating units that are able to relieve the load pocket's facilities if constrained
- A threshold used for conduct and impact tests

3 Automated Mitigation Process

3.1 Day-Ahead Process

Automated mitigation relies on a second unit commitment (UC) evaluation to assess the impact of mitigation; and a third UC to produce a final schedule. Thus, three UC executions are required. The first determines the prices and schedules that would occur with the original set (Base-Set) of bids and offers. The second determines the prices and schedules that would occur with a reference bids and offers wherever conduct warrants (Ref-Set). Differences between Base-Set and Ref-Set are used to determine price impact. The third UC determines final prices and schedules using mitigated bids and offers (Mit-Set) where both conduct and impact warrant mitigation. The SCUC as DA-AMP processes are shown in [Figure 4](#) [Figure 4](#) and [Figure 5](#) [Figure 5](#) [Figure 5](#).

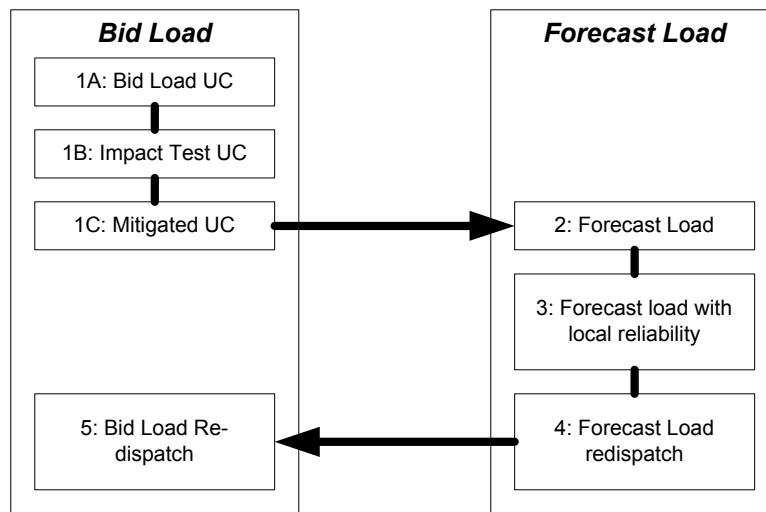

Figure 4. SCUC Process Overview

[Figure 5](#) [Figure 5](#) [Figure 5](#) presents the elements of the first SCUC pass in more detail. The second of the three pass 1 unit commitments is both preceded and followed by tests and evaluations. These are:

- Pre-UC2 Processing
 - Detect load pockets in NYC congested area
 - Assign threshold to generators
 - Conduct test of incremental energy offer
 - Conduct test of startup offer
 - Conduct test of minimum generation offer
 - Evaluation of the portfolio exclusion
 - Guarantee payment impact test
 - Preparation of inputs for UC2 (Ref-Set)
- Post-UC2 Processing
 - Energy cost impact test (superzones)
 - Energy cost impact test (NYC constrained area)
 - Conduct test of incremental energy offer

- Guarantee payment impact test
- Preparation of inputs for UC3 (Mit-Set)

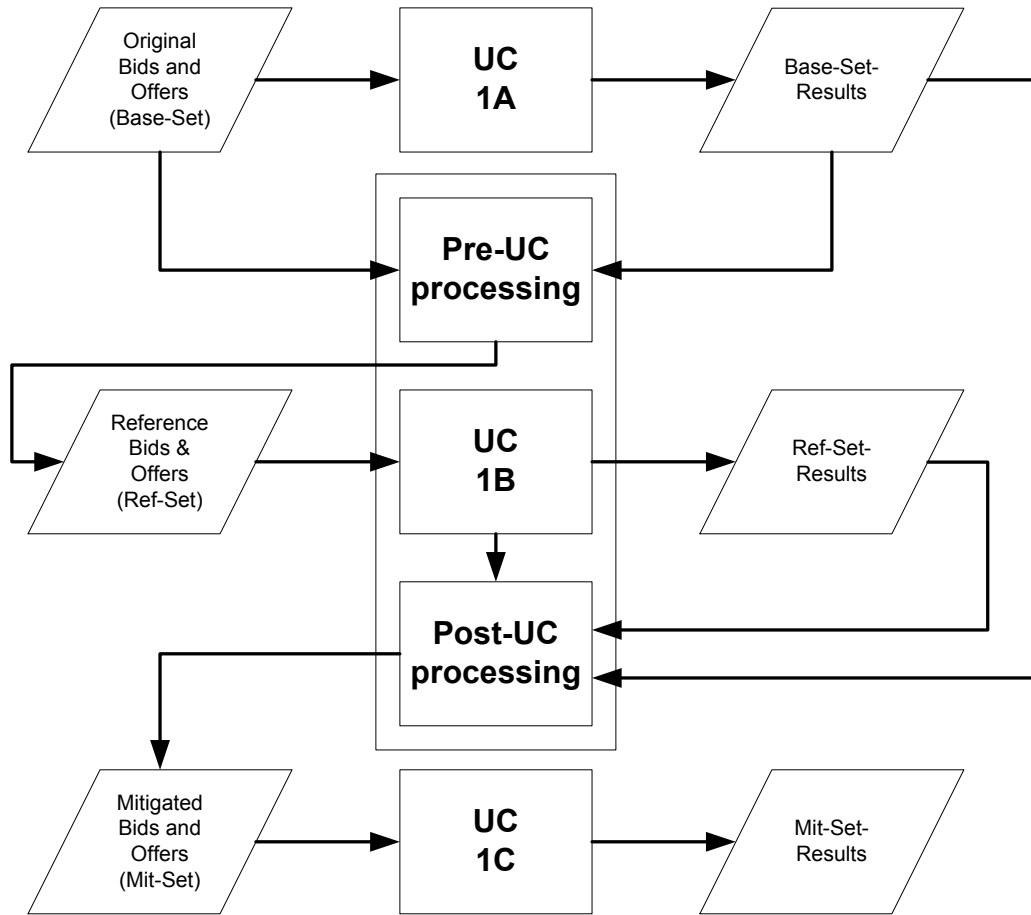

Figure 5. SCUC Pass 1

3.2 Real-Time Process

Automated mitigation relies on a second unit commitment evaluation to assess the impact of mitigation. Thus, two unit commitment executions are required at each time step. The first determines the prices and schedules that would occur with the original set (Base-Set) of offers. The second determines the prices and schedules that would occur with a mitigated set (Ref-Set) of offers. The combined execution times of the unit commitments needed to evaluate both Base-Set and Ref-Set is likely longer than the RTC interval (15 minutes). However, each commitment can be executed as a separate process so they can be run in parallel as shown in [Figure 6](#). The advantage is that a full RTC cycle (15 minutes) can be used to evaluate impact; hence timing concerns are minimized. When done in parallel, the possibility of mitigation would be tested for the next RTC cycle (15 minutes) in the future. RTC_{15} and $RT-AMP_{15}$ would perform unit commitment evaluations simultaneously. Results of RTC_{15} and $RT-AMP_{15}$ would then evaluate for impact and, if mitigation were necessary, mitigated offers would be sent to RTC_{30} . Mitigation of offers for RTC_{15} would have been decided previously by $RT-AMP_{00}$.

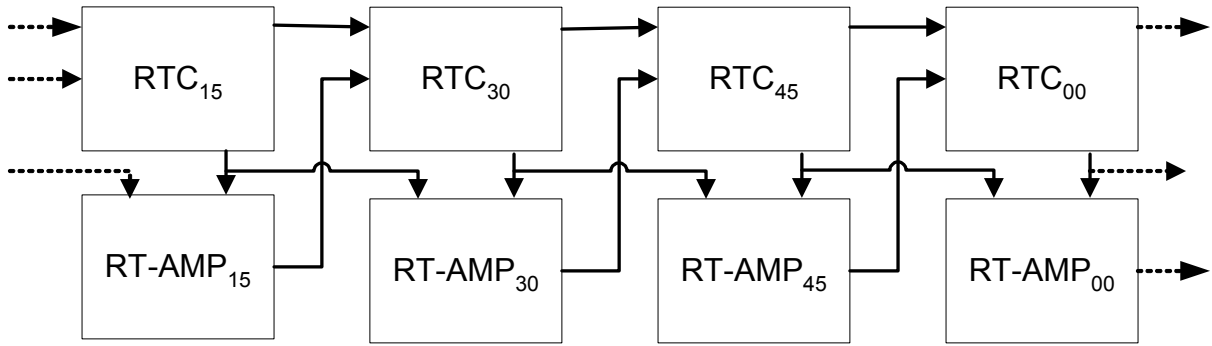

Figure 6. Parallel Impact Test

A third unit commitment is required to assure that prices and schedules are consistent with the final set of offers, some of which may be mitigated. When the test is conducted in parallel, only one, instead of two, additional unit commitments are required in each RTC cycle. As shown in [Figure 7](#), for the time period 15 to 30, Base-Set and Mit-Set are identical. RTC_{15} provides the base case unit commitment. Simultaneously $RT-AMP_{15}$ calculates the reference unit commitment, conducts the impact test, and determines the actual set of resources whose offers are to be mitigated (Mit-Set). Finally, RTC_{30} ensures that the commitment is consistent with the set of mitigated offers. Subsequently Mit-Set is used as the Base-Set and RTC_{30} would provide the base case for $RT-AMP_{30}$ and so on.

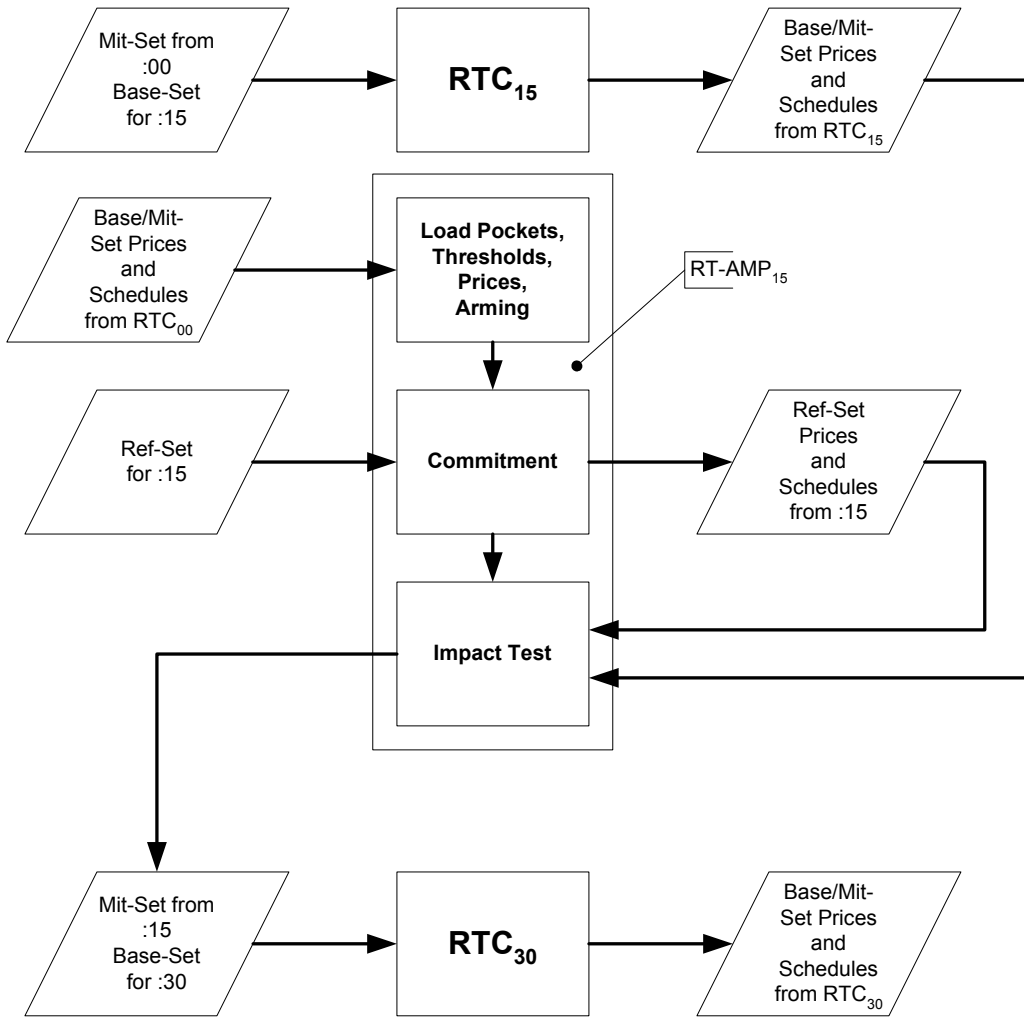

Figure 7. Parallel Impact Test 15 to 30 Minutes

4 Arming

The arming test makes an initial determination of whether mitigation is likely to result in a material price impact. Subsequently the impact test verifies a material price impact, whether on LBMP or on a portion of the congestion component of LBMP.

4.1 Arming of NYCA Super-Zones

The arming threshold ($RTCB_1$) for the super-zones of the NYCA currently has a value of \$150.00 ~~for DA-AMP. That arming shall be used for both DA-AMP and RT-AMP.~~

- Energy resources in zones A-K shall be evaluated for conduct and energy price impact if the price at any generator in zones A-E is $RTCB_1$ or higher in any interval;
- Energy resources in zones F-K shall be evaluated for conduct and energy price impact if the price at any generator in zones F-I is $RTCB_1$ or higher in any interval;
- Energy resources in zone J shall be evaluated for conduct and energy price impact if the price at any generator in zone J is $RTCB_1$ or higher in any interval;

- Energy resources in zone K shall be evaluated for conduct and energy price impact if the price at any generator in zone K is $RTCB_1$ or higher in any interval;

~~The conduct tests and guarantee payment impact test shall be performed regardless of the arming criteria for the energy price impact test. The \$150 arming threshold applies only to the mitigation of incremental energy offers. There is no threshold for examining and impact for guarantee payments.~~

4.2 Arming Within the NYC Constrained Area

The arming process activates the automated mitigation logic. A load pocket will be armed, that is, will be evaluated for possible mitigation, if the criteria below are satisfied for any interval during an hour. Arming shall apply to whole hours consistent with the offer period.

1. The facility/interface is constrained in an interval, and
2. The local congestion at any energy resource within the load pocket exceeds the threshold associated with the facility that spawned the load pocket.

The “local congestion” at the site of an energy resource within the NYC constrained area is then the difference in the congestion components at the energy resource and reference locations. That is:

$$LC_g = [C_g - C_r]$$

Where:

Term	Description
LC_g	Local congestion at the site of energy resource “g”
C_g	Congestion component of LBMP at the site of energy resource “g”
C_r	Congestion component of LBMP at the reference site

5 Conduct

The conduct tests compare offers of suppliers for start-up, minimum generation, and incremental energy ~~with to~~ references levels for those quantities. Differences are compared to thresholds to determine whether conduct ~~suggests indicates~~ the economic withholding of resources ~~or the attempt to exercise market power~~. Conduct tests are ~~established specified in the Market Monitoring Plan and are not expected to change Attachment H of the Services Tariff; other than to define how special thresholds may be applied to load pockets with a designated constrained area.~~ An energy resource may be associated with several load pockets, each of which has a threshold value. In such a case the conduct test ~~shall use uses~~ the smallest of the several thresholds.

5.1.1 Incremental Energy Conduct Test

An incremental energy offer will trip the conduct test if at least one of the following conditions is satisfied. The tests must be applied over the entire operating range of the generator’s offer. Some portions of the offer might trip the conduct test while other portions of the offer do not trip the conduct test.

- The offer is greater than the reference by a fixed percentage ($CTIE_1$), that is:

$$100 \times \left[\frac{\text{Offer} - \text{Reference}}{\text{Reference}} \right] > CTIE_1$$

- The offer is greater than the reference by a fixed amount ($CTIE_2$), that is:

$$[\text{Offer} - \text{Reference}] > CTIE_2$$

The values of $CTIE_1$ and $CTIE_2$ are set in the market mitigation plan and currently have the values tabulated below.

Constant	Value
CTIE ₁	300%. The difference between offer and reference must be greater than 300% of the reference. (This is equivalent to saying that offer must be 400% of reference price or greater.)
CTIE ₂	<ul style="list-style-type: none"> \$100.00 for the NYCA superzones; A value between \$0.01 and \$100.00 for load pockets of congested area(s).

2.3.1.35.1.2 Start-Up Cost Conduct Test

A startup offer will trip the conduct test if the following condition is satisfied. The test must be applied over the entire operating range of the generator's offer. Some portions of the offer might trip the conduct test while other portions of the offer do not trip the conduct test.

- The offer is greater than the reference by a fixed percentage (CTSU₁), that is:

$$100 \times \left[\frac{\text{Offer} - \text{Reference}}{\text{Reference}} \right] > CTSU_1$$

Start-up reference cost must be adjusted upward for any unit that may be started late in the day bid production costs are not guaranteed past midnight. These units legitimately increase their start-up cost late in the day, consistent with their minimum run time, to recoup these costs after midnight. Start-up costs will be exempt from the AMP for hours beginning T_{mg} and later.

Constant	Value
T _{mg}	20:00 hours local time

2.3.1.45.1.3 Minimum Generation Cost Conduct Test

The minimum generation offer is specified using two numbers: minimum generation level (MW), and minimum generation cost (\$/Hour). The generating unit's ~~incremental average~~ cost of energy while operating at minimum output is:

$$\left[\frac{\text{Minimum_Generation_Cost}(\$/\text{Hour})}{\text{Minimum_Generation_Level}(MW)} \right]$$

The conduct test for minimum generation cost requires a reference cost (\$/hr) for each generator. The reference cost is indexed by minimum generation level. A generator will trip the conduct test for minimum generation cost if its offer is:

- Greater than a fixed multiple (CTMG₁) above its reference minimum generation and energy offer production cost at its current minimum generation offer quantity, or
- Greater than a fixed amount (CTMG₂) above its reference minimum generation and energy offer production cost at its current minimum generation offer quantity.

The values of CTMG₁ and CTMG₂ are set in the market mitigation plan and currently have the values tabulated below.

Constant	Value
CTMG ₁	300%. The difference between offer and reference must be greater than 300% of the reference. (This is equivalent to saying that offer must be 400% of reference price or greater.)

CTMG ₂	\$100.00
-------------------	----------

6 Impact

6.1 Price Impact

The impact test compares prices (or local congestion) determined with two sets of offers: (i) an original set called the Base-Set and (ii) a set resulting from the mitigation of offers tripping the conduct test (subject to the arming criteria), called the Ref-Set. The price impact test is evaluated at each time interval. The test will trip for an interval if the difference in energy price (or local congestion) is significant. Ultimately a one-hour granularity, aligned with the one-hour offer periods, shall be used and the price impact shall trip for an entire hour if it trips for any interval during the hour.

6.1.1 NYCA Energy Price Impact

The same energy impact threshold is applied to NYCA super-zones DA and RT. The energy impact threshold is currently \$100. Currently the DA-AMP measures impacts on price of each zone in a super-zone. Zonal price is a weighted average of prices and the generators within a zone. The energy price impact test in RT-AMP is done at each generator in the super-zone and trips if the threshold is exceeded at any generator. The impact by super-zone is:

- West (zones A-E): If the change in LBMP at the location of any energy supplier in zones A-E exceeds the threshold for a 15-minute RTC interval then all energy resources in zones A-K are subject to mitigation for the hour containing the interval.
- East (zones F-I): If the change in LBMP at the location of any energy supplier in zones F-I exceeds the threshold for a 15-minute RTC interval then all energy resources in zones F-K are subject to mitigation for the hour containing the interval.
- NYC (zone J): If the change in LBMP at the location of any energy supplier in zone J exceeds the threshold for a 15-minute RTC interval then all energy resources in zone J are subject to mitigation for the hour containing the interval.
- LI (zone K): If the change in LBMP at the location of any energy supplier in zone K exceeds the threshold for a 15-minute RTC interval then all energy resources in zone K are subject to mitigation for the hour containing the interval.

6.1.2 Load Pocket Energy Price Impact

The load pocket impact test trips if the change in LBMP at the location of any energy supplier in a load pocket exceeds the threshold for that load pocket. In RT a load pocket is considered to have tripped the impact for the entire hour if it trips for any 15-minute interval in the hour. Separate load pocket thresholds are maintained for DA and RT. While the in-City DA-AMP and RT-AMP load pockets are calculated in the same manner, and should be quite close to each other, they probably will not be identical; the average price and the frequency of congestion, two components of the LPT formula, will differ as between DA and RT.

6.2 Guarantee Payment Impact

The Plan requires mitigation of offers for start-up cost, minimum generation cost, and incremental energy cost in the event that there is substantial impact on guarantee payments to the generator, even in the absence of an energy price impact. The guarantee payment is the difference between a supplier's cost and market revenue. However, the guarantee payment can be no less than zero. The DA-AMP accumulates guarantee payments for the full day to determined impact. The guarantee payment test for RT-AMP has no guarantee payment impact test will take place after the end of the operating day.

The impact test compares the guarantee payments associated with start-up, minimum generation, and energy ("guarantee payments") with two sets of offers and two sets of schedules. These are:

- An original set of offers, called the Base-Set
- A mitigated set of offers, called the Ref-Set
- The schedules and prices derived from Base-Set

- The schedules and prices derived from Ref-Set

Schedule & Price	From Base From Ref	Offer	
		Base	Ref
		GP ₁	GP ₂
GP ₃	GP ₄		

Guarantee payments shall be determined using original (base-set) and mitigated (ref-set) offers with schedules and prices from pass 1A (base-set results) and pass 1B (ref-set results). Referring to the table above, the four calculated guarantee payments use offer, price, and schedule as shown below:

Guarantee Payment	Offer	Price	Schedule
		(LBMP)	
GP ₁	Base	From Base	From Base
GP ₂	Ref	From Base	From Base
GP ₃	Base	From Ref	From Ref
GP ₄	Ref	From Ref	From Ref

Where total cost of an energy resource includes its start-up cost, minimum generation cost, and incremental energy cost. Revenue for the resource is its schedule times the clearing price for energy plus lost opportunity payments, if any. The guarantee payment impact for a generator is the ratio of the two guarantee payments for the time period. The impact test is said to have tripped for an hour, or remainder of an hour, if the ratio of guarantee payments exceeds the Plan's threshold. That is, the test trips if:

$$\frac{GP_1}{GP_2} \geq TGP, \text{ or}$$

$$\frac{GP_3}{GP_4} \geq TGP$$

Where:

Term	Description
TGP	Guarantee payment threshold

Provided that either GP₁ is greater than zero, or GP₃ is greater than zero, or both are greater than zero. The test trips if either GP₂ or GP₄ (or both) are equal to zero (that is, with mitigation there would be no guarantee payment).

7 Portfolio Exclusion

The portfolio exclusion of the DA-AMP (aka 50 MW exclusion) shall be modified to recognize the use of SU and/or MG to economically withhold resources. The entire capacity of a generating unit is considered withheld if the conduct test for SU is tripped or if the conduct test for MG is tripped. Otherwise, only the portion of the generating unit that trips the conduct test for incremental energy is considered withheld. Energy offers from generating units subject to the DA-AMP shall not be mitigated if the economic withholding of each organization that may influence that generating unit's offer is less than or equal to a predefined value, designated MW_{limit}. The value of MW_{limit} is currently 50 MW.

The RT-AMP has no portfolio exclusion.

8 Mitigation

8.1 Day-Ahead Mitigation Duration

8.1.1 NYCA Super-Zones

Given conduct and impact, the incremental energy offers will be mitigated in any hour that the super-zone trips the energy price impact test. The startup offer will be mitigated for all hours of the day if there is a price impact in any hour of the day. The minimum generation offer will be mitigated for each hour of the day that there is a price impact and for subsequent hours when the generator is within its minimum run time.

A generator that trips a guarantee payment impact test will have offers for incremental energy, startup, and minimum generation mitigated for each hour of the day with conduct.

8.1.2 Load Pockets

Within the NYC constrained area an energy resource may be associated with several load pockets, any of which may trip the impact test. To be mitigated for an hour a resource must be in at least one load pocket that trips the impact test for a time period during the hour. If a resource is in two or more load pockets that trip the impact test, the mitigated offer shall be prepared using the smallest of the load pockets' thresholds. The startup offer will be mitigated for all hours of the day if there is a price impact in any hour of the day. The minimum generation offer will be mitigated for each hour of the day that there is a price impact and for subsequent hours when the generator is within its minimum run time.

8.2 Real-Time Mitigation Duration

The tables below show duration of mitigation when a price impact is detected. Thus if a price impact is detected in both the current hour and the next hour (and offers in the next hour are locked) then units tripping the conduct test for energy, start-up, and/or minimum generation (in valid load pockets) will be mitigated for both hours.

Energy Price Impact		Mitigation					
Current Hour	Next Hour (offers locked)	Current Hour			Next Hour (offers locked)		
		E	SU	MG	E	SU	MG
Y	Y	Y	Y	Y	Y	Y	Y
Y	N	Y	Y	Y	N	N	N
N	Y	N	Y	Y	Y	Y	Y