



2021-2030

Comprehensive Reliability Plan

.....

A Report from the
New York Independent
System Operator

.....

Draft Report
For September 22, 2021 ESPWG/TPAS

Table of Contents

| | |
|--|-----------|
| EXECUTIVE SUMMARY..... | 9 |
| BACKGROUND..... | 10 |
| 2020 Reliability Needs Assessment..... | 10 |
| Short-Term Reliability Process..... | 12 |
| Post-RNA Updates..... | 12 |
| COMPREHENSIVE RELIABILITY PLAN FOR 2021-2030..... | 14 |
| Generation..... | 14 |
| Load..... | 14 |
| Transmission..... | 16 |
| Reliability Metrics..... | 17 |
| <i>Loss of Load Expectation.....</i> | <i>17</i> |
| <i>Zonal Resource Adequacy Margin (ZRAM).....</i> | <i>19</i> |
| <i>Binding Interfaces.....</i> | <i>20</i> |
| <i>Transmission Security Margins.....</i> | <i>22</i> |
| RISK FACTORS TO THE COMPREHENSIVE RELIABILITY PLAN..... | 27 |
| SAFEGUARDS TO THE COMPREHENSIVE RELIABILITY PLAN..... | 38 |
| BEYOND THE CRP – ROAD TO 2040..... | 42 |
| Load..... | 43 |
| Generation..... | 44 |
| <i>Intermittent Resources.....</i> | <i>46</i> |
| <i>Storage resources.....</i> | <i>50</i> |
| <i>Dispatchable Resources.....</i> | <i>51</i> |
| Transmission..... | 57 |
| MARKET DESIGN FOR A GRID IN TRANSITION..... | 61 |
| RECOMMENDED ACTIONS AND CONCLUSIONS..... | 63 |
| Monitor and Track Potential New Developments..... | 63 |
| Monitor and Track Transmission Owner Plans..... | 63 |
| Continue Coordination with the New York State Public Service Commission..... | 64 |
| Monitor Changes That Could Impact Risk Factors..... | 64 |
| Future NYISO studies..... | 65 |

| | |
|---|------------|
| APPENDIX A – GLOSSARY..... | 67 |
| APPENDIX B - PLANNED PROJECTS AND ASSUMPTIONS | 67 |
| APPENDIX C – RESOURCE ADEQUACY MODELS AND ANALYSIS | 104 |
| Modeling Background..... | 104 |
| Impacts of the Post-RNA (CRP) Changes..... | 105 |
| CRP Base Case Event Analysis..... | 113 |
| Resource Adequacy Assumptions Matrix | 117 |
| APPENDIX D – TRANSMISSION SECURITY MARGINS (“TIPPING POINTS”)..... | 124 |
| New York Control Area (NYCA) Tipping Points..... | 124 |
| Lower Hudson Valley (Zones G-J) Tipping Points..... | 128 |
| New York City (Zone J) Tipping Points..... | 135 |
| Long Island (Zone K) Tipping Points | 141 |
| APPENDIX E – 70 X 30 SCENARIO – EXTENDED WIND LULL | 146 |
| Summary of the 2020 RNA 70 x 30 Scenario Major Assumptions..... | 146 |
| Wind Lull Scenarios Assumptions | 148 |
| Wind Lull Scenario Scope..... | 153 |
| Wind Lull Scenario Results..... | 154 |
| <i>Loss of Land-Based Wind (LBW).....</i> | <i>155</i> |
| <i>Loss of Offshore Wind (OSW).....</i> | <i>158</i> |
| Wind Lull Conclusions..... | 162 |
| APPENDIX F – 70 X 30 SCENARIO – DYNAMIC STABILITY, SHORT-CIRCUIT RATIO, AND VOLTAGE FLICKER..... | 163 |
| Dynamic Stability | 163 |
| Summary of 2020 RNA Steady State Analysis Results from the 2020 RNA..... | 166 |
| 70 x 30 Dynamic Stability Transmission Security Methodology and Results..... | 166 |
| <i>N-1 Analysis.....</i> | <i>167</i> |
| <i>N-1-1 Analysis.....</i> | <i>167</i> |
| Sudden Loss of Offshore Wind..... | 170 |
| <i>N-1 & N-1-1 Analysis.....</i> | <i>170</i> |
| <i>N-1 & N-1-1 Analysis (Offshore Wind at Maximum Output).....</i> | <i>171</i> |
| <i>System Frequency Response for the Sudden Loss of Offshore Wind.....</i> | <i>172</i> |

| | |
|---|------------|
| Short-Circuit Ratio | 189 |
| <i>Background on Short-Circuit Ratio</i> | 189 |
| <i>NYCA Short-Circuit Ratio</i> | 190 |
| Voltage Flicker | 194 |
| APPENDIX G – RELIABILITY PLANNING PROCESS..... | 198 |
| APPENDIX H - RELIABILITY COMPLIANCE OBLIGATIONS AND ACTIVITIES | 205 |
| NPCC/NYSRC Area Transmission Reviews | 207 |
| NERC Planning Assessments (TPL-001)..... | 209 |
| Resource Adequacy Compliance Efforts..... | 211 |
| APPENDIX I - BULK POWER TRANSMISSION FACILITIES | 212 |

Table Of Figures

| | |
|--|----|
| Figure 1: Planned Additional Generating Resources (Nameplate MW)..... | 14 |
| Figure 2: Load and Generation Resources..... | 16 |
| Figure 3: LOLE, LOLH, and EUE Results..... | 19 |
| Figure 4: CRP Base Cases: Zonal Resource Adequacy Margin..... | 20 |
| Figure 5: Binding Interface Analysis..... | 21 |
| Figure 6: Zone J Summer Transmission Security Margin (Summer Baseline Peak Forecast - Normal)..... | 23 |
| Figure 7: Zone J Transmission Security Margins for Key Contingencies..... | 24 |
| Figure 8: NYCA Summer Transmission Security Margin (Summer Baseline Peak Forecast – Normal)..... | 26 |
| Figure 9: New York City Summer Transmission Security Margin (Summer Baseline Peak Forecast - Normal)..... | 28 |
| Figure 10: PSEG-Long Island Summer Transmission Security Margin (Summer Baseline Peak Forecast - Normal)..... | 30 |
| Figure 11: Lower Hudson Valley Summer Transmission Security Margin (Summer Baseline Peak Forecast - Normal)..... | 31 |
| Figure 12: Cumulative NYCA Nameplate Capacity MW Past the Age When 95% of Similar Units Have Retired..... | 33 |
| Figure 13: New York City Summer Transmission Security Margin..... | 36 |
| Figure 14: PSEG-Long Island Summer Transmission Security Margin (Summer Baseline Peak Forecast - Normal)..... | 36 |
| Figure 15: NYCA Summer Transmission Security Margin (Summer Baseline Peak Forecast - Normal)..... | 37 |
| Figure 16..... | 39 |
| Figure 17..... | 40 |
| Figure 18..... | 43 |
| Figure 19..... | 45 |
| Figure 20: Offshore Wind Lull for the Highest LOLE Week..... | 48 |
| Figure 21..... | 49 |
| Figure 22..... | 49 |
| Figure 23: 70 x 30 Short-Circuit Ratio (Peak Load)..... | 52 |
| Figure 24: 70 x 30 Peak Load Voltage Flicker..... | 54 |
| Figure 25: Maximum Hourly Ramping Requirement - Winter CLCPA Load Scenario, Baseline Case..... | 56 |
| Figure 26: Load and Capacity Data..... | 75 |
| Figure 27: Load and Capacity Year-by-Year MW..... | 76 |
| Figure 28: Baseline Peak Demand and Energy Forecasts..... | 77 |
| Figure 29: Planned Additions..... | 78 |
| Figure 30: Assumed Deactivations..... | 79 |
| Figure 31: Assumed Generation Status Change due to the DEC’s Peaker Rule..... | 79 |

| | |
|--|-----|
| Figure 32: Firm Transmission Plans included in 2020 RNA Base Case | 82 |
| Figure 33: Staten Island Dynamic Limits Changes..... | 105 |
| Figure 34: CRP Base Case, Study Year 2030, Bin and Month LOLE Distributions..... | 115 |
| Figure 35: CRP Base Case, Study Year 2030, Event Summary..... | 116 |
| Figure 36: CRP Base Case, Study Year 2030, LFU-Adjusted Load Shapes vs Load Events..... | 116 |
| Figure 37: NYCA Summer Transmission Security Margin (NYCA Summer Baseline Peak Forecast - Normal)..... | 125 |
| Figure 38: NYCA Summer Transmission Security Margin (NYCA 1-in-10 (90/10) Peak Forecast - Emergency) | 126 |
| Figure 39: NYCA Summer Transmission Security Margin (NYCA Summer 1-in-100 Peak Forecast - Emergency) | 127 |
| Figure 40: Summary of NYCA Transmission Security Margin..... | 128 |
| Figure 41: Lower Hudson Valley Summer Transmission Security Margin (Summer Baseline Peak Forecast - Normal)..... | 130 |
| Figure 42: G-J Summer Transmission Security Margin (Summer Baseline Peak Forecast - Normal)..... | 131 |
| Figure 43: G-J Summer Transmission Security Margin (Summer 1-in-10 (90/10) Peak Forecast - Emergency) | 132 |
| Figure 44: G-J Summer Transmission Security Margin (Summer 1-in-100 Peak Forecast - Emergency)..... | 133 |
| Figure 45: Summary of Lower Hudson Valley Summer Transmission Security Margin | 134 |
| Figure 46: Impact of Contingency Combination on Zone J Transmission Security Margin..... | 136 |
| Figure 47: Zone J Summer Transmission Security Margin (Summer Baseline Peak Forecast - Normal)..... | 137 |
| Figure 48: Zone J Transmission Security Margin (Summer 1-in-10 (90/10) Peak Forecast - Emergency) | 138 |
| Figure 49: Zone J Transmission Security Margin (Summer 1-in-100 Peak Forecast - Emergency)..... | 139 |
| Figure 50: Summary of Zone J Transmission Security Margin | 140 |
| Figure 51: Impact of Contingency Combination on Zone K Transmission Security Margin..... | 141 |
| Figure 52: Zone K Summer Transmission Security Margin (Summer Baseline Peak Forecast - Normal)..... | 142 |
| Figure 53: Zone K Summer Transmission Security Margin (Summer 1-in-10 (90/10) Peak Forecast - Emergency) | 143 |
| Figure 54: Zone K Transmission Security Margin (Summer 1-in-100 Peak Forecast - Emergency)..... | 144 |
| Figure 55: Summary of Zone K Transmission Security Margin..... | 145 |
| Figure 56: Renewable Mix Assumptions for each Load Level..... | 147 |
| Figure 57: Summer Energy and Peak Demand Forecast Zonal Distribution | 147 |
| Figure 58: “70 x 30 Base Load” Case at-Criterion: Age-based Fossil Removal..... | 149 |
| Figure 59: “70 x 30 Base Load” Case: ICAP vs UCAP..... | 150 |
| Figure 60: “7070 x 30 Scenario Load” Case at-Criterion: Age-based Fossil Removal..... | 152 |
| Figure 61: “70 x 30 Scenario Load” Case at-Criterion: ICAP vs UCAP..... | 152 |
| Figure 62: NYCA LOLE (days/year) for Loss of LBW during the Week with Highest LOLE Events..... | 155 |
| Figure 63: NYCA LOLE (days/year) for Loss of LBW during the Week with Highest LBW Capacity Factor | 156 |
| Figure 64: NYCA LOLE (days/year), LOLH (hours/year) and EUE (MWh/year) for Loss of LBW during the Week with Highest LOLE Events..... | 157 |

| | |
|---|-----|
| Figure 65: NYCA LOLE (days/year), LOLH (hours/year) and EUE (MWh/year) for Loss of LBW during the Week with Highest LBW Capacity Factor | 157 |
| Figure 66: NYCA LOLE (days/year) for Loss of OSW during the Week with Highest LOLE Events..... | 158 |
| Figure 67: NYCA LOLE (days/year) for Loss of OSW during the Week with Highest OSW Wind Capacity Factor | 158 |
| Figure 68: OSW MW Output during the Week with Highest OSW Capacity Factor | 159 |
| Figure 69: OSW MW Output during the Week with Highest % Events for the 70 x 30 ‘Base Load’ Cases..... | 159 |
| Figure 70: OSW MW Output during the Week with Highest % Events – 70 x 30 ‘Scenario Load’ and ‘Low LOLE’ Cases | 160 |
| Figure 71: NYCA LOLE (days/year), LOLH (hours/year) and EUE (MWh/year) for Loss of OSW during the Week with Highest LOLE Events..... | 160 |
| Figure 72: NYCA LOLE (days/year), LOLE (days/year), LOLH (hours/year) and EUE (MWh/year) for Loss of OSW during the Week with Highest OSW Wind Capacity Factor..... | 161 |
| Figure 73: 70 x 30 Scenario Transmission Security Case Assumptions (‘Base Load’ Case) | 165 |
| Figure 74: Capabilities (MW) of Renewable Mix Assumptions for Base Load..... | 165 |
| Figure 75: First Level Outage Cases for N-1-1 Analysis..... | 168 |
| Figure 76: N-1-1 Second Level Contingencies..... | 169 |
| Figure 77: Light Load Interface Flows for the Loss of Offshore Wind (Base Output)..... | 171 |
| Figure 78: Light Load interface Flows for the Loss of Offshore Wind (Maximum Output)..... | 172 |
| Figure 79: Frequency Response Characteristics..... | 173 |
| Figure 80: Typical Inertia Constant (H) Range | 174 |
| Figure 81: Effect of Primary Frequency Response on System Frequency..... | 176 |
| Figure 82: Simultaneous Contributions of Inertia Response, FFR, and PFR ⁶⁸ | 177 |
| Figure 83: FFR Response from Inverter Based Resources ⁶⁸ | 178 |
| Figure 84: System Frequency Response and NYCA Generation Response for the Loss of Offshore Wind - Case 1 | 180 |
| Figure 85: Summary of System Frequency Response Characteristics - Case 1..... | 180 |
| Figure 86: System Frequency Response and NYCA Generation Response for the Loss of Off-Shore Wind - Case 3..... | 181 |
| Figure 87: Summary of System Frequency Response Characteristics - Case 3..... | 182 |
| Figure 88: System Frequency Response and NYCA Generation Response | 183 |
| Figure 89: Summary of Frequency Response Characteristics - Case 6..... | 183 |
| Figure 90: Case 3 (Light Load) System Frequency Response (Including External Area) with Y49 Out-of-Service | 184 |
| Figure 91: System Frequency Response with External Area Inertia Constant (H) Reduced by Approx. 50%..... | 186 |
| Figure 92: Summary of System Frequency Response Characteristics - With H Reduced by Approx. 50% in External Areas.. | 186 |
| Figure 93: System Frequency Response Characteristic with External Area Inertia Constant (H) Reduced by 50% and Increased Governor Squelching..... | 188 |

| | |
|---|-----|
| Figure 94: Summary of Frequency Response Characteristics - With H Reduced by Approx. 50% and Increased Governor Squelching..... | 189 |
| Figure 95: NYCA Buses with Short-Circuit Ratio Less than 3.0..... | 191 |
| Figure 96: Case 1 Short-Circuit Ratio Locations..... | 191 |
| Figure 97: NYCA Buses with Weighted Short-Circuit Ratio Less than 3.0..... | 192 |
| Figure 98: Case 1 Weighted Short-Circuit Ratio Locations..... | 193 |
| Figure 99: Summary of NYCA Flicker..... | 195 |
| Figure 100: Peak Load Flicker..... | 195 |
| Figure 101: Light Load Flicker..... | 196 |
| Figure 102: Shoulder Load Flicker..... | 196 |
| Figure 103: NYISO’s Comprehensive System Planning Process (CSPP)..... | 203 |
| Figure 104: NYISO Reliability Planning Process..... | 204 |
| Figure 105: List of NERC Standards for Planning Coordinators and Transmission Planners..... | 206 |
| Figure 106: Description of NERC TPL-001 Planning Assessment Study Cases..... | 210 |

Executive Summary

[to be written]

Background

The 2020 Reliability Needs Assessment (RNA) was the first step of the NYISO's 2020-2021 Reliability Planning Process. The 2020 RNA was approved by the NYISO Board of Directors in November 2020 [\[link\]](#). This 2021-2030 Comprehensive Reliability Plan (CRP) follows the 2020 RNA and post-RNA updates and completes the 2020-2021 cycle of the Reliability Planning Process. This CRP also incorporates findings and solutions from the quarterly Short-Term Reliability Process.

2020 Reliability Needs Assessment

The 2020 RNA provided an evaluation and review of the reliability of the New York Bulk Power Transmission Facilities (BPTF) for the Study Period (2024-2030), considering forecasts of peak power demand, planned upgrades to the transmission system, and changes to the generation mix expected over the next ten years (2021-2030). The RNA assessed an actionable "base case" set of assumptions, as well as various scenarios that are provided for information. The 2020 RNA base case included projected impacts driven by limitations on generator emissions, while the scenarios included an in-depth look at certain policy goals from the Climate Leadership and Community Protection Act (CLCPA). The RNA also discussed the reliability risks associated with the cumulative impact of environmental laws and regulations, which may affect the availability and flexibility of power plant operation.

The 2020 RNA identified violations or potential violations of reliability criteria ~~("Reliability Needs")~~ in the actionable base case throughout the entire study period (2024-2030) due to dynamic instability, transmission overloads, and/or resource deficiencies.¹ The issues identified were primarily driven by a combination of forecasted peak demand and the assumed unavailability of certain generation in New York City affected by the "Peaker Rule."

In 2019, the New York State Department of Environmental Conservation adopted a regulation to limit nitrogen oxides (NOx) emissions from simple-cycle combustion turbines (referred to as the "Peaker Rule²"). Combustion turbines known as "peakers" typically operate to maintain bulk power system reliability during the most stressful operating conditions, such as periods of peak electricity demand. Many of these units also maintain transmission security by supplying energy within certain constrained areas of New York City and Long Island — known as load pockets³. The Peaker Rule, which phases in compliance obligations between 2023 and 2025, will impact turbines located mainly in the lower Hudson Valley, New

¹ Effective May 1, 2020, the scope of the RNA is limited to years 4-10 of the planning horizon while the NYISO Short-Term Reliability Process is responsible for years 1-3 and also assesses years 4-5.

² <https://www.dec.ny.gov/regulations/116131.html>

³ [The Con Edison criteria reference Transmission Load Areas, which are analogous to load pockets.](#)

York City, and Long Island. The Peaker Rule required all impacted plant owners to file compliance plans by March 2, 2020. The plans filed in 2020 indicate approximately 1,500 MW of peaker capability would be unavailable during the summer by 2025 to comply with the emissions requirements. A subset of those generators would be unavailable starting in 2023.

The 2020 RNA also discussed the coronavirus outbreak and its significant impact on New York's economy due to reductions in commercial and industrial activity as New Yorkers adjusted their lives by working from home and limiting social interaction. Due to the rapidly evolving nature of the pandemic, the demand forecasts utilized in the study reflected the NYISO's perspective as of April 2020. The sudden departure from historical behavioral patterns caused by New York's response to COVID-19 is unprecedented and creates unique challenges to forecasting the state's energy needs. As the situation evolves and more data becomes available, the NYISO will continue to monitor these forecasts and adjust course accordingly. As further described in the "Next Steps" section of the 2020 RNA, and also below, following approval of the RNA by the Board and prior to any solicitation of solutions, the NYISO considered updates to the peak load forecasts and determined to what extent the forecasts impacted any identified system needs.

A summary of the 2020 RNA Base Case findings are below:

- Dynamic stability Reliability Needs were observed for the entire Study Period. Following the initial phase of the Peaker Rule in 2023, instability of the grid may have occurred due to a lack of dynamic reactive power capability and inertia available to parts of the New York City grid. The criteria violations included transient voltage response violations, loss of generator synchronism, and undamped voltage oscillations.
- With full implementation of the Peaker Rule in 2025, several 345 kV circuits in the Con Edison service territory would have been overloaded, resulting in Reliability Needs equating to a deficiency of 700 MW and increasing to 1,075 MW by 2030. The duration of the deficiency ranges from nine hours in 2025 (3,853 MWh) to 12 hours in 2030 (7,672 MWh).
- Similar transmission deficiencies would have also occurred within pockets of Con Edison's non-bulk system (138 kV) ranging in duration from 10 to 14 hours.
- The studied system exceeded the LOLE criterion of one day in 10 years, or 0.1 days per year, starting in 2027, and increasing through 2030 resulting in a Reliability Need with a compensatory MW amount of 350 MW in 2030.

Short-Term Reliability Process

In parallel with the RNA and CRP process, the NYISO has implemented a new quarterly Short-Term Reliability Process (“STRP”), with its requirements prescribed in Attachments Y and FF of the NYISO’s Open Access Transmission Tariff. The STRP evaluates the first five years of the planning horizon, with a focus on needs arising in the first three years of the study period. With this process in place, the biennial Reliability Planning Process focuses on solutions to longer term needs through the Reliability Needs Assessment (“RNA”) and the Comprehensive Reliability Plan (“CRP”).

The first step in the STRP is the Short-Term Assessment of Reliability (“STAR”). STARS are performed quarterly to proactively address reliability needs that may arise within five years (“Short-Term Reliability Needs”)⁴ due to various changes to the grid such as generator deactivations, revised transmission plans, and updated load forecasts. Transmission Owners (“TO”) also assess the impact of generator deactivations on their local systems. A Short-Term Reliability Need that is observed within the first three years of the study period constitutes a “Near-Term Reliability Need.”⁵ Should a Near-Term Reliability Need be identified in a STAR, the NYISO solicits and selects the solution to address the need. If a need arises beyond the first three years of the study period, the NYISO may choose to address the need within the STRP or, if time permits, through the long-term Reliability Planning Process.

The 2020 Quarter 3 STAR⁶ found Short-Term Reliability Needs on the Bulk Power Transmission Facilities (“BPTF”) starting in 2023 and increasing in scope and scale through 2025. Through the STRP, the NYISO addressed the Near-Term Reliability Needs arising in 2023, with the needs arising in 2024 and 2025 being addressed through the Reliability Planning Process. On December 3, 2020, the NYISO issued a solution solicitation requesting the submission of proposed STRP Solutions to address the 2023 needs.

Post-RNA Updates

After the 2020 RNA was approved and before a solicitation for solutions, the process considered subsequent base case updates that met the inclusion rules. The following updates were made:

- NYISO’s load forecast update to account for the expected impact of COVID-19 and the associated economic and societal effects, as presented at the November 19, 2020 ESPWG/TPAS/LFTF meeting [\[link\]](#)
 - For example, the Zone J peak load forecast decreased by 392 MW in 2030
- Local Transmission Owner Plans (LTPs) updates [to address local reliability deficiencies](#) as

⁴ OATT Section 38.1 contains the tariff definition of a “Short-Term Reliability Process Need.”

⁵ OATT Section 38.1 contains the tariff definition of a “Near-Term Reliability Need.” See also, OATT Section 38.3.6.

⁶ <https://www.nyiso.com/documents/20142/16004172/2020-Q3-STAR-Report-vFinal.pdf/>

presented by Con Edison at the January 25, 2021 ESPWG/TPAS [link]:

- A new 345/138 kV PAR controlled 138 kV Rainey – Corona feeder (ISD 2023)
 - A new 345/138 kV PAR controlled 138 kV Gowanus – Greenwood feeder (ISD 2025)
 - A new 345/138 kV PAR controlled 138 kV Goethals – Fox Hills feeder (ISD 2025)
- Short Term Reliability Process solution for addressing the 2023 short-term need identified in the Q3 STAR [link]. The solution changed the planned operating status of existing series reactors, starting summer 2023 through 2030:
 - In-service: series reactors on the following 345 kV cables: 71, 72, M51, M52
 - Bypass: series reactors on the following 345 kV cables⁷: 41, 42, Y49
 - The transient voltage response issues were observed on Con Edison’s non-BPTF system during 2025 through 2030, while the BPTF violations were observed starting in 2029. Con Edison will address the non-BPTF violations with a Corrective Action Plan as required by NERC Standard TPL-001-4. When the non-BPTF violations are addressed, the BPTF violations are no longer observed.[link]

With these base case updates, there is no remaining Reliability Need throughout the 2024-2030 RNA study period, and the NYISO will not solicit solutions in the 2020-2021 cycle of the Reliability Planning Process. Additionally, besides the 2020 Quarter 3 STAR, no other reliability needs have been identified and addressed in the STARS completed to date.

⁷ Additional LTPs were subsequently presented by the Transmission Owners, such as further changing the status of the series reactors on Con Edison’s cables #41 and #42 from assumed bypassed in this CRP (starting 2023) to in-service, starting summer 2025 – details in the July 23, 2021 ESPWG Con Edison’s presentation [link]. This change is reflected in the 2021 Q3 STAR models, which targets October 13, 2021 for completion and posting.

Comprehensive Reliability Plan for 2021-2030

The Comprehensive Reliability Plan to reliably serve New York demand for the 2021-2030 timeframe incorporates forecasting the balance between generation, load, and transmission. A key part of the reliability process is to apply conservative inclusion rules so that only those projects that have a high level of certainty of being completed are planned for. This often results in only limited amounts of generation and transmission projects being included in the base case. The following section summarizes the key future projects and assumptions that have been included as part of the Comprehensive Reliability Plan, and the resultant reliability metrics for the system as planned.

Generation

Figure 1 shows the planned additional generation resources included as part of the CRP. These resources include a total of 546.4 MW of land-based wind generation and 22.9 MW of solar generation planned to be in-service by summer 2022, with an additional 100 MW of land-based wind generation by summer 2023.

Figure 1: Planned Additional Generating Resources (Nameplate MW)

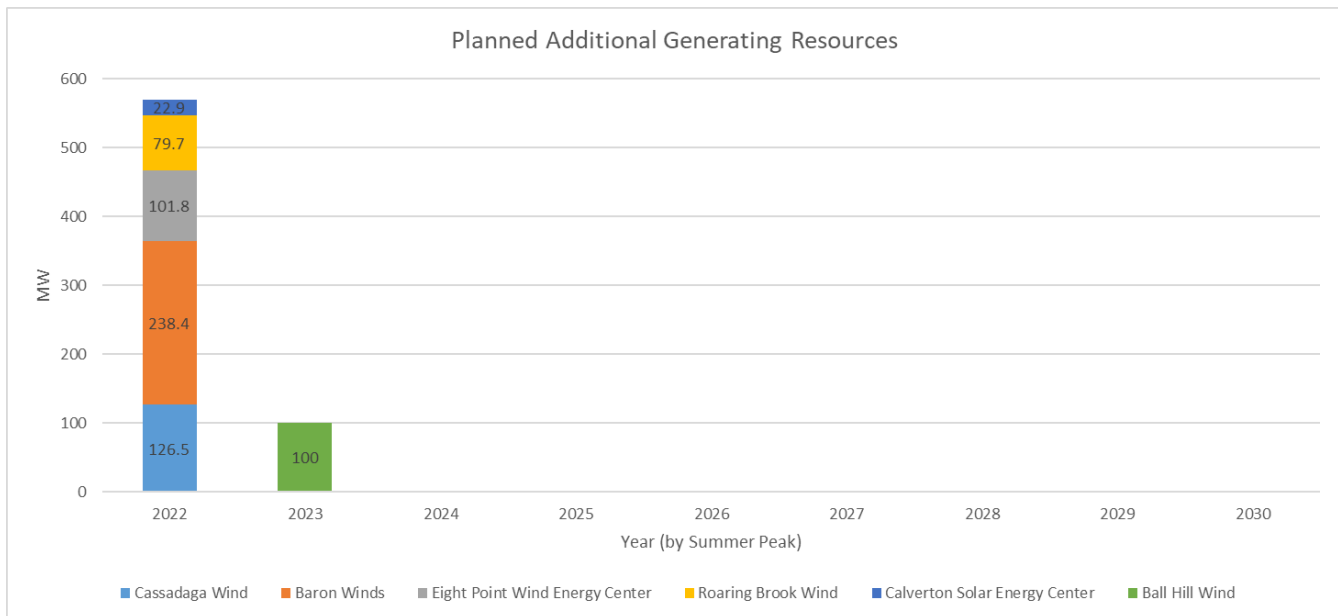

Load

The 2020 Load and Capacity Data Report (“Gold Book”) provides an in-depth review of the load forecast and changing resource mix. In general, the baseline forecast published in the 2021 Gold Book is lower than the level published in the 2020 Gold Book. The lower forecasted growth in energy usage can be

attributed primarily to increased projected load reductions due to energy efficiency programs, increased load reductions due to stronger projected growth in behind-the-meter solar PV, and continuing economic impacts caused by the recession brought on by the COVID-19 pandemic. **Figure 2** shows the forecasted NYCA load under baseline conditions as well as 90th (1-in-10 or 90/10) and 1-in-100 peak forecasts due to weather variations. The changing resource mix shown in **Figure XX** includes the new generating resources (shown in **Figure XX**) as well as other planned generation removals.

Figure 2: Load and Generation Resources⁸

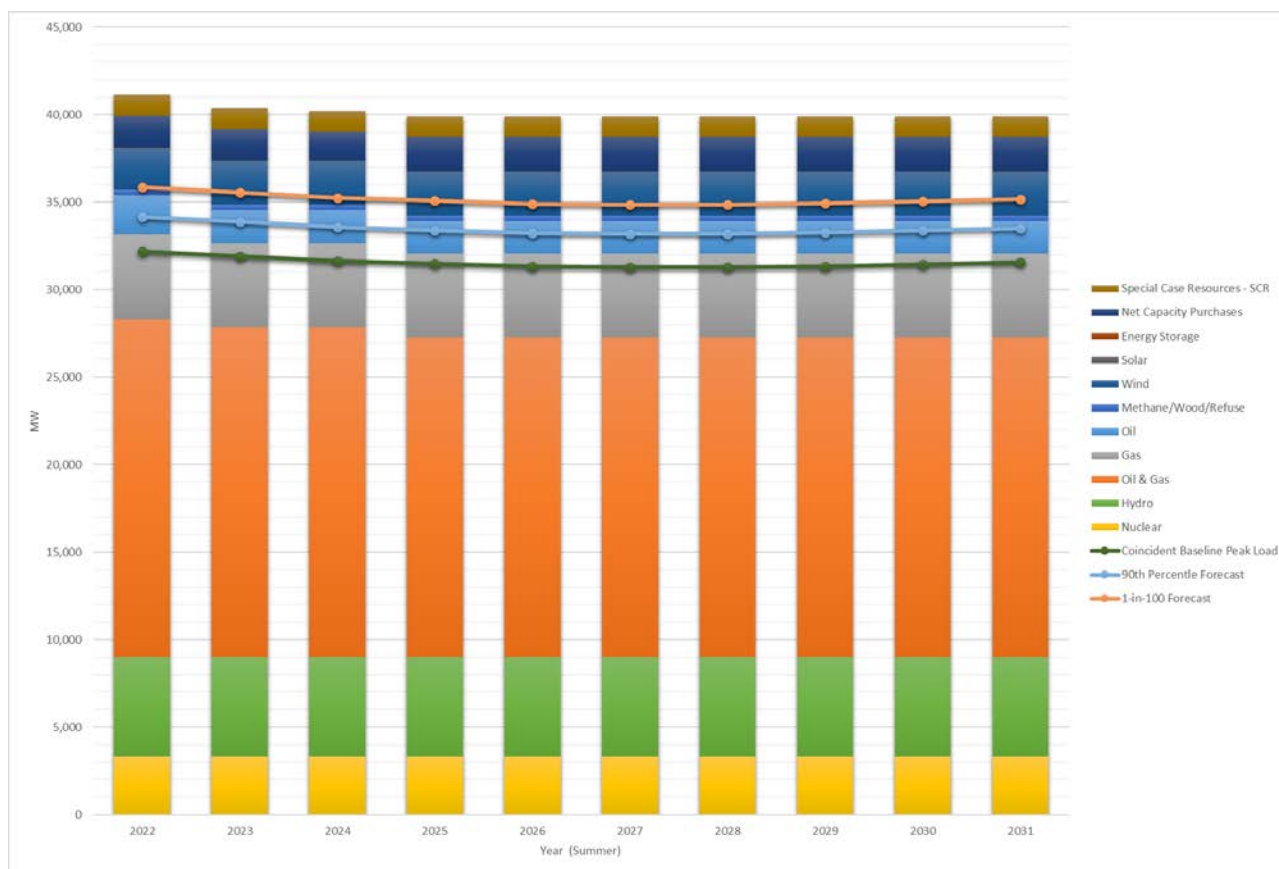

Transmission

Planned additions to the New York transmission system include the following:

- June 2022: The NextEra Empire State Line Project that was selected by the NYISO Board of Directors in October 2017 to address the Western New York Public Policy Transmission Need.
- December 2023: The Segment A, AC Transmission joint project, by LS Power and New York Power Authority (NYPA) that was selected by the NYISO Board of Directors in April 2019.
- December 2023: The New York Transco Segment B, AC Transmission project, also was selected by the NYISO Board of Directors in April 2019.

⁸ Generation resources are from the summer capability listed in the 2021 Load and Capacity Data Report ([Gold Book](#)) and do not reflect the capabilities utilized in the resource adequacy analysis.

- Transmission Owner Local Transmission Plans (LTP) that meet the Inclusion Rules which includes:
 - Summer 2021: National Grid Clay #3 115 kV line uprate [\(in service\)](#)
 - Summer 2021: National Grid Clay #10 115 kV line uprate [\(in service\)](#)
 - Summer 2023: Orange & Rockland Lovett 345/138 kV substation.
 - Summer 2023: Con Edison new 345/138 kV PAR controlled 138 kV Rainey – Corona feeder
 - Summer 2025: Con Edison new 345/138 kV PAR controlled 138 kV Gowanus – Greenwood feeder
 - Summer 2025: Con Edison new 345/138 kV PAR controlled 138 kV Goethals – Fox Hills feeder
- In-service, starting summer 2025: series reactors on the following Con Edison 345 kV cables: 71, 72, M51, M52.
- Bypass, starting summer 2025: series reactors on the following Con Edison 345 kV cables: 41, 42, Y49.

[It is important to note that the NYISO Interconnection Queue contains an unprecedented number of proposed projects in various stages of development. The NYISO's Gold Book Tables IV and VII contain proposed generation and transmission projects that are in a more advanced stages of the interconnection process, of which only a few passed the reliability planning inclusion rules for this CRP.](#)

Reliability Metrics

With the CRP base case assumptions described above, and in the Appendix **xx**, the system as planned meets all applicable reliability criteria for the entire study period. The NYISO will continue to evaluate whether Reliability Needs arise in subsequent biennial cycles of the Reliability Planning Process, as well as in the quarterly Short Term Reliability Process (STRP).

Loss of Load Expectation

The NYCA loss of load expectation (LOLE in days/year) results are provided in **Figure 3**. For reference, the previous results from the 2020 RNA are provided along with the current results for this 2021-2030 CRP. LOLE accounts for events but does not account for the magnitude (MW) or duration

(hours) of the deficit. Therefore, two additional reliability indices are added for information purposes: loss of load hours (LOLH in hours/year), and expected unserved energy (EUE in MWh/year).

LOLE is generally defined as the expected (weighted average) number of days in a given period (*e.g.*, one study year) when for at least one hour from that day, the hourly demand is projected to exceed the zonal resources (event day). Within a day, if the zonal demand exceeds the resources in at least one hour of that day, this will be counted as one event day. The criterion is that the LOLE not exceed one day in 10 years, or $LOLE < 0.1$ days/year.

LOLH is generally defined⁹ as the expected number of hours per period (*e.g.*, one study year) when a system's hourly demand is projected to exceed the zonal resources (event hour). Within an hour, if the zonal demand exceeds the resources, this will be counted as one event hour.

EUE, also referred to as loss of energy expectation (LOEE), is generally defined¹⁰ as the expected energy (MWh) per period (*e.g.*, one study year) when the summation of the system's hourly demand is projected to exceed the zonal resources. Within an hour, if the zonal demand exceeds the resources, this deficit will be counted toward the system's EUE.

While the resource adequacy reliability criterion of 0.1 days/year established by the NYSRC and the NPCC is compared with the loss of load expectation (LOLE in days/year) calculation, currently there is no criteria for determining a reliable system based on the LOLH and EUE reliability indices.

⁹ NYSRC's "Resource Adequacy Metrics and their Application":
[https://www.nysrc.org/PDF/Reports/Resource%20Adequacy%20Metric%20Report%20Final%204-20-2020\[6431\].pdf](https://www.nysrc.org/PDF/Reports/Resource%20Adequacy%20Metric%20Report%20Final%204-20-2020[6431].pdf)

¹⁰ NYSRC's "Resource Adequacy Metrics and their Application":
[https://www.nysrc.org/PDF/Reports/Resource%20Adequacy%20Metric%20Report%20Final%204-20-2020\[6431\].pdf](https://www.nysrc.org/PDF/Reports/Resource%20Adequacy%20Metric%20Report%20Final%204-20-2020[6431].pdf)

Figure 3: LOLE, LOLH, and EUE Results

| 2020 RNA Base Case | | | | 2021-2030 CRP Base Case | | | |
|--------------------|--------------|--------------|--------------|-------------------------|--------------|--------------|--------------|
| Study Year | LOLE (dy/yr) | LOLH (hr/yr) | EUE (MWh/yr) | Study Year | LOLE (dy/yr) | LOLH (hr/yr) | EUE (MWh/yr) |
| 2021 | 0.017 | 0.063 | 34.0 | 2021 | 0.017 | 0.064 | 35.3 |
| 2022 | 0.019 | 0.061 | 28.7 | 2022 | 0.017 | 0.055 | 26.6 |
| 2023 | 0.041 | 0.125 | 61.6 | 2023 | 0.034 | 0.106 | 50.8 |
| 2024 | 0.038 | 0.125 | 69.3 | 2024 | 0.024 | 0.083 | 47.2 |
| 2025 | 0.085 | 0.265 | 138.3 | 2025 | 0.036 | 0.118 | 69.3 |
| 2026 | 0.097 | 0.315 | 178.3 | 2026 | 0.038 | 0.131 | 83.7 |
| 2027 | 0.118 | 0.379 | 208.6 | 2027 | 0.040 | 0.139 | 93.2 |
| 2028 | 0.135 | 0.421 | 215.4 | 2028 | 0.047 | 0.146 | 83.4 |
| 2029 | 0.170 | 0.548 | 308.2 | 2029 | 0.060 | 0.199 | 137.2 |
| 2030 | 0.187 | 0.609 | 354.1 | 2030 | 0.064 | 0.212 | 156.2 |

Zonal Resource Adequacy Margin (ZRAM)

Resource adequacy simulations were performed [on the CRP base cases¹¹](#) to determine the amount of “perfect” capacity in each zone that could be removed before the NYCA LOLE reaches 0.1 days/year (“one-event-day-in-ten-years”), and to offer another relative measure of how close the system is from not having adequate resources to reliably serve load. This analysis found tightening margins across the New York grid through time, with a margin of only 200 MW in New York City (Zone J) by 2030.

Resource capacity is reduced one zone at a time to determine when violations occur, in the same manner as the compensatory “perfect” MW are added to mitigate resource adequacy violations, but with the opposite impact. “Perfect capacity” is capacity that is not derated (*e.g.*, due to ambient temperature or unit unavailability), not subject to energy durations limitations (*i.e.*, available at maximum capacity every hour of the study year), and not tested for transmission security or interface impacts. The zonal resource margin analysis is summarized in **Figure 4**.

¹¹ [The CRP base cases already reflect the DEC Peaker Rule compliance plans submitted by the affected generation owners to DEC; summarized in the assumptions tables from Appendix B of this report.](#)

Figure 4: CRP Base Cases: Zonal Resource Adequacy Margin

| Study Year | LOLE | Zone A | Zone B | Zone C | Zone D | Zone E | Zone F | Zone G | Zone H | Zone I | Zone J | Zone K |
|------------|------|--------|--------|--------|--------|--------|--------|--------|--------|--------|--------|--------|
| 2024 | 0.02 | -950 | EZR | -1850 | -1800 | EZR | -1850 | -1850 | EZR | EZR | -750 | -1350 |
| 2025 | 0.04 | -1000 | EZR | -1550 | -1550 | EZR | -1550 | -1550 | EZR | EZR | -500 | -1200 |
| 2026 | 0.04 | -950 | EZR | -1500 | -1500 | EZR | -1450 | -1500 | EZR | EZR | -500 | -1250 |
| 2027 | 0.04 | -850 | EZR | -1400 | -1400 | EZR | -1400 | -1400 | EZR | EZR | -400 | -1250 |
| 2028 | 0.05 | -900 | EZR | -1300 | -1250 | EZR | -1300 | -1300 | EZR | EZR | -350 | -1150 |
| 2029 | 0.06 | -750 | -750 | -950 | -950 | -950 | -950 | -950 | EZR | EZR | -250 | -1000 |
| 2030 | 0.06 | -700 | -700 | -800 | -800 | -800 | -800 | -800 | EZR | EZR | -200 | -850 |

Notes:

- Negative numbers indicate the amount of “perfect MW” that can be removed from a zone without causing a violation.
- EZR - ~~exceeds zonal resources~~ **Exceeds Zonal Resources** (all generation can be removed without causing a violation).
- The generation pockets in Zone J and Zone K are not modeled in detail in MARS and the margins identified here may be smaller as a result.

The ZRAM assessment identifies a maximum level of “perfect capacity” that can be removed from each zone without causing NYCA LOLE criterion violations. However, the impacts of removing capacity on the reliability of the transmission system and on transfer capability are highly location dependent. Thus, in reality, lower amounts of capacity removal are likely to result in reliability issues at specific transmission locations. With these simulations, the NYISO did not attempt to assess a comprehensive set of potential scenarios that might arise from specific unit retirements. Therefore, actual proposed capacity removal from any of these zones would need to be further studied in light of the specific capacity locations in the transmission network to determine whether any additional violations of reliability criteria would result. Additional transmission security analysis, such as N-1-1 steady-state analysis, transient stability, and short circuit, would be necessary under the applicable process for any contemplated plant retirement in any zone.

Binding Interfaces

To determine whether or not a specific transmission interface impacts system resource adequacy, ‘free-flow’ simulations were performed for targeted interfaces. This is implemented in resource adequacy models by removing the limit on various transmission interfaces, either one at the time, or in various combinations (*i.e.* “free flow”). A decrease in the NYCA LOLE resulting from removal of an interface limit is an indication that the flow of power across the interface is “binding” due to transmission constraints. The results of these simulations are shown in **Figure ##. Figure 5.**

Figure 5: Binding Interface Analysis

| Study Year | 2021-2030 CRP Base Case NYCA LOLE (days/year) | | | | |
|------------|--|---|---|-----------------------------------|----------------------------------|
| | Base Case | Unlimited I-to-J (Dunwoodie South) | Unlimited G-to-H (UPNY- ConEd) | Unlimited G-to-H and I-to-J | Unlimited NYCA 'Free Flow' |
| 2024 | 0.024 | 0.021 | 0.024 | 0.021 | 0.019 |
| 2025 | 0.036 | 0.027 | 0.035 | 0.025 | 0.022 |
| 2026 | 0.038 | 0.029 | 0.038 | 0.028 | 0.023 |
| 2027 | 0.040 | 0.028 | 0.039 | 0.026 | 0.021 |
| 2028 | 0.047 | 0.034 | 0.046 | 0.030 | 0.025 |
| 2029 | 0.060 | 0.043 | 0.059 | 0.037 | 0.029 |
| 2030 | 0.064 | 0.045 | 0.063 | 0.035 | 0.028 |

The results show that:

- The system resource adequacy improves when the Dunwoodie South interface constraints (Zone I to Zone J) are alleviated, which is an indication that the transmission interface is “binding.” In other words, if the Dunwoodie South interface limits increase due to a system change such as a transmission upgrade, grid resource adequacy would improve. The extent of improvement to resource adequacy would depend on the nature of the system change.
- The grid resource adequacy is not materially impacted by the UPNY-ConEd constraints (Zone G to Zone H), due to the fact that most of the loss-of-load events are in Zone J, and the Dunwoodie South interface ‘binds’ first. Therefore, an upgrade to only UPNY-ConEd and not Dunwoodie South would not provide a material resource adequacy benefit.
- When both the Dunwoodie South and UPNY-ConEd interface constraints are alleviated together, grid resource adequacy is improved more so than if Dunwoodie South alone is upgraded.
- The difference in LOLE between the “NYCA free flow” case and the case when Dunwoodie South and UPNY-ConEd are unlimited is only approximately 0.005, which indicates that there is almost no further resource adequacy improvement that would be achieved from increasing additional interface limits for the planned base case conditions.

Transmission Security Margins

With the CRP base case assumptions, all dynamic stability and steady state thermal loading criteria violations previously identified in the 2020 RNA are resolved. The NYISO will continue to evaluate whether Reliability Needs arise in subsequent cycles of the biennial Reliability Planning Process, as well as in the quarterly Short Term Reliability Process (STRP).

The impacts of the updates on transmission security are described below.

- The first update involved the reduction of the load forecast to account for the expected impact of COVID-19 and associated economic and societal effects. The total NYCA reduction in forecast for the summer 2025 peak load is 240 MW, and for the 2030 peak load the reduction is 383 MW. Specifically, the Zone J peak load forecast decreased by 323 MW in 2025 and 392 MW in 2030. This decreases the thermal load and transient voltage response issues.
- The second update involved the Con Edison Local Transmission Plan (LTP) updates. Con Edison updated their Local Transmission Plan (LTP) to address local non-BPTF thermal deficiencies in their Astoria East/Corona 138 kV Transmission Load Area (TLA) and Greenwood/Fox Hills 138 kV TLA. The Con Edison LTP update included three new 345/138 kV PAR-controlled 138 kV feeders at Rainey – Corona, Gowanus – Greenwood, and Goethals – Fox Hills. The impacts of these projects is to reduce the transient voltage response issue, as well as the Goethals – Fox Hill feeder unbottling Staten Island resources.
- The third update was the Con Edison series reactor status change that balanced the flows on the BPTF and also resulted in a reduction of the transient voltage response issue.

Including these projects resulted in the CRP (or “post-RNA”) base case showing a transmission security margin of 50 MW in Zone J in 2030 before thermal overloads may occur.¹² Due to the narrow margin, it is plausible for changes in these conditions or assumptions to “tip” the system into a violation of transmission security design criteria.

Within the Con Edison service territory, the 345 kV transmission system along with specific portions of the 138 kV transmission system are designed for the occurrence of two non-simultaneous contingencies and a return to normal ratings (N-1-1-0).¹³ **Figure 6** provides a summary of the Zone J transmission security margin. The tipping point occurs when the transmission security margin is a negative value. Details of the tipping point evaluations are provided in **Appendix XX**.

The tipping points for Zone J are evaluated under the most limiting N-1-1-0 contingency combination to the transmission security margin, which is loss of Ravenswood 3 followed by the loss of Mott Haven – Rainey 345 kV (Q12). **Figure 6** shows the transmission security margin (line_item M) under baseline load

¹² https://www.nyiso.com/documents/20142/19415353/07-2020-2021RPP_PostRNABaseCaseUpdates.pdf/
https://www.nyiso.com/documents/20142/19415353/07-2020-2021RPP_PostRNABaseCaseUpdates.pdf/

¹³ Con Edison, [TP-7100-18 Transmission Planning Criteria](#), dated August 2019

conditions with this contingency combination, which ranges from 1,714 MW in 2022 to 42 MW in 2031.

Figure 6: Zone J Summer Transmission Security Margin (Summer Baseline Peak Forecast - Normal)

| Line | Item | Peak Load Forecast | | | | | | | | | |
|------|--|--------------------|----------|----------|----------|----------|----------|----------|----------|----------|----------|
| | | 2022 | 2023 | 2024 | 2025 | 2026 | 2027 | 2028 | 2029 | 2030 | 2031 |
| A | Zone J Load Forecast | (11,116) | (11,075) | (11,052) | (11,029) | (11,031) | (11,082) | (11,151) | (11,232) | (11,308) | (11,381) |
| B | I+K to J (3) | 3,904 | 3,904 | 3,904 | 3,904 | 3,904 | 3,904 | 3,904 | 3,904 | 3,904 | 3,904 |
| C | ABC PARs to J | (11) | (11) | (11) | (11) | (11) | (11) | (11) | (11) | (11) | (11) |
| D | Total J AC Import (B+C) | 3,893 | 3,893 | 3,893 | 3,893 | 3,893 | 3,893 | 3,893 | 3,893 | 3,893 | 3,893 |
| E | Loss of Source Contingency | (980) | (980) | (980) | (980) | (980) | (980) | (980) | (980) | (980) | (980) |
| F | Resource Need (A+D+E) | (8,203) | (8,162) | (8,139) | (8,116) | (8,118) | (8,169) | (8,238) | (8,319) | (8,395) | (8,468) |
| G | Resources needed after N-1-1 (A+D) | (7,223) | (7,182) | (7,159) | (7,136) | (7,138) | (7,189) | (7,258) | (7,339) | (7,415) | (7,488) |
| H | J Generation (1) | 9,602 | 8,809 | 8,809 | 8,195 | 8,195 | 8,195 | 8,195 | 8,195 | 8,195 | 8,195 |
| I | Temperature Based Generation Derates (2) | 0 | 0 | 0 | 0 | 0 | 0 | 0 | 0 | 0 | 0 |
| J | Net ICAP External Imports | 315 | 315 | 315 | 315 | 315 | 315 | 315 | 315 | 315 | 315 |
| K | Total Resources Available (H+I+J) | 9,917 | 9,124 | 9,124 | 8,510 | 8,510 | 8,510 | 8,510 | 8,510 | 8,510 | 8,510 |
| L | Resources available after N-1-1 (E+K) | 8,937 | 8,144 | 8,144 | 7,530 | 7,530 | 7,530 | 7,530 | 7,530 | 7,530 | 7,530 |
| M | Transmission Security Margin (F+K) | 1,714 | 962 | 985 | 394 | 392 | 341 | 272 | 191 | 115 | 42 |

Notes:

1. Reflects the 2021 Gold Book existing summer capacity plus projected additions, deactivations, and de-rates. For this evaluation wind generation is assumed to have 0 MW output, solar generation is based on the ratio of solar PV nameplate capacity (2021 Gold Book Table I-9a) and solar PV peak reductions (2021 Gold Book Table I-9c). De-rates for run-of-river hydro is included as well as the Oswego Export limit of for all lines in-service.
2. Includes de-rates for thermal resources.
3. The I+K to J flows are based on N-1-1-0 analysis in the post-RNA updates utilizing the models representing summer peak 2030.

Considering the baseline peak load transmission security margin (42 MW observed in 2031), many different loss of generation or load increases will exceed the transmission security margin. For example, as can be seen in **Figure XX, Figure 6**, loss of any generator, load increase, or combination that creates an outage combination of 394 MW will tip Zone J over its security margin by 2025. The fluctuations in transmission security margin from year-to-year are a combination of the impact of the peaker rule and load forecast.

Figure XX: Zone J Summer Transmission Security Margin (Summer Baseline Peak Forecast - Normal)

| Line | Item | Peak Load Forecast | | | | | | | | | |
|------|--|--------------------|----------|----------|----------|----------|----------|----------|----------|----------|----------|
| | | 2022 | 2023 | 2024 | 2025 | 2026 | 2027 | 2028 | 2029 | 2030 | 2031 |
| A | Zone J Load Forecast | (11,116) | (11,075) | (11,052) | (11,029) | (11,031) | (11,082) | (11,151) | (11,232) | (11,308) | (11,381) |
| B | I+K to J | 3,904 | 3,904 | 3,904 | 3,904 | 3,904 | 3,904 | 3,904 | 3,904 | 3,904 | 3,904 |
| C | ABC PARs to J | (11) | (11) | (11) | (11) | (11) | (11) | (11) | (11) | (11) | (11) |
| D | Total J AC Import (B+C) | 3,893 | 3,893 | 3,893 | 3,893 | 3,893 | 3,893 | 3,893 | 3,893 | 3,893 | 3,893 |
| E | Loss of Source Contingency | (980) | (980) | (980) | (980) | (980) | (980) | (980) | (980) | (980) | (980) |
| F | Resource Need (A+D+E) | (8,203) | (8,162) | (8,139) | (8,116) | (8,118) | (8,169) | (8,238) | (8,319) | (8,395) | (8,468) |
| G | Resources needed after N-1-1 (A+D) | (7,223) | (7,182) | (7,159) | (7,136) | (7,138) | (7,189) | (7,258) | (7,339) | (7,415) | (7,488) |
| H | J Generation (1) | 9,602 | 8,809 | 8,809 | 8,195 | 8,195 | 8,195 | 8,195 | 8,195 | 8,195 | 8,195 |
| I | Temperature Based Generation Derates (2) | 0 | 0 | 0 | 0 | 0 | 0 | 0 | 0 | 0 | 0 |
| J | Net ICAP External Imports | 315 | 315 | 315 | 315 | 315 | 315 | 315 | 315 | 315 | 315 |
| K | Total Resources Available (H+I+J) | 9,917 | 9,124 | 9,124 | 8,510 | 8,510 | 8,510 | 8,510 | 8,510 | 8,510 | 8,510 |
| L | Resources available after N-1-1 (E+K) | 8,937 | 8,144 | 8,144 | 7,530 | 7,530 | 7,530 | 7,530 | 7,530 | 7,530 | 7,530 |
| M | Transmission Security Margin (F+K) | 1,714 | 962 | 985 | 394 | 392 | 341 | 272 | 191 | 115 | 42 |

Notes:

1. Reflects the 2021 Gold Book existing summer capacity plus projected additions, deactivations, and de-rates. For this evaluation wind generation is assumed to have 0 MW output, solar generation is based on the ratio of solar PV nameplate capacity (2021 Gold Book Table I-9a) and solar PV peak reductions (2021 Gold Book Table I-9c). De-rates for run-of-river hydro is included as well as the Oswego Export limit of for all lines in-service.
2. Includes de-rates for thermal resources.

The most limiting contingency combination for the design criteria transmission security margin in Zone J is the loss of Ravenswood 3 and Dunwoodie-Mott Haven (Q12) 345 kV. Following those outages, the power flowing into Zone J from other New York zones is 3,904 MW as shown in line item B.

Other contingency combinations result in different power flows into Zone J. For example, in considering the possible combinations of N-1-1-0 events these can include a mix of generation and transmission, two transmission events, or two generation events. Figure 7 shows the transmission security margin for the outage combinations of: (1) Ravenswood 3 and Dunwoodie-Mott Haven - Rainey 345 kV (Q12) 345 kV, (2) Ravenswood 3 and Bayonne Energy Center, and (3) Sprain Brook-W. 49th St. 345 kV (M51 and M52). For outages of Ravenswood 3 and Bayonne Energy Center, the power flowing into Zone J from other New York zones is 4,717 MW. For Sprain Brook-W. 49th St. 345 kV (M51 and M52) the power flowing into Zone J from other New York zones is 3,191 MW. As seen in Figure 7, the outage combination that results in the lowest interface flow (loss of M51/M52) does not necessarily result in the worst design criteria transmission security margin.

Figure 7: Zone J Transmission Security Margins for Key Contingencies

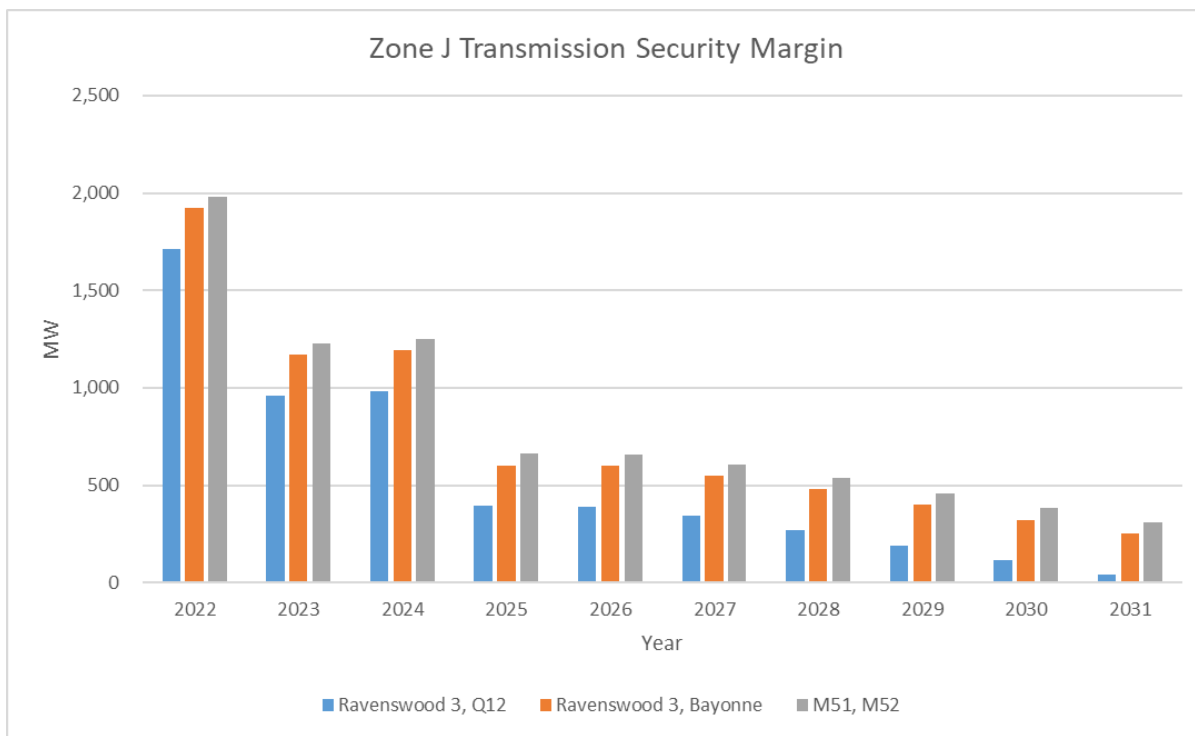

As shown in **Figure 8**, under baseline load conditions, the transmission security margin (line item H) ranges between 2,303 MW in 2022 to 1,318 MW in 2031. The annual fluctuations are driven by the changes in NYCA generation (line-item A) and the load forecast (line-item F). In consideration of the transmission security margin (line-item H) and the single largest loss of source (1,310 MW loss of Nine Mile Unit 2), the values show that the system would not cross a tipping point.¹⁴ However, in 2031 this combination of conditions results in a transmission security margin of 8 MW.¹⁵ Therefore, it is feasible for other combinations of events to tip the system over its margin, such as increased load or a combination of reductions in total resources and load.

¹⁴ <https://www.nyiso.com/documents/20142/3691300/Summer-2020-Operating-Study-Draft-Final-OC-Approved.pdf/>

¹⁵ This value is calculated as 1,318 MW - 1,310 MW = 8 MW.

Figure 8: NYCA Summer Transmission Security Margin (Summer Baseline Peak Forecast – Normal)

| Line | Item | Peak Load Forecast | | | | | | | | | |
|------|---|--------------------|----------|----------|----------|----------|----------|----------|----------|----------|----------|
| | | 2022 | 2023 | 2024 | 2025 | 2026 | 2027 | 2028 | 2029 | 2030 | 2031 |
| A | NYCA Generation (1) | 35,257 | 34,307 | 34,297 | 33,684 | 33,679 | 33,679 | 33,674 | 33,669 | 33,664 | 33,659 |
| B | External Area Interchanges (2) | 1,844 | 1,844 | 1,844 | 1,844 | 1,844 | 1,844 | 1,844 | 1,844 | 1,844 | 1,844 |
| C | Temperature Based Generation Derates | 0 | 0 | 0 | 0 | 0 | 0 | 0 | 0 | 0 | 0 |
| D | Total Resources (A+B+C) | 37,101 | 36,151 | 36,141 | 35,528 | 35,523 | 35,523 | 35,518 | 35,513 | 35,508 | 35,503 |
| E | Load Forecast | (32,178) | (31,910) | (31,641) | (31,470) | (31,326) | (31,278) | (31,284) | (31,348) | (31,453) | (31,565) |
| F | Operating Reserve Requirement | (2,620) | (2,620) | (2,620) | (2,620) | (2,620) | (2,620) | (2,620) | (2,620) | (2,620) | (2,620) |
| G | Total Capability Requirement (E+F) | (34,798) | (34,530) | (34,261) | (34,090) | (33,946) | (33,898) | (33,904) | (33,968) | (34,073) | (34,185) |
| H | Transmission Security Margin (D+G) | 2,303 | 1,621 | 1,880 | 1,438 | 1,577 | 1,625 | 1,614 | 1,545 | 1,435 | 1,318 |

Notes:

1. Reflects the 2021 Gold Book existing summer capacity plus projected additions, deactivations, and de-rates. For this evaluation wind generation is assumed to have 0 MW output, solar generation is based on the ratio of solar PV nameplate capacity (2021 Gold Book Table I-9a) and solar PV peak reductions (2021 Gold Book Table I-9c). De-rates for run-of-river hydro is included as well as the Oswego Export limit of for all lines in-service.
2. Interchanges are based on ERAG MMWG values.

| Line | Item | Peak Load Forecast | | | | | | | | | |
|------|---|--------------------|----------|----------|----------|----------|----------|----------|----------|----------|----------|
| | | 2022 | 2023 | 2024 | 2025 | 2026 | 2027 | 2028 | 2029 | 2030 | 2031 |
| A | NYCA Generation (1) | 35,257 | 34,307 | 34,297 | 33,684 | 33,679 | 33,679 | 33,674 | 33,669 | 33,664 | 33,659 |
| B | External Area Interchanges (2) | 1,844 | 1,844 | 1,844 | 1,844 | 1,844 | 1,844 | 1,844 | 1,844 | 1,844 | 1,844 |
| C | Temperature Based Generation Derates | 0 | 0 | 0 | 0 | 0 | 0 | 0 | 0 | 0 | 0 |
| D | Total Resources (A+B+C) | 37,101 | 36,151 | 36,141 | 35,528 | 35,523 | 35,523 | 35,518 | 35,513 | 35,508 | 35,503 |
| E | Load Forecast | (32,178) | (31,910) | (31,641) | (31,470) | (31,326) | (31,278) | (31,284) | (31,348) | (31,453) | (31,565) |
| F | Operating Reserve Requirement | (2,620) | (2,620) | (2,620) | (2,620) | (2,620) | (2,620) | (2,620) | (2,620) | (2,620) | (2,620) |
| G | Total Capability Requirement (E+F) | (34,798) | (34,530) | (34,261) | (34,090) | (33,946) | (33,898) | (33,904) | (33,968) | (34,073) | (34,185) |
| H | Transmission Security Margin (D+G) | 2,303 | 1,621 | 1,880 | 1,438 | 1,577 | 1,625 | 1,614 | 1,545 | 1,435 | 1,318 |

Notes:

1. Reflects the 2021 Gold Book existing summer capacity plus projected additions, deactivations, and de-rates. For this evaluation wind generation is assumed to have 0 MW output, solar generation is based on the ratio of solar PV nameplate capacity (2021 Gold Book Table I-9a) and solar PV peak reductions (2021 Gold Book Table I-9c). De-rates for run-of-river hydro is included as well as the Oswego Export limit of for all lines in-service.
2. Interchanges are based on ERAG MMWG values.

Risk Factors to the Comprehensive Reliability Plan

The RNA and CRP findings reflect the base case assumptions, which were set in accordance with NYISO's procedures. Complete details of the assumptions reside in the final RNA report; highlights are in Appendix C of this report.

There are, however, risk factors that could adversely affect the implementation of the plan and hence system reliability over the 2024-2030 planning horizon. If any of these factors materialize, the NYISO will assess the potential impacts and, if necessary, perform an evaluation to determine whether the NYISO should solicit solutions under the Generation Deactivation Process or Gap Solution ~~p~~PProcess, as required. The risk factors include:

1. Changes to System Resources

Substantial uncertainties exist in the next ten years that will impact the system resources. These uncertainties include, but are not limited to:

- a) If expected generation projects are not built, a system deficiency may occur. The base cases include approximately 670 MW of assumed generation additions in various planning stages, and approximately 5,150 MW of assumed generation deactivated, or not available during the summer peak (*see* Appendix C for details). The 2020 RNA also included a "status-quo" scenario. This scenario evaluated the reliability of the system under the assumption that no major transmission or generation projects come to fruition within the RNA Study Period. This included the removal of all proposed transmission and generation projects that have met 2020 RNA Base Case inclusion rules and removal of generators that require modifications to comply with the DEC's Peaker Rule. From a resource adequacy perspective, this scenario indicates that ~~F~~From a transmission security perspective, N-1-1 steady state issues in addition to those observed in the RNA baseline results may also occur.
- b) If additional generating units become unavailable or deactivate beyond those units already planned for, the reliability of the New York Control Area (NYCA) could be adversely affected. There are numerous risk factors related to the continued viability, compliance with emissions requirements, and operation of aging generating units. Depending on the units affected, the NYISO may need to take actions through its Short-Term Reliability Process to maintain reliability. The scenarios performed as part of the RNA indicated that the deactivation of additional generators could lead to reliability needs, in the absence of any other changes to transmission and/or generation.

- c) Capacity resources could decide to offer into markets in other regions and, therefore, some of the capability of those resources may not be available to the NYCA. Accordingly, the NYISO will continue to monitor imports, exports, generation, and other infrastructure.

The impact of the unavailability of system resources can readily be seen through tipping point evaluations. While transmission security within New York City (Zone J) is maintained through the ten-year period in accordance with design criteria, the margin would be very tight starting in 2025 and would be deficient beginning in 2028 if forced outages are experienced at the historical rate. The design criteria margin and adjusted baseline transmission security margin considering the impact of forced generator outages for New York City are shown in **Figure 9**. While transmission security within PSEG-Long Island (Zone K) is maintained through the ten-year period in accordance with design criteria the margin is slimmest in the first few years of the ten-year period. If forced outages are experienced at the historical rate the margin would be sufficient through the study period.

Figure 9: New York City Summer Transmission Security Margin (Summer Baseline Peak Forecast - Normal)

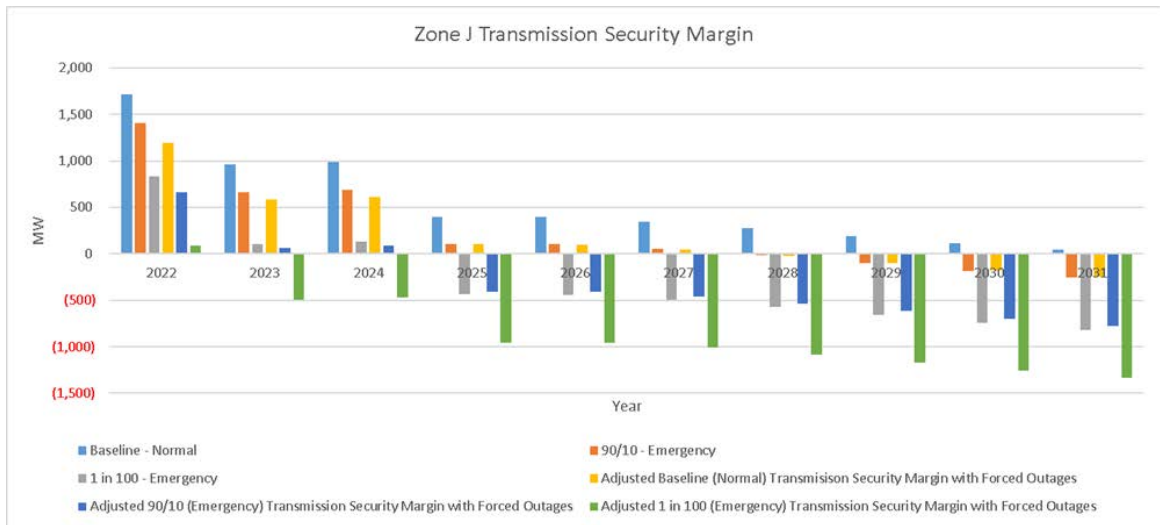

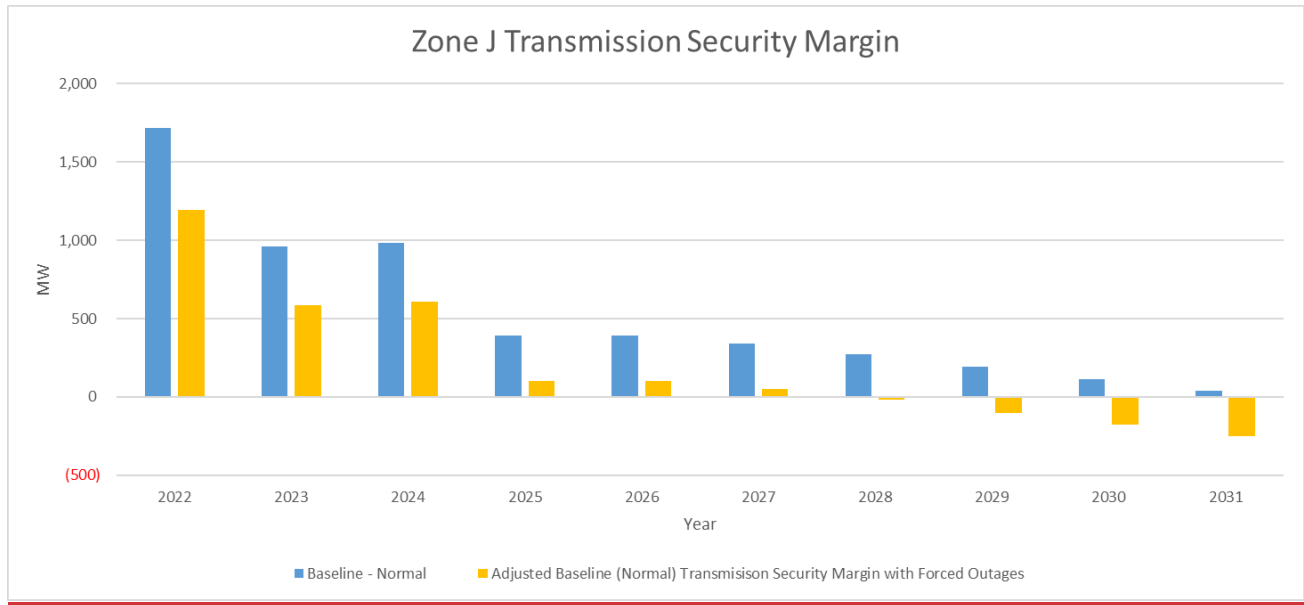
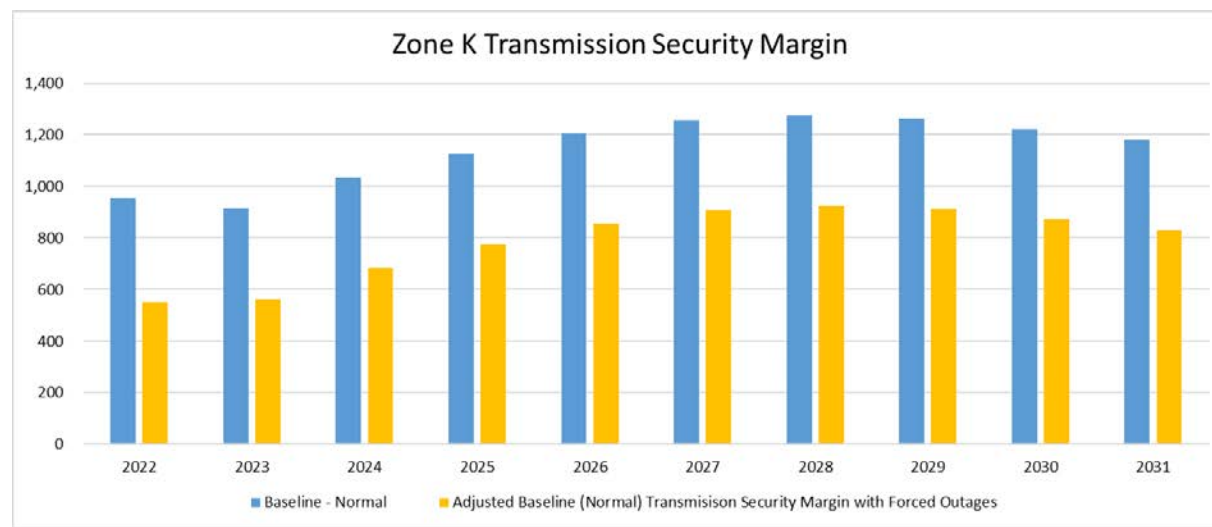

Figure 10: PSEG-Long Island Summer Transmission Security Margin (Summer Baseline Peak Forecast - Normal)



2. Completion of Public Policy Transmission Plans

There are several public policy transmission developments in progress that will increase the system capability to transport power:

- The Western NY Public Policy Transmission Project (the Empire State Line Proposal 1, Q545A), developed by NextEra Energy Transmission New York, Inc., was selected by the NYISO Board in October 2017 and was included in the reliability plan starting with the 2018 RNA. This project includes a new 345 kV circuit and phase angle regulator (PAR) that will alleviate constraints in the Niagara area. The planned in-service date for this project is summer 2022.
- The solutions to the AC Transmission Public Policy Transmission Needs were reflected in the 2020 RNA base case and are now included in this reliability plan. As part of the NYISO’s Public Policy Transmission Planning Process, the New York State Public Service Commission (PSC) identified the need to expand the state’s transmission capability to deliver additional power from generating facilities located in upstate New York, including important renewable resources, to the population centers located downstate. On April 8, 2019, the NYISO Board of Directors selected the Double-Circuit project (Q556) proposed jointly by LS Power Grid New York and the New York Power Authority as the more efficient or cost-effective transmission solution to address Segment A. The Board also selected the New York Energy Solution project (Q543) proposed jointly by Niagara Mohawk Power Corporation d/b/a National Grid and the New York Transco, LLC as the more efficient or cost-effective transmission solution to address Segment B. The planned in-service date for the Segment A and Segment B projects is winter 2023.

As these transmission projects enter service, reliability of the New York grid will improve. If the projects were to be delayed for any reason, there would be an increased risk to grid reliability.

As an example of the reliability benefits provided by the projects, the AC Segment B project has a direct impact on the Lower Hudson Valley transmission security margin. **Figure XX** **Figure 11** shows how the transmission security margin changes through time in consideration of the most limiting contingency combination for the year being evaluated. In years 2022 and 2023 (prior to the completion of the Segment B project) the most limiting contingency combination to the transmission security margin under peak load conditions is the loss of Leeds-Pleasant Valley (92) 345 kV followed by the loss of Dolson – Rock Tavern (DART44) 345 kV and Coopers Corners – Rock Tavern (CCRT34) due to common towers. For the remainder of the years the contingency combination changes to the loss of Ravenswood 3 followed by the loss of Pleasant Valley-Wood St. 345 kV (F30/F31).

Figure XX:11: Lower Hudson Valley Summer Transmission Security Margin (Summer Baseline Peak Forecast - Normal)



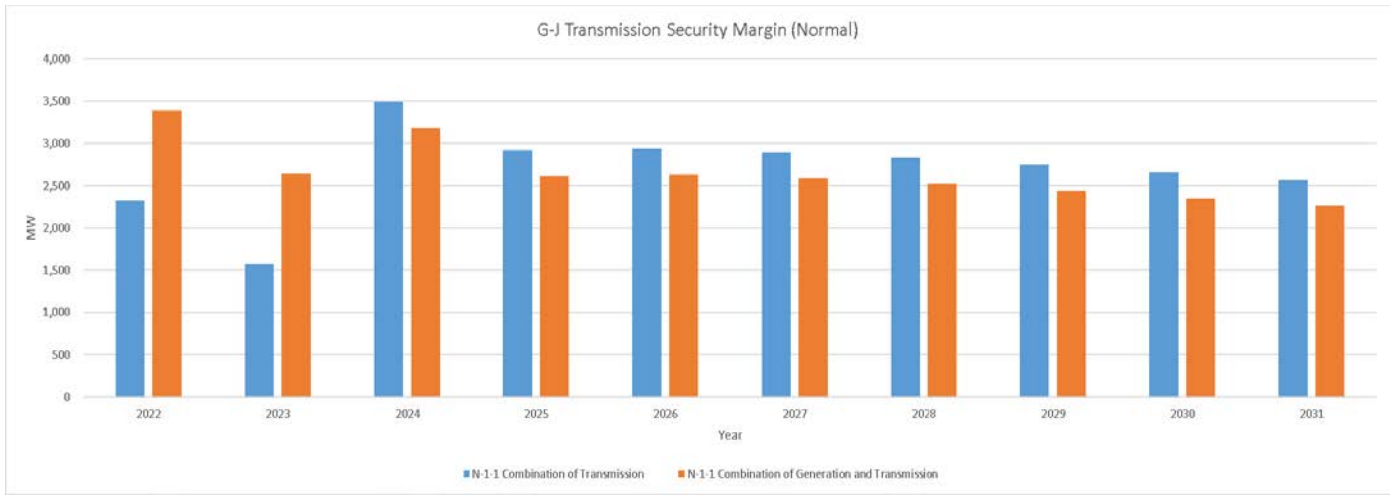

3. Completion of Local Transmission Owner Plans

The local transmission owner plans (LTPs) are an important part of the overall Comprehensive System Planning Process and the findings of this CRP. The 2020 RNA identified transmission security criteria violations, as well as resource adequacy violations. The process allows for subsequent updates, which included three projects in Con Edison: a new 345/138 kV PAR controlled 138 kV Rainey – Corona feeder, a new 345/138 kV PAR controlled 138 kV Gowanus – Greenwood feeder, and a new 345/138 kV PAR controlled 138 kV Goethals – Fox Hills feeder. These are included in the plan. The NYISO will continue to track the timely entry into service of these and other projects that have been identified to relieve reliability violations.

4. Changes to System Performance

As generators age and experience more frequent and longer duration outages, the costs to maintain the assets increase. This may drive aging generation into retirement. A growing amount of New York’s gas-turbine and fossil fuel-fired steam-turbine capacity is reaching an age at which, nationally, a vast majority of similar capacity has been deactivated. As shown in Figure 1, by 2028 more than 8,300 MW of gas-turbine and steam-turbine based capacity in New York will reach an age beyond which 95% of these types of generators have deactivated.

Figure 12: Cumulative NYCA Nameplate Capacity MW Past the Age When 95% of Similar Units Have Retired

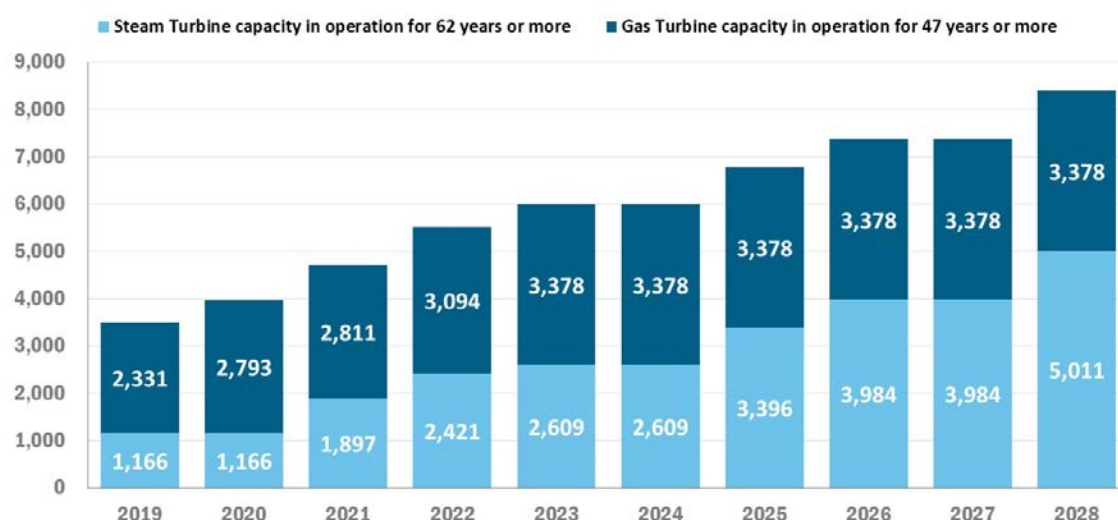

Source: <https://www.nyiso.com/documents/20142/2223020/2019-Power-Trends-Report.pdf>

5. Changes to System Load Level

A higher-than-studied load level could expose the system to potential reliability issues, necessitating interim operating procedures up to and including measures such as load shedding in some localized areas of the state. In conducting a resource adequacy scenario in the 2020 RNA with a high load forecast, approximately 2,400 MW higher than the 2020 Gold Book baseline forecast, the NYISO found that the LOLE would exceed criteria two years earlier. However, the NYISO is forecasting a decrease in energy usage during 2021 through 2030 period, which can be attributed in part to the increasing impact of energy efficiency initiatives and increasing amounts of behind the meter solar generation. Conversely, significant load-increasing impacts are forecasted due to electric vehicle usage and other electrification (*i.e.*, conversion of home heating, cooking, water heating and other end-uses from fossil-fuel based systems to electric systems). The relative behind-the-meter-solar impact on peak load declines over time as the New

York summer peak is expected to shift further into the evening, when solar resources are unavailable. New York is projected to become a winter peaking system in future decades due to electrification, primarily via heat pumps and electric vehicles.

In the past decade, energy provided by the bulk grid has decreased, while energy production from ~~distributed energy resources~~ [Distributed Energy Resources](#) (DERs), such as solar, has increased. These DERs are beginning to displace energy that was traditionally supplied by conventional generation through the regional electricity grid. The energy provided by many DERs is not continuous, but intermittent, and less visible to the NYISO markets and operations.

The NYISO will continue to report on energy usage and peak demand trends in its annual Load and Capacity Data Report ~~(“Gold Book”)~~.

6. Extreme Weather

The dangers of severe weather impacting the grid have been exemplified around the country in the past year, with Texas experiencing a brutal polar vortex in February and California facing problems from extreme heat last summer. In New York, the frigid¹⁶ winter of 2013-14 offered a number of lessons that continue to serve energy reliability today. In the end, New York suffered no electric customer outages from the polar vortex of 2014. In fact, it strengthened our reliability by enabling us to prepare the NYISO for the next cold wave. Since then, a number of resilience measures were instituted, including:

- **Improved** operator awareness of fuel inventories and replacement fuel schedules, including a web-based application for generators;
- **Changes** to our tariff to increase the amount of reserve power available;
- **Expanded** generator site visits to review preparations for cold conditions;
- **Reduced** the number of generators that can be scheduled offline for maintenance; and
- **Improved** outreach and coordination with the gas delivery industry, including operator awareness of the natural gas pipeline availability.

In consideration of these risk factors related to load and extreme weather, it is feasible to “tip” the system into a violation of transmission security criterion. **Figure 13** shows the transmission security margin in Zone J considering peak, 90/10 and 1-in-100 load forecasts and the impact of forced generation outages (including SCRs). As seen in **Figure 13** most of these conditions are tipped. Similarly, these risk factors may also cause the system to tip as shown in **Figure 14** [for Zone K](#) and **Figure 15** [for NYCA](#).

¹⁶ The vortex hit in earnest in early January 2014. On Jan 7, the high in Central Park was 4 degrees F, breaking a low record set in 1896.

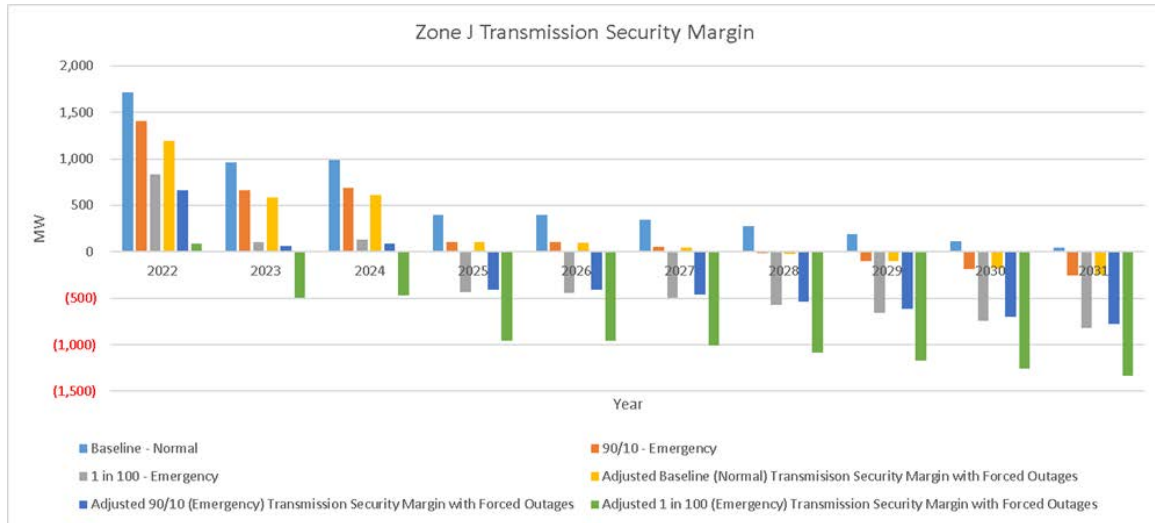

Figure 13: New York City Summer Transmission Security Margin

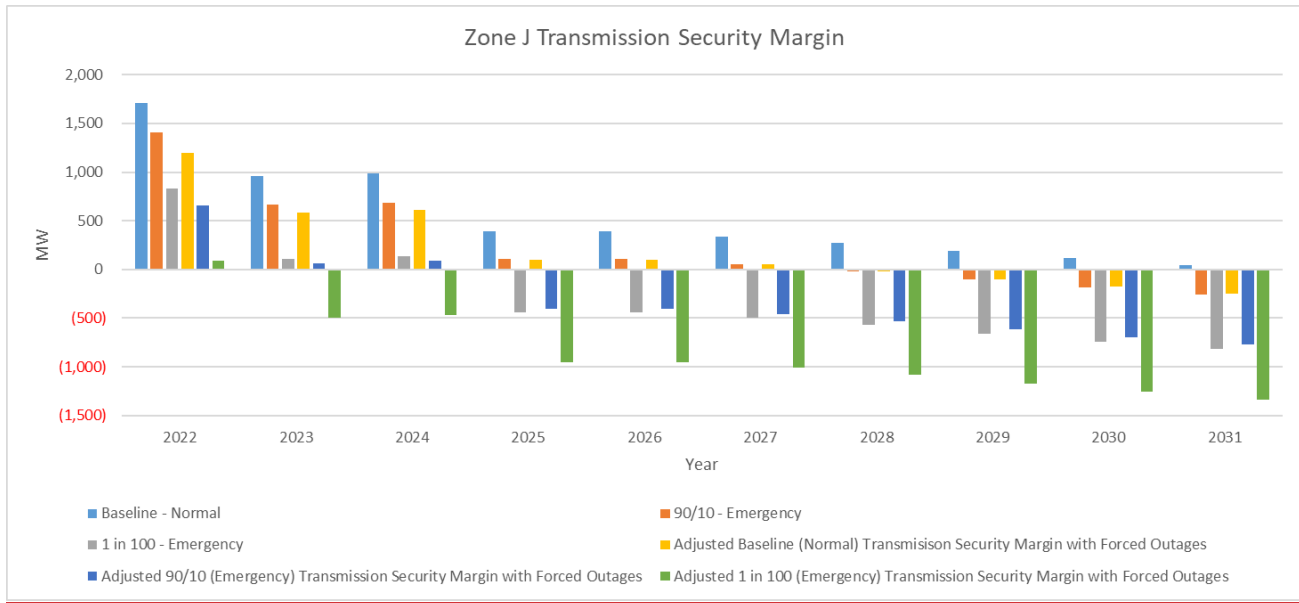

Figure 14: PSEG-Long Island Summer Transmission Security Margin (Summer Baseline Peak Forecast - Normal)

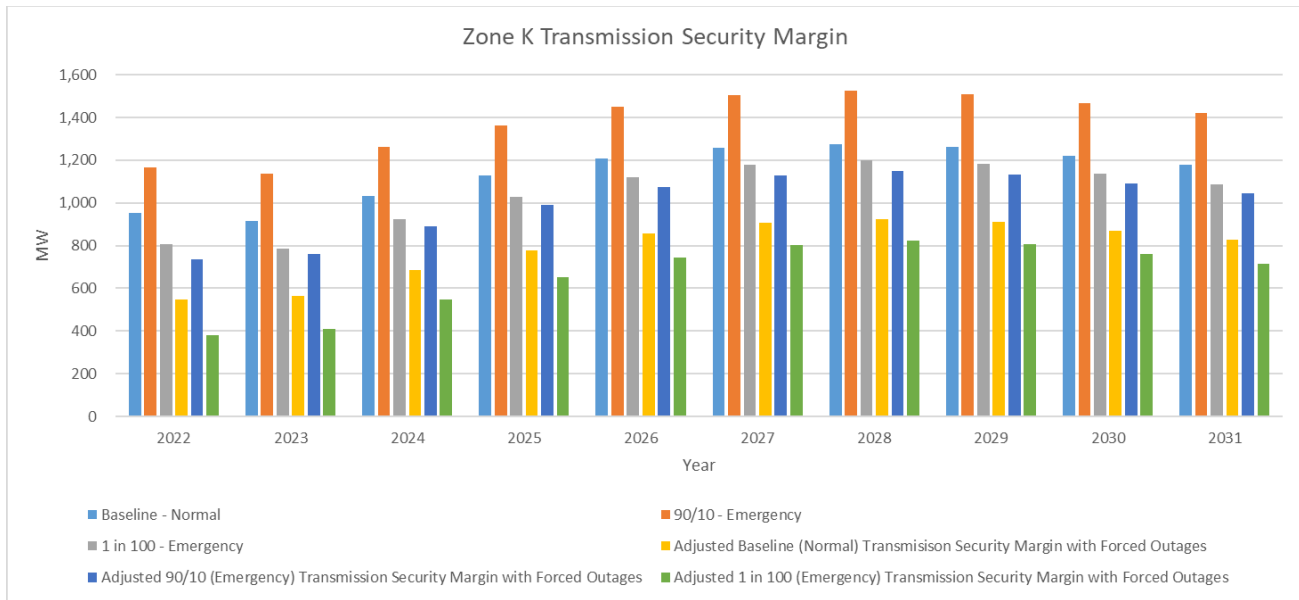
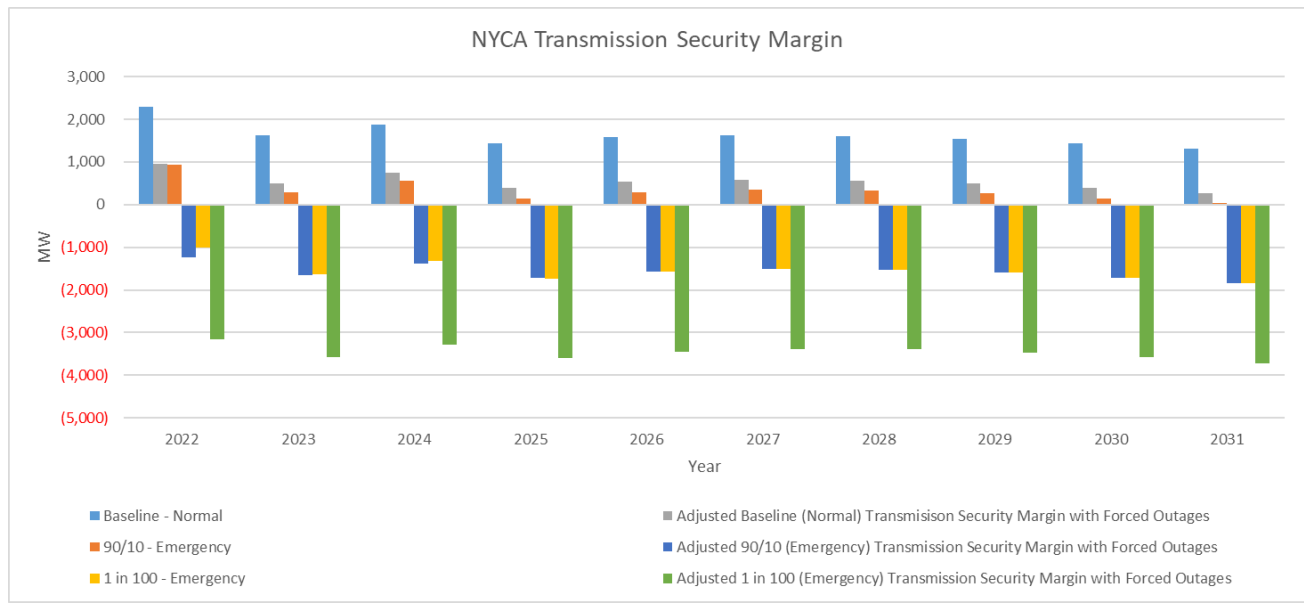

Figure 15: NYCA Summer Transmission Security Margin (Summer Baseline Peak Forecast - Normal)



Safeguards to the Comprehensive Reliability Plan

The work of the NYISO is distinct from the role that the Texas ([ERGOT](#)) and California ([CAISO](#)) grid operators play in their regions. Primary among those differences are the NYISO's capacity markets and planning functions. For instance:

1. New York has an Installed Capacity Market

A main part of the NYISO's mission is to manage the operation of the grid in New York and administer the wholesale electricity markets by which power and grid reliability services are bought and sold. One important grid reliability service – resource adequacy – is bought and sold through the Installed Capacity (ICAP) market. This is a major difference between the NYISO markets and those of Texas and California.

Resource adequacy promotes reliability by making sure that enough generating capability is available to meet grid demand at peak times of electricity consumption. The NYISO's capacity market offers a forum for buying and selling capacity through competitive auctions. Auctions are conducted monthly and for the summer and winter seasons. Consumers benefit from competitive auctions that minimize consumer costs. Investors in new technologies benefit from transparent locational pricing. Existing suppliers benefit from investment signals that reward units for maintaining or upgrading their performance. Our centralized capacity market offers price transparency to spur competition and drive costs down for maintaining resource adequacy. The capacity market also includes specific rules to incent performance and availability of resources when system needs are expected to be greatest as well as stiff penalties for non-performance. Texas and California lack capacity markets.

In addition, the NYISO's planning processes include generator deactivation studies and periodic assessments of both resource adequacy and transmission system needs to identify risks to reliability, and to act if necessary.

2. New York has Regional Coordination

California, like the NYISO, imports energy from several neighboring states. Texas, however, generally does not. In New York, both energy and capacity are imported from and exported to neighboring regions, benefiting reliability in the region and strengthening market competition. Resources importing capacity services into New York must meet strict market rules, just like resources located within the state, to be eligible to serve New York consumers.

3. New York has a Diverse Fuel Mix

In New York, the electricity that comes out of the wall of your business or home originates from many different sources. According to recent [2021 Power Trends](#) report, in 2019 a third of New York’s energy production was from dual-fuel generators that run primarily on natural gas but have the ability to use other fuels as well. Another third came from nuclear energy, and nearly a quarter came from hydropower.

In comparison, accounts of the incidents in California point to the state reducing fossil fuel and nuclear generating capability, leaving the state with fewer resources to balance the grid on days when there is reduced wind or clouds obscuring the sun. As CAISO’s report to the governor said, “[I]n transitioning to a reliable, clean and affordable resource mix, resource planning targets have not kept pace to lead to sufficient resources that can be relied upon to meet demand in the early evening hours.”

The NYISO followed closely the events in the south-central states related to cold weather-related outages. On February 17, 2021, the Federal Energy Regulatory Commission (FERC) and the Northeast Electric Reliability Council (NERC) announced that they will open a joint inquiry into the operations of the bulk power system during the extreme winter weather conditions that were experienced by the midwest and south-central states. FERC and NERC indicated that they will work with other federal agencies, states, and utilities to review the performance of the bulk power system and determine what further investigation is appropriate.

For the past decade, wind and solar energy resources have played an increasingly important role in New York and their participation is expected to grow as [the NYISO market rules evolve to address these new technologies. New York approaches the CLCPA goals.](#) We have developed forecasting tools that accurately predict the levels of production from these resources, maximizing their reliability, economic, and environmental benefits. Studies such as the Reliability Needs Assessment, the “70 x 30 Scenario” in our Congestion Assessment and Resource Integration Study (CARIS), and our Climate Change Study show that wind and solar growth would require a diverse portfolio of resources to keep the grid in balance when nature does not cooperate.

Figure 16

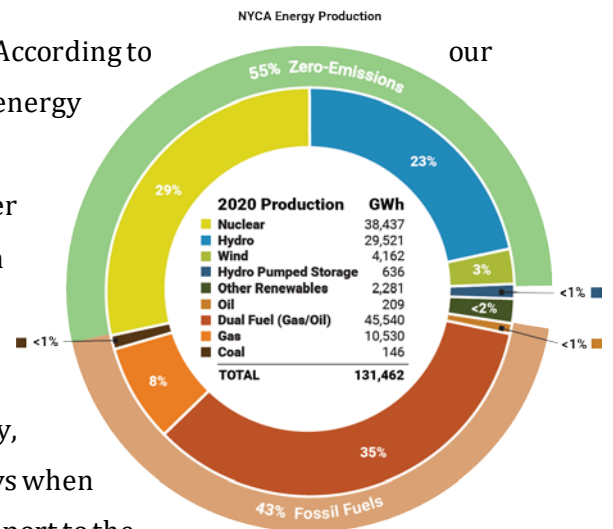

4. Clear Accountability for Non-Performance of Supply Resources

Our markets in New York help to drive out costlier, and often dirtier energy suppliers through economic competition. The NYISO coordinates with New York State to address reliability needs caused by generator deactivations. We also have a mandatory notice period for units seeking to deactivate to prepare for any potential reliability concerns.

Reliability rules require that New York carry enough capacity to meet peak demand levels, as well as additional resources to provide a margin of reliability safety for certain conditions. How do we know how much is needed? Grid planners develop models that depict what would happen to the grid if we lost the use of certain energy resources due to weather, fuel constraints, transmission outages, or other system conditions. This allows us to be ready for contingencies, including the potential loss of some of our largest supply resources.

In California, the role of resource management is shared between the independent system operator and the state. According to media accounts of outages last summer, the CAISO was unaware that certain energy resources were shut down, reducing the options of where to get electricity. As CAISO noted in its report to the governor, “the existing resource planning processes are not designed to fully address an extreme heat storm like the one experienced in mid-August.”

As we continue working on the grid of the future, we operate under the most stringent reliability rules in the nation. Our long-range reliability planning requires us to examine scenarios such as extreme weather events and unexpected transmission failures to maintain reliability. And our independent structure and shared governance process gives all members of the energy sector a say in decisions affecting our markets.

As the energy grid changes, we continue doing what we do best to make sure the energy grid in New York State stays reliable.

5. Natural Gas Coordination

While the environmental rules, such as the DEC Peaker Rule, mainly target emissions from the natural gas peaker plants, New York’s reliance on natural gas as the primary fuel for electric generation continues to justify vigilance regarding the status of the natural gas system. The NYISO is actively involved in natural

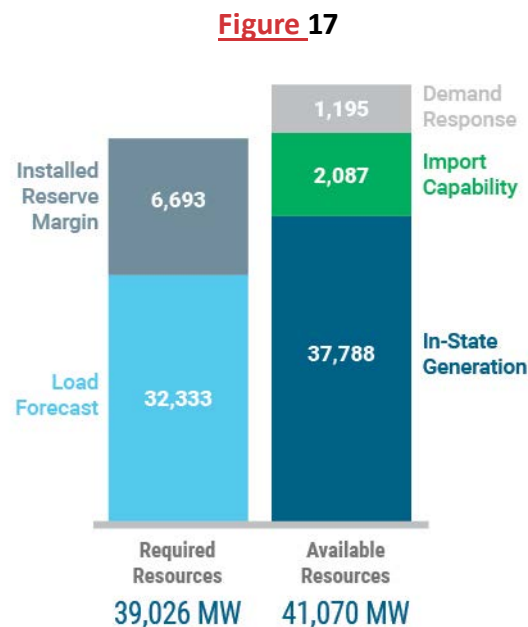

gas/electric coordination efforts with New York State and federal regulators, pipeline owners, generator owners, local distribution companies, and neighboring ISOs and Regional Transmission Operators (RTOs).

The NYISO's efforts with respect to gas supply assurance focus on: (i1) improving communication and coordination between the gas and electric sectors; (ii2) annual, weekly and, when conditions warrant, *ad hoc* generator surveys of fuel supplies to enhance awareness in the control room and provide electric system reliability benefits; and (iii3) addressing the electric system reliability impact of the sudden catastrophic loss of gas.

Beyond the CRP – Road to 2040

There have been several significant developments that are shaping how the New York electric grid of the future will develop. Part of the changes are climate related, which will drive temperatures higher and result in higher load. Part of the changes are due to state policies in response to climate change. The 2019 Climate Leadership and Community Protection Act (CLCPA), enacted in 2019, requires an economy-wide approach to addressing climate change and decarbonization.¹⁷ This includes sweeping mandates to deliver 70% of New York energy from renewable resources by 2030 and 100% emissions-free electricity supply by 2040 while promoting electrification in other sectors of the economy. Understanding the impacts due to these two driving changes on the generation, transmission, and load components of the bulk electric system is critical to understanding the challenges in the coming year.

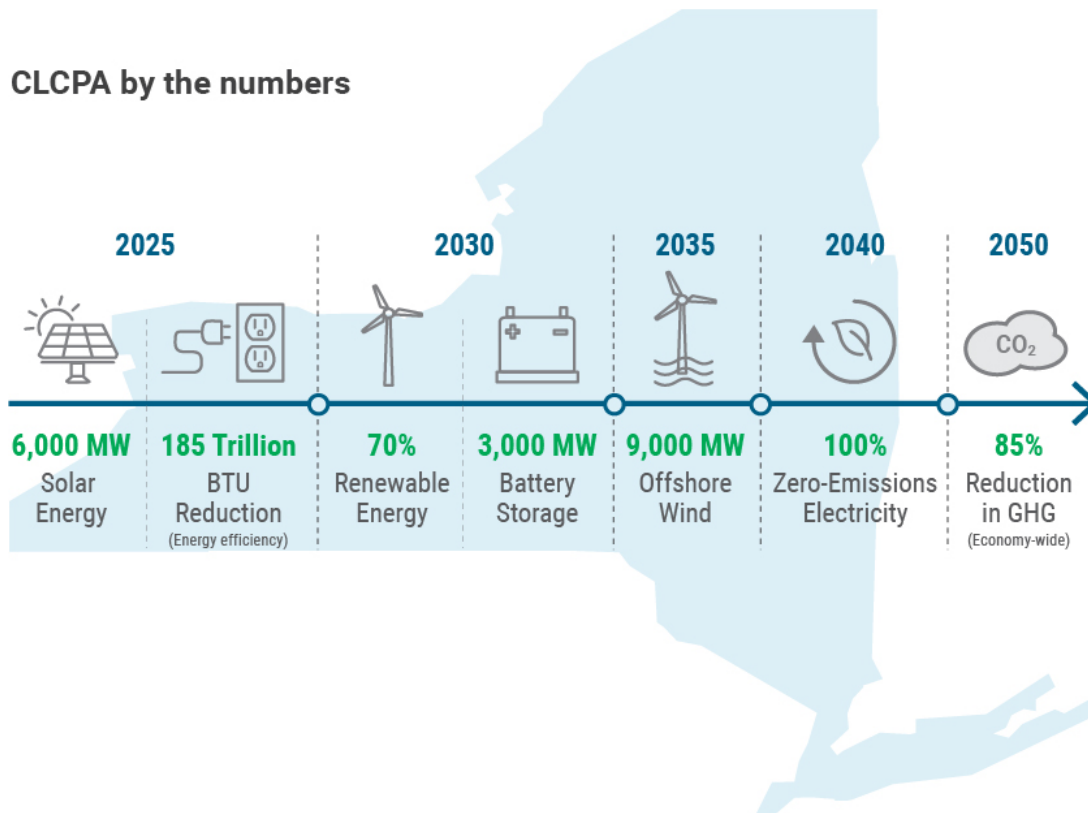

¹⁷ 2019 Laws of New York, ch. 106. The CLCPA requires that seventy percent of energy consumed in New York State be produced by renewable resources by 2030. By 2040 energy consumed must be completely emissions-free.

Load

In 2019, the NYISO commissioned a study in 2019 known as the [Climate Change Phase I Study](#) to examine the impacts that climate change will have on temperature and the resultant impact on load. The core finding from the study is that temperatures are rising across New York and will have a significant impact on summer peak demand. Since early 1990, temperatures across the state have been increasing from 0.06 to 0.09 degrees per year or 0.6 to 0.9 degrees per decade. On average, the statewide average temperature is increasing 0.7 degrees per decade. On an annual basis, increasing temperatures have minimal impact on system energy requirements as increasing cooling sales are largely mitigated by decreasing heating related sales. However, the system load profile will change over time with the strongest load growth in the shoulder months (April, May, September, and October). Summer and winter peak demand will also be significantly impacted by climate change. By 2050, increasing temperatures will potentially add between 1,600 MW to 3,800 MW or 10% to 23% of summer-peak cooling requirements. State policy designed to counter the impact of climate change may have an even larger impact on load than increasing temperatures. New state energy efficiency targets largely mitigate the impact of increasing temperatures on summer peak demand through 2045. After that point, increasing electric vehicle demand and electrification activity eventually push loads above current trends. In the most aggressive scenario, statewide electrification programs result in the system switching from a summer peaking system to a winter peaking system; this could occur around 2035. While there is still additional analysis to be done to translate greenhouse gas targets to specific end-use impacts, the amount of electrification needed to achieve state greenhouse gas targets has significant impacts on base loads, heating loads and cooling loads. An aggressive electrification program could add more than 28,000 MW to the system summer peak by 2050, and an even larger amount to winter peaks.

By 2050, increasing temperatures will potentially add between 1,600 MW to 3,800 MW or 10% to 23% of summer-peak cooling requirements. State policy designed to counter the impact of climate change may have an even

larger impact on load than increasing temperatures. New state energy efficiency targets largely mitigate the impact of increasing temperatures on summer peak demand through 2045. After that point, increasing electric vehicle demand and electrification activity eventually push loads above current trends. In the most aggressive scenario, statewide electrification programs result in the system switching from a summer peaking system to a winter peaking system; this could occur around 2035. While there is still additional analysis to be done to translate greenhouse gas targets to specific end-use impacts, the amount of electrification needed to achieve state greenhouse gas targets has significant impacts on base loads, heating loads and cooling loads. An aggressive electrification program could add more than 28,000 MW to the system summer peak by 2050, and an even larger amount to winter peaks.

The CLCPA Scenario in the study builds on the Policy Case. In addition to higher Policy Case efficiency savings, solar capacity and electric vehicle penetration, the CLCPA adds aggressive electrification in the residential and commercial sectors. The largest targeted end-use is residential fossil fuel heating; it assumes gas, oil, and propane heating systems are replaced with cold climate heat pumps with electric resistance backup to meet heating requirements on the coldest days. Other targeted end-uses including

Figure 18

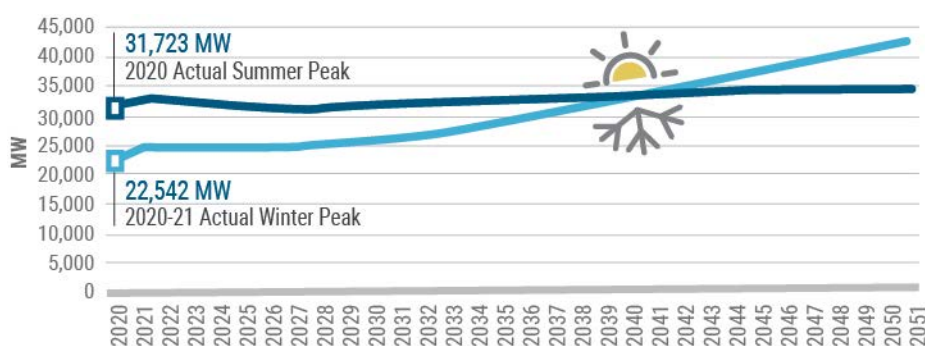

water heating, clothes drying, and cooking. By 2040, the **summer peak could be over 47,000 MW** while the **winter peak could be over 56,000 MW**.

Key takeaways

- Climate change and electrification will result in a significant increase in summer load
- CLCPA electrification will cause the NYCA to go from summer peaking to winter peaking
- The winter peak load under the CLCPA will be double compared to the reference case

Generation

The ~~Climate Leadership and Community Protection Act (CLCPA)~~ will have an enormous impact on the generation fleet. The law establishes overall general targets which include:

- ~~● 70% of electricity delivered in New York State must be derived from renewable resources by 2030;~~
- ~~● 100% of the electricity consumed in New York State must be derived from zero-emissions resources by 2040.~~

~~In addition, there are specific targets for certain types of generation, including:~~

- ~~● 9,000 MW of offshore wind installed by 2035;~~
- ~~● 6,000 MW of distributed solar energy resources installed by 2025; and~~
- ~~● 3,000 MW of energy storage installed by 2030.~~

Figure 19

CLCPA by the numbers

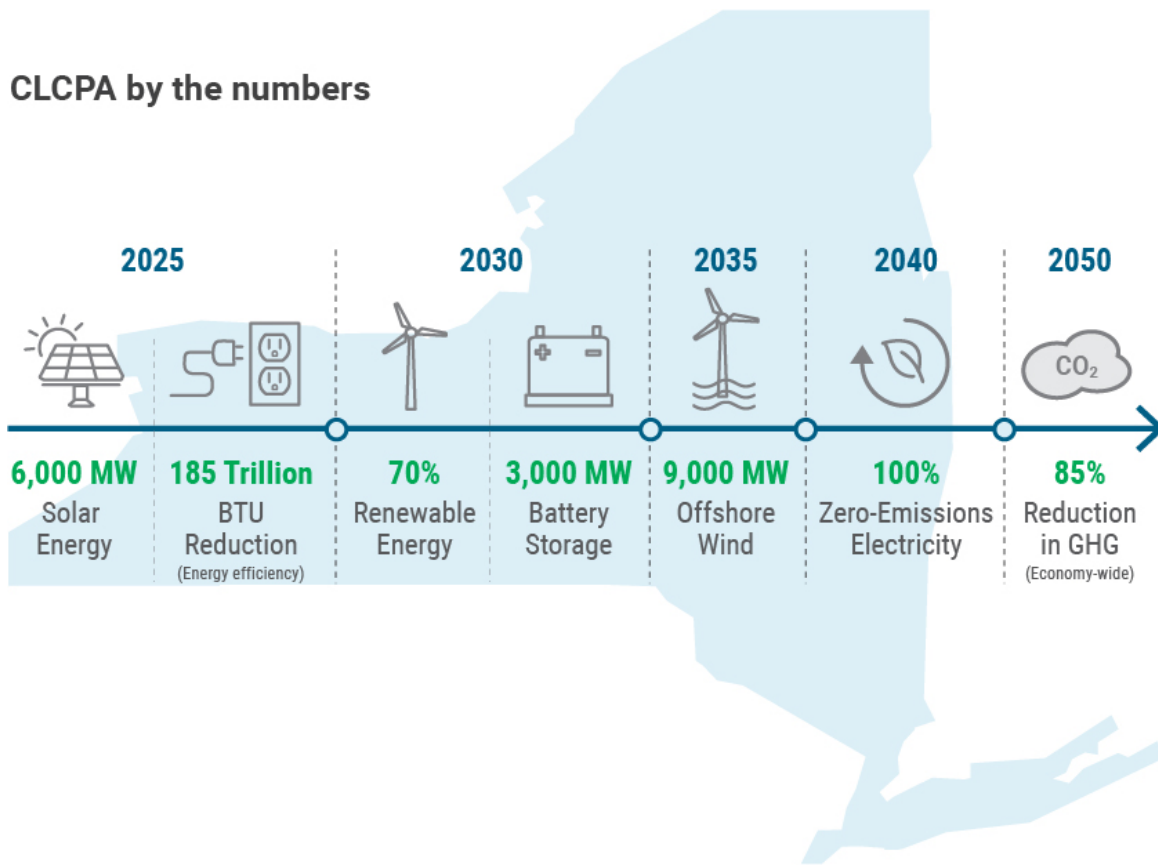

In addition to impacting the types of generation that can run in New York, the CLCPA will have a significant impact on the amount of electricity and from which resource types electricity can be imported into New York.

Generation resources in New York have already seen significant changes in the last two years with the loss of 1,000 MW of coal and 2,000 MW of nuclear from 2019 to 2020. In 2020, the New York State Department of Environmental Conservation (DEC) adopted a regulation to limit nitrogen oxides (NOx) emissions from simple-cycle combustion turbines (“(Peaking Units”)) (referred to as the “Peaker Rule”).¹⁸ This rule required peakers to submit compliance plans to state how they would meet compliance with the rule, which could include retiring or not operating those generators during the summer ozone season. The

¹⁸ ~~6 NYCRR Part 227-3. See <https://casetext.com/regulation/new-york-codes-rules-and-regulations/title-6-department-of-environmental-conservation/chapter-iii-air-resources/subchapter-a-prevention-and-control-of-air-contamination-and-air-pollution/part-227-stationary-combustion-installations/subpart-227-3-ozone-season-oxides-of-nitrogen-ox-emission-limits-for-simple-cycle-and-regenerative-combustion-turbines>~~ 6 NYCRR Part 227-3. See <https://casetext.com/regulation/new-york-codes-rules-and-regulations/title-6-department-of-environmental-conservation/chapter-iii-air-resources/subchapter-a-prevention-and-control-of-air-contamination-and-air-pollution/part-227-stationary-combustion-installations/subpart-227-3-ozone-season-oxides-of-nitrogen-ox-emission-limits-for-simple-cycle-and-regenerative-combustion-turbines>

compliance plans indicated that over 1,850 MW ~~nameplate of peakerspeaker capability~~, mostly in New York City, will either retire or not operate during the summer ozone season by 2025, with a little over half impacted starting in 2023. All of these deactivations add up to almost 5,000 MW generation. An additional 25,000 MW of fossil fuel generation will need to deactivate over time to hit the targets in the CLCPA. These resources will need to be replaced by resources that are emission free and largely renewable. Discussed below are the attributes of these types of resources and the challenges inherent with them.

Intermittent Resources

Intermittent resources are not dispatchable (although they may be able to be dispatched down by spilling their energy) due to the variability of their “fuel” source. To maximize efficiencies, the location of these resources are dictated by where the wind is most constant or by where there is sufficient land for solar. This results in land-based wind locating in northern and western New York while solar resources are significantly located in these areas also. ~~Off-shore~~Offshore wind would connect primarily into New York City and Long Island. The NYISO commissioned the [Climate Change Impact and Resilience study \(“Phase II study”\)](#) that examined the resources needed to meet load in a 2040 scenario. This study looked at integrating large amounts of solar and wind resources into the model, and concluded that the variability of meteorological conditions that govern the output from wind and solar resources presents a fundamental challenge to relying on those resources to meet electricity demand. Solar resources will have little to no output during the evening and ~~night time~~nighttime hours and reduced output due to cloud cover, while wind resources can experience significant and sustained wind lulls.

To continue the study efforts on this subject, the NYISO conducted additional ‘wind lull’ scenarios for this CRP, using the ~~70x30~~70 x 30 models developed during the 2020 RNA. Wind lull scenarios simulated a one-week loss of either ~~off-shore~~Offshore wind (approximately 6,000 MW nameplate total connected to New York City and Long Island) or land-based wind (located in Upstate New York) for various weeks. For the loss of all ~~off-shore~~Offshore wind, dynamic stability of the system immediately after the wind loss was also simulated.

Loss of wind energy during an entire week impacts system reliability when the wind farms are interconnected to zones that usually drive the loss of load expectation events, such as New York City (Zone J) and Long Island (Zone K). The magnitude of the impact also depends on the amount of potential energy generated during the week of the wind lull, as well as the timing of generation during each day (e.g., peak demand vs off-peak). ~~Table xx~~Figure 20 provides the LOLE results for the most severe simulated ~~off-shore wind~~Offshore Wind (OSW) lull weeks, showing that a one-week wind lull has the potential to significantly increase the probability of a loss of load event. The ~~Figure xx~~Figure 21 shows the ~~off-~~

| shoreOffshore wind energy production during the simulated week. Details of these scenarios are provided in Appendix D.

Figure 20: Offshore Wind Lull for the Highest LOLE Week

| No OSW during the 1 st Highest NYCA Event % Week | | | | |
|---|---------|--------------|----------------|-------------|
| Model | Event % | Initial LOLE | Resultant LOLE | Delta LOLE |
| 70x30 'Base Load' at-criterion | 34% | 0.11 | 0.18 | 0.07 |
| 70x30 'Scenario Load' at-criterion | 23% | 0.11 | 0.22 | 0.11 |
| 70x30 'Scenario Load' at-low-LOLE | 24% | 0.03 | 0.06 | 0.03 |

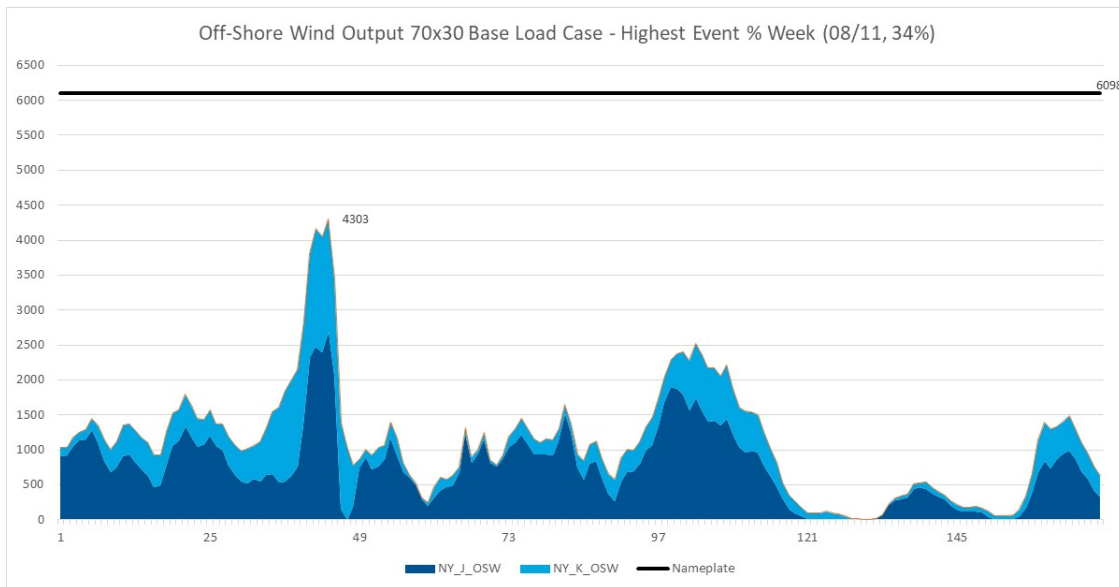

| No OSW during the 1 st Highest NYCA Event % Week | | | | |
|---|---------|--------------|----------------|-------------|
| Model | Event % | Initial LOLE | Resultant LOLE | Delta LOLE |
| 70x30 'Base Load' at-criterion | 34% | 0.11 | 0.18 | 0.07 |
| 70x30 'Scenario Load' at-criterion | 23% | 0.11 | 0.22 | 0.11 |
| 70x30 'Scenario Load' at-low-LOLE | 24% | 0.03 | 0.06 | 0.03 |

Figure 21

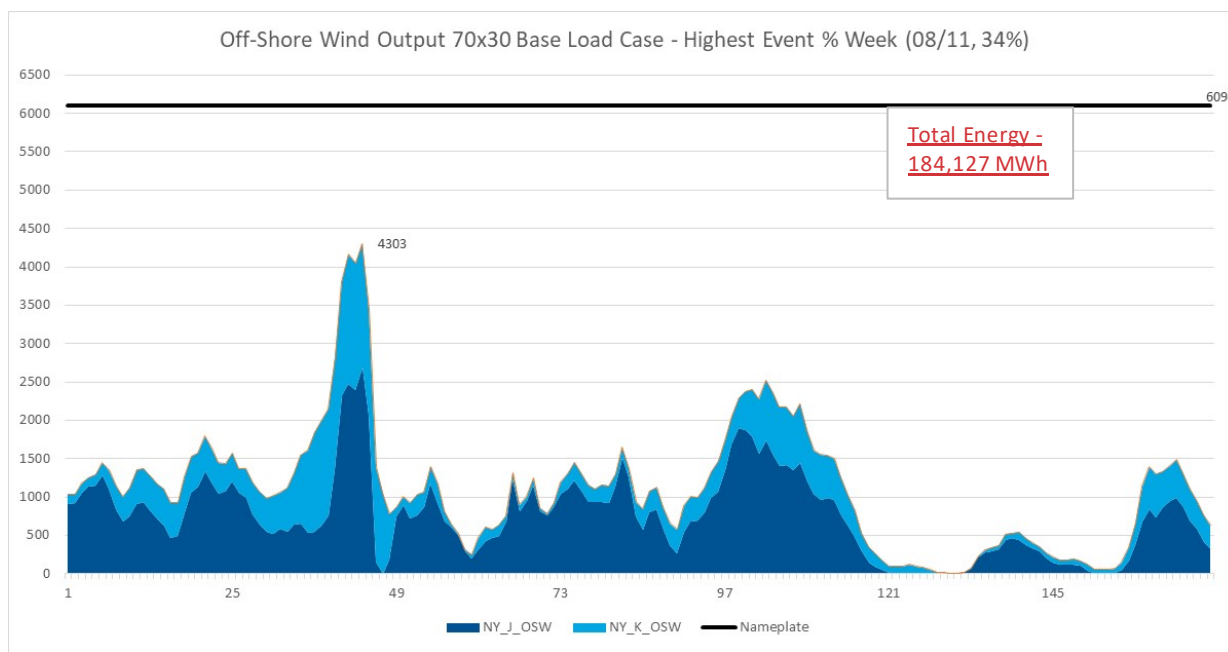

Additionally, a one-week outage of the largest generation source in Zone J (*i.e.*, loss of Ravenswood 3 steam turbine generator) was simulated for the highest event week of the 70 x 30 “Base Load” condition. The results, shown in **Figure 22**, demonstrate that a one-week outage of approximately 6,100 MW of offshore wind (4,300 MW in New York City and 1,800 MW in Long Island) could have roughly the same impact to resource adequacy as the outage of a 1,000 MW conventional (*i.e.*, non-intermittent) generator.

Figure 22

| No OSW during the 1st Highest NYCA Event % Week (34%) | | | | |
|---|---------------|--|--------------|----------------|
| Model | Removal | Nameplate MW Removal | Initial LOLE | Resultant LOLE |
| 70x30 'Base Load' at-criterion | Offshore Wind | 6098 <i>(4320 MW in J and 1778 MW in K)</i> | 0.106 | 0.179 |
| | Ravenswood 3 | 1027 | | 0.180 |

With high penetration of renewable intermittent resources, the system will need dispatchable, long-duration resources to balance intermittent supply with demand especially during extended periods where

the intermittent resources are not available. These types of resources will need to be significant in capacity, and have attributes such as the ability to come on-line quickly, stay on-line for as long as needed, maintain the system's balance and stability, and adapt to meet rapid, steep ramping needs.

Storage resources

The seasonal power capability of suppliers would typically be the main consideration when evaluating most generation resources for their ability to serve load and provide for reliability. However, with energy storage resources, there are two other critical aspects that need to be considered. The first is the duration needed from the storage device. Load duration curves can provide the context for how long a storage device may be needed for reliability. The duration of need can be a significant amount of time during a given day. The second critical aspect involves charging the storage device. Since the “fuel” for storage is electricity from local resources and the grid, the surplus energy in the “load pocket” where storage is located needs to be more than the energy that is needed from the storage device including losses. The *NYISO Climate Change Phase II study* noted that battery storage resources help to fill in voids created by reduced output from renewable resources, but periods of reduced renewable generation rapidly deplete battery storage resource capabilities (emphasis added). Additionally, the “*Pathways to Carbon-Neutral NYC*,” which was commissioned by the NYC Mayor’s Office of Sustainability, Con Edison, and National Grid, noted a stringent regulatory and siting regime for storage in New York City, including site-based limitations and fire codes regarding siting of battery storage.¹⁹

¹⁹ <https://www1.nyc.gov/assets/sustainability/downloads/pdf/publications/Carbon-Neutral-NYC.pdf>
<https://www1.nyc.gov/assets/sustainability/downloads/pdf/publications/Carbon-Neutral-NYC.pdf>

Dispatchable Resources

Given the move to a more intermittent -resource based system, the NYISO has performed several studies that have shown the need for significant amounts of dispatchable resources.

The 70 x 30 (70% renewable energy delivered to New York consumers by 2030) scenario performed in the 2020 RNA modeled a possible renewable resource mix to meet the 70 x 30 target. The RNA scenario then determined how much fossil resources would need to be retained in order to meet reliability criteria. The analysis showed that over 6,000 MW of conventional generation in New York City would need to be retained in order to maintain reliability within applicable criteria. Also, the analysis showed over 24,000 MW of conventional generation would be needed statewide.

The 70 x 30 transmission security results reported in the RNA focused on steady state thermal loading of the bulk system. Appendix XX provides the details of the 70 x 30 dynamics analysis. No dynamics criteria violations were observed for the dynamics transmission security analysis when considering the retention of conventional generation.

With the planned increased to renewable energy resources on the system, there are several important considerations to evaluate in addition to traditional steady state and dynamics analysis. It is expected that many renewable generators will be connected to the grid asynchronously through power electronic devices (*i.e.*, inverter-based resources). The ability of inverter-based resources to function properly often depends on the strength of the grid at or near the interconnection of the resources. Grid strength is a commonly used term to describe how the system responds to system changes (*e.g.*, changes in load, and equipment switching). In a “strong” system, the voltage and angle are relatively insensitive to changes in current injection from the inverter-based resource. Inverter-based resources connecting to a portion of the system rich in synchronous generation that is electrically close or relatively large is likely connecting to a strong system. Inverter-based resources connected to a “weak” portion of the grid may be subject to instability, adverse control interactions, and other issues.²⁰

The prevailing measure of system strength is the short-circuit ratio calculation. Short-circuit ratio is defined as the ratio of short-circuit apparent power (SCMVA) at the point of interconnection Point Of Interconnection (POI) from a three-phase fault at the POI to the power rating of the resource. A typical threshold for identifying weak system strength is a short-circuit ratio of 3.0.²¹ **Figure 23** highlights potential weak areas of the system (buses 115 kV and greater) under peak load conditions. Additional details are provided in Appendix XX.

²⁰ North American Electric Reliability Corporation, Integrating Inverter-Based Resources into Low Short Circuit Strength Systems Reliability Guideline, dated December 2017.

²¹ North American Electric Reliability Corporation, Short-Circuit Modeling and System Strength, dated February 2018.

Figure 23: 70 x 30 Short-Circuit Ratio (Peak Load)²²

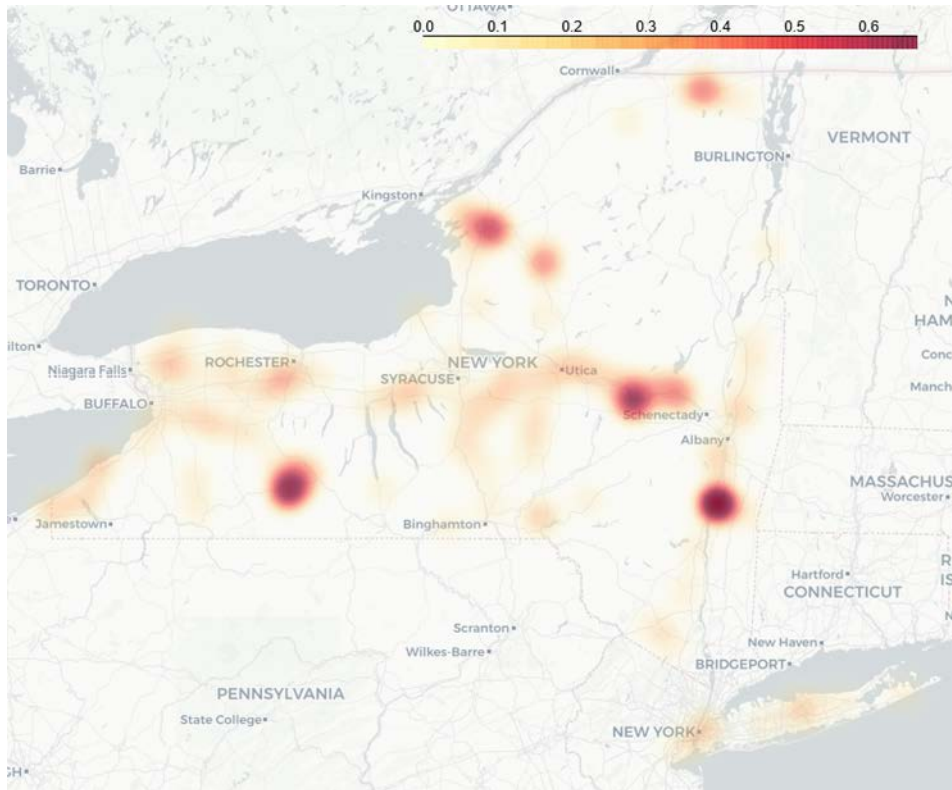

²² The plot scale is the inverse of the short-circuit ratio to highlight the areas of lowest short-circuit strength

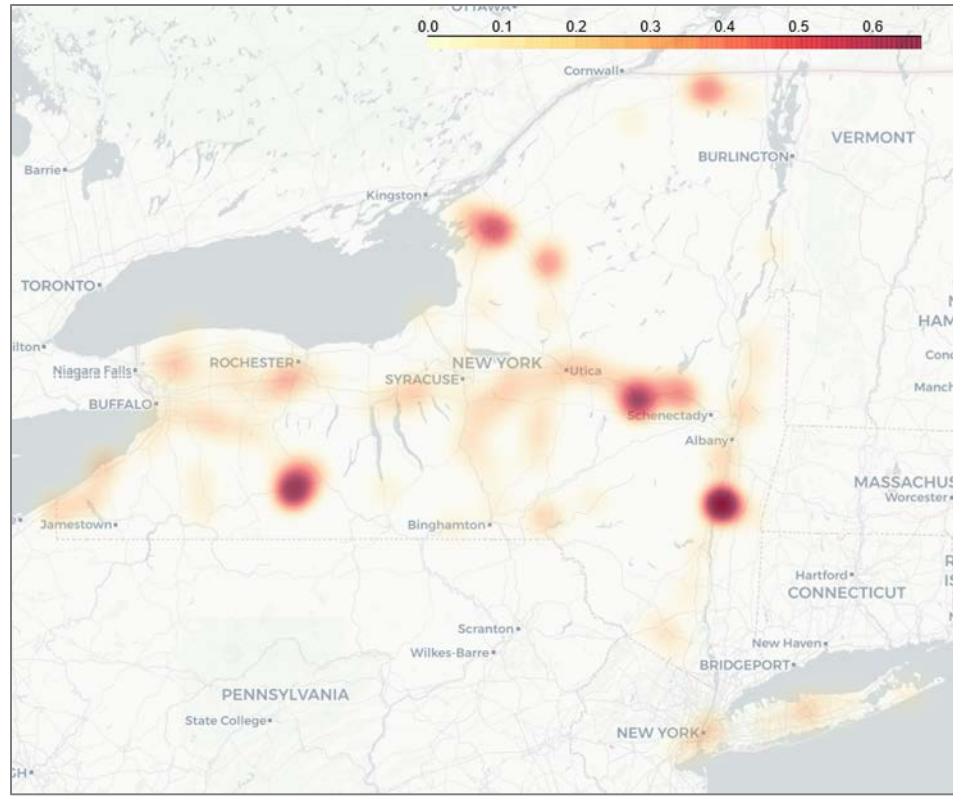

Another measure of system strength is light flicker caused by the connection of large reactive devices (such as a shunt reactive device or a load). Some [NYNew York](#) Transmission Owners have flicker (or Delta-V) criteria. For example, Avangrid criteria for voltage flicker is a change of 3% in bus voltage.²³ **Figure 24** shows the areas of the NYCA (buses 115 kV and greater) that are more susceptible to voltage flicker. Additional details are provided in Appendix XX.

²³ [Avangrid Electric Transmission Planning Manual](#), Technical Manual TM 1.2.00, dated June 29, 2019.

Figure 24: 70 x 30 Peak Load Voltage Flicker²⁴

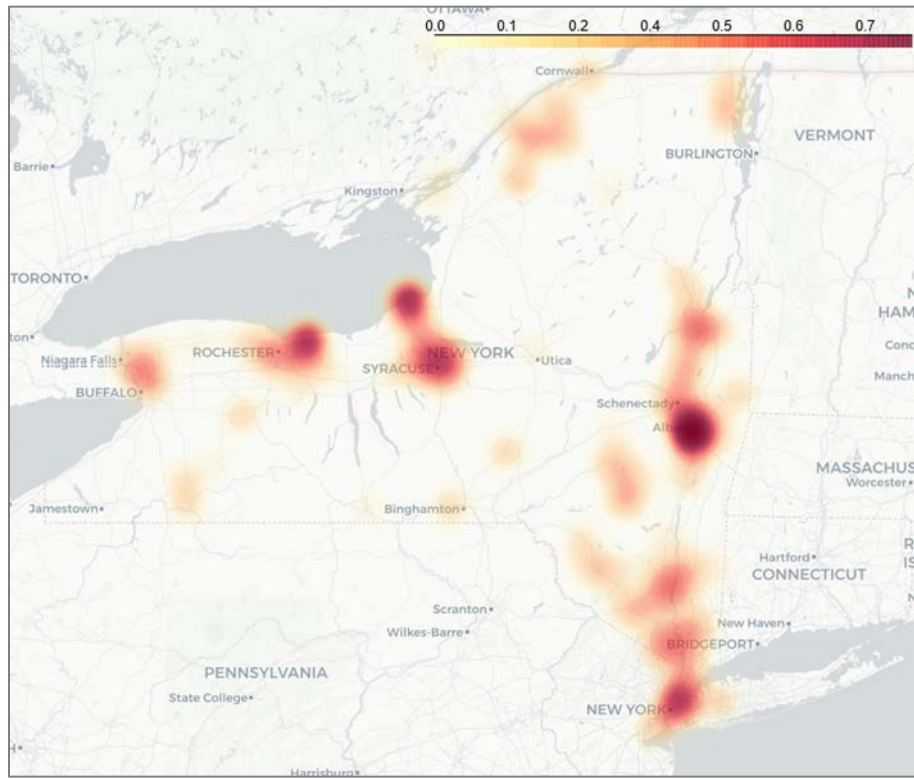

Moving to 2040, the CLCPA requires generation to be emission-free. The [Climate Change Phase II study](#) looked at 100 byx 40 (carbon free electricity to New York consumers by 2040). It noted the significant amount of dispatchable resources that would be needed to meet that goal, but did not describe the technology that would be able to provide a dispatchable resource, instead choosing to refer to generic dispatchable, emission-free resources. Not surprisingly, the Climate Change report found that a similar amount of dispatchable resources as the RNA case would be needed to maintain reliability under baseline assumptions. **However, under CLCPA assumptions, the amount of dispatchable emission-free resources needed increases to approximately 35,000 MW.** The Climate Change Study noted that the current system is heavily dependent on existing fossil-fueled resources to maintain reliability, and eliminating these resources from the mix “will require an *unprecedented level of investment in new and replacement infrastructure, and/or the emergence of a zero-carbon fuel source for thermal generating resources*” (emphasis added)²⁵. The Climate Change Phase II study did note that while the amount of

²⁴ In the plot scale, a 0 represents no change in per-unit voltage and a 1 represents a 0.03 per-unit voltage decline

²⁵ Page 13 of the *Climate Change Impact and Resilience Study – Phase II*
<https://www.nyiso.com/documents/20142/10773574/NYISO-Climate-Impact-Study-Phase-2-Report.pdf>

installed capacity (MW) of dispatchable resources is significant, the amount of energy generated (MWh) required from such resources would likely not be significant, with the percent of total energy being in the range of 10% – 20% range depending on the penetration level of intermittent resources.

The report “*Pathways to Carbon-Neutral NYC*,”²⁶ issued April 2021²⁶ stated “Both low carbon gas and battery storage can supply dispatchable electricity to the grid. However, both technologies are untested at the scale required to deeply decarbonize the city. Batteries are limited by the amount of energy that they can store and how fast that energy can be discharged. Batteries also require capital to build and space to occupy. At the same time, low carbon gas availability is uncertain, and there is no policy framework to develop these resources at scale. While maintaining gas-fired electricity generation assets can avoid new capital expenditures, sources of ~~renewable natural gas~~ RNG Renewable Natural Gas (RNG) would need to be connected to the existing pipeline gas transmission and distribution system, requiring investments. Additionally, RNG combustion still generates air pollutant emissions, which must be considered (emphasis added).”

The NYISO [Grid in Transition](#) study noted that it is generally recognized today that meeting New York load with high levels of intermittent resource output, particularly solar and wind generation, will require the NYISO to have sufficient flexible, dispatchable and potentially fast ramping supply to balance variations in intermittent resource output. These variations will include not only short-term variations in output during the operating day as a result of changes in wind speed and cloud cover but also a sustained ramp up of solar output at the beginning of the day as the sun rises and a sustained ramp down of solar output at the end of the day as the sun sets. The Climate Change Phase II study noted in the winter under the CLCPA scenario that the one-hour ramp requirements could be over 10,000 MW and a six-hour ramp of over 25,000 MW, as noted in the graph below.

²⁶ Commissioned by the NYC Mayor’s Office of Sustainability (MOS), Con Edison, and National Grid: [\[link\]](#)

Figure 25: Maximum Hourly Ramping Requirement - Winter CLCPA Load Scenario, Baseline Case

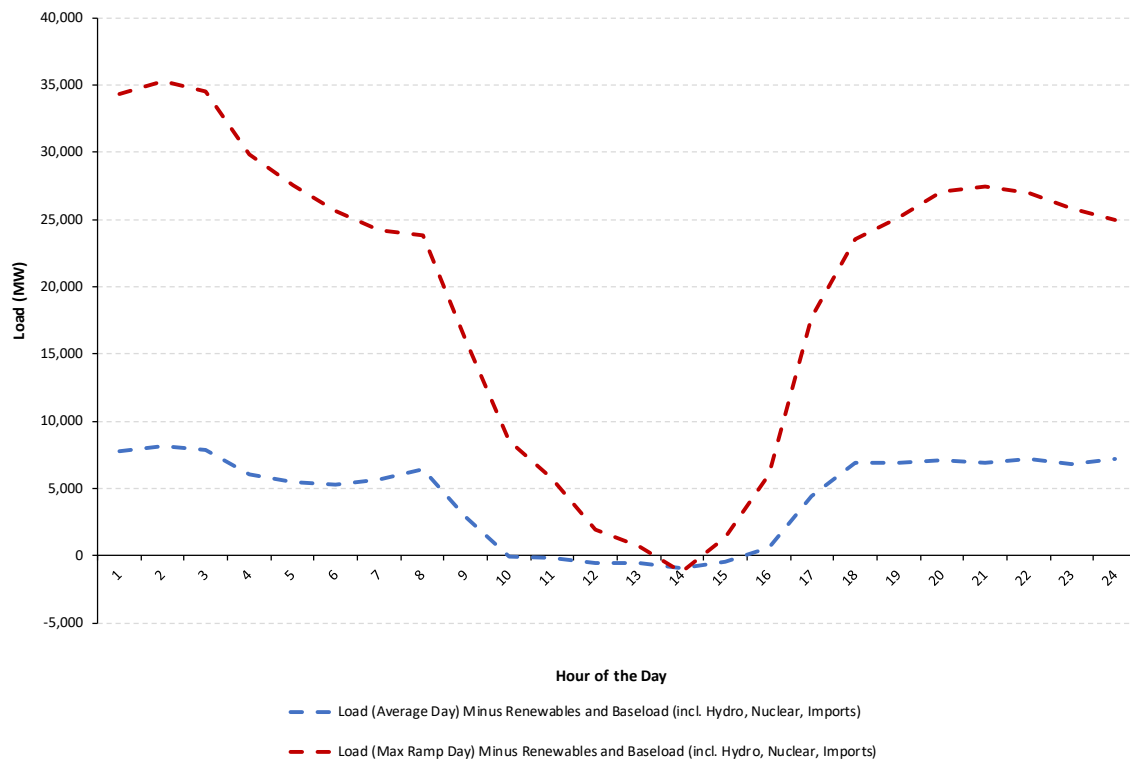

One last point bears noting: While there are hundreds of projects in the NYISO interconnection queue, there are none that would be capable of providing emission-free, dispatchable resources that could perform on a multi-day period to maintain bulk power system reliability. Such resources are not yet widely commercially available.

Key takeaways

- A system with significant amounts of intermittent resources will need significant amounts of dispatchable resources that can run for multiple day periods.
- Due to the characteristics of sun and wind resources, there will be high ramping requirements needed from the dispatchable resources.
- A 100 x 40 power system will require those dispatchable resources to be emissions-free
- Dispatchable resources that are emissions-free, and on the scale needed, are not yet ~~tested~~ available or currently in the NYISO interconnection queue.

Transmission

Transmission will play a key role in moving power from where the intermittent resources are located to the load centers.

The build out of transmission can be broken down into two components. ~~The first is inter;~~

~~1. Inter-zonal bulk power capability and the second is intra~~

~~1-2. Intra-zonal local transmission capability~~

The NYISO has moved forward with two Public Policy Transmission projects. One in the west that will provide capability to move Niagara hydro generation and Ontario renewable resource imports out of the western area of the state to serve load areas in the eastern and southern portions of New York. The second project moves power from upstate to the southeast part of the state by replacing and adding transmission lines in the Mohawk River Valley and the Hudson River Valley.

Additionally, the 2020 New York State Accelerated Renewable Energy Growth and Community Benefit Act (AREA), ~~enacted in 2020,~~ seeks to accelerate siting and construction of large-scale clean energy projects.²⁷ The AREA authorized the New York Power Authority (NYPA) to undertake the development of transmission investments needed to achieve CLCPA targets. On October 15, 2020, the PSC adopted criteria for designating priority transmission projects. The PSC also approved NYPA's request to proceed with development of its proposed Northern New York Transmission Projects.²⁸ These transmission upgrades seek to increase the capacity of certain transmission lines in northern New York to accommodate incremental delivery of renewable energy. Under the new law the New York Public Service Commission authorized NYPA to pursue construction of its proposed Northern New York transmission expansion project. The project will increase the capacity of transmission lines in northern New York.

²⁷ 2020 Laws of N.Y. Ch. 58, Part JJJ.

²⁸ PSC Case 20-E-0197, Proceeding on Motion of the Commission to Implement Transmission Planning Pursuant to the Accelerated Renewable Energy Growth and Community Benefit Act, *Order on Priority Transmission Projects* (October 16, 2020).

These new transmission investments are depicted in the map below.

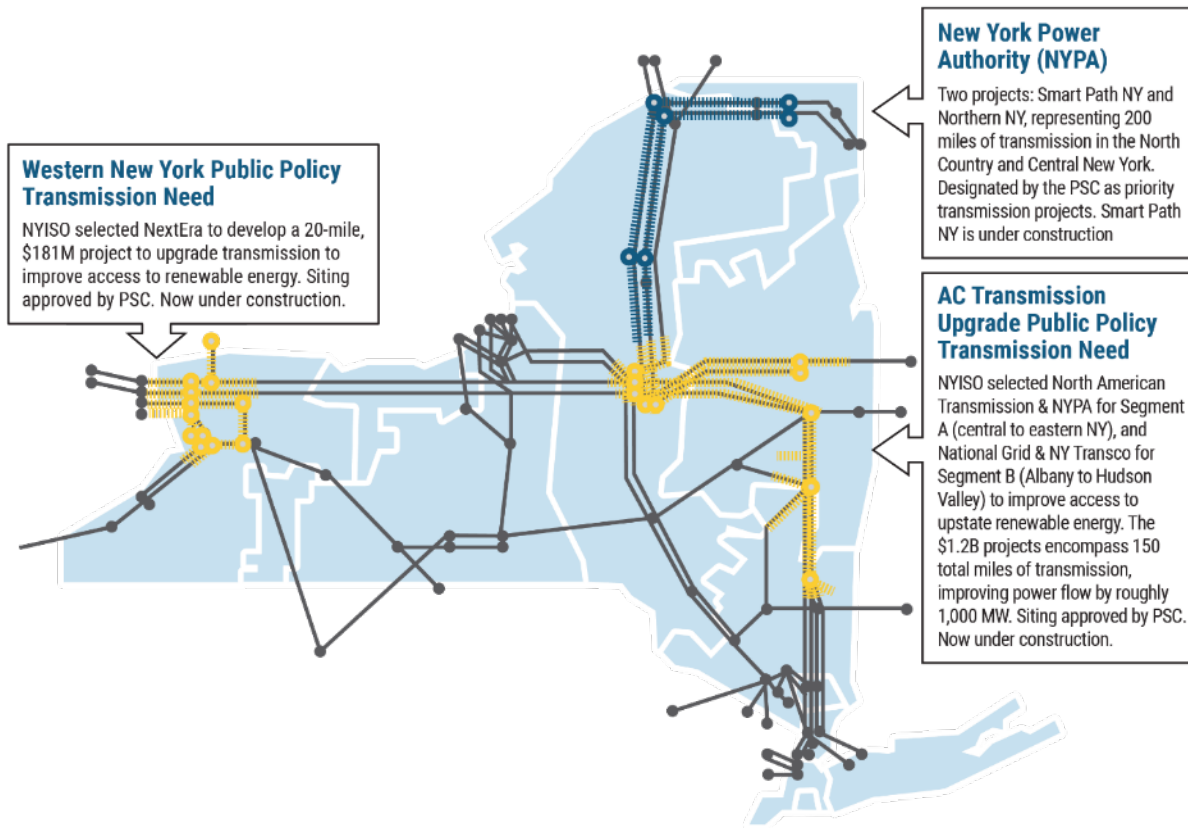

The ~~2019 CARIS~~ 2019 CARIS study noted several renewable generation pockets on the ~~115kV/138kV~~ 115 kV/138 kV systems across the whole state that could constrain output from renewable resources such as solar and wind. These include Western New York, the North Country, Capital Region, Southern Tier, and ~~Offshore Wind~~ offshore wind near Long Island and New York City. ~~These generation pockets are depicted in the map below.~~

These generation pockets are depicted in the map below:

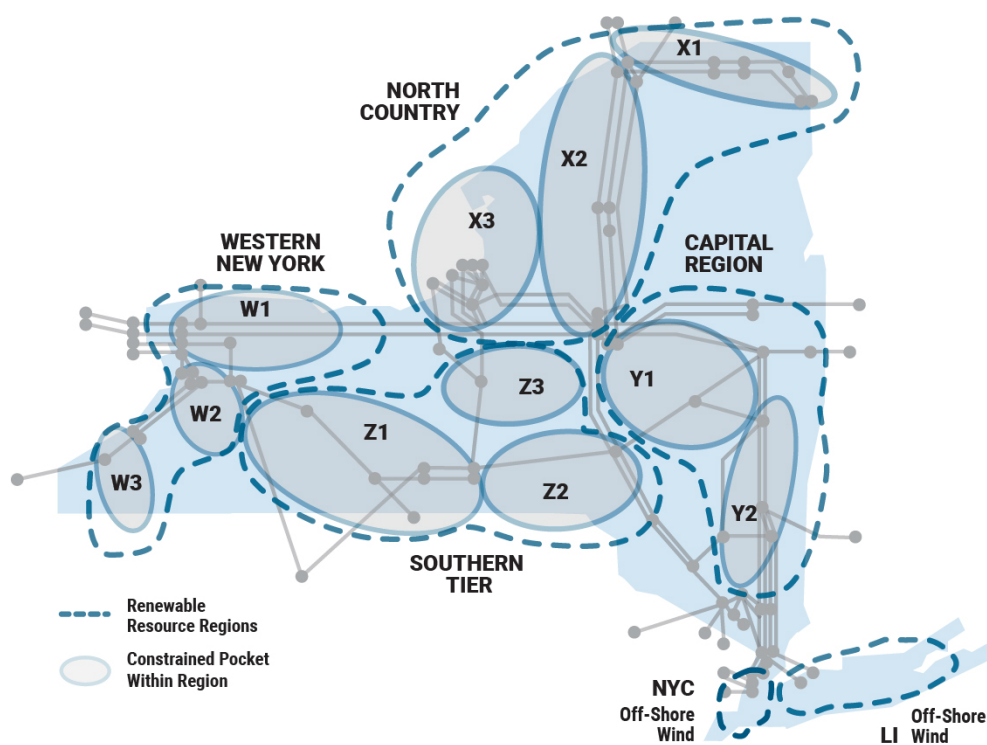

[DPS and NYSERDA's Initial Power Grid Study](#), released in January 2021, concluded that the transmission system, with the inclusion of the Western New York and AC Transmission public policy transmission projects and the NYPA priority projects, [along with the utilities' planned local transmission and distribution system](#), have positioned the state to achieve the 70 x 30 renewable energy requirements of the CLCPA without the need for further additional transmission capability. The report indicated that additional [bulk](#) transmission will be needed to achieve the CLCPA's objective of a zero-emissions electric system by 2040. The Initial Power Grid Study indicated that transmission upgrades would also be needed to deliver the 9,000 MW of offshore wind capacity called for in the CLCPA.

In its comments on the study, the NYISO highlighted the need for additional transmission investment to achieve the 70 x 30 goal based on the expected location of renewable resources within the state. The NYISO also commented on the electric utilities' November 2020 local transmission and distribution study, emphasizing the role that building out bulk and local transmission systems can play in delivering land-based and offshore wind renewable resources to consumers to meet the state's climate change policy objectives.²⁹ The NYISO emphasized the need for transmission to deliver renewable energy to consumers, suggesting that the PSC declare transmission needs for delivery of land-based renewable resources in

²⁹ See <https://www.nyiso.com/documents/20142/18663846/20210119-NYISOCCommentsCase20E0197-complete.pdf>

upstate New York renewable generation pockets and for offshore wind resources to connect to Long Island and New York City. The NYISO noted that its streamlined competitive public policy transmission process is well positioned to fulfill those needs for the state.³⁰

In March 2021, the PSC issued an order declaring that offshore wind goals are driving the need for additional transmission facilities to deliver that renewable power from Long Island to the rest of New York State. The PSC referred the identified need to the NYISO to solicit potential solutions.³¹

The NYISO will solicit proposed solutions, determine their viability and sufficiency, and evaluate potential solutions to determine whether to select the more cost-effective or efficient transmission project to satisfy the PSC-identified need. As with the projects discussed above, any project selected through this process will be subject to the PSC-administered permitting process before construction is allowed to begin.

One last point bears emphasizing on the role of transmission: While increased transmission can allow more renewable resources to connect the grid, the amount of capacity (MW) of dispatchable resources needed for reliability may not reduce significantly. However, the amount of energy (MWh) from renewable resources can significantly increase with more renewable resources and transmission.

Key takeaways

- More inter- and intra- zonal transmission capacity will be required to deliver a reliable system with a high level of renewables penetration.
- Transmission additions would not reduce the amount of dispatchable resource capacity but would decrease the amount of energy needed from them.

³⁰ See <https://www.nyiso.com/documents/20142/18663846/20210119-NYISOCCommentsCase20E0197-complete.pdf>

³¹ Case No. 20-E-0497 and Case No. 18-E-0623, Order Addressing Public Policy Requirements for Transmission Planning Purposes (March 19, 2021).

Market Design for a Grid ~~In~~ Transition [New Section]

The New York grid is facing an unprecedented transition as the state's generation transitions to the CLCPA mandate that 70% of New York State's end-use energy be generated by renewable energy systems by 2030 ("70x30") and the target of an emission-free resource mix by 2040. The market design challenge when faced with a grid transitioning from the existing fleet to one where load is predominantly met with intermittent power resources is to make needed market rule and design changes before, they are needed so that investments in all areas including in generation, transmission, and the distribution system, are consistent with the reliability needs and the cost to consumers is minimized.

As discussed earlier in this report, as the level of intermittent resource generation increases, the grid will need sufficient flexible and dispatchable resources to balance variations in intermittent resource output for both short durations as a result of cloud cover or changes in wind speed, and prolonged periods (daily/seasonally) of renewable output lulls. Over the next several years, market projects will continue to address the changes needed in the energy and ancillary services as well as prepare the markets for new resource classes. These efforts will focus on improving signals for the characteristics and attributes needed for continued grid reliability with increasing amounts of intermittent resource generation. Improving the energy and ancillary service market design is crucial for proper wholesale electricity market price formation that signals the investment and dispatch behavior needed to maintain grid reliability, properly value locational grid needs, incent attributes valuable to the grid, and avoid unnecessary out-of-market actions.

As the resource mix shifts, it is crucial to address the challenge of efficient resource entry and exit to meet policy objectives, while continuing to attract/retain resources necessary to meet established resource adequacy requirements. The NYISO is focused on a holistic review of the current mitigation framework in order to mitigate or eliminate unnecessary risk of buyer-side mitigation (BSM) for resources necessary to achieve the CLCPA's objectives and improve transparency and certainty on the impact BSM will have on new resources entering the wholesale market. Any process changes that are ultimately developed will need to be just and reasonable and allow the ICAP Market to continue to attract and retain resources needed to maintain resource adequacy.

It is also imperative to value capacity resources accurately based on their contributions to resource adequacy. This allows market compensation for capacity suppliers to be properly aligned with individual resources' expected reliability benefit to consumers while ensuring sufficient resources are procured to meet resource adequacy requirements.

The NYISO is actively preparing for the resource changes and their operational and reliability implications and will continue to work with stakeholders on evolving the market design to ensure it provides clear signals for the attributes and services needed to support grid reliability.

Recommended Actions and Conclusions

The 2021-2030 Comprehensive Reliability Plan shows no Bulk Power Transmission Facility Reliability Needs and, therefore, no additional solutions are necessary. Nevertheless, the Comprehensive Reliability Plan contains the following recommendations based on risks to bulk power system reliability:

Monitor and Track Potential New Developments

The energy industry is in transition. Economic conditions, governmental programs and environmental regulations are changing quickly, resulting in financial stresses that may lead to the loss of resources or, alternatively, that could positively affect system conditions. New market-based generation and transmission projects under study in the NYISO's interconnection process could increase the reliability margin of the electric system in the long term, if such capacity comes into service during the Study Period. The NYISO will monitor and track these developments and consider their potential impacts on future system reliability. The NYISO will administer its Short-Term Reliability Process to address Generator Deactivation Notices and other system changes on a quarterly basis. The NYISO will continuously evaluate a forward-looking five-year period, and, if necessary, seek solutions. In addition, if a threat to reliability appears to be imminent, the NYISO may request immediate solutions outside of the normal planning cycle, in accordance with its tariffs and procedures.

Monitor and Track Transmission Owner Plans

To provide for the long-term reliability of the system and minimize reliance on interim operating procedures, the Transmission Owners need to complete the projects identified in their Local Transmission Owner Plans ([LTPs](#)) on schedule and as planned. It is important that the local transmission projects that are identified in this CRP to maintain reliability be sited and constructed on a timely basis. The NYISO will continue to monitor the completion of the identified projects and the progress of local transmission projects as they relate to the Reliability Needs initially identified in the Reliability Needs Assessment.

These include the following:

- Updated Local Transmission Owner Plans ([LTPs](#)) as presented by Con Edison at the January 25, 2021 ESPWG/TPAS [\[link\]](#):
 - A new 345/138 kV PAR controlled 138 kV Rainey – Corona feeder (ISD 2023)
 - A new 345/138 kV PAR controlled 138 kV Gowanus – Greenwood feeder (ISD 2025)
 - A new 345/138 kV PAR controlled 138 kV Goethals – Fox Hills feeder (ISD 2025)
- Short Term Reliability Process solution for addressing the 2023 short-term need identified in the Q3-2020 STAR [\[link\]](#). The solution changed the planned operating status of existing series

reactors, starting summer 2023 through 2030:

- In-service: series reactors on the following 345 kV cables: 71, 72, M51, M52
 - Bypass: series reactors on the following 345 kV cables: 41, 42, Y49
- Transient voltage response issues were observed on Con Edison’s non-BPTF system from 2025 through 2030, while the BPTF violations were observed starting in 2029. Con Edison will address the non-BPTF violations with a Corrective Action Plan as required by NERC Standard TPL-001-4. When the non-BPTF violations are addressed, the BPTF violations will no longer occur. [link]

Continue Coordination with the New York State Public Service Commission

The NYISO will continue to coordinate its system planning activities with the PSC, particularly as part of the Public Policy Transmission Planning Process that is addressing transmission needs in Western New York, the Mohawk Valley and Hudson Valley transmission corridors, and for integration of offshore wind as part of the NYISO’s overall Comprehensive System Planning Process ~~(CSPP)~~. If the PSC determines that there is an additional Public Policy Requirement that is driving the need for bulk transmission, the NYISO will solicit projects from developers to fulfill that need.

In addition, the State of New York is presently considering expanding and extending a variety of clean energy programs that are designed to increase deployment of energy efficiency, renewable generation and DERs. Existing energy efficiency, codes and standards, distributed generation and solar (behind-the-meter) program initiatives are reflected in the load forecast and resources modeled in this CRP. However, there are new initiatives that have not been implemented yet or recognized in this Reliability Planning Process cycle that could positively affect bulk power system reliability. The NYISO will continue to monitor and participate in other planning activities including, but not limited to, PSC proceedings considering: ~~(i1)~~ fulfilling the requirements of the Climate Leadership and Community Protection Act (CLCPA), ~~(ii2)~~ implementation of the Accelerated Renewable Energy and Community Benefit Act (AREA), ~~(iii3)~~ Reforming the Energy Vision (REV), ~~(iv4)~~ Offshore Wind Standard and procurements, ~~(v5)~~ Renewable Energy Credits (RECs), ~~(vi)~~ including Tier 4 RECs, ~~(6)~~ Zero-Emission Credits (ZECs), ~~(vii)~~ distributed energy resources ~~7)~~ Distributed Energy Resources (DERs), ~~(viii)~~ energy storage resources ~~8)~~ Energy Storage Resources (ESRs), ~~(ix9)~~ energy efficiency, and ~~(x10)~~ individual proceedings on transmission siting and generation deactivation and repowering.

Monitor Changes That Could Impact Risk Factors

The NYISO actively monitors and addresses the potential impacts of known risk factors. ~~The NYISO also~~ As well as tracks the impact that new market-based generation projects under study in the NYISO’s

interconnection process could have on the NYISO's long-term capacity margin during the ~~ten~~10-year Study Period.

As discussed in this report, the NYISO has also performed a scenario simulating deactivations of simple cycle combustion turbines that could be impacted by the DEC's Peaker Rule. The NYISO will continue to monitor the progress of DEC emission rules and their impacts on New York resources. The NYISO's 2022-2023 cycle of the Reliability Planning Process will consider any additional changes to generator compliance plans for the Peaker Rule³² to establish the baseline system conditions for the 2023-2032 planning horizon. Also, the NYISO will continue to implement the Short-Term Reliability Process by conducting quarterly Short-Term Assessments of Reliability (STARs) and addressing reliability issues identified for following five years, with an emphasis on reliability needs arising in years one through three. The NYISO will address Generator Deactivation Notices, other generator unavailability, and other system changes affecting the power system reliability, as part of the Short-Term Reliability Process.

Future NYISO studies

Quarterly STAR—: The NYISO will administer its quarterly STAR through the Short-Term Reliability Process to capture events such as generator deactivations and other system changes. Through the Short-Term Reliability Process, the NYISO will address every quarter Reliability Needs arising within five years, with an emphasis on needs arising in years one through three. If necessary, the NYISO will seek solutions to address any Reliability Needs identified through that process. For generators affected by the Peaker Rule, the NYISO could enter into Reliability Must Run agreements with specific generators to continue to operate for a two-year period, with a possible two-year extension, until market-based projects or permanent transmission solutions are built. Moreover, the NYISO continuously monitors all planned projects and any changes to the New York State transmission system, and may request solutions outside of its normal planning cycle if there appears to be an imminent threat to the reliability of the bulk power transmission system arising from causes other than deactivating generation.

2022 RNA—: The next cycle of the Reliability Planning Process will begin in 2022, for which preparations will begin in late 2021. The 2022 RNA will provide a new reliability assessment of the New York Bulk Power Transmission Facilities for years four through ten of the planning horizon s (2026 through 2032). The 2022 RNA will be based on updated data, system models and assumptions, and will review the status of the risk factors discussed in this CRP, together with other reliability issues.

System & Resource Outlook—: Following FERC approval of significant improvements to the Economic

³² <https://www.dec.ny.gov/regulations/116131.html>

Planning Process, the NYISO is currently undertaking a new 20-year System & Resource Outlook for the first time, to be issued in 2022. The Outlook will provide a comprehensive overview of system resources and likely transmission constraints throughout New York, thus highlighting opportunities for transmission investment driven by economics and public policy.

Together, the Comprehensive Reliability Plan and the System & Resource Outlook will be the marquee NYISO planning reports that will collectively provide a comprehensive power system outlook to investors, developers and policymakers every year.

2021-2030 CRP APENDICES

Appendix A – Glossary **[New Section]**

The following glossary offers definitions and explanations of terms used in the Comprehensive Reliability Plan it appends, as well as references to additional source information published by the NYISO and other energy industry entities.

Annual Transmission Reliability Assessment (ATRA): An assessment, conducted by the NYISO staff in cooperation with Market Participants, to determine the System Upgrade Facilities required for each generation project and Class Year Transmission Project to interconnect to the New York State Transmission System in compliance with Applicable Reliability Standards and the NYISO Minimum Interconnection Standard. See NYISO OATT

Area Transmission Review (ATR): An annual report provided to the Northeast Power Coordinating Council Compliance Committee by the NYISO, in its role as Planning Coordinator, in regard to its Area Transmission Review. See NPCC.org

Baseline Forecast: Prepared for the NYISO Gold Book, baseline forecasts report the expected New York Control Area load and include the projected impacts of energy efficiency programs, building codes and standards, distributed energy resources, behind-the-meter energy storage, behind-the-meter solar photovoltaic power, electric vehicle usage, and electrification of heating and other end uses. The baseline forecasts are used in the Reliability Needs Assessment Base Cases for determining Bulk Power Transmission Facilities Reliability Needs for the Reliability Needs Assessment Study Period.

Best Technology Available (BTA): Performance goal established by the New York State Department of Environmental Conservation for cooling water intake structures at proposed and existing electric generating plants with intake capacity greater than 20 million gallons per day. See DEC.NY.gov

New York State Bulk Power Transmission Facility (BPTF): Facilities identified as the New York State Bulk Power Transmission Facilities in the annual Area Transmission Review submitted to the Northeast Power Coordinating Council by the NYISO. See NYISO OATT

Clean Energy Standard (CES): New York State initiative requiring 70% of electricity consumed in the State to be produced from renewable sources by 2030. See NYSERDA.NY.gov

Climate Leadership and Community Protection Act (CLCPA): New York State statute enacted in 2019 to address and mitigate the effects of climate change. Among other requirements, the law mandates that; (i) 70% of energy consumed in New York State be sourced from renewable resources by 2030, (ii) greenhouse gas emissions must be reduced by 40% by 2030, (iii) the electric generation sector must be zero greenhouse gas emissions by 2040, and (iv) greenhouse gas emissions across all sectors of the economy must be reduced by 85% by 2050. See CLIMATE.NY.gov

Contingencies: Actual or potential unexpected failure or outage of a system component such as a generator, transmission line, circuit breaker, switch, or other electrical element. A contingency also may include multiple components, which are related by situations leading to simultaneous component outages. See NYSRC.org

Dependable Maximum Net Capability (DMNC): Sustained maximum net output of a Generator, as demonstrated by the performance of a test or through actual operation, averaged over a continuous time period. See NYISO OATT

Disturbance – Severe oscillations or severe step changes of current, voltage and/or frequency usually caused by faults. See NYSRC.org

Electric System Planning Work Group (ESPWG): The stakeholder forum that provides Market Participant input on the NYISO’s comprehensive system planning processes. See Committees at NYISO.com

Emergency Transfer Criteria: In the event that adequate facilities are not available to supply firm load within Normal Transfer Criteria, emergency transfer criteria may be invoked. Under emergency transfer criteria, transfers may be increased up to, but not exceed, emergency ratings and limits, as follows:

- a. Pre-contingency line and equipment loadings may be operated up to LTE ratings for up to four (4) hours, provided the STE ratings are set appropriately. Otherwise, pre-contingency line and equipment loadings must be within normal ratings. Pre-contingency voltages and transmission interface flows must be within applicable pre-contingency voltage and stability limits.
- b. Post-contingency line and equipment loadings within STE ratings. Post-contingency voltages and transmission interface flows within applicable post-contingency voltage and stability limits. See NYSRC.org

Fault: An electrical short circuit. See NYSRC.org

Federal Energy Regulatory Commission (FERC): The United States federal agency that regulates the transmission and wholesale sale of electricity and natural gas in interstate commerce.

FERC Form No. 715: Annual report by transmitting utilities on transmission planning, constraints and available transmission capacity. See FERC.gov

Forced Outage: Unscheduled inability of a Market Participant’s Generator to produce Energy that does not meet the notification criteria to be classified as a scheduled outage or de-rate as established in NYISO Procedures. See NYISO.com

Gold Book: Annual NYISO publication, also known as the Load and Capacity Data Report. See Library/Reports at NYISO.com

Installed Capacity (ICAP): External or Internal Capacity that is made available pursuant to Tariff requirements and NYISO Procedures. See NYISO Services Tariff

Installed Capacity Requirement (ICR): The annual statewide requirement established by the New York State Reliability Council in order to provide resource adequacy in the New York Control Area. See NYSRC.org

Installed Reserve Margin (IRM): The amount of installed electric generation capacity above 100% of the forecasted peak electric demand that is required to meet New York State Reliability Council resource adequacy criteria.

Local Transmission Plan (LTP): The Local Transmission Owner Plan, developed by each Transmission Owner, which describes its respective plans that may be under consideration or finalized for its own Transmission District. See NYISO OATT

Local Transmission Planning Process (LTPP): The Local Planning Process conducted by each Transmission Owner for its own Transmission District. See NYISO OATT

Loss of Load Expectation (LOLE): A New York State Reliability Council resource adequacy criterion requiring that the probability (or risk) of the unplanned disconnecting of any firm load due to resource deficiencies

shall be, on average, not more than once in ten years, expressed mathematically as 0.1 days per year. See NYSRC.org

Market Monitoring Unit: The consulting or professional services firm, or other similar entity, responsible for carrying out the Core Market Monitoring Functions and other functions assigned to it in the NYISO's tariffs. . See NYISO OATT Attachment O

Market Participant: An entity, excluding the NYISO, that produces, transmits, sells, and/or purchases for resale unforced capacity, energy or ancillary services in the wholesale market, including entities that buy or sell Transmission Congestion Contracts. See NYISO Services Tariff

Market Administration and Control Area Services Tariff (NYISO Services Tariff): The document addressing the Market Services and the Control Area Services provided by the NYISO, and the terms and conditions, regulated by the FERC, under which those services are provided.

New York Control Area (NYCA): The area under the electrical control of the NYISO, including the entire state of New York, divided into eleven load zones. See NYISO.com

New York State Department of Environmental Conservation (NYSDEC): The agency that implements the New York State Environmental Conservation Law, with some programs also governed by federal law.

New York Independent System Operator (NYISO): A not-for-profit organization that operates New York's bulk electricity grid, wholesale electricity markets and conducts interconnection and transmission planning.

NYISO Procedures (Manuals, Guides, Technical Bulletins): NYISO Manuals specify and explain the procedures and policies used to operate the bulk power system of the New York Control Area and to conduct wholesale electricity markets, consistent with the NYISO Tariffs and Agreements. NYISO Guides serve to assist users with information needed to participate in NYISO Administered Markets. NYISO Technical Bulletins explain changes to, and provide instruction for, NYISO processes and procedures. See NYISO.com

New York State Department of Public Service (NYDPS): The New York State agency that supports the New York State Public Service Commission. See DPS.NY.gov

New York State Energy Research and Development Authority (NYSERDA): The New York State public authority charged with conducting a multifaceted energy and environmental research and development program to meet New York State's diverse economic needs, including administering the state System Benefits Charge, Renewable Portfolio Standard, energy efficiency programs, the Clean Energy Fund, and the NY-Sun Initiative. See NYSERDA.NY.gov

New York State Public Service Commission (NYPSC): The decision-making body of the New York State Department of Public Service, which regulates the state's electric, gas, steam, telecommunications, and water utilities, oversees the cable industry, has the responsibility for setting rates and overseeing that safe and adequate service is provided by New York's utilities, and exercises jurisdiction over the siting of major gas and electric transmission facilities.

NY-Sun Initiative: A program run by NYSEDA for the purpose of obtaining more than 6,000 MW-DC of behind-the-meter solar photovoltaic systems by the end of 2023. See NYSEDA.NY.gov

New York State Reliability Council (NYSRC): A not-for-profit entity the mission of which is to annually establish the Installed Reserve Margin, and to promote and preserve the reliability of electric service on the New York State Power System by developing, maintaining, and updating the Reliability Rules with which the NYISO and

all entities engaging in electric transmission, ancillary services, energy and power transactions on the New York State Power System must comply. See NYSRC.org

Normal Transfer Criteria: Measures established, in accordance with the North American Electric Reliability Corporation, Northeast Power Coordinating Council, and the New York State Reliability Council's Reliability Rules, to determine that adequate facilities are available to supply firm load in the bulk power transmission system within applicable normal ratings and limits. See NYSRC.org

Normal Transfer Limit: The lowest limit based on the most restrictive of three maximum allowable transfers, calculated based on thermal, voltage, and stability testing, considering contingencies, ratings, and limits specified for normal conditions. See NYSRC.org

North American Electric Reliability Corporation (NERC): A not-for-profit international regulatory authority the mission of which is to assure the effective and efficient reduction of risks to the reliability and security of the grid. See NERC.com

Northeast Power Coordinating Council (NPCC): The entity to whom the North American Electric Reliability Corporation has delegated Electric Reliability Organization functions in the New York Control Area. See NYISO OATT

Open Access Transmission Tariff (OATT): The document setting forth the rates, terms and conditions, accepted or approved by the FERC, under which the NYISO provides transmission service and conducts interconnection and transmission system planning.

Order No. 890: Order issued by the FERC in 2007 that amended the regulations and the *pro forma* open access transmission tariff to provide that transmission services and planning are provided on a basis that is just, reasonable and not unduly discriminatory or preferential. See FERC.gov

Order No. 1000: Order issued by the FERC in 2011 that amended the transmission planning and cost allocation requirements established in Order No. 890 to provide that Commission-jurisdictional services, including transmission planning, are provided at just and reasonable rates and on a basis that is just and reasonable and not unduly discriminatory or preferential. See FERC.gov

Outage: The forced or scheduled removal of generating capacity or a transmission line from service.

Peak Demand: The maximum instantaneous power demand, measured in megawatts (MW), and also known as peak load, is usually measured and averaged over an hourly interval. The peak hour is the hour during which the coincident usage was the highest across the entire New York Control Area in a given time period.

Queue Position: The order, in the NYISO's Interconnection Queue, of a valid Interconnection Request, Study Request, or Transmission Interconnection Application relative to all other pending Requests. See NYISO OATT

Rating: The operational limits of an electric system, facility, or element under a set of specified conditions. Rating categories include Normal Rating, Long-Term Emergency (LTE) Rating, and Short-Term Emergency (STE) Rating, as follows:

- i. *Normal Rating:* The capacity rating of a transmission facility that may be carried through consecutive twenty- four (24) hour load cycles.
- ii. *Long Time Emergency (LTE) Rating:* The capacity rating of a transmission facility that can be carried through infrequent, non- consecutive four (4) hour periods.

iii. **Short Time Emergency (STE) Rating:** The capacity rating of a transmission facility that may be carried during very infrequent contingencies of fifteen (15) minutes or less duration. (Source: NYSRC Reliability Rules). See NYSRC.org

Reasonably Available Control Technology for Major Facilities of Oxides of Nitrogen (NO_x RACT): New York State Department of Environmental Conservation regulations for the control of emissions of nitrogen oxides (NO_x) from fossil fuel-fired power plants. See DEC.ny.gov

Reactive Power: The portion of electric power that establishes and sustains the electric and magnetic fields of alternating-current equipment.

Reactive Power Resources: Facilities such as generators, high voltage transmission lines, synchronous condensers, capacitor banks, and static VAR compensators that provide reactive power.

Regional Greenhouse Gas Initiative (RGGI): A cooperative effort by a group of Northeast and Mid-Atlantic states to limit power sector greenhouse gas emissions using a market-based cap-and-trade approach. See RGGI.org

Reliability: The degree of performance of the bulk electric system that results in electricity being delivered to customers within accepted standards and in the amount desired, which can be addressed by considering the adequacy and security of the electric system:

- i. **Adequacy:** The ability of the electric systems to supply the aggregate electrical demand and energy requirements of their customers at all times, taking into account scheduled and reasonably expected unscheduled outages of system elements. Note: Adequacy encompasses both generation and transmission.
- ii. **Security:** The ability of the electric system to withstand disturbances such as electric short circuits or unanticipated loss of system elements. The ability of the power system to withstand the loss of one or more elements without involuntarily disconnecting firm load. See NYSRC.org

Reliability Criteria: The electric power system planning and operating policies, standards, criteria, guidelines, procedures, and rules promulgated by the North American Electric Reliability Corporation, Northeast Power Coordinating Council, and the New York State Reliability Council. See NYISO OATT Attachment Y

Reliability Need: A condition identified by the NYISO as a violation or potential violation of one or more Reliability Criteria. See NYISO OATT Attachment Y

Reliability Needs Assessment (RNA): A report that evaluates resource adequacy and transmission system security over years four through ten of a 10-year planning horizon, and identifies future needs of the New York electricity grid. It is the first step in the NYISO's reliability planning process. See NYISO OATT Attachment Y

Reliability Needs Assessment (RNA) Study Period: The seven-year time period encompassing years four through ten following the year in which the RNA is conducted, which is used in the RNA and the Comprehensive Reliability Plan. See NYISO OATT Attachment Y

Reliability Planning Process (RPP): The process by which the NYISO determines, in the Reliability Needs Assessment, whether any Reliability Need(s) on the New York State Bulk Power Transmission Facilities will arise in the Study Period, and addresses any identified Reliability Need(s) in the Comprehensive Reliability Plan. See NYISO OATT Attachment Y

Reliability Solutions: Potential solutions to reliability needs include the following:

- i. **Alternative Regulated Solutions (ARS):** Regulated solutions submitted by a Transmission Owner or other developer in response to a solicitation for solutions to a Reliability Need identified in a Reliability Needs Assessment.
- ii. **Gap Solution:** A solution to a Reliability Need that is designed to be temporary and to strive to be compatible with permanent market-based proposals. The NYISO may call for a Gap Solution to an imminent threat to reliability of the Bulk Power Transmission Facilities if no market-based solutions, regulated backstop solutions, or alternative regulated solutions can meet the Reliability Needs in a timely manner.
- iii. **Market-Based Solution:** Investor-proposed project driven by market needs to meet future reliability requirements of the bulk electricity grid as outlined in the Reliability Needs Assessment. These can include generation, transmission, and demand response Programs.
- iv. **Regulated Backstop Solution:** Proposals are required of certain Transmission Owners to meet Reliability Needs as outlined in the Reliability Needs Assessment.

Those solutions can include generation, transmission, or demand response. Non-Transmission Owner developers may also submit regulated solutions. See NYISO OATT Attachment Y

Responsible Transmission Owner (Responsible TO): The Transmission Owner(s) designated by the NYISO to prepare a proposal for a regulated backstop solution to a Reliability Need or to proceed with a regulated solution to a Reliability Need. The Responsible Transmission Owner will normally be the Transmission Owner in whose Transmission District the ISO identifies a Reliability Need and/or that owns a transmission facility on which a Reliability Need arises. See NYISO OATT Attachment Y

Short-Term Assessment of Reliability (STAR): The NYISO's quarterly assessment, in coordination with the Responsible Transmission Owner(s), of whether a Short-Term Reliability Process Need will result from a Generator becoming Retired, entering into a Mothball Outage, or being unavailable due to an Installed Capacity Ineligible Forced Outage, or from other changes to the availability of Resources or to the New York State Transmission System. See NYISO OATT Attachment FF

Short-Term Reliability Process: The process by which the NYISO evaluates and addresses the reliability impacts resulting from both: (i) Generator Deactivation Reliability Need(s), and/or (ii) other Reliability Needs on or affecting the Bulk Power Transmission Facilities that are identified in a Short-Term Assessment of Reliability. The Short-Term Reliability Process evaluates reliability needs in years one through five of the ten-year Study Period, with a focus on needs in years one through three. See NYISO OATT Attachment FF

Short-Term Reliability Process Need: A Generator Deactivation Reliability Need or a condition identified by the NYISO in a Short-Term Assessment of Reliability as a violation or potential violation of one or more Reliability Criteria on the Bulk Power Transmission Facilities. See NYISO OATT Attachment FF

Short-Term Reliability Process Solution: A solution to address a Short-Term Reliability Process Need, which may include (i) an Initiating Generator, (ii) a solution proposed pursuant to the NYISO Services Tariff, or (iii) a Generator identified by the NYISO pursuant to the NYISO Services Tariff. See NYISO OATT and Services Tariff

Short-Term Assessment of Reliability (STAR) Start Date: The date on which the NYISO next commences a STAR after issuing a written notice to a Market Participant indicating that the Generator Deactivation Notice for its Generator is complete. See NYISO OATT Attachment FF

Special Case Resource (“SCR”): Demand Side Resources the Load of which is capable of being interrupted upon demand at the direction of the NYISO, and/or Demand Side Resources that have a Local Generator, which is not visible to the NYISO’s Market Information System and is rated 100 kW or higher, that can be operated to reduce Load from the New York State Transmission System or the distribution system at the direction of the NYISO. See NYISO Services Tariff

System & Resource Outlook (formerly “CARIS”): Biennial report produced by the NYISO, through which it summarizes the current assessments, evaluations, and plans in the biennial Comprehensive System Planning Process, produces a twenty-year projection of congestion on the New York State Transmission System, identifies, ranks, and groups congested elements, and assesses the potential benefits of addressing the identified congestion.

System Benefits Charge (SBC): An amount of money, charged to ratepayers on their electric bills, which is administered and allocated by the New York State Energy Research and Development Authority towards energy-efficiency programs, research and development initiatives, low-income energy programs, and environmental disclosure activities.

Transfer Capability: The measure of the ability of interconnected electrical systems to reliably move or transfer power from one area to another over all transmission facilities (or paths) between those areas under specified system conditions.

Transmission Constraints: Limitations on the ability of a transmission system to transfer electricity during normal or emergency system conditions.

Transmission Owner (TO): A public utility or authority that owns transmission facilities and provides Transmission Service under the NYISO Tariffs.

Unforced Capacity: The measure by which Installed Capacity Suppliers will be rated to quantify the extent of their contribution to satisfy the New York Control Area Installed Capacity Requirement. See NYISO Services Tariff

Unforced Capacity Deliverability Rights (UDRs): Rights, as measured in MWs, associated with (i) new incremental controllable transmission projects, and (ii) new projects to increase the capability of existing controllable transmission projects that have UDRs, that provide a transmission interface to a Locality, which, under certain conditions, allow such Unforced Capacity to be treated as if it were located in the Locality, thereby contributing to an LSE’s Locational Minimum Installed Capacity Requirement. When combined with Unforced Capacity which is located in an External Control Area or non-constrained NYCA region either by contract or ownership, and which is deliverable to the NYCA interface in the Locality in which the UDR transmission facility is electrically located, UDRs allow such Unforced Capacity to be treated as if it were located in the Locality, thereby contributing to an LSE’s Locational Minimum Installed Capacity Requirement. To the extent the NYCA interface is with an External Control Area the Unforced Capacity associated with UDRs must be deliverable to the Interconnection Point. See NYISO Services Tariff

Weather Normalized: Adjustments made to normalize the impact of weather when making energy and peak demand forecasts. Using historical weather data, energy analysts can account for the influence of extreme weather conditions and adjust actual energy use and peak demand to estimate what would have happened if the hottest day or the coldest day had been the typical, or “normal,” weather conditions. “Normal” is usually calculated by taking the average of the previous 20 years of weather data.

Zone: One of the eleven regions in the New York Control Area connected to each other by identified transmission interfaces and designated as Load Zones A-K.

Appendix B - Planned Projects and Assumptions

The CRP conclusions are based on certain base case assumptions, which are summarized below.

Figure 26: Load and Capacity Data

| Year | | 2021 | 2022 | 2023 | 2024 | 2025 | 2026 | 2027 | 2028 | 2029 | 2030 |
|--------------------------------------|-----------------------------|--------|--------|--------|--------|--------|--------|--------|--------|--------|--------|
| NYCA Baseline Demand Forecast | | | | | | | | | | | |
| | NYCA* | 32,145 | 32,112 | 31,867 | 31,629 | 31,471 | 31,366 | 31,357 | 31,409 | 31,506 | 31,609 |
| | Zone J* | 11,211 | 11,378 | 11,342 | 11,292 | 11,270 | 11,271 | 11,326 | 11,399 | 11,484 | 11,573 |
| | Zone K* | 5,240 | 5,134 | 5,027 | 4,918 | 4,827 | 4,749 | 4,701 | 4,685 | 4,689 | 4,692 |
| | Zone G-J* | 15,364 | 15,518 | 15,447 | 15,368 | 15,329 | 15,322 | 15,377 | 15,454 | 15,550 | 15,652 |
| Resources (MW) | | | | | | | | | | | |
| NYCA | Capacity** | 37,334 | 37,902 | 37,155 | 37,155 | 36,551 | 36,551 | 36,551 | 36,551 | 36,551 | 36,551 |
| | Net Purchases & Sales | 1,812 | 1,816 | 1,794 | 1,954 | 1,954 | 1,954 | 1,954 | 1,954 | 1,954 | 1,954 |
| | SCR | 1,282 | 1,282 | 1,282 | 1,282 | 1,282 | 1,282 | 1,282 | 1,282 | 1,282 | 1,282 |
| | Total Resources | 40,429 | 41,001 | 40,231 | 40,391 | 39,787 | 39,787 | 39,787 | 39,787 | 39,787 | 39,787 |
| | Cap+NetPurch+SCR/Load Ratio | 125.8% | 127.7% | 126.2% | 127.7% | 126.4% | 126.8% | 126.9% | 126.7% | 126.3% | 125.9% |
| Zone J | Capacity** | 9,568 | 9,568 | 8,795 | 8,795 | 8,190 | 8,190 | 8,190 | 8,190 | 8,190 | 8,190 |
| | Full UDR Rights | 315 | 315 | 315 | 315 | 315 | 315 | 315 | 315 | 315 | 315 |
| | SCR | 479 | 479 | 479 | 479 | 479 | 479 | 479 | 479 | 479 | 479 |
| | Total Resources | 10,362 | 10,362 | 9,589 | 9,589 | 8,984 | 8,984 | 8,984 | 8,984 | 8,984 | 8,984 |
| | Cap+fullUDR+SCR/Load Ratio | 92.4% | 91.1% | 84.5% | 84.9% | 79.7% | 79.7% | 79.3% | 78.8% | 78.2% | 77.6% |
| Zone K | Capacity** | 5,226 | 5,249 | 5,213 | 5,213 | 5,213 | 5,213 | 5,213 | 5,213 | 5,213 | 5,213 |
| | Full UDR Rights | 990 | 990 | 990 | 990 | 990 | 990 | 990 | 990 | 990 | 990 |
| | SCR | 48 | 48 | 48 | 48 | 48 | 48 | 48 | 48 | 48 | 48 |
| | Total Resources | 6,264 | 6,287 | 6,251 | 6,251 | 6,251 | 6,251 | 6,251 | 6,251 | 6,251 | 6,251 |
| | Cap+fullUDR+SCR/Load Ratio | 119.5% | 122.5% | 124.3% | 127.1% | 129.5% | 131.6% | 133.0% | 133.4% | 133.3% | 133.2% |
| Zone G-J | Capacity** | 14,320 | 14,320 | 13,509 | 13,509 | 12,904 | 12,904 | 12,904 | 12,904 | 12,904 | 12,904 |
| | Full UDR Rights | 315 | 315 | 315 | 315 | 315 | 315 | 315 | 315 | 315 | 315 |
| | SCR | 605 | 605 | 605 | 605 | 605 | 605 | 605 | 605 | 605 | 605 |
| | Total Resources | 15,240 | 15,240 | 14,429 | 14,429 | 13,824 | 13,824 | 13,824 | 13,824 | 13,824 | 13,824 |
| | Cap+fullUDR+SCR/Load Ratio | 99.2% | 98.2% | 93.4% | 93.9% | 90.2% | 90.2% | 89.9% | 89.5% | 88.9% | 88.3% |

Notes:

- *NYCA load values represent baseline coincident summer peak demand. Zones J and K load values represent non-coincident summer peak demand. Aggregate Zones G-J values represent the G-J peak (Table I-5).
- **NYCA Capacity values include resources electrically internal to NYCA, additions, re-ratings, and retirements (including proposed retirements and mothballs). Capacity values reflect the lesser of CRIS and DMNC values. NYCA resources include the net purchases and sales as per the Gold Book. Zonal totals include the full UDRs Rights for those capacity zones.

- SCRs represent the forecasted MW ICAP value from 2020 [Gold Book](#);
- Wind, solar, run-of-river and landfill gas are counted as 100% of nameplate rating.
- The following graphs show the load and total capacity information from the table above.

Figure 27: Load and Capacity Year-by-Year MW

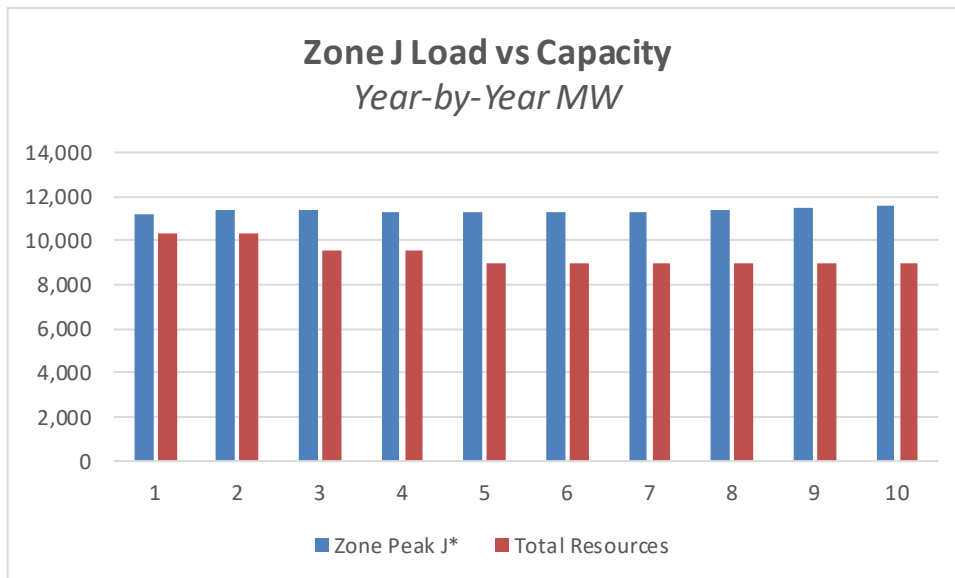
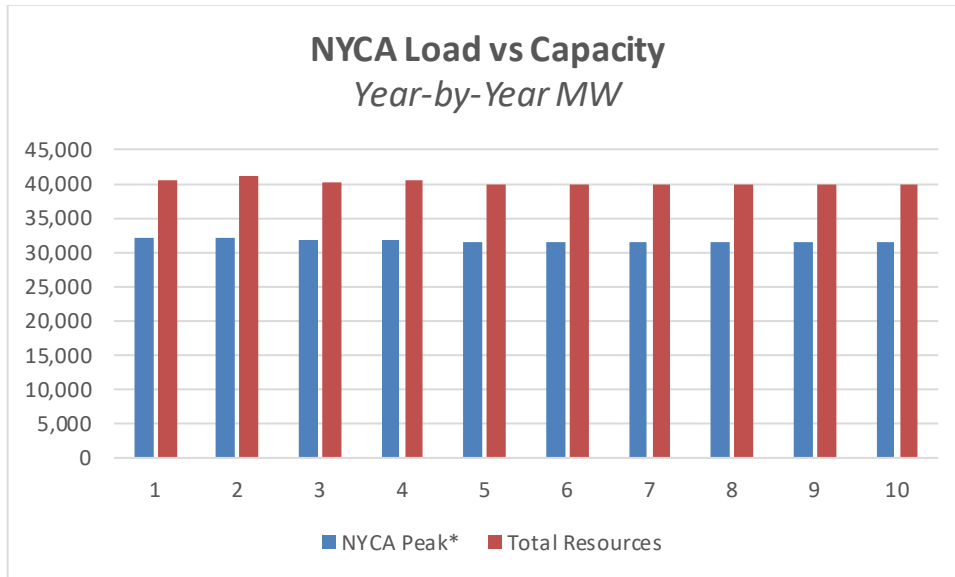

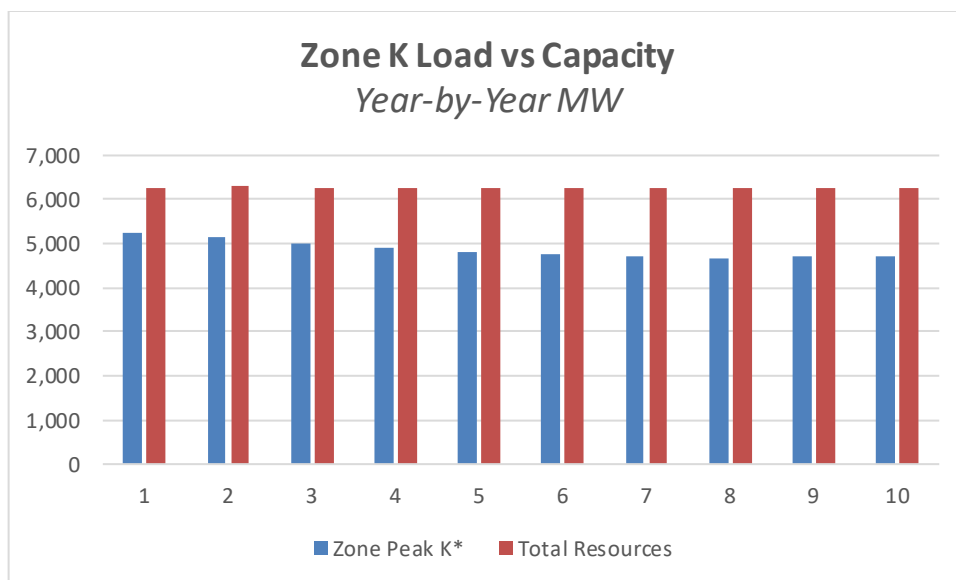

Figure 28: Baseline Peak Demand and Energy Forecasts

Baseline and Adjusted Baseline Energy Updated Forecasts

| Annual GWh | 2020 | 2021 | 2022 | 2023 | 2024 | 2025 | 2026 | 2027 | 2028 | 2029 | 2030 |
|--|---------|---------|---------|---------|---------|---------|---------|---------|---------|---------|---------|
| 2020 End-Use Energy Forecast - Nov. update | 154,860 | 157,664 | 159,328 | 160,833 | 162,153 | 163,545 | 164,704 | 165,717 | 166,535 | 167,116 | 167,475 |
| -- Energy Efficiency and Codes & Standards | 1,885 | 3,959 | 6,200 | 8,599 | 11,081 | 13,582 | 15,937 | 18,057 | 19,921 | 21,563 | 23,016 |
| -- B&T Solar PV | 2,631 | 3,274 | 3,899 | 4,563 | 5,193 | 5,738 | 6,205 | 6,591 | 6,893 | 7,130 | 7,289 |
| -- B&T Non-Solar Distributed Generation | 1,252 | 1,416 | 1,059 | 940 | 818 | 852 | 877 | 900 | 931 | 956 | 973 |
| + Storage Net Energy Consumption | 19 | 43 | 67 | 99 | 130 | 160 | 189 | 221 | 254 | 281 | 309 |
| + Electric Vehicle Energy | 199 | 345 | 538 | 781 | 1,085 | 1,456 | 1,889 | 2,407 | 3,031 | 3,765 | 4,506 |
| + Non-EV Electrification | 190 | 457 | 815 | 1,289 | 1,884 | 2,591 | 3,337 | 4,163 | 5,055 | 5,997 | 6,988 |
| November 2020 Baseline Forecast Update | 149,500 | 149,860 | 149,590 | 148,900 | 148,160 | 147,580 | 147,100 | 146,960 | 147,130 | 147,510 | 148,000 |
| + B&T Solar PV | 2,631 | 3,274 | 3,899 | 4,563 | 5,193 | 5,738 | 6,205 | 6,591 | 6,893 | 7,130 | 7,289 |
| 2020 RNA Base Case Updated Forecast¹ | 152,131 | 153,134 | 153,489 | 153,463 | 153,353 | 153,318 | 153,305 | 153,551 | 154,023 | 154,640 | 155,289 |

Baseline and Adjusted Baseline Summer Updated Peak Forecasts

| Annual MW | 2020 | 2021 | 2022 | 2023 | 2024 | 2025 | 2026 | 2027 | 2028 | 2029 | 2030 |
|---|--------|--------|--------|--------|--------|--------|--------|--------|--------|--------|--------|
| 2020 End-Use Peak Demand Forecast - Nov. update | 33,319 | 33,615 | 33,962 | 34,169 | 34,346 | 34,621 | 34,904 | 35,208 | 35,501 | 35,749 | 35,941 |
| -- Energy Efficiency and Codes & Standards | 296 | 591 | 943 | 1,322 | 1,709 | 2,108 | 2,488 | 2,825 | 3,116 | 3,360 | 3,579 |
| -- B:ITM Solar PV | 555 | 707 | 841 | 986 | 1,102 | 1,204 | 1,287 | 1,351 | 1,392 | 1,411 | 1,411 |
| -- B:ITM Non-Solar Distributed Generation | 218 | 251 | 189 | 169 | 148 | 154 | 158 | 164 | 170 | 174 | 177 |
| -- B:ITM Storage Peak Reductions | 5 | 14 | 26 | 44 | 63 | 91 | 125 | 159 | 206 | 250 | 292 |
| + Electric Vehicle Peak Demand | 40 | 68 | 103 | 147 | 201 | 261 | 333 | 418 | 513 | 625 | 748 |
| + Non-EV Electrification | 11 | 25 | 46 | 72 | 104 | 146 | 187 | 230 | 279 | 327 | 379 |
| November 2020 Baseline Forecast² Update | 32,296 | 32,145 | 32,112 | 31,867 | 31,629 | 31,471 | 31,366 | 31,357 | 31,409 | 31,506 | 31,609 |
| + B:ITM Solar PV | 555 | 707 | 841 | 986 | 1,102 | 1,204 | 1,287 | 1,351 | 1,392 | 1,411 | 1,411 |
| 2020 RNA Base Case Updated Forecast⁴ | 32,851 | 32,852 | 32,953 | 32,853 | 32,731 | 32,675 | 32,653 | 32,708 | 32,801 | 32,917 | 33,020 |

Notes:

1. For the resource adequacy study, the Gold Book baseline load forecast was modified by removing the behind-the-meter solar PV impacts in order to model the solar PV explicitly as a generation resource to account for the intermittent nature of its availability.
2. The transmission security power flow RNA base cases use this Gold Book baseline forecast.

Figure 29: Planned Additions

| Queue # | Project Name | Zone | Point of Interconnection | Summer Peak (MW) | 2020 RNA/CRP Commercial Operation Date |
|---|--|------|-----------------------------------|------------------|--|
| Proposed Transmission Additions, other than Local Transmission Owner Plans | | | | | |
| N/A* | Leeds-Hurley SDU | F,G | Leeds- Hurley SDU 345kV | n/a | summer 2021 |
| 430 | Cedar Rapids Transmission Upgrade | D | Dennison - Alcoa 115kV | 80 | 10/2021 |
| Q545A* | Empire State Line | A | Dysinger - Stolle 345kV | n/a | 6/2022 |
| 556 | Segment A Double Circuit | E,F | Edic - New Scotland 345kV | n/a | 12/2023 |
| 543 | Segment B Knickerbocker-Pleasant Valley 345 kV | F,G | Greenbush - Pleasant Valley 345kV | n/a | 12/2023 |
| Proposed Generations Additions | | | | | |
| 387* | Cassadaga Wind | A | Dunkirk - Moon Station 115 kV | 126.5 | 12/2021 |
| 396 | Baron Winds | C | Hillside - Meyer 230kV | 238.4 | 12/2021 |
| 422 | Eight Point Wind Energy Center | B | Bennett 115kV | 101.8 | 12/2021 |
| 505 | Ball Hill Wind | A | Dunkirk - Gardenville 230kV | 100.0 | 12/2022 |
| 546 | Roaring Brook Wind | E | Chases Lake Substation 230kV | 79.7 | 12/2021 |
| 678 | Calverton Solar Energy Center | K | Edwards Substation 138kV | 22.9 | 12/2021 |
| *also included in the 2019-2028 CRP Base Cases | | | Total MW generation | 669 | |

Figure 30: Assumed Deactivations

| 2020 Gold Book Table | Owner/ Operator | Plant Name | Zone | CRIS | Assumed Date |
|--|-------------------------------------|---------------------------|-------|------------|--------------|
| Table IV-3: Deactivated Units with Unexpired CRIS Rights Not Listed in Existing Capacity Table III-2 | International Paper Company | Ticonderoga (ICAP as SCR) | F | 7.6 | 05/01/2017 |
| | Helix Ravenswood, LLC | Ravenswood 09 | J | 21.7 | 11/01/2017 |
| | Binghamton BOP, LLC | Binghamton | C | 43.8 | 01/09/2018 |
| | Helix Ravenswood, LLC | Ravenswood 2-1 | J | 40.4 | 04/01/2018 |
| | | Ravenswood 2-2 | J | 37.6 | 04/01/2018 |
| | | Ravenswood 2-3 | J | 39.2 | 04/01/2018 |
| | | Ravenswood 2-4 | J | 39.8 | 04/01/2018 |
| | | Ravenswood 3-1 | J | 40.5 | 04/01/2018 |
| | | Ravenswood 3-2 | J | 38.1 | 04/01/2018 |
| | Ravenswood 3-4 | J | 35.8 | 04/01/2018 | |
| Cayuga Operating Company, LLC | Cayuga 2 | C | 154.7 | 07/01/2018 | |
| Lyonsdale Biomass, LLC | Lyonsdale | E | 20.2 | 07/18/2019 | |
| Table IV-4: Deactivated Units Listed in Existing Capacity Table III-2 | Exelon Generation Company LLC | Monroe Livingston | B | 2.4 | 09/01/2019 |
| | Innovative Energy Systems, Inc. | Steuben County LF | C | 3.2 | 09/01/2019 |
| | Consolidated Edison Co. of NY, Inc | Hudson Ave 4 | J | 13.9 | 09/10/2019 |
| | New York State Elec. & Gas Corp. | Auburn - State St | C | 5.8 | 10/01/2019 |
| | Cayuga Operating Company, LLC | Cayuga 1 | C | 154.1 | 11/01/2019 |
| | Consolidated Edison Co. of NY, Inc | Hudson Ave 3 | J | 16.0 | 11/01/2019 |
| Table IV-5: Notices of Proposed Deactivations as of March 15, 2020 | Albany Energy, LLC | Albany LFGE | F | 4.5 | 09/18/2019 |
| | Somerset Operating Company, LLC | Somerset | A | 686.5 | 02/15/2020 |
| | National Grid | West Babylon 4 | K | 49.0 | 12/11/2020 |
| | Energy Nuclear Power Marketing, LLC | Indian Point 2 | H | 1,026.5 | 04/30/2020 |
| | | Indian Point 3 | | 1,040.4 | 04/30/2021 |

Figure 31: Assumed Generation Status Change due to the DEC's Peaker Rule

| 2020 Gold Book Table | Owner/ Operator | Plant Name | Zone | CRIS | Assumed Date |
|--|-------------------------------------|-------------------------------|-------|------------|--------------|
| Table IV-6: Proposed Staus Change to Comply with DEC Peaker Rule** | Central Hudson Gas & Elec. Corp. | Coxsackie GT | G | 19.9 | 05/01/2023 |
| | | South Cairo | G | 19.8 | 05/01/2023 |
| | Consolidated Edison Co. of NY, Inc. | 74 St. GT 1 & 2 | J | 39.1 | 05/01/2023 |
| | | Hudson Ave 5 | | 15.1 | 05/01/2023 |
| | | 59 St. GT 1 | | 15.4 | 05/01/2025 |
| | Helix Ravenswood, LLC | Ravenswood 01 | J | 8.8 | 05/01/2023 |
| | | Ravenswood 10 | | 21.2 | 05/01/2023 |
| | | Ravenswood 11 | | 20.2 | 05/01/2023 |
| | National Grid | Glenwood GT 1 | K | 14.6 | 05/01/2023 |
| | | Northport GT | | 13.8 | 05/01/2023 |
| | | Port Jefferson GT 01 | | 14.1 | 05/01/2023 |
| | NRG Power Marketing, LLC | Astoria GT 2-1, 2-2, 2-3, 2-4 | J | 165.8 | 05/01/2023 |
| | | Astoria GT 3-1, 3-2, 3-3, 3-4 | | 170.7 | 05/01/2023 |
| | | Astoria GT 4-1, 4-2, 4-3, 4-4 | | 167.9 | 05/01/2023 |
| | | Arthur Kill GT1 | | 16.5 | 05/01/2025 |
| | Astoria Generating Company, L.P. | Gowanus 1-1 through 1-8 | J | 138.7 | 05/01/2023 |
| | | Gowanus 4-1 through 4-8 | | 140.1 | 05/01/2023 |
| | | Astoria GT 01 | | 15.7 | 05/01/2025 |
| | | Gowanus 2-1 through 2-8 | | 152.8 | 05/01/2025 |
| | | Gowanus 3-1 through 3-8 | | 146.8 | 05/01/2025 |
| Narrows 1-1 through 2-8 | | | 309.1 | 05/01/2025 | |
| Total** | | | | 1,626 | |

*Consistent with deactivation dates

** Some of the units will be out of service in the ozone season only

| 2020 Gold Book Table | Owner/ Operator | Plant Name | Zone | CRIS | Assumed Date |
|--|-------------------------------------|-------------------------------|-------|------------|--------------|
| Table IV-6: Proposed Staus Change to Comply with DEC Peaker Rule** | Central Hudson Gas & Elec. Corp. | Coxsackie GT | G | 19.9 | 05/01/2023 |
| | | South Cairo | G | 19.8 | 05/01/2023 |
| | Consolidated Edison Co. of NY, Inc. | 74 St. GT 1 & 2 | J | 39.1 | 05/01/2023 |
| | | Hudson Ave 5 | | 15.1 | 05/01/2023 |
| | | 59 St. GT 1 | | 15.4 | 05/01/2025 |
| | Helix Ravenswood, LLC | Ravenswood 01 | J | 8.8 | 05/01/2023 |
| | | Ravenswood 10 | | 21.2 | 05/01/2023 |
| | | Ravenswood 11 | | 20.2 | 05/01/2023 |
| | National Grid | Glenwood GT 1 | K | 14.6 | 05/01/2023 |
| | | Northport GT | | 13.8 | 05/01/2023 |
| | | Port Jefferson GT 01 | | 14.1 | 05/01/2023 |
| | NRG Power Marketing, LLC | Astoria GT 2-1, 2-2, 2-3, 2-4 | J | 165.8 | 05/01/2023 |
| | | Astoria GT 3-1, 3-2, 3-3, 3-4 | | 170.7 | 05/01/2023 |
| | | Astoria GT 4-1, 4-2, 4-3, 4-4 | | 167.9 | 05/01/2023 |
| | | Arthur Kill GT1 | | 16.5 | 05/01/2025 |
| | Astoria Generating Company, L.P. | Gowanus 1-1 through 1-8** | J | 138.7 | 05/01/2023 |
| | | Gowanus 4-1 through 4-8** | | 140.1 | 05/01/2023 |
| | | Astoria GT 01** | | 15.7 | 05/01/2025 |
| | | Gowanus 2-1 through 2-8** | | 152.8 | 05/01/2025 |
| | | Gowanus 3-1 through 3-8** | | 146.8 | 05/01/2025 |
| Narrows 1-1 through 2-8** | | | 309.1 | 05/01/2025 | |
| Total** | | | | 1,626 | |

*Consistent with deactivation dates

** Some of the units will be out of service in the ozone season only

In addition to the projects that met the 2020-2021 RPP inclusion rules, a number of other projects are

progressing through the ~~NYISO's interconnection process.~~NYISO's interconnection process. Some of these additional generation resources either have accepted their cost allocation as part of a prior Class Year Facilities Study process, or are included in the Class Year 2021 Facilities Study, or are candidates for future interconnection facilities studies. The most recent list of these projects resides in the 2021 Gold Book.

Figure 32: Firm Transmission Plans included in 2020 RNA Base Case

| Transmission Owner | Terminals | | Line Length in Miles | In-Service | | Nominal Voltage | | # of ckt | Thermal Ratings (4) | | Project Description / Conductor Size |
|--|------------------|------------------|----------------------|--------------|------|-----------------|---------|----------|---------------------|---------|--|
| | | | | Date/Yr | | in kV | | | Summer | Winter | |
| | | | | Prior to (2) | Year | Operating | Design | | | | |
| Firm Plans (5) (included in FERC 715 Base Case) | | | | | | | | | | | |
| ConEd | Jamaica | Jamaica | Reconfiguration | In-Service | 2019 | 138 | 138 | | N/A | N/A | Reconfiguration |
| ConEd | East 13th Street | East 13th Street | xfmr | In-Service | 2019 | 345 | 345 | | N/A | N/A | Replacing xfmr 10 and xfmr 11 |
| ConEd | Gowanus | Gowanus | xfmr | In-Service | 2019 | 345 | 345 | | N/A | N/A | Replacing xfmr T2 |
| ConEd | East 13th Street | East 13th Street | Reconfiguration | In-Service | 2019 | 345 | 345 | | N/A | N/A | Reconfiguration (xfmr 10 -xfmr 11) |
| ConEd | Rainey | Corona | xfmr/Phase shifter | In-Service | 2019 | 345/138 | 345/138 | 1 | 268 MVA | 320 MVA | xfmr/Phase shifter |
| LIPA | Far Rockaway | Far Rockaway | Reconfiguration | In-Service | 2019 | 34.5 | 34.5 | | N/A | N/A | Reconfigure 34.5 kV switchgear |
| LIPA | Elwood | Elwood | Breaker | In-Service | 2019 | 138 | 138 | | N/A | N/A | Install double bus tie - Operate Normally Open |
| LIPA | Canal | Southampton | 5.20 | In-Service | 2019 | 69 | 69 | 1 | 1107 | 1169 | 2500 kcmil XLPE CU |
| LIPA | Deer Park | Deer Park | - | W | 2019 | 69 | 69 | 1 | N/A | N/A | Install 27 MVAR Cap Bank |
| LIPA | MacArthur | MacArthur | - | W | 2019 | 69 | 69 | 1 | N/A | N/A | Install 27 MVAR Cap Bank |
| LIPA | West Hempstead | East Garden City | -2.92 | In-Service | 2019 | 69 | 69 | 1 | 1158 | 1245 | 477 ACSS |
| LIPA | West Hempstead | Hempstead | 0.97 | In-Service | 2019 | 69 | 69 | 1 | 1158 | 1245 | 477 ACSS |
| LIPA | Hempstead | East Garden City | 1.95 | In-Service | 2019 | 69 | 69 | 1 | 1158 | 1245 | 477 ACSS |
| LIPA | Pilgrim | West Bus | -11.86 | In-Service | 2019 | 138 | 138 | 1 | 2087 | 2565 | 2493 ACAR |
| LIPA | West Bus | Kings | 8.25 | In-Service | 2019 | 138 | 138 | 1 | 2087 | 2565 | 2493 ACAR |
| LIPA | Pilgrim | Kings | 4.81 | In-Service | 2019 | 138 | 138 | 1 | 2087 | 2565 | 2493 ACAR |
| NGRID | Golah | Golah | Cap Bank | In-Service | 2019 | 115 | 115 | 1 | 18MVAR | 18MVAR | Capacitor Bank |
| NGRID | Falls Park | Schodack(NG) | 17.33 | In-Service | 2019 | 115 | 115 | 1 | 186 MVA | 227 MVA | Loop for NYSEG Sub Will Reconfigure NG Line #14 Into Two New Lines |
| NGRID | Falls Park | Churchtown | 9.41 | In-Service | 2019 | 115 | 115 | 1 | 175 MVA | 206 MVA | Loop for NYSEG Sub Will Reconfigure NG Line #14 Into Two New Lines |

| Transmission Owner | Terminals | | Line Length in Miles | In-Service | | Nominal Voltage | | # of ckts | Thermal Ratings (4) | | Project Description / Conductor Size |
|--------------------|----------------------------|----------------------------|----------------------|--------------|------|-----------------|----------|-----------|---------------------|---------|--|
| | | | | Date/Yr | | in kV | | | Summer | Winter | |
| | | | | Prior to (2) | Year | Operating | Design | | | | |
| NGRID | Batavia | Batavia | Cap Bank | In-Service | 2019 | 115 | 115 | 1 | 30MVAR | 30MVAR | Second Capacitor Bank |
| NGRID | Battenkill | Eastover Road | -22.72 | In-Service | 2019 | 115 | 115 | 1 | 937 | 1141 | New Schaghticoke Switching Station |
| NGRID | Battenkill | Schaghticoke (New Station) | 14.31 | In-Service | 2019 | 115 | 115 | 1 | 937 | 1141 | New Schaghticoke Switching Station |
| NGRID | Schaghticoke (New Station) | Eastover Road | 8.41 | In-Service | 2019 | 115 | 115 | 1 | 937 | 1141 | New Schaghticoke Switching Station |
| NGRID | Mohican | Luther Forest | -34.47 | In-Service | 2019 | 115 | 115 | 1 | 937 | 1141 | New Schaghticoke Switching Station |
| NGRID | Mohican | Schaghticoke (New Station) | 28.13 | In-Service | 2019 | 115 | 115 | 1 | 937 | 1141 | New Schaghticoke Switching Station |
| NGRID | Ohio St | Ohio St | | In-Service | 2019 | 115 | 115 | | N/A | N/A | New Distribution Station at Ohio Street |
| NGRID | Albany Steam | Greenbush | 6.14 | In-Service | 2019 | 115 | 115 | 2 | 1190 | 1527 | Reconductor Albany - Greenbush 115kV lines 1 & 2 |
| NGRID | Schodack | Churchtown | -26.74 | In-Service | 2019 | 115 | 115 | 1 | 937 | 1141 | Line removal tapped by Falls Park Project |
| NGRID | Sodeman Rd | Sodeman Rd | | In-Service | 2019 | 115 | 115 | | N/A | N/A | New Distribution Station at Sodeman Road |
| NGRID | Dewitt | Dewitt | | In-Service | 2019 | 115 | 115 | | N/A | N/A | New Distribution Station at Dewitt |
| NGRID | Luther Forest | Schaghticoke (New Station) | 6.34 | In-Service | 2019 | 115 | 115 | 1 | 1280 | 1563 | New Schaghticoke Switching Station |
| NGRID | Seneca | Seneca | - | In-Service | 2019 | 115/22 | 115/22 | - | 50MVA | 50MVA | Damage/Failure on TR2 |
| NGRID | Mortimer | Mortimer | Reconfiguration | In-Service | 2019 | 115 | 115 | 1 | N/A | N/A | Reconfiguration of Station |
| NGRID | Mohican | Butler | 3.50 | S | 2019 | 115 | 115 | 1 | TBD | TBD | Replace 3.5 miles of conductor w/min 336.4 ACSR |
| NYSEG | Wood Street | Carmel | 1.34 | In-Service | 2019 | 115 | 115 | 1 | 261 MVA | 261 MVA | 477 ACSR |
| NYSEG | Flat Street | Flat Street | xfmr | In-Service | 2019 | 115/34.5 | 115/34.5 | 2 | 40MVA | 45.2MVA | Transformer #2 |
| NYSEG | Falls Park 115/34.5kV | | | In-Service | 2019 | 115/34.5 | 115/34.5 | | | | Tap to interconnect NG Line #14 |
| NYSEG | Falls Park | Falls Park | xfmr | In-Service | 2019 | 115/34.5 | 115/34.5 | 1 | 62 MVA | 70 MVA | Transformer #1 |

| Transmission Owner | Terminals | | Line Length in Miles | In-Service | | Nominal Voltage | | # of ckts | Thermal Ratings (4) | | Project Description / Conductor Size |
|--------------------|------------------|-------------------------|----------------------|--------------|------|-----------------|---------------|-----------|---------------------|---------|---|
| | | | | Date/Yr | | in kV | | | Summer | Winter | |
| | | | | Prior to (2) | Year | Operating | Design | | | | |
| RGE | Station 42 | Station 23 | Phase Shifter | In-Service | 2019 | 115 | 115 | 1 | 253 MVA | 253 MVA | Phase Shifter |
| RGE | Station 23 | Station 23 | xfmr | In-Service | 2019 | 115/11.5/11.5 | 115/11.5/11.5 | 2 | 75 MVA | 84 MVA | Transformer |
| RGE | Station 23 | Station 23 | xfmr | W | 2019 | 115/34.5 | 115/34.5 | 2 | 75 MVA | 84 MVA | Transformer |
| CHGE | North Chelsea | North Chelsea | xfmr | S | 2020 | 115/69 | 115/69 | 1 | 564 | 728 | Replace Transformer 1 |
| CHGE | Fishkill Plains | East Fishkill | 2.05 | S | 2020 | 115 | 115 | 1 | 995 | 1218 | 1-1033.5 ACSR |
| CHGE | North Catskill | North Catskill | xfmr | W | 2020 | 115/69 | 115/69 | 2 | 560 | 726 | Replace Transformer 4 & 5 |
| ConEd | Buchanan North | Buchanan North | Reconfiguration | S | 2020 | 345 | 345 | | N/A | N/A | Reconfiguration (bus work related to decommissioning of Indain Point 2) |
| LIPA | Meadowbrook | East Garden City | -3.11 | S | 2020 | 69 | 69 | 1 | 458 | 601 | 4/0 CU |
| LIPA | East Garden City | Lindbergh | 2.50 | S | 2020 | 69 | 69 | 1 | 575 | 601 | 750 kcmil CU |
| LIPA | Lindbergh | Meadowbrook | 2.11 | S | 2020 | 69 | 69 | 1 | 458 | 601 | 4/0 CU |
| LIPA | Elmont | Floral Park | -1.59 | S | 2020 | 34.5 | 34.5 | 1 | 644 | 816 | 477 AL |
| LIPA | Elmont | Belmont | 1.82 | S | 2020 | 34.5 | 34.5 | 1 | 342 | 457 | 2/0 CU |
| LIPA | Belmont | Floral Park | 2.04 | S | 2020 | 34.5 | 34.5 | 1 | 644 | 816 | 477 AL |
| LIPA | MacArthur | - | Cap Bank | S | 2020 | 69 | 69 | 1 | 27MVAR | 27 MVAR | Capacitor bank |
| NGRID | Rosa Rd | Rosa Rd | - | S | 2020 | 115 | 115 | | N/A | N/A | Install 35.2MVAR Cap Bank at Rosa Rd |
| NGRID | Rotterdam | Curry Rd | 7 | S | 2020 | 115 | 115 | 1 | 808 | 856 | Replace 7.0 miles of mainly 4/0 Cu conductor with 795kcmil ACSR 26/7 |
| NGRID | Elm St | Elm St | xfmr | S | 2020 | 230/23 | 230/23 | 1 | 118MVA | 133MVA | Add a fourth 230/23kV transformer |
| NGRID | West Ashville | West Ashville | | S | 2020 | 115 | 115 | | N/A | N/A | New Distribution Station at West Ashville |
| NGRID | Spier | Rotterdam (#2) | -32.74 | S | 2020 | 115 | 115 | 1 | 1168 | 1416 | New Lasher Rd Switching Station |
| NGRID | Spier | Lasher Rd (New Station) | 21.69 | S | 2020 | 115 | 115 | 1 | 1168 | 1416 | New Lasher Rd Switching Station |

| Transmission Owner | Terminals | | Line Length in Miles | In-Service | | Nominal Voltage | | # of ckts | Thermal Ratings (4) | | Project Description / Conductor Size |
|---|------------------|------------------|----------------------|--------------|------|-----------------|---------|-----------|---------------------|---------|--|
| | | | | Date/Yr | | in kV | | | Summer | Winter | |
| | | | | Prior to (2) | Year | Operating | Design | | | | |
| 2020 Gold Book - Firm Plans (5) (included in FERC 715 Base Case) | | | | | | | | | | | |
| ConEd | Jamaica | Jamaica | Reconfiguration | In-Service | 2019 | 138 | 138 | | N/A | N/A | Reconfiguration |
| ConEd | East 13th Street | East 13th Street | xfmr | In-Service | 2019 | 345 | 345 | | N/A | N/A | Replacing xfmr 10 and xfmr 11 |
| ConEd | Gowanus | Gowanus | xfmr | In-Service | 2019 | 345 | 345 | | N/A | N/A | Replacing xfmr T2 |
| ConEd | East 13th Street | East 13th Street | Reconfiguration | In-Service | 2019 | 345 | 345 | | N/A | N/A | Reconfiguration (xfmr 10 -xfmr 11) |
| ConEd | Rainey | Corona | xfmr/Phase shifter | In-Service | 2019 | 345/138 | 345/138 | 1 | 268 MVA | 320 MVA | xfmr/Phase shifter |
| LIPA | Far Rockaway | Far Rockaway | Reconfiguration | In-Service | 2019 | 34.5 | 34.5 | | N/A | N/A | Reconfigure 34.5 kV switchgear |
| LIPA | Elwood | Elwood | Breaker | In-Service | 2019 | 138 | 138 | | N/A | N/A | Install double bus tie - Operate Normally Open |
| LIPA | Canal | Southampton | 5.20 | In-Service | 2019 | 69 | 69 | 1 | 1107 | 1169 | 2500 kcmil XLPE CU |
| LIPA | Deer Park | Deer Park | - | In-Service | 2019 | 69 | 69 | 1 | N/A | N/A | Install 27 MVAR Cap Bank |
| LIPA | MacArthur | MacArthur | - | In-Service | 2019 | 69 | 69 | 1 | N/A | N/A | Install 27 MVAR Cap Bank |
| LIPA | West Hempstead | East Garden City | -2.92 | In-Service | 2019 | 69 | 69 | 1 | 1158 | 1245 | 477 ACSS |
| LIPA | West Hempstead | Hempstead | 0.97 | In-Service | 2019 | 69 | 69 | 1 | 1158 | 1245 | 477 ACSS |
| LIPA | Hempstead | East Garden City | 1.95 | In-Service | 2019 | 69 | 69 | 1 | 1158 | 1245 | 477 ACSS |
| LIPA | Pilgrim | West Bus | -11.86 | In-Service | 2019 | 138 | 138 | 1 | 2087 | 2565 | 2493 ACAR |
| LIPA | West Bus | Kings | 8.25 | In-Service | 2019 | 138 | 138 | 1 | 2087 | 2565 | 2493 ACAR |
| LIPA | Pilgrim | Kings | 4.81 | In-Service | 2019 | 138 | 138 | 1 | 2087 | 2565 | 2493 ACAR |
| NGRID | Golah | Golah | Cap Bank | In-Service | 2019 | 115 | 115 | 1 | 18MVAR | 18MVAR | Capacitor Bank |
| NGRID | Falls Park | Schodack(NG) | 17.33 | In-Service | 2019 | 115 | 115 | 1 | 186 MVA | 227 MVA | Loop for NYSEG Sub Will Reconfigure NG Line #14 Into Two New Lines |
| NGRID | Falls Park | Churchtown | 9.41 | In-Service | 2019 | 115 | 115 | 1 | 175 MVA | 206 MVA | Loop for NYSEG Sub Will Reconfigure NG Line #14 Into Two New Lines |

| Transmission Owner | Terminals | | Line Length in Miles | In-Service | | Nominal Voltage | | # of ckts | Thermal Ratings (4) | | Project Description / Conductor Size |
|---|----------------------------------|----------------------------|----------------------|--------------|------|-----------------|----------|-----------|---------------------|---------|--|
| | | | | Date/Yr | | in kV | | | Summer | Winter | |
| | | | | Prior to (2) | Year | Operating | Design | | | | |
| 2020 Gold Book - Firm Plans (5) (included in FERC 715 Base Case) | | | | | | | | | | | |
| NGRID | Batavia | Batavia | Cap Bank | In-Service | 2019 | 115 | 115 | 1 | 30MVAR | 30MVAR | Second Capacitor Bank |
| NGRID | Battenkill | Eastover Road | -22.72 | In-Service | 2019 | 115 | 115 | 1 | 937 | 1141 | New Schaghticoke Switching Station |
| NGRID | Battenkill | Schaghticoke (New Station) | 14.31 | In-Service | 2019 | 115 | 115 | 1 | 937 | 1141 | New Schaghticoke Switching Station |
| NGRID | Schaghticoke (New Station) | Eastover Road | 8.41 | In-Service | 2019 | 115 | 115 | 1 | 937 | 1141 | New Schaghticoke Switching Station |
| NGRID | Mohican | Luther Forest | -34.47 | In-Service | 2019 | 115 | 115 | 1 | 937 | 1141 | New Schaghticoke Switching Station |
| NGRID | Mohican | Schaghticoke (New Station) | 28.13 | In-Service | 2019 | 115 | 115 | 1 | 937 | 1141 | New Schaghticoke Switching Station |
| NGRID | Ohio St | Ohio St | | In-Service | 2019 | 115 | 115 | | N/A | N/A | New Distribution Station at Ohio Street |
| NGRID | Albany Steam | Greenbush | 6.14 | In-Service | 2019 | 115 | 115 | 2 | 1190 | 1527 | Reconductor Albany - Greenbush 115kV lines 1 & 2 |
| NGRID | Schodack | Churchtown | -26.74 | In-Service | 2019 | 115 | 115 | 1 | 937 | 1141 | Line removal tapped by Falls Park Project |
| NGRID | Sodeman Rd | Sodeman Rd | | In-Service | 2019 | 115 | 115 | | N/A | N/A | New Distribution Station at Sodeman Road |
| NGRID | Dewitt | Dewitt | | In-Service | 2019 | 115 | 115 | | N/A | N/A | New Distribution Station at Dewitt |
| NGRID | Luther Forest | Schaghticoke (New Station) | 6.34 | In-Service | 2019 | 115 | 115 | 1 | 1280 | 1563 | New Schaghticoke Switching Station |
| NGRID | Seneca | Seneca | - | In-Service | 2019 | 115/22 | 115/22 | - | 50MVA | 50MVA | Damage/Failure on TR2 |
| NGRID | Mortimer | Mortimer | Reconfiguration | In-Service | 2019 | 115 | 115 | 1 | N/A | N/A | Reconfiguration of Station |
| NGRID | Mohican | Butler | 3.50 | S | 2019 | 115 | 115 | 1 | TBD | TBD | Replace 3.5 miles of conductor w/min 336.4 ACSR |
| NYSEG | Wood Street | Carmel | 1.34 | In-Service | 2019 | 115 | 115 | 1 | 261 MVA | 261 MVA | 477 ACSR |
| NYSEG | Flat Street | Flat Street | xfmr | In-Service | 2019 | 115/34.5 | 115/34.5 | 2 | 40MVA | 45.2MVA | Transformer #2 |
| NYSEG | Falls Park 115/34.5kV Substation | | | In-Service | 2019 | 115/34.5 | 115/34.5 | | | | Tap to interconnect NG Line #14 |
| NYSEG | Falls Park | Falls Park | xfmr | In-Service | 2019 | 115/34.5 | 115/34.5 | 1 | 62 MVA | 70 MVA | Transformer #1 |

| Transmission Owner | Terminals | | Line Length in Miles | In-Service | | Nominal Voltage | | # of ckts | Thermal Ratings (4) | | Project Description / Conductor Size |
|---|------------------|------------------------------|----------------------|--------------|------|-----------------|---------------|-----------|---------------------|---------|---|
| | | | | Date/Yr | | in kV | | | Summer | Winter | |
| | | | | Prior to (2) | Year | Operating | Design | | | | |
| 2020 Gold Book - Firm Plans (5) (included in FERC 715 Base Case) | | | | | | | | | | | |
| RGE | Station 42 | Station 23 | Phase Shifter | In-Service | 2019 | 115 | 115 | 1 | 253 MVA | 253 MVA | Phase Shifter |
| RGE | Station 23 | Station 23 | xfmr | In-Service | 2019 | 115/11.5/1.5 | 115/11.5/11.5 | 2 | 75 MVA | 84 MVA | Transformer |
| RGE | Station 23 | Station 23 | xfmr | W | 2019 | 115/34.5 | 115/34.5 | 2 | 75 MVA | 84 MVA | Transformer |
| CHGE | North Chelsea | North Chelsea | xfmr | S | 2020 | 115/69 | 115/69 | 1 | 564 | 728 | Replace Transformer 1 |
| CHGE | Fishkill Plains | East Fishkill | 2.05 | S | 2020 | 115 | 115 | 1 | 995 | 1218 | 1-1033.5 ACSR |
| CHGE | North Catskill | North Catskill | xfmr | W | 2020 | 115/69 | 115/69 | 2 | 560 | 726 | Replace Transformer 4 & 5 |
| ConEd | Buchanan North | Buchanan North | Reconfiguration | S | 2020 | 345 | 345 | | N/A | N/A | Reconfiguration (bus work related to decommissioning of Indain Point 2) |
| LIPA | Meadowbrook | East Garden City | -3.11 | S | 2020 | 69 | 69 | 1 | 458 | 601 | 4/0 CU |
| LIPA | East Garden City | Lindbergh | 2.50 | S | 2020 | 69 | 69 | 1 | 575 | 601 | 750 kcmil CU |
| LIPA | Lindbergh | Meadowbrook | 2.11 | S | 2020 | 69 | 69 | 1 | 458 | 601 | 4/0 CU |
| LIPA | Elmont | Floral Park | -1.59 | S | 2020 | 34.5 | 34.5 | 1 | 644 | 816 | 477 AL |
| LIPA | Elmont | Belmont | 1.82 | S | 2020 | 34.5 | 34.5 | 1 | 342 | 457 | 2/0 CU |
| LIPA | Belmont | Floral Park | 2.04 | S | 2020 | 34.5 | 34.5 | 1 | 644 | 816 | 477 AL |
| NGRID | Rosa Rd | Rosa Rd | - | S | 2020 | 115 | 115 | | N/A | N/A | Install 35.2MVAR Cap Bank at Rosa Rd |
| NGRID | Rotterdam | Curry Rd | 7 | S | 2020 | 115 | 115 | 1 | 808 | 856 | Replace 7.0 miles of mainly 4/0 Cu conductor with 795kcmil ACSR 26/7 |
| NGRID | Elm St | Elm St | xfmr | S | 2020 | 230/23 | 230/23 | 1 | 118MVA | 133MVA | Add a fourth 230/23kV transformer |
| NGRID | West Ashville | West Ashville | | S | 2020 | 115 | 115 | | N/A | N/A | New Distribution Station at West Ashville |
| NGRID | Spier | Rotterdam (#2) | -32.74 | S | 2020 | 115 | 115 | 1 | 1168 | 1416 | New Lasher Rd Switching Station |
| NGRID | Spier | Lasher Rd (New Station) (#2) | 21.69 | S | 2020 | 115 | 115 | 1 | 1168 | 1416 | New Lasher Rd Switching Station |

| Transmission Owner | Terminals | | Line Length in Miles | In-Service | | Nominal Voltage | | # of cks | Thermal Ratings (4) | | Project Description / Conductor Size |
|--------------------|---------------------------|---------------------------|----------------------|--------------|------|-----------------|---------|----------|---------------------|----------|--|
| | | | | Date/Yr | | in kV | | | Summer | Winter | |
| | | | | Prior to (2) | Year | Operating | Design | | | | |
| NGRID | Lasher Rd (New Station) | Rotterdam | 11.05 | S | 2020 | 115 | 115 | 1 | 2080 | 2392 | New Lasher Rd Switching Station |
| NGRID | Spier | Luther Forest (#302) | -34.21 | S | 2020 | 115 | 115 | 1 | 916 | 1070 | New Lasher Rd Switching Station |
| NGRID | Spier | Lasher Rd (New Station) | 21.72 | S | 2020 | 115 | 115 | 1 | 916 | 1118 | New Lasher Rd Switching Station |
| NGRID | Lasher Rd (New Station) | Luther Forest | 12.49 | S | 2020 | 115 | 115 | 1 | 990 | 1070 | New Lasher Rd Switching Station |
| NGRID | Rotterdam | Rotterdam | - | S | 2020 | 115 | 115 | 2 | N/A | N/A | Install Series Reactors at Rotterdam Station on lines 17 & 19 |
| NGRID | Huntley | Lockport | 6.9 | S | 2020 | 115 | 115 | 2 | 1303 | 1380 | Replace 6.9 miles of 36 and 37 lines |
| NGRID | Two Mile Creek | Two Mile Creek | | S | 2020 | 115 | 115 | | N/A | N/A | New Distribution Station at Two Mile Creek |
| NGRID | Maple Ave | Maple Ave | | S | 2020 | 115 | 115 | | N/A | N/A | New Distribution Station at Maple Ave |
| NGRID | Randall Rd | Randall Rd | | S | 2020 | 115 | 115 | | N/A | N/A | New Distribution Station at Randall Road |
| NGRID | GE | Geres Lock | 7.14 | S | 2020 | 115 | 115 | 1 | 785 | 955 | Reconductoring 4/OCU & 336 ACSR to 477 ACCR (Line #8) |
| NGRID | Gardenville 115kV | Gardenville 115kV | - | S | 2020 | - | - | - | - | - | Rebuild of Gardenville 115kV Station to full breaker and a half |
| NGRID | Rotterdam | Woodlawn | 7 | S | 2020 | 115 | 115 | 1 | | | Replace 7.0 miles of mainly 4/0 Cu conductor with 795kcmil ACSR 26/7 |
| NGRID | Gardenville 230kV | Gardenville 115kV | xfmr | S | 2020 | 230/115 | 230/115 | - | 347 MVA | 422 MVA | Replacement of 230/115kV TB#4 stepdown with larger unit |
| NGRID | Oswego | Oswego | - | W | 2020 | 115 | 115 | | N/A | N/A | Rebuild of Oswego 115kV Station |
| NYP&A | Fraser Annex | Fraser Annex | SSR Detection | S | 2020 | 345 | 345 | 1 | 1793 MVA | 1793 MVA | MSSC SSR Detection Project |
| NYP&A | Niagara | Rochester | -70.20 | W | 2020 | 345 | 345 | 1 | 2177 | 2662 | 2-795 ACSR |
| NYP&A | Somerset | Rochester | -44.00 | W | 2020 | 345 | 345 | 1 | 2177 | 2662 | 2-795 ACSR |
| NYP&A | Niagara | Station 255 (New Station) | 66.40 | W | 2020 | 345 | 345 | 1 | 2177 | 2662 | 2-795 ACSR |
| NYP&A | Somerset | Station 255 (New Station) | 40.20 | W | 2020 | 345 | 345 | 1 | 2177 | 2662 | 2-795 ACSR |
| NYP&A | Station 255 (New Station) | Rochester | 3.80 | W | 2020 | 345 | 345 | 2 | 2177 | 2662 | 2-795 ACSR |

| Transmission Owner | Terminals | | Line Length in Miles | In-Service Date/Yr | | Nominal Voltage in kV | | # of ckts | Thermal Ratings (4) | | Project Description / Conductor Size |
|--------------------|---------------------------|---------------------------|------------------------------|--------------------|----------------|-----------------------|----------|-----------|---------------------|--------------|--|
| | | | | Prior to (2) | Year | Operating | Design | | Summer | Winter | |
| | | | | NYPA | Niagara 230 kV | Niagara 230 kV | Breaker | | W | 2020 | |
| NYPA | Niagara 230 kV | Niagara 115 kV | Autotransformer | S | 2020 | 230 | 115 | 1 | 240 MVA | 240 MVA | Replace Niagara AT #1 |
| NYPA | Astoria 138 kV | Astoria 13.8 kV | Astoria CC GSU Refurbishment | W | 2020 | 138 | 18 | 1 | 234 | 234 | Astoria CC GSU Refurbishment |
| NYSEG | Watercure Road | Watercure Road | xfmr | W | 2020 | 345/230 | 345/230 | 1 | 426 MVA | 494 MVA | Transformer #2 and Station Reconfiguration |
| NYSEG | Willet | Willet | xfmr | W | 2020 | 115/34.5 | 115/34.5 | 1 | 39 MVA | 44 MVA | Transformer #2 |
| NYSEG | Coddington | E. Ithaca (to Coddington) | 8.07 | W | 2020 | 115 | 115 | 1 | 307 MVA | 307 MVA | 665 ACCR |
| O & R | West Nyack | West Nyack | Cap Bank | S | 2020 | 138 | 138 | 1 | - | - | Capacitor Bank |
| O & R | Harings Corner (RECO) | Closter (RECO) | 3.20 | S | 2020 | 69 | 69 | 1 | 1098 | 1312 | UG Cable |
| O & R | Ramapo | Ramapo | xfmr | S | 2020 | 345/138 | 345/138 | 1 | 731 | 731 | - |
| RGE | Station 122-Pannell-PC1 | Station 122-Pannell-PC1 | | S | 2020 | 345 | 345 | 1 | 1314 MVA-LTE | 1314 MVA-LTE | Relay Replacement |
| RGE | Station 262 | Station 23 | 1.46 | W | 2020 | 115 | 115 | 1 | 2008 | 2008 | Underground Cable |
| RGE | Station 33 | Station 262 | 2.97 | W | 2020 | 115 | 115 | 1 | 2008 | 2008 | Underground Cable |
| RGE | Station 262 | Station 262 | xfmr | W | 2020 | 115/34.5 | 115/34.5 | 1 | 58.8MVA | 58.8MVA | Transformer |
| RGE | Station 255 (New Station) | Rochester | 3.80 | W | 2020 | 345 | 345 | 1 | 2177 | 2662 | 2-795 ACSR |
| RGE | Station 255 (New Station) | Station 255 (New Station) | xfmr | W | 2020 | 345/115 | 345/115 | 1 | 400 MVA | 450 MVA | Transformer |
| RGE | Station 255 (New Station) | Station 255 (New Station) | xfmr | W | 2020 | 345/115 | 345/115 | 2 | 400 MVA | 450 MVA | Transformer |
| RGE | Station 255 (New Station) | Station 418 | 9.60 | W | 2020 | 115 | 115 | 1 | 1506 | 1807 | New 115kV Line |
| RGE | Station 255 (New Station) | Station 23 | 11.10 | W | 2020 | 115 | 115 | 1 | 1506 | 1807 | New 115kV Line |
| CHGE | Hurley Avenue | Leeds | Static synchronous | S | 2021 | 345 | 345 | 1 | 2336 | 2866 | 21% Compensation |
| LIPA | Valley Stream | East Garden City | 7.36 | S | 2021 | 138 | 138 | 1 | 1171 | 1171 | 2000 SQMM XLPE |

| Transmission Owner | Terminals | | Line Length in Miles | In-Service | | Nominal Voltage | | # of cks | Thermal Ratings (4) | | Project Description / Conductor Size |
|--------------------|--------------------|--------------------|----------------------|--------------|------|-----------------|----------|----------|---------------------|---------|--|
| | | | | Date/Yr | | in kV | | | Summer | Winter | |
| | | | | Prior to (2) | Year | Operating | Design | | | | |
| LIPA | Amagansett | Montauk | -13.00 | S | 2021 | 23 | 23 | 1 | 577 | 657 | 750 kcmil CU |
| LIPA | Amagansett | Navy Road | 12.74 | S | 2021 | 23 | 23 | 1 | 577 | 657 | 750 kcmil CU |
| LIPA | Navy Road | Montauk | 0.26 | S | 2021 | 23 | 23 | 1 | 577 | 657 | 750 kcmil CU |
| LIPA | Riverhead | Wildwood | 10.63 | S | 2021 | 138 | 138 | 1 | 1399 | 1709 | 1192ACSR |
| LIPA | Riverhead | Canal | 16.49 | S | 2021 | 138 | 138 | 1 | 1000 | 1110 | 2368 KCMIL (1200 mm ²) Copper XLPE |
| LIPA | Deer Park | - | Cap Bank | S | 2021 | 69 | 69 | 1 | 27MVAR | 27 MVAR | Capacitor bank |
| NGRID | Clay | Dewitt | 10.24 | S | 2021 | 115 | 115 | 1 | 220MVA | 268MVA | Reconductor 4/0 CU to 795ACSR |
| NGRID | Clay | Teall | 12.75 | S | 2021 | 115 | 115 | 1 | 220 MVA | 268MVA | Reconductor 4/0 CU to 795ACSR |
| NGRID | Gardenville 230kV | Gardenville 115kV | xmfr | S | 2021 | 230/115 | 230/115 | - | 347 MVA | 422 MVA | Replacement of 230/115kV TB#3 stepdown with larger unit |
| NGRID | Huntley 115kV | Huntley 115kV | - | S | 2021 | 230 | 230 | - | N/A | N/A | Rebuild of Huntley 115kV Station |
| NGRID | Mortimer | Mortimer | xmfr | S | 2021 | 115 | 115 | | 50MVA | 50MVA | Replace Mortimer 115/69kV Transformer |
| NGRID | Mortimer | Mortimer | - | S | 2021 | 115 | 115 | | N/A | N/A | Second 115kV Bus Tie Breaker at Mortimer Station |
| NGRID | New Bethlehem | New Bethlehem | - | S | 2021 | 115 | 115 | | N/A | N/A | New Bethlehem 115/13.2kV station |
| NGRID | New Cicero | New Cicero | | S | 2021 | 115 | 115 | | N/A | N/A | New Distribution Station at New Cicero |
| NGRID | Mountain | Lockport | 0.08 | S | 2021 | 115 | 115 | 2 | 174MVA | 199MVA | Mountain-Lockport 103/104 Bypass |
| NGRID | Royal Ave | Royal Ave | - | S | 2021 | 115/13.2 | 115/13.2 | - | - | - | Install new 115-13.2 kV distribution substation in Niagara Falls (Royal Ave) |
| NGRID | Niagara | Packard | 3.4 | W | 2021 | 115 | 115 | 1 | 344MVA | 449MVA | Replace 3.4 miles of 192 line |
| NYP&A | Moses 230 kV | Adirondack 230 kV | Series Compensation | S | 2021 | 230 | 230 | - | ±13.2kV | ±13.2kV | Voltage Source Series Compensation |
| NYP&A | St. Lawrence 230kV | St. Lawrence 115kV | xmfr | S | 2021 | 230/115 | 230/115 | 1 | TBD | TBD | Replacement of St. Lawrence AutoTransformer #2 |
| NYP&A | Plattsburg 230 kV | Plattsburg 115 kV | xmfr | W | 2021 | 230/115 | 230/115 | 1 | 249 | 288 | Refurbishment of Plattsburgh Auto Transformer #1 |

| Transmission Owner | Terminals | | Line Length in Miles | In-Service | | Nominal Voltage | | # of ckt | Thermal Ratings (4) | | Project Description / Conductor Size |
|--------------------|----------------------------|----------------------------|----------------------|--------------|------|-----------------|---------|----------|---------------------|---------|--|
| | | | | Date/Yr | | in kV | | | Summer | Winter | |
| | | | | Prior to (2) | Year | Operating | Design | | | | |
| NYPA | Astoria Annex | Astoria Annex | Shunt Reactor | W | 2021 | 345 | 345 | 2 | TBD | TBD | |
| O & R | Lovett 345 kV Station (New | Lovett | xfmr | S | 2021 | 345/138 | 345/138 | 1 | 562 MVA | 562 MVA | Transformer |
| O & R | Little Tor | - | Cap Bank | S | 2021 | 138 | 138 | 1 | 32 MVAR | 32 MVAR | Capacitor bank |
| O & R | Deerpak | Port Jervis | 2 | S | 2021 | 69 | 69 | 1 | | 1604 | |
| O & R | Westtown | Port Jervis | 7 | S | 2021 | 69 | 69 | 1 | | 1604 | |
| O & R/ConEd | Ladentown | Buchanan | -9.5 | S | 2021 | 345 | 345 | 1 | 3000 | 3211 | 2-2493 ACAR |
| O & R/ConEd | Ladentown | Lovett 345 kV Station (New | 5.5 | S | 2021 | 345 | 345 | 1 | 3000 | 3211 | 2-2493 ACAR |
| O & R/ConEd | Lovett 345 kV Station (New | Buchanan | 4 | S | 2021 | 345 | 345 | 1 | 3000 | 3211 | 2-2493 ACAR |
| CHGE | St. Pool | High Falls | 5.61 | W | 2022 | 115 | 115 | 1 | 1010 | 1245 | 1-795 ACSR |
| CHGE | High Falls | Kerhonkson | 10.03 | W | 2022 | 115 | 115 | 1 | 1010 | 1245 | 1-795 ACSR |
| CHGE | Modena | Galeville | 4.62 | W | 2022 | 115 | 115 | 1 | 1010 | 1245 | 1-795 ACSR |
| CHGE | Galeville | Kerhonkson | 8.96 | W | 2022 | 115 | 115 | 1 | 1010 | 1245 | 1-795 ACSR |
| CHGE | Hurley Ave | Saugerties | 11.40 | W | 2022 | 69 | 115 | 1 | 1114 | 1359 | 1-795 ACSR |
| CHGE | Kerhonkson | Kerhonkson | xfmr | W | 2022 | 115/69 | 115/69 | 1 | 564 | 728 | Add Transformer 3 |
| CHGE | Kerhonkson | Kerhonkson | xfmr | W | 2022 | 115/69 | 115/69 | 1 | 564 | 728 | Add Transformer 4 |
| CHGE | Rock Tavern | Sugarloaf | 12.10 | W | 2022 | 115 | 115 | 1 | N/A | N/A | Retire SL Line |
| CHGE | Sugarloaf | NY/NJ State Line | 10.30 | W | 2022 | 115 | 115 | 2 | N/A | N/A | Retire SD/SJ Lines |
| NGRID | South Oswego | Indeck (#6) | - | S | 2022 | 115 | 115 | 1 | - | - | Install High Speed Clearing on Line #6 |
| NGRID | Porter | Porter | - | S | 2022 | 230 | 230 | | N/A | N/A | Porter 230kV upgrades |
| NGRID | Watertown | Watertown | | S | 2022 | 115 | 115 | | N/A | N/A | New Distribution Station at Watertown |

| Transmission Owner | Terminals | | Line Length in Miles | In-Service Date/Yr | | Nominal Voltage in kV | | # of ckts | Thermal Ratings (4) | | Project Description / Conductor Size |
|--------------------|---------------------|------------------------|----------------------|--------------------|------|-----------------------|----------|-----------|---------------------|---------|---|
| | | | | Prior to (2) | Year | Operating | Design | | Summer | Winter | |
| | | | | | | | | | | | |
| NGRID | Golah | Golah | xfmr | S | 2022 | 69 | 69 | | 50MVA | 50MVA | Replace Golah 69/34.5kV Transformer |
| NGRID | Niagara | Packard | 3.7 | S | 2022 | 115 | 115 | 1 | 344MVA | 449MVA | Replace 3.7 miles of 191 line |
| NGRID | Lockport | Mortimer | 56.5 | S | 2022 | 115 | 115 | 3 | - | - | Replace Cables Lockport-Mortimer #111, 113, 114 |
| NGRID | Niagara | Packard | 3.7 | W | 2022 | 115 | 115 | 2 | 344MVA | 449MVA | Replace 3.7 miles of 193 and 194 lines |
| NGRID | Gardenville | Big Tree | 6.3 | W | 2022 | 115 | 115 | 1 | 221MVA | 221MVA | Gardenville-Arcade #151 Loop-in-and-out of NYSEG Big Tree |
| NGRID | Big Tree | Arcade | 28.6 | W | 2022 | 115 | 115 | 1 | 129MVA | 156MVA | Gardenville-Arcade #151 Loop-in-and-out of NYSEG Big Tree |
| NGRID | Coffeen | Coffeen | - | S | 2022 | 115 | 115 | - | TBD | TBD | Terminal equipment replacements |
| NGRID | Browns Falls | Browns Falls | - | S | 2022 | 115 | 115 | - | TBD | TBD | Terminal equipment replacements |
| NGRID | Taylorville | Taylorville | - | S | 2022 | 115 | 115 | - | TBD | TBD | Terminal equipment replacements |
| NYPA | Niagara 345 kV | Niagara 230 kV | xfmr | W | 2022 | 345/230 | 345/230 | 1 | TBD | TBD | Replacement of Niagara AutoTransformer #3 |
| NYSEG | South Perry | South Perry | xfmr | W | 2022 | 115/34.5 | 115/34.5 | 1 | 59 MVA | 67 MVA | Transformer #3 |
| NYSEG | South Perry | South Perry | xfmr | W | 2022 | 230/115 | 230/115 | 1 | 246 MVA | 291 MVA | Transformer |
| NYSEG | Fraser | Fraser | xfmr | W | 2022 | 345/115 | 345/115 | 1 | 305 MVA | 364 MVA | Transformer #2 and Station Reconfiguration |
| NYSEG | Fraser 115 | Fraser 115 | Rebuild | W | 2022 | 115 | 115 | | N/A | N/A | Station Rebuild to 4 bay BAAH |
| NYSEG | Delhi | Delhi | Removal | W | 2022 | 115 | 115 | | N/A | N/A | Remove 115 substation and terminate existing lines to Fraser 115 (short distance) |
| NYSEG | Erie Street Rebuild | Erie Street Rebuild | Rebuild | W | 2022 | 115 | 115 | | | | Station Rebuild |
| NYSEG | Big Tree Road | Big Tree Road | Rebuild | W | 2022 | 115 | 115 | | | | Station Rebuild |
| NYSEG | Meyer | Meyer | xfmr | W | 2022 | 115/34.5 | 115/34.5 | 2 | 59.2MVA | 66.9MVA | Transformer #2 |
| O & R | Ramapo (NY) | South Mahwah | 5.50 | W | 2022 | 138 | 138 | 2 | 1980 | 2120 | 1272 ACSS |
| RGE | Station 168 | Mortimer (NG Trunk #2) | 26.4 | W | 2022 | 115 | 115 | 1 | 145 MVA | 176 MVA | Station 168 Reinforcement Project |

| Transmission Owner | Terminals | | Line Length in Miles | In-Service | | Nominal Voltage | | # of ckt | Thermal Ratings (4) | | Project Description / Conductor Size |
|--------------------|---------------------|-------------------------|----------------------|--------------|------|-----------------|----------|----------|---------------------|---------|---|
| | | | | Date/Yr | | in kV | | | Summer | Winter | |
| | | | | Prior to (2) | Year | Operating | Design | | | | |
| RGE | Station 168 | Elbridge (NG Trunk # 6) | 45.5 | W | 2022 | 115 | 115 | 1 | 145 MVA | 176 MVA | Station 168 Reinforcement Project |
| RGE | Station 127 | Station 127 | xmfr | W | 2022 | 115/34.5 | 115/34.5 | 1 | 75MVA | 75MVA | Transformer #2 |
| CHGE | Saugerties | North Catskill | 12.46 | W | 2023 | 69 | 115 | 1 | 1114 | 1359 | 1-795 ACSR |
| NGRID | Cortland | Clarks Corners | 0.2 | S | 2023 | 115 | 115 | 1 | 147MVA | 170MVA | Replace 0.2 miles of 1(716) line and series equipment |
| NGRID | Maplewood | Menands | 3 | S | 2023 | 115 | 115 | 1 | 220 MVA | 239 MVA | Reconductor approx 3 miles of 115kV Maplewood – Menands #19 |
| NGRID | Maplewood | Reynolds | 3 | S | 2023 | 115 | 115 | 1 | 217 MVA | 265 MVA | Reconductor approx 3 miles of 115kV Maplewood – Reynolds Road #31 |
| NGRID | Elm St | Elm St | - | S | 2023 | 230/23 | 230/23 | - | 118MVA | 133MVA | Replace TR2 as failure |
| NGRID | Packard | Huntley | 9.1 | W | 2023 | 115 | 115 | 1 | 262MVA | 275MVA | Walck-Huntley #133, Packard-Huntley #130 Reconductor |
| NGRID | Walck | Huntley | 9.1 | W | 2023 | 115 | 115 | 1 | 262MVA | 275MVA | Walck-Huntley #133, Packard-Huntley #130 Reconductor |
| NGRID | Kensington Terminal | Kensington Terminal | - | W | 2023 | 115/23 | 115/23 | - | 50MVA | 50MVA | Replace TR4 and TR5 |
| NGRID | Malone | Malone | - | S | 2023 | 115 | 115 | - | TBD | TBD | Station Rebuild |
| NGRID | Taylorville | Boonville | - | S | 2023 | 115 | 115 | - | TBD | TBD | Install series reactors on the 5 and 6 lines. Size TBD |
| NYPA | Moses | Adirondack | 78 | S | 2023 | 230 | 345 | 2 | 1088 | 1329 | Replace 78 miles of both Moses-Adirondack 1&2 |
| NYPA | Niagara 345 kV | Niagara 230 kV | xmfr | W | 2023 | 345/230 | 345/230 | 1 | TBD | TBD | Replacement of Niagara AutoTransformer #5 |
| NYSEG | Gardenville | Gardenville | xmfr | W | 2023 | 230/115 | 230/115 | 1 | 316 MVA | 370 MVA | NYSEG Transformer #3 and Station Reconfiguration |
| NYSEG | Wood Street | Wood Street | xmfr | W | 2023 | 345/115 | 345/115 | 1 | 327 MVA | 378 MVA | Transformer #3 |
| O & R | Burns | West Nyack | 5.00 | S | 2023 | 138 | 138 | 1 | 940 | 940 | UG Cable |
| O & R | Shoemaker | Pocatello | 2.00 | W | 2023 | 69 | 69 | 1 | 1604 | 1723 | 795 ACSS |
| O & R | Sugarloaf | Shoemaker | 12.00 | W | 2023 | 69 | 138 | 2 | 1062 | 1141 | 397 ACSS |
| ConEd | Hudson Ave East | New Vinegar Hill | xmfrs/PARs/Federals | S | 2024 | 138/27 | 138/27 | | N/A | N/A | New Hudson Ave Distribution Switching Station |

| Transmission Owner | Terminals | | Line Length in Miles | In-Service | | Nominal Voltage | | # of ckt | Thermal Ratings (4) | | Project Description / Conductor Size |
|--------------------|---------------------------|----------------------------|----------------------|--------------|------|-----------------|--------|----------|---------------------|---------|---|
| | | | | Date/Yr | | in kV | | | Summer | Winter | |
| | | | | Prior to (2) | Year | Operating | Design | | | | |
| ConEd | Farragut | Farragut | Reconfiguration | S | 2024 | 138 | 138 | | N/A | N/A | Install PASS Breaker |
| NGRID | Dunkirk | Laona | - | S | 2024 | 115 | 115 | 2 | N/A | N/A | Remove series reactors from New Road Switch Station and install new to Moons Switch Station |
| NGRID | Laona | Moons | - | S | 2024 | 115 | 115 | 2 | N/A | N/A | Remove series reactors from New Road Switch Station and install new to Moons Switch Station |
| NGRID | Golah | Golah | Reconfiguration | S | 2024 | 115 | 115 | | - | - | Add a Golah 115kV bus tie breaker |
| NGRID | Dunkirk | Dunkirk | - | S | 2024 | 115 | 115 | | N/A | N/A | Rebuild of Dunkirk 115kV Station |
| NGRID | Gardenville | Dunkirk | 20.5 | S | 2024 | 115 | 115 | 2 | 1105 | 1346 | Replace 20.5 miles of 141 and 142 lines |
| NGRID | Homer Hill | Homer Hill | - | S | 2024 | 115 | 115 | - | 116MVA | 141MVA | Homer Hill Replace five OCB |
| NGRID | Inghams | Saint Johnsville | 2.94 | W | 2024 | 115 | 115 | 1 | 1114 | 1359 | Reconductor 2.94mi of 2/0 + 4/0 Cu (of 7.11mi total) to 795 ACSR |
| NGRID | Inghams 115kV | Inghams 115kV | Breaker | W | 2024 | 115 | 115 | - | 2000 | 2000 | Add series breaker to Inghams R15 (Inghams - Meco #15 115kV) |
| NGRID | Schenectady International | Rotterdam | 0.93 | W | 2024 | 69 | 115 | 1 | 1114 | 1359 | Reconductor 0.93mi of 4/0 Cu + 336.4 ACSR (of 21.08mi total) to 795 ACSR |
| NGRID | Rotterdam | Schoharie | 0.93 | W | 2024 | 69 | 115 | 1 | 1114 | 1359 | Reconductor 0.93mi of 4/0 Cu (of 21.08mi total) to 795 ACSR |
| NYSEG | Westover 115 | Westover | Removal | W | 2024 | 115 | 115 | | N/A | N/A | Remove 115 substation and terminate existing lines to Oakdale 115 (short distance) |
| O & R | Montvale (RECO) | - | Cap Bank | S | 2024 | 69 | 69 | 1 | 32 MVAR | 32 MVAR | Capacitor bank |
| O & R | Ramapo | Sugarloaf | 17.00 | W | 2024 | 138 | 138 | 1 | 1980 | 2120 | 1272 ACSS |
| O & R | Burns | Corporate Drive | 5.00 | W | 2024 | 138 | 138 | 1 | 1980 | 2120 | 1272 ACSS |
| RGE | Station 418 | Station 48 | 7.6 | W | 2024 | 115 | 115 | 1 | 175 MVA | 225 MVA | New 115kV Line |
| RGE | Station 82 | Station 251 (Upgrade Line) | | W | 2024 | 115 | 115 | 1 | 400MVA | 400MVA | Line Upgrade |
| RGE | Mortimer | Station 251 (Upgrade Line) | 1.00 | W | 2024 | 115 | 115 | 1 | 400MVA | 400MVA | Line Upgrade |
| LIPA | Southampton | Deerfield | 4.00 | S | 2025 | 69 | 138 | 1 | 1171 | 1171 | 2000 SQMM XLPE |
| NGRID | Stoner | Rotterdam | 9.81 | W | 2025 | 115 | 115 | 1 | 1398 | 1708 | Reconductor 9.81mi of 4/0 Cu + 336.4 ACSR (of 23.12mi total) to 1192.5 ACSR |

| Transmission Owner | Terminals | | Line Length in Miles | In-Service Date/Yr | | Nominal Voltage in kV | | # of ckts | Thermal Ratings (4) | | Project Description / Conductor Size |
|--------------------|-----------------|-----------------------|----------------------|--------------------|------|-----------------------|--------|-----------|---------------------|---------|--|
| | | | | Prior to (2) | Year | Operating | Design | | Summer | Winter | |
| | | | | NGRID | Meco | Rotterdam | 9.81 | | W | 2025 | |
| LIPA | Syosset | Shore Rd | 11.00 | S | 2026 | 138 | 138 | 1 | 1171 | 1171 | 2000 SQMM XLPE |
| LIPA | Syosset | Shore Rd | Phase Shifter | S | 2026 | 138 | 138 | 1 | TBD | TBD | Phase Shifter |
| NGRID | Niagara | Gardenville | 26.3 | S | 2026 | 115 | 115 | 1 | 275MVA | 350MVA | Packard-Erie / Niagara-Gardenville Reconfiguration |
| NGRID | Packard | Gardenville | 28.2 | S | 2026 | 115 | 115 | 2 | 168MVA | 211 MVA | Packard-Gardenville Reactors, Packard-Erie / Niagara-Gardenville Reconfiguration |
| NGRID | Mortimer | Pannell | 15.7 | S | 2026 | 115 | 115 | 2 | 221MVA | 270MVA | |
| NGRID/NYSEG | Erie St | Gardenville | 5.5 | S | 2026 | 115 | 115 | 1 | 139MVA | 179MVA | Packard-Erie / Niagara-Gardenville Reconfiguration, Gardenville add breakers |
| O & R | West Nyack | West Nyack | - | S | 2026 | 138 | 138 | 1 | | | Station Reconfiguration |
| O & R | West Nyack (NY) | Harings Corner (RECO) | 7.00 | W | 2026 | 69 | 138 | 1 | 1604 | 1723 | 795 ACSR |

| Transmission Owner | Terminals | | Line Length in Miles | In-Service | | Nominal Voltage | | # of ckts | Thermal Ratings (4) | | Project Description / Conductor Size |
|---|---------------------------|--------------------------------|----------------------|--------------|------|-----------------|---------|-----------|---------------------|----------|--|
| | | | | Date/Yr | | in kV | | | Summer | Winter | |
| | | | | Prior to (2) | Year | Operating | Design | | | | |
| 2020 Gold Book - Firm Plans (5) (included in FERC 715 Base Case) | | | | | | | | | | | |
| NGRID | Lasher Rd (New Station) | Rotterdam | 11.05 | S | 2020 | 115 | 115 | 1 | 2080 | 2392 | New Lasher Rd Switching Station |
| NGRID | Spier | Luther Forest (#302) | -34.21 | S | 2020 | 115 | 115 | 1 | 916 | 1070 | New Lasher Rd Switching Station |
| NGRID | Spier | Lasher Rd (New Station) (#302) | 21.72 | S | 2020 | 115 | 115 | 1 | 916 | 1118 | New Lasher Rd Switching Station |
| NGRID | Lasher Rd (New Station) | Luther Forest | 12.49 | S | 2020 | 115 | 115 | 1 | 990 | 1070 | New Lasher Rd Switching Station |
| NGRID | Rotterdam | Rotterdam | - | S | 2020 | 115 | 115 | 2 | N/A | N/A | Install Series Reactors at Rotterdam Station on lines 17 & 19 |
| NGRID | Huntley | Lockport | 6.9 | S | 2020 | 115 | 115 | 2 | 1303 | 1380 | Replace 6.9 miles of 36 and 37 lines |
| NGRID | Two Mile Creek | Two Mile Creek | | S | 2020 | 115 | 115 | | N/A | N/A | New Distribution Station at Two Mile Creek |
| NGRID | Maple Ave | Maple Ave | | S | 2020 | 115 | 115 | | N/A | N/A | New Distribution Station at Maple Ave |
| NGRID | Randall Rd | Randall Rd | | S | 2020 | 115 | 115 | | N/A | N/A | New Distribution Station at Randall Road |
| NGRID | GE | Geres Lock | 7.14 | S | 2020 | 115 | 115 | 1 | 785 | 955 | Reconductoring 4/OCU & 336 ACSR to 477 ACCR (Line #8) |
| NGRID | Gardenville 115kV | Gardenville 115kV | - | S | 2020 | - | - | - | - | - | Rebuild of Gardenville 115kV Station to full breaker and a half |
| NGRID | Rotterdam | Woodlawn | 7 | S | 2020 | 115 | 115 | 1 | | | Replace 7.0 miles of mainly 4/0 Cu conductor with 795kcmil ACSR 26/7 |
| NGRID | Gardenville 230kV | Gardenville 115kV | xfmr | S | 2020 | 230/115 | 230/115 | - | 347 MVA | 422 MVA | Replacement of 230/115kV TB#4 stepdown with larger unit |
| NGRID | Oswego | Oswego | - | W | 2020 | 115 | 115 | | N/A | N/A | Rebuild of Oswego 115kV Station |
| NYP&A | Fraser Annex | Fraser Annex | SSR Detection | S | 2020 | 345 | 345 | 1 | 1793 MVA | 1793 MVA | MSSC SSR Detection Project |
| NYP&A | Niagara | Rochester | -70.20 | W | 2020 | 345 | 345 | 1 | 2177 | 2662 | 2-795 ACSR |
| NYP&A | Somerset | Rochester | -44.00 | W | 2020 | 345 | 345 | 1 | 2177 | 2662 | 2-795 ACSR |
| NYP&A | Niagara | Station 255 (New Station) | 66.40 | W | 2020 | 345 | 345 | 1 | 2177 | 2662 | 2-795 ACSR |
| NYP&A | Somerset | Station 255 (New Station) | 40.20 | W | 2020 | 345 | 345 | 1 | 2177 | 2662 | 2-795 ACSR |
| NYP&A | Station 255 (New Station) | Rochester | 3.80 | W | 2020 | 345 | 345 | 2 | 2177 | 2662 | 2-795 ACSR |

| Transmission Owner | Terminals | | Line Length in Miles | In-Service | | Nominal Voltage | | # of ckts | Thermal Ratings (4) | | Project Description / Conductor Size |
|---|---------------------------|---------------------------------|---------------------------------------|--------------|------|-----------------|----------|-----------|---------------------|--------------|--|
| | | | | Date/Yr | | in kV | | | Summer | Winter | |
| | | | | Prior to (2) | Year | Operating | Design | | | | |
| 2020 Gold Book - Firm Plans (5) (included in FERC 715 Base Case) | | | | | | | | | | | |
| NYPA | Niagara 230 kV | Niagara 230 kV | Breaker | W | 2020 | 230 | 230 | 1 | N/A | N/A | Add a new breaker |
| NYPA | Niagara 230 kV | Niagara 115 kV | Autotransformer | S | 2020 | 230 | 115 | 1 | 240 MVA | 240 MVA | Replace Niagara AT #1 |
| NYPA | Astoria 138 kV | Astoria 13.8 kV | Astoria CC GSU Refurbishment | W | 2020 | 138 | 18 | 1 | 234 | 234 | Astoria CC GSU Refurbishment |
| NYSEG | Watercure Road | Watercure Road | xfmr | W | 2020 | 345/230 | 345/230 | 1 | 426 MVA | 494 MVA | Transformer #2 and Station Reconfiguration |
| NYSEG | Willet | Willet | xfmr | W | 2020 | 115/34.5 | 115/34.5 | 1 | 39 MVA | 44 MVA | Transformer #2 |
| NYSEG | Coddington | E. Ithaca (to Coddington) | 8.07 | W | 2020 | 115 | 115 | 1 | 307 MVA | 307 MVA | 665 ACCR |
| O & R | West Nyack | West Nyack | Cap Bank | S | 2020 | 138 | 138 | 1 | - | - | Capacitor Bank |
| O & R | Harings Corner (RECO) | Closter (RECO) | 3.20 | S | 2020 | 69 | 69 | 1 | 1098 | 1312 | UG Cable |
| O & R | Ramapo | Ramapo | xfmr | S | 2020 | 345/138 | 345/138 | 1 | 731 | 731 | - |
| RGE | Station 122-Pannell-PC1 | Station 122-Pannell-PC1 and PC2 | | S | 2020 | 345 | 345 | 1 | 1314 MVA-LTE | 1314 MVA-LTE | Relay Replacement |
| RGE | Station 262 | Station 23 | 1.46 | W | 2020 | 115 | 115 | 1 | 2008 | 2008 | Underground Cable |
| RGE | Station 33 | Station 262 | 2.97 | W | 2020 | 115 | 115 | 1 | 2008 | 2008 | Underground Cable |
| RGE | Station 262 | Station 262 | xfmr | W | 2020 | 115/34.5 | 115/34.5 | 1 | 58.8MVA | 58.8MVA | Transformer |
| RGE | Station 255 (New Station) | Rochester | 3.80 | W | 2020 | 345 | 345 | 1 | 2177 | 2662 | 2-795 ACSR |
| RGE | Station 255 (New Station) | Station 255 (New Station) | xfmr | W | 2020 | 345/115 | 345/115 | 1 | 400 MVA | 450 MVA | Transformer |
| RGE | Station 255 (New Station) | Station 255 (New Station) | xfmr | W | 2020 | 345/115 | 345/115 | 2 | 400 MVA | 450 MVA | Transformer |
| RGE | Station 255 (New Station) | Station 418 | 9.60 | W | 2020 | 115 | 115 | 1 | 1506 | 1807 | New 115kV Line |
| RGE | Station 255 (New Station) | Station 23 | 11.10 | W | 2020 | 115 | 115 | 1 | 1506 | 1807 | New 115kV Line |
| CHGE | Hurley Avenue | Leeds | Static synchronous series compensator | S | 2021 | 345 | 345 | 1 | 2336 | 2866 | 21% Compensation |
| LIPA | Valley Stream | East Garden City | 7.36 | S | 2021 | 138 | 138 | 1 | 1171 | 1171 | 2000 SQMM XLPE |

| Transmission Owner | Terminals | | Line Length in Miles | In-Service | | Nominal Voltage | | # of ckts | Thermal Ratings (4) | | Project Description / Conductor Size |
|---|--------------------|--------------------|----------------------|--------------|------|-----------------|----------|-----------|---------------------|---------|--|
| | | | | Date/Yr | | in kV | | | Summer | Winter | |
| | | | | Prior to (2) | Year | Operating | Design | | | | |
| 2020 Gold Book - Firm Plans (5) (included in FERC 715 Base Case) | | | | | | | | | | | |
| LIPA | Amagansett | Montauk | -13.00 | S | 2021 | 23 | 23 | 1 | 577 | 657 | 750 kcmil CU |
| LIPA | Amagansett | Navy Road | 12.74 | S | 2021 | 23 | 23 | 1 | 577 | 657 | 750 kcmil CU |
| LIPA | Navy Road | Montauk | 0.26 | S | 2021 | 23 | 23 | 1 | 577 | 657 | 750 kcmil CU |
| LIPA | Riverhead | Wildwood | 10.63 | S | 2021 | 138 | 138 | 1 | 1399 | 1709 | 1192ACSR |
| LIPA | Riverhead | Canal | 16.49 | S | 2021 | 138 | 138 | 1 | 1000 | 1110 | 2368 KCMIL (1200 mm ²) Copper XLPE |
| NGRID | Clay | Dewitt | 10.24 | S | 2021 | 115 | 115 | 1 | 220MVA | 268MVA | Reconductor 4/0 CU to 795ACSR |
| NGRID | Clay | Teall | 12.75 | S | 2021 | 115 | 115 | 1 | 220 MVA | 268MVA | Reconductor 4/0 CU to 795ACSR |
| NGRID | Gardenville 230kV | Gardenville 115kV | xfmr | S | 2021 | 230/115 | 230/115 | - | 347 MVA | 422 MVA | Replacement of 230/115kV TB#3 stepdown with larger unit |
| NGRID | Huntley 115kV | Huntley 115kV | - | S | 2021 | 230 | 230 | - | N/A | N/A | Rebuild of Huntley 115kV Station |
| NGRID | Mortimer | Mortimer | xfmr | S | 2021 | 115 | 115 | | 50MVA | 50MVA | Replace Mortimer 115/69kV Transformer |
| NGRID | Mortimer | Mortimer | - | S | 2021 | 115 | 115 | | N/A | N/A | Second 115kV Bus Tie Breaker at Mortimer Station |
| NGRID | New Bethlehem | New Bethlehem | - | S | 2021 | 115 | 115 | | N/A | N/A | New Bethlehem 115/13.2kV station |
| NGRID | New Cicero | New Cicero | | S | 2021 | 115 | 115 | | N/A | N/A | New Distribution Station at New Cicero |
| NGRID | Mountain | Lockport | 0.08 | S | 2021 | 115 | 115 | 2 | 174MVA | 199MVA | Mountain-Lockport 103/104 Bypass |
| NGRID | Royal Ave | Royal Ave | - | S | 2021 | 115/13.2 | 115/13.2 | - | - | - | Install new 115-13.2 kV distribution substation in Niagara Falls (Royal Ave) |
| NGRID | Niagara | Packard | 3.4 | W | 2021 | 115 | 115 | 1 | 344MVA | 449MVA | Replace 3.4 miles of 192 line |
| NYPA | Moses 230 kV | Adirondack 230 kV | Series Compensation | S | 2021 | 230 | 230 | - | ±13.2kV | ±13.2kV | Voltage Source Series Compensation |
| NYPA | St. Lawrence 230kV | St. Lawrence 115kV | xfmr | S | 2021 | 230/115 | 230/115 | 1 | TBD | TBD | Replacement of St. Lawrence AutoTransformer #2 |
| NYPA | Plattsburg 230 kV | Plattsburg 115 kV | xfmr | W | 2021 | 230/115 | 230/115 | 1 | 249 | 288 | Refurbishment of Plattsburgh Auto Transformer #1 |

| Transmission Owner | Terminals | | Line Length in Miles | In-Service Date/Yr | | Nominal Voltage in kV | | # of ckts | Thermal Ratings (4) | | Project Description / Conductor Size |
|--------------------|-------------------------------------|-------------------------------------|----------------------|---|------|-----------------------|---------|-----------|---------------------|---------|--|
| | | | | Prior to (2) | Year | Operating | Design | | Summer | Winter | |
| | | | | 2020 Gold Book - Firm Plans (5) (included in FERC 715 Base Case) | | | | | | | |
| NYP&A | Astoria Annex | Astoria Annex | Shunt Reactor | W | 2021 | 345 | 345 | 2 | TBD | TBD | |
| O & R | Lovett 345 kV Station (New Station) | Lovett | xfmr | S | 2021 | 345/138 | 345/138 | 1 | 562 MVA | 562 MVA | Transformer |
| O & R | Little Tor | - | Cap Bank | S | 2021 | 138 | 138 | 1 | 32 MVAR | 32 MVAR | Capacitor bank |
| O & R | Deerpak | Port Jervis | 2 | S | 2021 | 69 | 69 | 1 | | 1604 | |
| O & R | Westtown | Port Jervis | 7 | S | 2021 | 69 | 69 | 1 | | 1604 | |
| O & R/ConEd | Ladentown | Buchanan | -9.5 | S | 2021 | 345 | 345 | 1 | 3000 | 3211 | 2-2493 ACAR |
| O & R/ConEd | Ladentown | Lovett 345 kV Station (New Station) | 5.5 | S | 2021 | 345 | 345 | 1 | 3000 | 3211 | 2-2493 ACAR |
| O & R/ConEd | Lovett 345 kV Station (New Station) | Buchanan | 4 | S | 2021 | 345 | 345 | 1 | 3000 | 3211 | 2-2493 ACAR |
| CHGE | St. Pool | High Falls | 5.61 | W | 2022 | 115 | 115 | 1 | 1010 | 1245 | 1-795 ACSR |
| CHGE | High Falls | Kerhonkson | 10.03 | W | 2022 | 115 | 115 | 1 | 1010 | 1245 | 1-795 ACSR |
| CHGE | Modena | Galeville | 4.62 | W | 2022 | 115 | 115 | 1 | 1010 | 1245 | 1-795 ACSR |
| CHGE | Galeville | Kerhonkson | 8.96 | W | 2022 | 115 | 115 | 1 | 1010 | 1245 | 1-795 ACSR |
| CHGE | Hurley Ave | Saugerties | 11.40 | W | 2022 | 69 | 115 | 1 | 1114 | 1359 | 1-795 ACSR |
| CHGE | Kerhonkson | Kerhonkson | xfmr | W | 2022 | 115/69 | 115/69 | 1 | 564 | 728 | Add Transformer 3 |
| CHGE | Kerhonkson | Kerhonkson | xfmr | W | 2022 | 115/69 | 115/69 | 1 | 564 | 728 | Add Transformer 4 |
| CHGE | Rock Tavern | Sugarloaf | 12.10 | W | 2022 | 115 | 115 | 1 | N/A | N/A | Retire SL Line |
| CHGE | Sugarloaf | NY/NJ State Line | 10.30 | W | 2022 | 115 | 115 | 2 | N/A | N/A | Retire SD/SJ Lines |
| NGRID | South Oswego | Indeck (#6) | - | S | 2022 | 115 | 115 | 1 | - | - | Install High Speed Clearing on Line #6 |
| NGRID | Porter | Porter | - | S | 2022 | 230 | 230 | | N/A | N/A | Porter 230kV upgrades |
| NGRID | Watertown | Watertown | | S | 2022 | 115 | 115 | | N/A | N/A | New Distribution Station at Watertown |

| Transmission Owner | Terminals | | Line Length in Miles | In-Service | | Nominal Voltage | | # of ckts | Thermal Ratings (4) | | Project Description / Conductor Size |
|---|---------------------|------------------------|----------------------|--------------|------|-----------------|----------|-----------|---------------------|---------|---|
| | | | | Date/Yr | | in kV | | | Summer | Winter | |
| | | | | Prior to (2) | Year | Operating | Design | | | | |
| 2020 Gold Book - Firm Plans (5) (included in FERC 715 Base Case) | | | | | | | | | | | |
| NGRID | Golah | Golah | xfmr | S | 2022 | 69 | 69 | | 50MVA | 50MVA | Replace Golah 69/34.5kV Transformer |
| NGRID | Niagara | Packard | 3.7 | S | 2022 | 115 | 115 | 1 | 344MVA | 449MVA | Replace 3.7 miles of 191 line |
| NGRID | Lockport | Mortimer | 56.5 | S | 2022 | 115 | 115 | 3 | - | - | Replace Cables Lockport-Mortimer #111, 113, 114 |
| NGRID | Niagara | Packard | 3.7 | W | 2022 | 115 | 115 | 2 | 344MVA | 449MVA | Replace 3.7 miles of 193 and 194 lines |
| NGRID | Gardenville | Big Tree | 6.3 | W | 2022 | 115 | 115 | 1 | 221MVA | 221MVA | Gardenville-Arcade #151 Loop-in-and-out of NYSEG Big Tree |
| NGRID | Big Tree | Arcade | 28.6 | W | 2022 | 115 | 115 | 1 | 129MVA | 156MVA | Gardenville-Arcade #151 Loop-in-and-out of NYSEG Big Tree |
| NGRID | Coffeen | Coffeen | - | S | 2022 | 115 | 115 | - | TBD | TBD | Terminal equipment replacements |
| NGRID | Browns Falls | Browns Falls | - | S | 2022 | 115 | 115 | - | TBD | TBD | Terminal equipment replacements |
| NGRID | Taylorville | Taylorville | - | S | 2022 | 115 | 115 | - | TBD | TBD | Terminal equipment replacements |
| NYPA | Niagara 345 kV | Niagara 230 kV | xfmr | W | 2022 | 345/230 | 345/230 | 1 | TBD | TBD | Replacement of Niagara AutoTransformer #3 |
| NYSEG | South Perry | South Perry | xfmr | W | 2022 | 115/34.5 | 115/34.5 | 1 | 59 MVA | 67 MVA | Transformer #3 |
| NYSEG | South Perry | South Perry | xfmr | W | 2022 | 230/115 | 230/115 | 1 | 246 MVA | 291 MVA | Transformer |
| NYSEG | Fraser | Fraser | xfmr | W | 2022 | 345/115 | 345/115 | 1 | 305 MVA | 364 MVA | Transformer #2 and Station Reconfiguration |
| NYSEG | Fraser 115 | Fraser 115 | Rebuild | W | 2022 | 115 | 115 | | N/A | N/A | Station Rebuild to 4 bay BAAH |
| NYSEG | Delhi | Delhi | Removal | W | 2022 | 115 | 115 | | N/A | N/A | Remove 115 substation and terminate existing lines to Fraser 115 (short distance) |
| NYSEG | Erie Street Rebuild | Erie Street Rebuild | Rebuild | W | 2022 | 115 | 115 | | | | Station Rebuild |
| NYSEG | Big Tree Road | Big Tree Road | Rebuild | W | 2022 | 115 | 115 | | | | Station Rebuild |
| NYSEG | Meyer | Meyer | xfmr | W | 2022 | 115/34.5 | 115/34.5 | 2 | 59.2MVA | 66.9MVA | Transformer #2 |
| O & R | Ramapo (NY) | South Mahwah (RECO) | 5.50 | W | 2022 | 138 | 138 | 2 | 1980 | 2120 | 1272 ACSS |
| RGE | Station 168 | Mortimer (NG Trunk #2) | 26.4 | W | 2022 | 115 | 115 | 1 | 145 MVA | 176 MVA | Station 168 Reinforcement Project |

| Transmission Owner | Terminals | | Line Length in Miles | In-Service | | Nominal Voltage | | # of ckts | Thermal Ratings (4) | | Project Description / Conductor Size |
|---|---------------------|---|----------------------|--------------|------|-----------------|----------|-----------|---------------------|---------|---|
| | | | | Date/Yr | | in kV | | | Summer | Winter | |
| | | | | Prior to (2) | Year | Operating | Design | | | | |
| 2020 Gold Book - Firm Plans (5) (included in FERC 715 Base Case) | | | | | | | | | | | |
| RGE | Station 168 | Elbridge (NG Trunk # 6) | 45.5 | W | 2022 | 115 | 115 | 1 | 145 MVA | 176 MVA | Station 168 Reinforcement Project |
| RGE | Station 127 | Station 127 | xfmr | W | 2022 | 115/34.5 | 115/34.5 | 1 | 75MVA | 75MVA | Transformer #2 |
| CHGE | Saugerties | North Catskill | 12.46 | W | 2023 | 69 | 115 | 1 | 1114 | 1359 | 1-795 ACSR |
| NGRID | Cortland | Clarks Corners | 0.2 | S | 2023 | 115 | 115 | 1 | 147MVA | 170MVA | Replace 0.2 miles of 1(716) line and series equipment |
| NGRID | Maplewood | Menands | 3 | S | 2023 | 115 | 115 | 1 | 220 MVA | 239 MVA | Reconductor approx 3 miles of 115kV Maplewood – Menands #19 |
| NGRID | Maplewood | Reynolds | 3 | S | 2023 | 115 | 115 | 1 | 217 MVA | 265 MVA | Reconductor approx 3 miles of 115kV Maplewood – Reynolds Road #31 |
| NGRID | Elm St | Elm St | - | S | 2023 | 230/23 | 230/23 | - | 118MVA | 133MVA | Replace TR2 as failure |
| NGRID | Packard | Huntley | 9.1 | W | 2023 | 115 | 115 | 1 | 262MVA | 275MVA | Walck-Huntley #133, Packard-Huntley #130 Reconductor |
| NGRID | Walck | Huntley | 9.1 | W | 2023 | 115 | 115 | 1 | 262MVA | 275MVA | Walck-Huntley #133, Packard-Huntley #130 Reconductor |
| NGRID | Kensington Terminal | Kensington Terminal | - | W | 2023 | 115/23 | 115/23 | - | 50MVA | 50MVA | Replace TR4 and TR5 |
| NGRID | Malone | Malone | - | S | 2023 | 115 | 115 | - | TBD | TBD | Station Rebuild |
| NGRID | Taylorville | Boonville | - | S | 2023 | 115 | 115 | - | TBD | TBD | Install series reactors on the 5 and 6 lines. Size TBD |
| NYP&A | Moses | Adirondack | 78 | S | 2023 | 230 | 345 | 2 | 1088 | 1329 | Replace 78 miles of both Moses-Adirondack 1&2 |
| NYP&A | Niagara 345 kV | Niagara 230 kV | xfmr | W | 2023 | 345/230 | 345/230 | 1 | TBD | TBD | Replacement of Niagara AutoTransformer #5 |
| NYSEG | Gardenville | Gardenville | xfmr | W | 2023 | 230/115 | 230/115 | 1 | 316 MVA | 370 MVA | NYSEG Transformer #3 and Station Reconfiguration |
| NYSEG | Wood Street | Wood Street | xfmr | W | 2023 | 345/115 | 345/115 | 1 | 327 MVA | 378 MVA | Transformer #3 |
| O & R | Burns | West Nyack | 5.00 | S | 2023 | 138 | 138 | 1 | 940 | 940 | UG Cable |
| O & R | Shoemaker | Pocatello | 2.00 | W | 2023 | 69 | 69 | 1 | 1604 | 1723 | 795 ACSS |
| O & R | Sugarloaf | Shoemaker | 12.00 | W | 2023 | 69 | 138 | 2 | 1062 | 1141 | 397 ACSS |
| ConEd | Hudson Ave East | New Vinegar Hill Distribution Switching Station | xfmrs/PARs/Feeders | S | 2024 | 138/27 | 138/27 | | N/A | N/A | New Hudson Ave Distribution Switching Station |

| Transmission Owner | Terminals | | Line Length in Miles | In-Service | | Nominal Voltage | | # of ckts | Thermal Ratings (4) | | Project Description / Conductor Size |
|---|---------------------------|---------------------------------|----------------------|--------------|------|-----------------|--------|-----------|---------------------|---------|---|
| | | | | Date/Yr | | in kV | | | Summer | Winter | |
| | | | | Prior to (2) | Year | Operating | Design | | | | |
| 2020 Gold Book - Firm Plans (5) (included in FERC 715 Base Case) | | | | | | | | | | | |
| ConEd | Farragut | Farragut | Reconfiguration | S | 2024 | 138 | 138 | | N/A | N/A | Install PASS Breaker |
| NGRID | Dunkirk | Laona | - | S | 2024 | 115 | 115 | 2 | N/A | N/A | Remove series reactors from New Road Switch Station and install new to Moons Switch Station |
| NGRID | Laona | Moons | - | S | 2024 | 115 | 115 | 2 | N/A | N/A | Remove series reactors from New Road Switch Station and install new to Moons Switch Station |
| NGRID | Golah | Golah | Reconfiguration | S | 2024 | 115 | 115 | | - | - | Add a Golah 115kV bus tie breaker |
| NGRID | Dunkirk | Dunkirk | - | S | 2024 | 115 | 115 | | N/A | N/A | Rebuild of Dunkirk 115kV Station |
| NGRID | Gardenville | Dunkirk | 20.5 | S | 2024 | 115 | 115 | 2 | 1105 | 1346 | Replace 20.5 miles of 141 and 142 lines |
| NGRID | Homer Hill | Homer Hill | - | S | 2024 | 115 | 115 | - | 116MVA | 141MVA | Homer Hill Replace five OCB |
| NGRID | Inghams | Saint Johnsville | 2.94 | W | 2024 | 115 | 115 | 1 | 1114 | 1359 | Reconductor 2.94mi of 2/0 + 4/0 Cu (of 7.11mi total) to 795 ACSR |
| NGRID | Inghams 115kV | Inghams 115kV | Breaker | W | 2024 | 115 | 115 | - | 2000 | 2000 | Add series breaker to Inghams R15 (Inghams - Meco #15 115kV) |
| NGRID | Schenectady International | Rotterdam | 0.93 | W | 2024 | 69 | 115 | 1 | 1114 | 1359 | Reconductor 0.93mi of 4/0 Cu + 336.4 ACSR (of 21.08mi total) to 795 ACSR |
| NGRID | Rotterdam | Schoharie | 0.93 | W | 2024 | 69 | 115 | 1 | 1114 | 1359 | Reconductor 0.93mi of 4/0 Cu (of 21.08mi total) to 795 ACSR |
| NYSEG | Westover 115 | Westover | Removal | W | 2024 | 115 | 115 | | N/A | N/A | Remove 115 substation and terminate existing lines to Oakdale 115 (short distance) |
| O & R | Montvale (RECO) | - | Cap Bank | S | 2024 | 69 | 69 | 1 | 32 MVAR | 32 MVAR | Capacitor bank |
| O & R | Ramapo | Sugarloaf | 17.00 | W | 2024 | 138 | 138 | 1 | 1980 | 2120 | 1272 ACSS |
| O & R | Burns | Corporate Drive | 5.00 | W | 2024 | 138 | 138 | 1 | 1980 | 2120 | 1272 ACSS |
| RGE | Station 418 | Station 48 | 7.6 | W | 2024 | 115 | 115 | 1 | 175 MVA | 225 MVA | New 115kV Line |
| RGE | Station 82 | Station 251 (Upgrade Line #902) | | W | 2024 | 115 | 115 | 1 | 400MVA | 400MVA | Line Upgrade |
| RGE | Mortimer | Station 251 (Upgrade Line #901) | 1.00 | W | 2024 | 115 | 115 | 1 | 400MVA | 400MVA | Line Upgrade |
| NGRID | Stoner | Rotterdam | 9.81 | W | 2025 | 115 | 115 | 1 | 1398 | 1708 | Reconductor 9.81mi of 4/0 Cu + 336.4 ACSR (of 23.12mi total) to 1192.5 ACSR |

| Transmission Owner | Terminals | | Line Length in Miles | In-Service Date/Yr | | Nominal Voltage in kV | | # of ckts | Thermal Ratings (4) | | Project Description / Conductor Size |
|--------------------|-----------------|-----------------------|----------------------|---|------|-----------------------|--------|-----------|---------------------|---------|--|
| | | | | Prior to (2) | Year | Operating | Design | | Summer | Winter | |
| | | | | 2020 Gold Book - Firm Plans (5) (included in FERC 715 Base Case) | | | | | | | |
| NGRID | Meco | Rotterdam | 9.81 | W | 2025 | 115 | 115 | 1 | 1398 | 1708 | Reconductor 9.96mi of 4/0 Cu + 336.4 ACSR (of 30.79mi total) to 1192.5 ACSR |
| NGRID | Niagara | Gardenville | 26.3 | S | 2026 | 115 | 115 | 1 | 275MVA | 350MVA | Packard-Erie / Niagara-Gardenville Reconfiguration |
| NGRID | Packard | Gardenville | 28.2 | S | 2026 | 115 | 115 | 2 | 168MVA | 211 MVA | Packard-Gardenville Reactors, Packard-Erie / Niagara-Gardenville Reconfiguration |
| NGRID | Mortimer | Pannell | 15.7 | S | 2026 | 115 | 115 | 2 | 221MVA | 270MVA | |
| NGRID/NYSEG | Erie St | Gardenville | 5.5 | S | 2026 | 115 | 115 | 1 | 139MVA | 179MVA | Packard-Erie / Niagara-Gardenville Reconfiguration, Gardenville add breakers |
| O & R | West Nyack | West Nyack | - | S | 2026 | 138 | 138 | 1 | | | Station Reconfiguration |
| O & R | West Nyack (NY) | Harings Corner (RECO) | 7.00 | W | 2026 | 69 | 138 | 1 | 1604 | 1723 | 795 ACSR |

Appendix C – Resource Adequacy Models and Analysis

Modeling Background

The NYISO conducts its resource adequacy analysis using the GE-MARS software package, which performs probabilistic simulations of outages of capacity and select transmission resources. The program employs a sequential Monte Carlo simulation method and calculates expected values of reliability indices such as LOLE (days/year) and includes load, generation, and transmission representation. Additional modeling details and links to various stakeholders' presentations are in the assumptions matrix, below. In determining the reliability of a system, there are several types of randomly occurring events that are taken into consideration. Among these are the forced outages of generation and transmission, and deviations from the forecasted loads.

Generation Model

The NYISO models the generation system in GE-MARS using several types of units. Thermal units considerations include: random forced outages as determined by Generator Availability Data System (GADS) — calculated EFORD and the Monte Carlo draw, scheduled and unplanned maintenance, and thermal derates. Renewable resource units (*i.e.*, solar PV, wind, run-of-river hydro and landfill gas) are modeled using five years of historical production data. Co-generation units are also modeled using a capacity and load profile for each unit.

Load Model

The load model in the NYISO GE-MARS model consists of historical load shapes and load forecast uncertainty (LFU). The NYISO uses three historical load shapes in the GE-MARS model (2002, 2006 and 2007) in seven different load levels using a normal distribution. LFU is applied to every hour of these historical shapes and each of the seven load levels are run through the GE-MARS model.

External Areas Model

The NYISO models the four external Control Areas interconnected to the NYCA; (ISO-New England, PJM, Ontario and Quebec). The transfer limits between the NYCA and the external areas are set in collaboration with the NPCC CP-8 Working Group and are shown in the MARS Topology Figure 4.6. Additionally, the probabilistic model used in the 2020 RNA to assess resource adequacy employs a number of methods aimed at preventing overreliance on support from the external systems. These include imposing a limit of 3,500 MW to the total emergency assistance from all neighbors, modeling simultaneous peak days, and modeling the long-term purchases and sales with neighboring control areas.

MARS Topology

The NYISO models the amount of power that could be transferred across the system in GE-MARS using interface transfer limits applied to the connections between the GE-MARS areas³³ (“bubble-and-pipe” model).

Impacts of the Post-RNA (CRP) Changes

The impacts of the changes from the final RNA MARS base case to the CRP MARS base case are described below:

- An updated load forecast was modeled in the MARS Base Cases. This change decreased the NYCA LOLE, mainly due to the decrease in the load forecast in Zone J.

Below are the updated end-use energy and peak demand forecasts (along with the resulting final baseline forecasts). There were no updates to any other forecast components.

- The Con Edison series reactors status change impacts on the MARS topology are described below. The impacts are throughout the entire RNA Study Period (2024-2030):
 - Zone G to H (UPNY-~~ConEd~~Con Ed interface) limit decreased by 750 MW (to 6,625 MW)
 - Zone I to J (Dunwoodie South interface, and ~~also~~ its grouping) limit increased by 50 MW (to 4,400 MW)
- Con Edison’s proposed Goethals – Fox Hills 138 kV feeder unbottles Staten Island capacity, and is reflected in the MARS topology as an increase in the corresponding dynamic limits table, as well as below.

Figure 33: Staten Island Dynamic Limits

Final RNA: Staten Island Import Limits, Arthur Kill and Linden CoGen Units

| Unit Availability | | | | J_to_J3 | |
|-------------------|------|---------|---------|---------|-----|
| AK02 | AK03 | LINCOG1 | LINCOG2 | Fwd | Rev |
| A | A | A | A | 315 | 200 |
| U | A | A | A | 315 | 500 |
| A | U | A | A | 315 | 700 |
| A | A | U | A | 315 | 500 |
| A | A | A | U | 315 | 500 |
| Otherwise | | | | 315 | 815 |

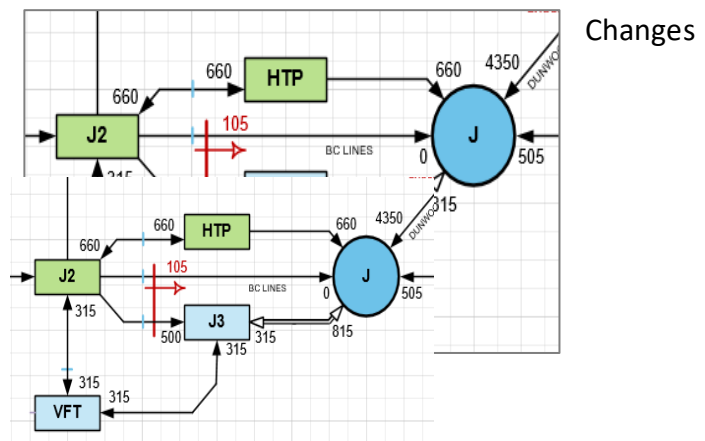

³³ No generation pockets in Zone J and Zone K are modeled in detail in MARS.

CRP updates, 2025 through 2030

Staten Island Import Limits, Arthur Kill and Linden CoGen Units

| | | | | J_to_J3 | |
|-----------|------|---------|---------|---------|-----|
| AK02 | AK03 | LINCOG1 | LINCOG2 | Fwd | Rev |
| A | A | A | A | 315 | 425 |
| U | A | A | A | 315 | 700 |
| A | A | U | A | 315 | 750 |
| A | A | A | U | 315 | 750 |
| Otherwise | | | | 315 | 815 |

The updated CRP MARS topology is below.

CRP MARS Topology Study Years 4-10(2024-2030)

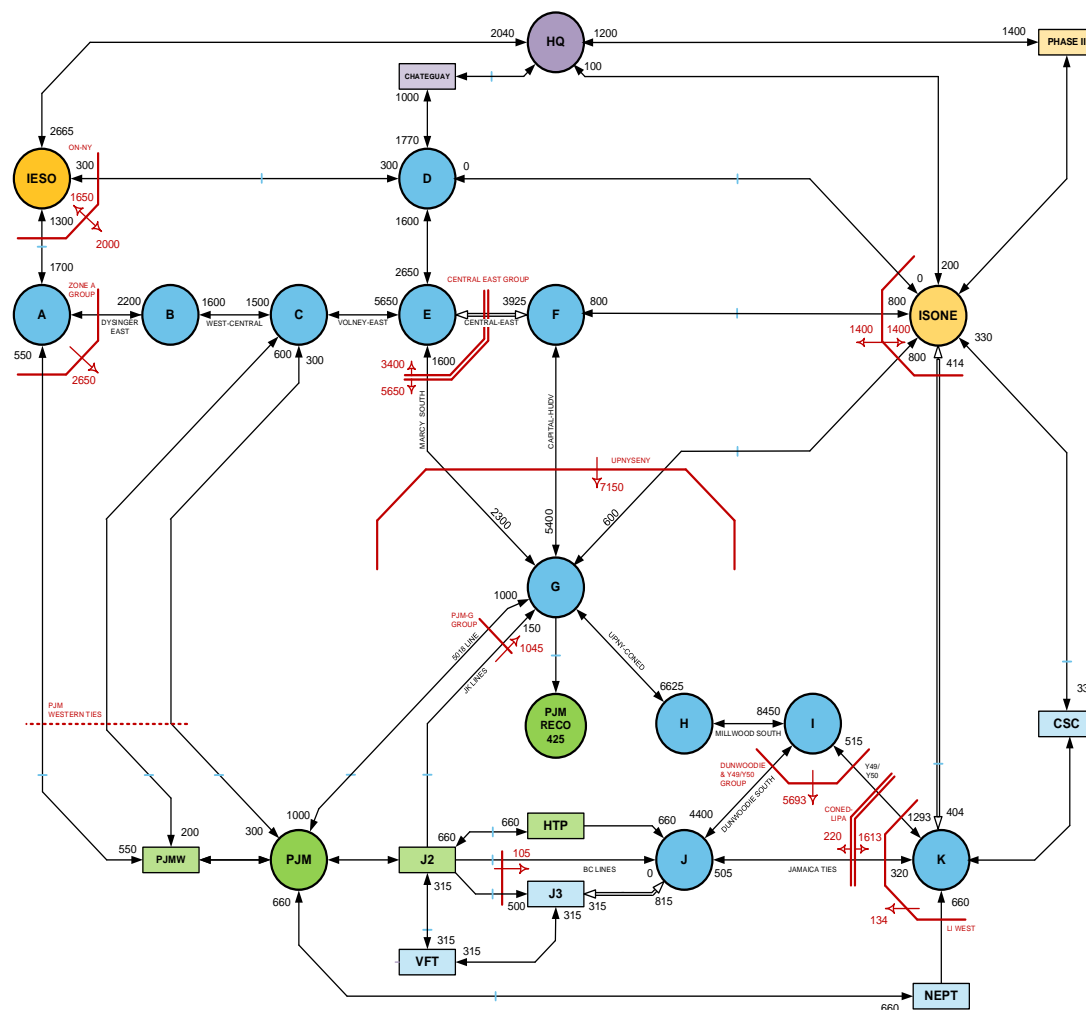

Notes

1. PJM to NY emergency assistance (EA) assumption for calculating the PJM-NY Western ties, PJM-G Group, and ABC Line Group flow distribution limit: 1500MW
2. NYCA EA simultaneous import limit: 3,500 MW
3. External areas representation based upon information received from the NPCC CP-8 WG

Legend

- Interface
- Unidirectional Interface
- Interface w/ Dynamic Ratings
- Interface Group
- Interface Group w/ Dynamic Ratings
- Monitoring Interface Group
- NYCA EA Interface Group Marker
- xx "Dummy Bubble" i.e. no load

NOTE: An interface is considered to not have a MW limitation if no number is specified

**Topology for CRP Base Case with 'Post-2020 RNA' updates: Study Years 2024-2030
Dynamic Limits and Groupings Information**

| Interface Group | Limit | Flow Equation |
|-----------------|-------|----------------------------|
| LI_WEST | 134 | (K to I&J) - 0.13*(K_NEPT) |

Central East Voltage Limits, Oswego Complex Units

| Depends On: | 9MILP1, 9MILP2, FPNUC1, STHIND, OS05, OS06 | | | |
|-----------------|--|------|---------|------|
| Units Available | E_to_F | | E_to_FG | |
| | Fwd | Rev | Fwd | Rev |
| 6 | 3925 | 1999 | 5650 | 3400 |
| 5 | 3875 | 1999 | 5575 | 3400 |
| 4 | 3815 | 1999 | 5490 | 3400 |
| 3 | 3710 | 1999 | 5335 | 3400 |
| 2 | 3595 | 1999 | 5160 | 3400 |
| Otherwise | 3470 | 1999 | 4960 | 3400 |

Staten Island Import Limits, AK and Linden CoGen Units

| Unit Availability | | | | J_to_J3 | |
|-------------------|------|---------|---------|---------|-----|
| AK02 | AK03 | LINCOG1 | LINCOG2 | Fwd | Rev |
| A | A | A | A | 315 | 425 |
| U | A | A | A | 315 | 700 |
| A | A | U | A | 315 | 750 |
| A | A | A | U | 315 | 750 |
| Otherwise | | | | 315 | 815 |

| Depends On: | NPRTS1-4 | |
|-----------------|--------------|--------------|
| Units Available | LI_NE | |
| | Norwalk to K | K to Norwalk |
| 4 | 260 | 414 |
| Otherwise | 404 | 414 |

| Depends On: | Barrett1 and 2 | |
|-----------------|----------------|---------|
| Units Available | ConEd-LIPA | |
| | IJ to K | K to IJ |
| 2 | 1613 | 220 |
| 1 | 1613 | 200 |
| 0 | 1613 | 130 |

| PJM-NY JOA Flow Distribution (Jan 31, 2017 filing) | RECO Load Deliveries | PJM-NY Emergency Assistance |
|--|----------------------|-----------------------------|
| PJM-NY Western Ties | 20% | 46% |
| 5018 Line | 80% | 32% |
| JK Lines | 0% | 15% |
| A Line | 0% | 7% |
| BC Lines | 0% | 0% |

Additionally, MARS topologies for study year 2021 through 2024 are below:

MARS Topology Study Years 4-10 (2021-2024)

Topology for 2020 RNA Base Case: Study Year 2021

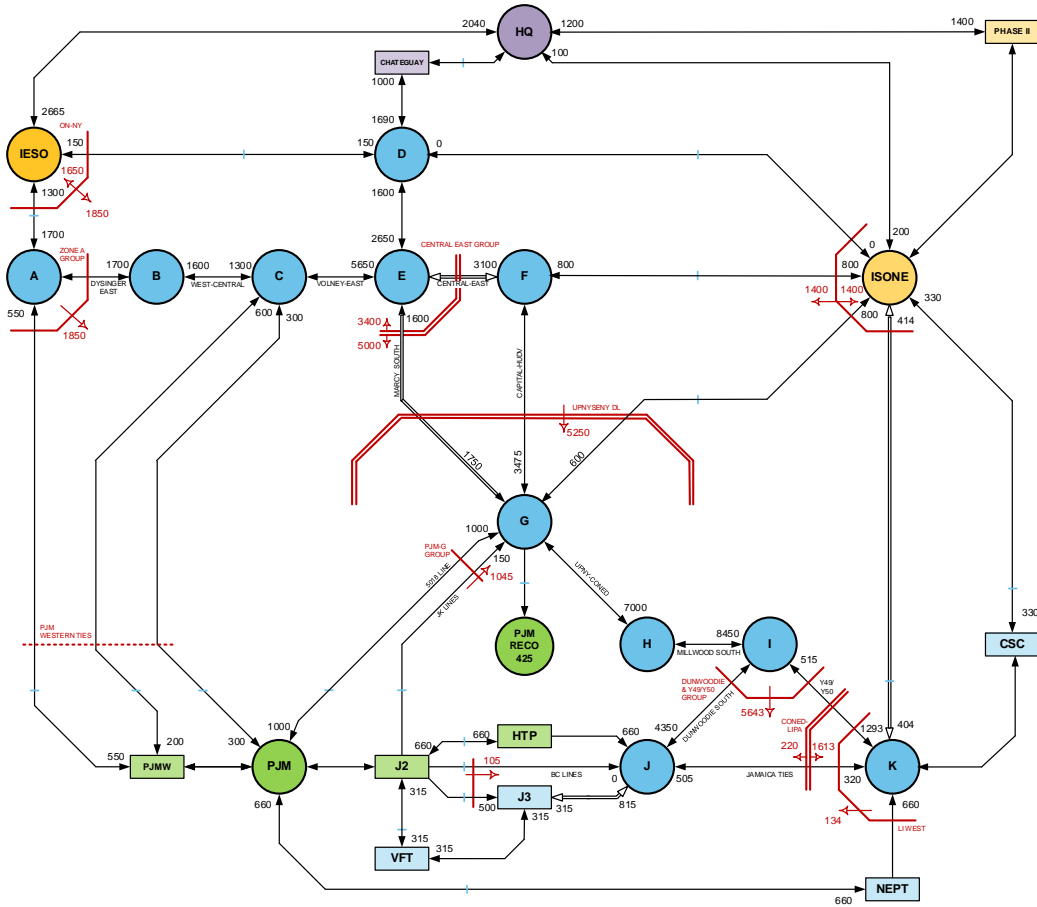

- Notes**
1. PJM to NY emergency assistance (EA) assumption for calculating the PJM-NY Western ties, PJM-G Group, and ABC Line Group flow distribution limit: 1500MW
 2. NYCA EA simultaneous import limit: 3,500 MW
 3. External areas representation based upon information received from the NPCC CP-8 WG

Legend

| | |
|--|------------------------------------|
| | Interface |
| | Unidirectional Interface |
| | Interface w/ Dynamic Ratings |
| | Interface Group |
| | Interface Group w/ Dynamic Ratings |
| | Monitoring Interface Group |
| | NYCA EA Interface Group Marker |
| | "Dummy Bubble" i.e. no load |

NOTE: An interface is considered to not have a MW limitation if no number is specified

Topology for 2020 RNA Base Case: Study Year 2022

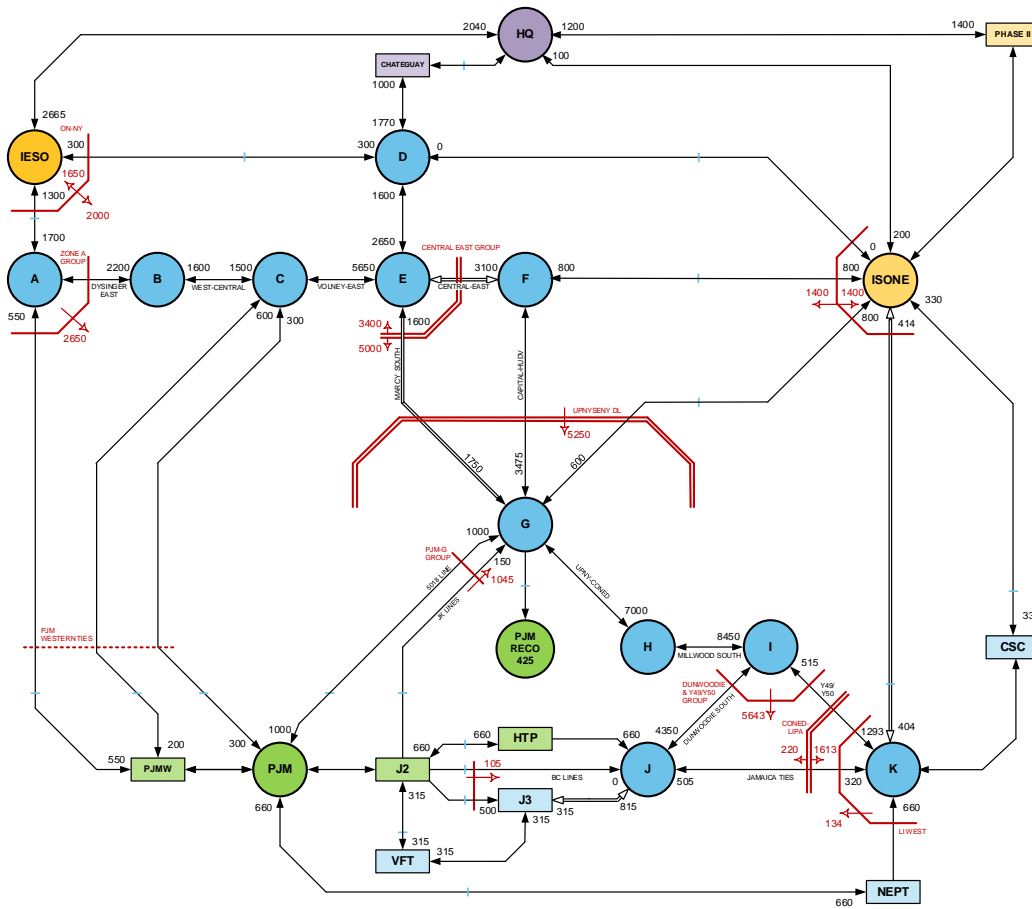

- Notes**
1. PJM to NY emergency assistance (EA) assumption for calculating the PJM-NY Western ties, PJM-G Group, and ABC Line flow distribution limit: 1500MW
 2. NYCA EA simultaneous import limit: 3,500 MW
 3. External areas representation based upon information received from the NPCC CP-8 WG

Legend

| | |
|--|------------------------------------|
| | Interface |
| | Unidirectional Interface |
| | Interface w/ Dynamic Ratings |
| | Interface Group |
| | Interface Group w/ Dynamic Ratings |
| | Monitoring Interface Group |
| | NYCA EA Interface Group Marker |
| | "Dummy Bubble" i.e. no load |

NOTE: An interface is considered to not have a MW limitation if no number is specified

Topology for CRP Base Case with 'Post-2020 RNA' updates: Study Year 2023

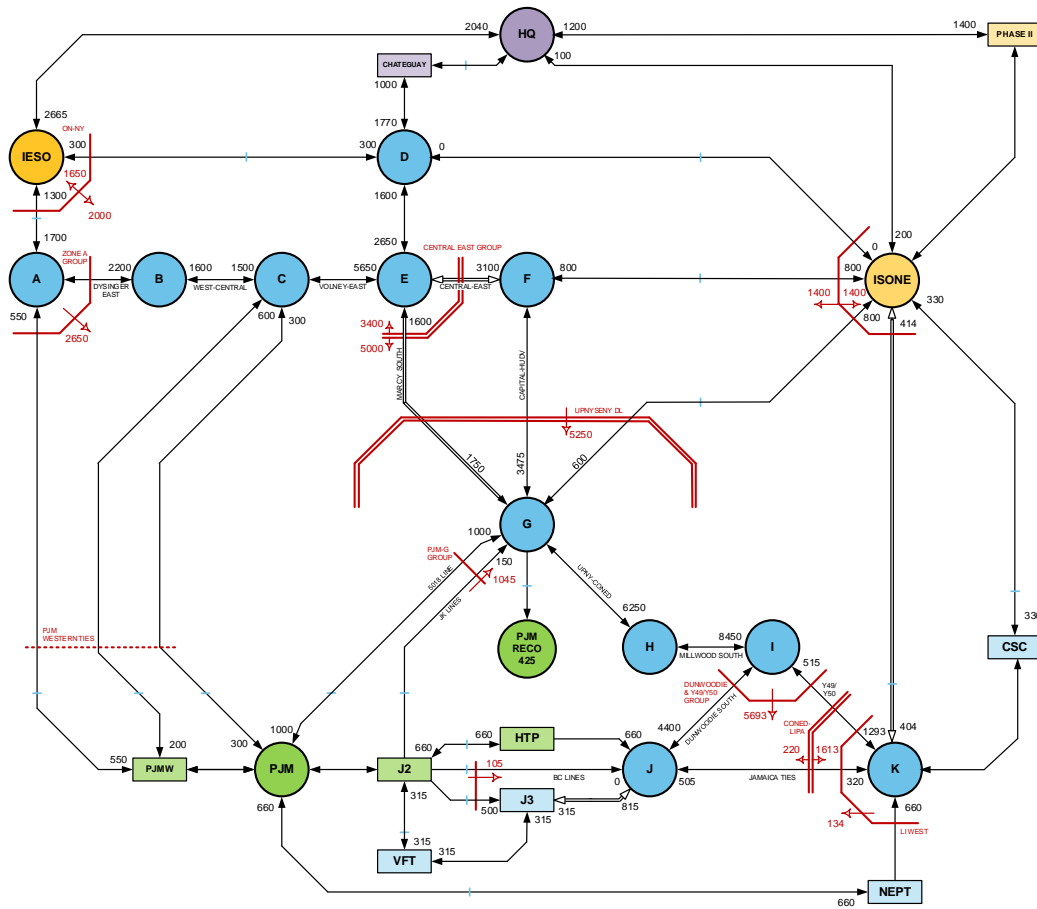

- Notes**
- 1. PJM to NY emergency assistance (EA) assumption for calculating the PJM-NY Western ties, PJM-G Group, and ABC Line Group flow distribution limit: 1500MW
 - 2. NYCA EA simultaneous import limit: 3,500 MW
 - 3. External areas representation based upon information received from the NPCC CP-8 WG

Legend

- ↔ Interface
- Unidirectional Interface
- ⇄ Interface w Dynamic Ratings
- Interface Group
- Interface Group w Dynamic Ratings
- ⋯ Monitoring Interface Group
- ⋯ NYCA EA Interface Group Marker
- xx "Dummy Bubble" i.e. no load

NOTE: An interface is considered to not have a MW limitation if no number is specified

Topology for CRP Base Case with 'Post-2020 RNA' updates: Study Years 2024-2030

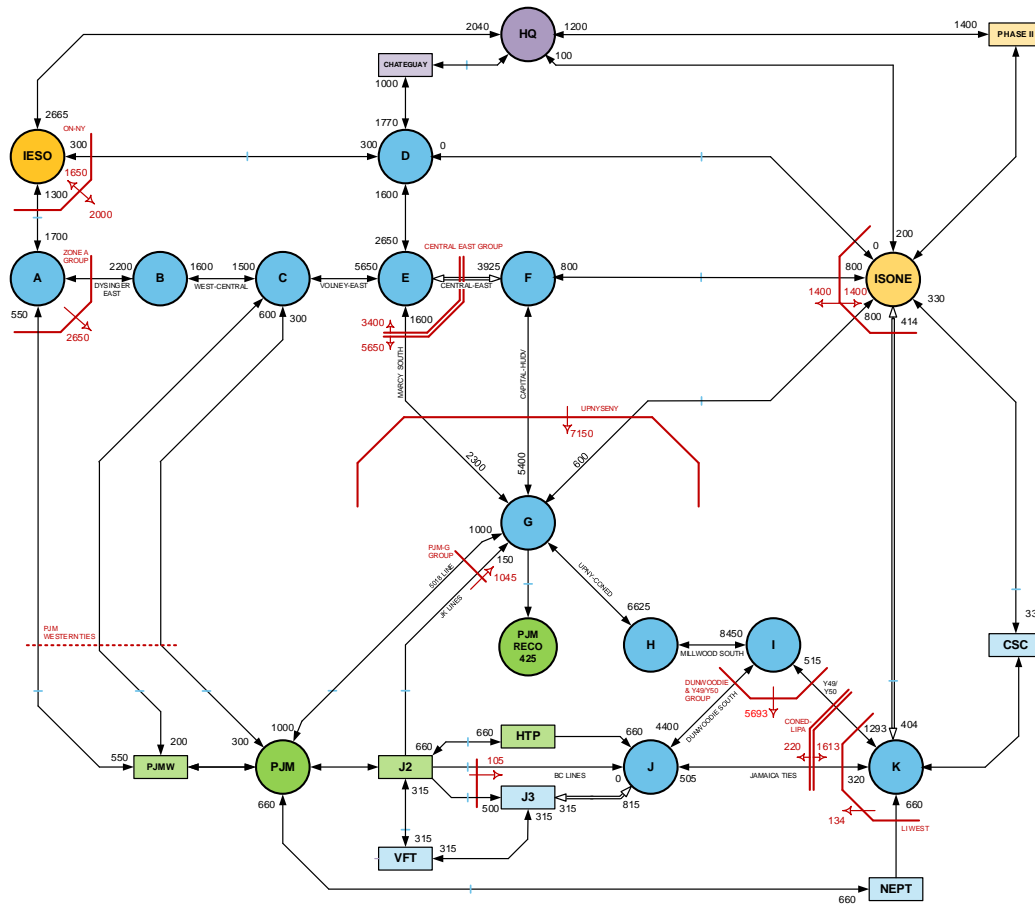

- Notes**
1. PJM to NY emergency assistance (EA) assumption for calculating the PJM-NY Western ties, PJM-G Group, and ABC Line Group flow distribution limit: 1500MW
 2. NYCA EA simultaneous import limit: 3,500 MW
 3. External areas representation based upon information received from the NPCC CP-8 WG

- Legend**
- Interface
 - Unidirectional Interface
 - Interface w/ Dynamic Ratings
 - Interface Group
 - Interface Group w/ Dynamic Ratings
 - Monitoring Interface Group
 - NYCA EA Interface Group Marker
 - "Dummy Bubble" i.e. no load
- NOTE: An interface is considered to not have a MW limitation if no number is specified

Topology for 2020 RNA Base Case: Study Years 2021-2023 Dynamic Limits and Groupings Information

| Interface Group | Limit | Flow Equation |
|-----------------|-------|----------------------------|
| LI_WEST | 134 | (K to I&J) - 0.13*(K_NEPT) |

Central East Voltage Limits, Oswego Complex Units

| Depends On: | 9MILP1, 9MILP2, FPNUC1, STHIND, OS05, OS06 | | | |
|-----------------|--|------|---------|------|
| Units Available | E_to_F | | E_to_FG | |
| | Fwd | Rev | Fwd | Rev |
| 6 | 3100 | 1999 | 5000 | 3400 |
| 5 | 3050 | 1999 | 4925 | 3400 |
| 4 | 2990 | 1999 | 4840 | 3400 |
| 3 | 2885 | 1999 | 4685 | 3400 |
| 2 | 2770 | 1999 | 4510 | 3400 |
| Otherwise | 2645 | 1999 | 4310 | 3400 |

Staten Island Import Limits, AK and Linden CoGen Units

| Unit Availability | | | | J_to_J3 | |
|-------------------|------|---------|---------|---------|-----|
| AK02 | AK03 | LINCOG1 | LINCOG2 | Fwd | Rev |
| A | A | A | A | 315 | 200 |
| U | A | A | A | 315 | 500 |
| A | U | A | A | 315 | 700 |
| A | A | U | A | 315 | 500 |
| A | A | A | U | 315 | 500 |
| Otherwise | | | | 315 | 815 |

| Depends On: | NPRTS1-4 | |
|-----------------|--------------|--------------|
| Units Available | LI_NE | |
| | Norwalk to K | K to Norwalk |
| 4 | 260 | 414 |
| Otherwise | 404 | 414 |

| Depends On: | Barrett1 and 2 | |
|-----------------|----------------|---------|
| Units Available | ConEd-LIPA | |
| | IJ to K | K to IJ |
| 2 | 1613 | 220 |
| 1 | 1613 | 200 |
| 0 | 1613 | 130 |

| PJM-NY JOA Flow Distribution (Jan 31, 2017 filing) | 425MW RECO Load Deliveries | 1500MW PJM-NY Emergency Assistance |
|--|----------------------------|------------------------------------|
| PJM-NY Western Ties | 20% | 46% |
| 5018 Line | 80% | 32% |
| JK Lines | 0% | 15% |
| A Line | 0% | 7% |
| BC Lines | 0% | 0% |

| US DL Limit (MW) | Units Available | | |
|------------------|----------------------|---------|--------|
| | CPV | Cricket | Athens |
| 5250 | 2 | 3 | 3 |
| 5100 | 2 | 3 | 2 |
| 5350 | 1 | 3 | 3 |
| 5200 | 2 | 2 | 3 |
| 5150 | 2 | 1 | 3 |
| 5250 | 1 | 1 | 3 |
| 5100 | 2 | 0 | 3 |
| 5350 | All Other Conditions | | |

| E_TO_G DL Limit (MW) | Units Available CPV |
|----------------------|---------------------|
| 1750 | 2 |
| 2000 | 1 |
| 2250 | 0 |

Draft Topology for 2020 RNA Base Case: Study Years 2024 Dynamic Limits and Groupings Information

| Interface Group | Limit | Flow Equation |
|-----------------|-------|----------------------------|
| LI_WEST | 134 | (K to I&J) - 0.13*(K_NEPT) |

Central East Voltage Limits, Oswego Complex Units

| Depends On: 9MILP1, 9MILP2, FPNUC1, STHIND, OS05, OS06 | | | | |
|--|--------|------|---------|------|
| Units Available | E_to_F | | E_to_FG | |
| | Fwd | Rev | Fwd | Rev |
| 6 | 3925 | 1999 | 5650 | 3400 |
| 5 | 3875 | 1999 | 5575 | 3400 |
| 4 | 3815 | 1999 | 5490 | 3400 |
| 3 | 3710 | 1999 | 5335 | 3400 |
| 2 | 3595 | 1999 | 5160 | 3400 |
| Otherwise | 3470 | 1999 | 4960 | 3400 |

Staten Island Import Limits, AK and Linden CoGen Units

| Unit Availability | | | | J_to_J3 | |
|-------------------|------|---------|---------|---------|-----|
| AK02 | AK03 | LINCOG1 | LINCOG2 | Fwd | Rev |
| A | A | A | A | 315 | 200 |
| U | A | A | A | 315 | 500 |
| A | U | A | A | 315 | 700 |
| A | A | U | A | 315 | 500 |
| A | A | A | U | 315 | 500 |
| Otherwise | | | | 315 | 815 |

| Depends On: NPRTS1-4 | | |
|----------------------|--------------|--------------|
| Units Available | LI_NE | |
| | Norwalk to K | K to Norwalk |
| 4 | 260 | 414 |
| Otherwise | 404 | 414 |

| Depends On: Barrett1 and 2 | | |
|----------------------------|------------|---------|
| Units Available | ConEd-LIPA | |
| | IJ to K | K to IJ |
| 2 | 1613 | 220 |
| 1 | 1613 | 200 |
| 0 | 1613 | 130 |

| PJM-NY JOA Flow Distribution (Jan 31, 2017 filing) | RECO Load Deliveries | PJM-NY Emergency Assistance |
|--|----------------------|-----------------------------|
| PJM-NY Western Ties | 20% | 46% |
| 5018 Line | 80% | 32% |
| JK Lines | 0% | 15% |
| A Line | 0% | 7% |
| BC Lines | 0% | 0% |

CRP Base Case Event Analysis

Loss of Load Expectation (LOLE, in days/year) is generally defined as the expected (weighted average) number of days in a given time period (*e.g.*, one study year) when at least one hour from that day, the hourly demand (for each of the seven load bins and per replication) is projected to exceed the zonal resources capacity (event day) in any of the seven load bins. Within a day, if the zonal demand exceeds the resources in at least one hour of that day (could be anywhere from hour 1 to 24, consecutive or not), this will be counted as **one event day** for the respective load bin and replication. The NYISO currently simulates 2,000 replications per study year and load level (seven load bins), for a total of 14,000 replications per study year. Weighted average is based on load bin probability, total bin event days, and total number of replications. NYSRC and NPCC's LOLE criterion is that the NYCA LOLE not exceed one day in 10 years, or LOLE < 0.1 days/year.

For each study year and in a single MARS replication, the zonal MW hourly margins (MW surplus or deficit) are calculated for each bin using load forecast uncertainty (LFU) applied load, forced outage calculations, hourly shape values (*i.e.*, wind, solar, run-of-river hydro, landfill gas), contracts and interface

flows. In instances where there is a deficit in any area, emergency operating procedures (EOPs) steps are completed until either the deficits are gone, or there are no more EOP steps to call. Once all of this is completed MARS calculates the reliability indices (LOLE, LOLH, LOEE) for the replication. This occurs concurrently across all load levels simultaneously: MARS lumps them all together in a weighted sum to get a single value for each replication.

$$\text{NYCA LOLE (days/year)} = \frac{1}{N} \sum_{i=1}^7 D_i P_i$$

$$\text{NYCA LOLH (hour/year)} = \frac{1}{N} \sum_{i=1}^7 H_i P_i$$

$$\text{NYCA EUE (MWh)} = \frac{1}{N} \sum_{i=1}^7 E_i P_i$$

where, D_i is the **event days** for bin i for the study year

H_i is the **event hours** for bin i

E_i is the MW deficit for bin i

P_i is the **probability of occurring of bin i** which is the LFU probability data

N is the total number of **replications** e.g. 2000

The below figures provide additional insight into how the LOLE bin and month distribution for the CRP Base Case, study year 2030. Additional details on load forecast uncertainty (LFU) and MARS load bins is under the April 13, 2020 Load Forecast Task Force presentation [\[link\]](#)

Key observation: ~~the~~

- The MARS events for the CRP Base Case study year 2030 are distributed in June, July, and August, in the afternoon hours, and in load bins 1 and 2.

Figure 34: CRP Base Case, Study Year 2030, Bin and Month LOLE Distributions

| | | LOLE (dy/yr) | | | | | | | |
|--------|--|--------------|--------|--------|--------|---|---|---|--------|
| | | 1 | 2 | 3 | 4 | 5 | 6 | 7 | Total |
| Jan | | | | | | | | | |
| Feb | | | | | | | | | |
| Mar | | | | | | | | | |
| Apr | | | | | | | | | |
| May | | | | | | | | | |
| Jun | | 0.0000 | 0.0002 | 0.0002 | 0.0002 | | | | 0.0006 |
| Jul | | 0.0138 | 0.0145 | 0.0002 | | | | | 0.0286 |
| Aug | | 0.0036 | 0.0289 | 0.0024 | 0.0002 | | | | 0.0351 |
| Sep | | | | | | | | | |
| Oct | | | | | | | | | |
| Nov | | 0.0000 | | | | | | | 0.0000 |
| Dec | | | | | | | | | |
| Annual | | 0.0174 | 0.0437 | 0.0029 | 0.0004 | | | | 0.0644 |
| | | 1 | 2 | 3 | 4 | 5 | 6 | 7 | Total |

Figure 35: CRP Base Case, Study Year 2030, Event Summary

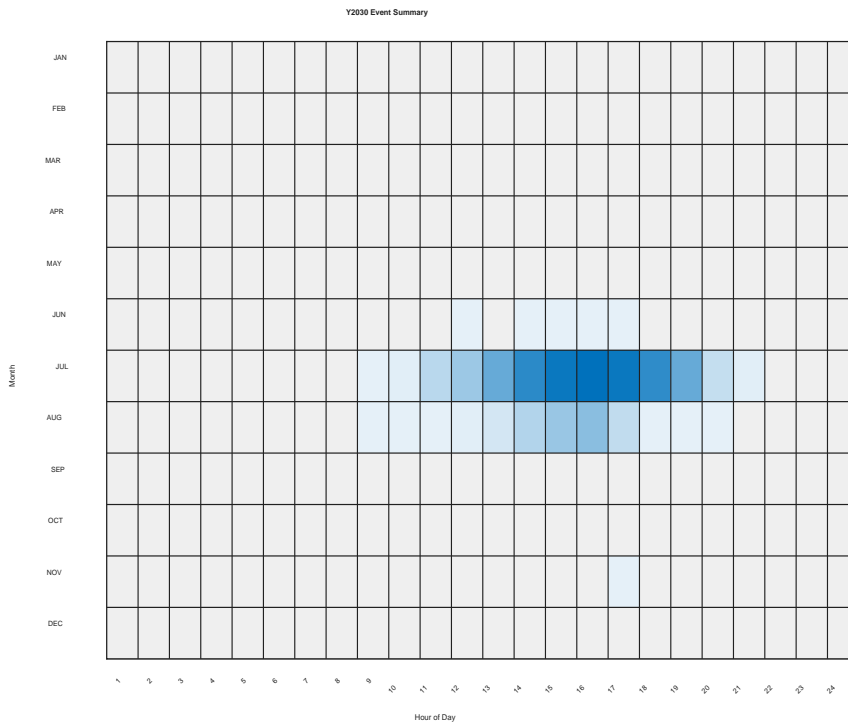
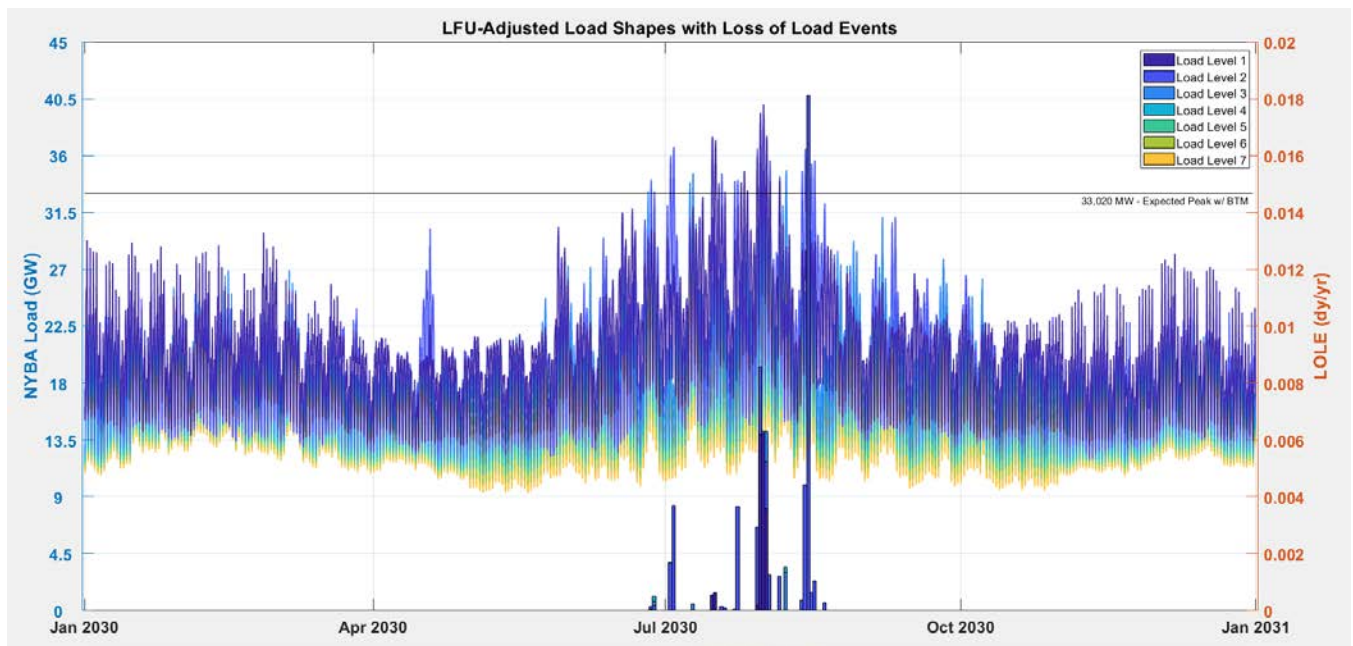

Figure 36: CRP Base Case, Study Year 2030, LFU-Adjusted Load Shapes vs Load Events



Resource Adequacy Assumptions Matrix

| # | Parameter | 2018 RNA/CRP (2018 GB) Study Period: 2019 -2028 | 2020 RNA (2020 GB) Study Period: 2024(y4) -2030 (y10) | 2021 CRP 2020 GB with <u>updates</u> : Study Period: 2024(y4) -2030 (y10) |
|------------------------------|--|--|---|---|
| Load Parameters | | | | |
| 1 | Peak Load Forecast | Adjusted 2018 Gold Book NYCA baseline peak load forecast. The GB 2018 baseline peak load forecast includes the impact (reduction) of behind-the-meter (B&T M) solar at the time of NYCA peak. For the Resource Adequacy load model, the deducted B&T M solar MW was added back to the NYCA zonal loads, which then allows for a discrete modeling of the B&T M solar resources. | Similar method | Similar method Updated long term energy and peak forecasts: Nov 19, 2020 ESPWG/LFTF/TPAS/ICAP <u>presentation</u> |
| 2 | Load Shapes (Multiple Load Shapes) | Used Multiple Load Shape MARS Feature 8,760 hour historical load shapes were used as base shapes for LFU bins: Bin 1: 2006 Bin 2: 2002 Bins 3-7: 2007 Peak adjustments on a seasonal basis. For the B&T M Solar adjustment, the B&T M shape is added back to account for the impact of the B&T M generation on both on-peak and off-peak hours. | Similar method | No change from 2020 RNA |
| 3 | Load Forecast Uncertainty (LFU) | Used updated summer LFU values for the 11 NYCA zones. | Updated via Load Forecast Task Force (LFTF) process Reference: April 13 2020 LFTF presentation: https://www.nyiso.com/documents/20142/11883362/LFU_Summary.pdf | No change from 2020 RNA |
| Generation Parameters | | | | |
| 1 | Existing Generating Unit Capacities | 2018 Gold Book values. Use summer min (DMNC vs. CRIS). Use winter min (DMNC vs. CRIS). Adjusted for RNA inclusion rules. | Similar method | No change from 2020 RNA |

| | | | | |
|---|---|--|----------------|-------------------------|
| 2 | Proposed New Units Inclusion Determination | GB2018 with Inclusion Rules Applied | Similar method | No change from 2020 RNA |
| 3 | Retirement, Mothballed Units, IIFO | GB2018 with Inclusion Rules Applied | Similar method | No change from 2020 RNA |
| 4 | Forced and Partial Outage Rates | <p>Five-year (2013-2017) GADS data for each unit represented. Those units with less than five years – use representative data.</p> <p>Transition Rates representing the Equivalent Forced Outage Rates (EFORd) during demand periods over the most recent five-year period</p> <p>For new units or units that are in service for less than three years, NERC 5-year class average EFORd data are used.</p> | Similar method | No change from 2020 RNA |
| 5 | Planned Outages | Based on schedules received by the NYISO and adjusted for history | Similar method | No change from 2020 RNA |
| 6 | Summer Maintenance | Nominal 50 MW (25 in J and 25 in K) | None | No change from 2020 RNA |
| 7 | Combustion Turbine Derates | <p>Derate based on temperature correction curves</p> <p>For new units: used data for a unit of same type in same zone, or neighboring zone data.</p> | Similar method | No change from 2020 RNA |
| 8 | Existing Landfill Gas Plants | <p>New method: Actual hourly plant output over the period 2013-2017. Program randomly selects a LFG shape of hourly production over the 2013-2017 for each model replication.</p> <p>Probabilistic model is incorporated based on five years of input shapes, with one shape per replication randomly selected in the Monte Carlo process.</p> | Similar method | No change from 2020 RNA |
| 9 | Existing Wind Units (>5 years of data) | <p>Actual hourly plant output over the period 2013-2017.</p> <p>Probabilistic model is incorporated based on five years of input shapes with one shape per replication being randomly selected in Monte Carlo process</p> | Similar method | No change from 2020 RNA |

| | | | | |
|-----|---|---|--|-------------------------|
| 10 | Existing Wind Units (<5 years of data) | For existing data, the actual hourly plant output over the period 2013-2017 is used. For missing data, the nameplate normalized average of units in the same load zone is scaled by the unit's nameplate rating. | Similar method | No change from 2020 RNA |
| 11a | Proposed Land based Wind Units | Inclusion Rules Applied to determine the generator status. The nameplate normalized average of units in the same load zone is scaled by the unit's nameplate rating. | Similar method | No change from 2020 RNA |
| 11b | Proposed Offshore Wind Units | N/A | N/A | N/A |
| 12a | Existing Utility-scale Solar Resources | The 31.5 MW Upton metered solar capacity: probabilistic model chooses from 5 years of production data output shapes covering the period 2013-2017 (one shape per replication is randomly selected in Monte Carlo process.) | Similar method | No change from 2020 RNA |
| 12b | Proposed Utility-scale Solar Resources | Inclusion Rules Applied to determine the generator status. The nameplate normalized average of units in the same load zone is scaled by the unit's nameplate rating. | Similar method | No change from 2020 RNA |
| 13 | Projected B&T Solar Resources | The large projection of increasing retail (B&T) solar installations over the 10- year period require a discrete model with detailed hourly performance. New method: An 8,760 hourly shape was created by using NREL's PV Watt ³⁴ tool. MARS will randomly select a daily shape from the current month for each day of each month of each replication. | New Method: Will use 5-year of inverter production data. Probabilistic model is incorporated based on five years of input shapes with one shape per replication being randomly selected in Monte Carlo process Reference: April 6, 2020 TPAS/ESPGWG meeting materials | No change from 2020 RNA |

³⁴ NREL's PVWatts Calculator, credit of the U.S. Department of Energy (DOE)/NREL/Alliance (Alliance for Sustainable Energy, LLC).

| | | | | |
|--|---------------------------------------|---|----------------|-------------------------|
| 14 | Existing BTM-NG Program | New category: These are former load modifiers to sell capacity into the ICAP market. Modeled as cogen type 2 unit in MARS. Unit capacity set to CRIS value, load modeled with weekly pattern that can change monthly. | Similar method | No change from 2020 RNA |
| 15 | Existing Small Hydro Resources | New method: Actual hourly plant output over the period 2013-2017. Program randomly selects a hydro shape of hourly production over the 5-year window for each model replication. The randomly selected shape is multiplied by their current nameplate rating. | Similar method | No change from 2020 RNA |
| 16 | Existing Large Hydro | Probabilistic Model based on 5 years of GADS data. Transition Rates representing the Equivalent Forced Outage Rates (EFORd) during demand periods over the most recent five-year period (2013-2017). Methodology consistent with thermal unit transition rates. | Similar method | No change from 2020 RNA |
| 17 | Proposed Energy Storage | N/A | N/A | N/A |
| Transaction - Imports / Exports | | | | |
| 1 | Capacity Purchases | Grandfathered Rights and other awarded long-term rights Modeled using MARS explicit contracts feature. | Similar method | No change from 2020 RNA |
| 2 | Capacity Sales | These are long-term contracts filed with FERC. Modeled using MARS explicit contracts feature. Contracts sold from ROS (Zones: A-F). ROS ties to external pool are derated by sales MW amount | Similar method | No change from 2020 RNA |

| | | | | |
|--|------------------------|---|--|--|
| 3 | FCM Sales | Model sales for known years Modeled using MARS explicit contracts feature. Contracts sold from ROS (Zones: A-F). ROS ties to external pool are derated by sales MW amount | Similar method | No change from 2020 RNA |
| 4 | UDRs | Updated with most recent elections/awards information (VFT, HTP, Neptune, CSC) | Similar method | No change from 2020 RNA |
| 5 | EDRs | N/A | <p>New category: Cedars Uprate 80 MW. Increased the HQ to D by 80 MW.</p> <p>Note: the Cedar bubble has been removed and its corresponding MW was reflected in HQ to D limit.</p> <p>References:</p> <ol style="list-style-type: none"> March 16, 2020 ESPWG/TPAS April 6, 2020 TPAS/ESPWG | No change from 2020 RNA |
| 6 | Wheel-Through Contract | n/a | <p>New category: 300 MW HQ through NYISO to ISO-NE. Modeled as firm contract. Reduced the transfer limit from HQ to NYISO by 300 MW and increased the transfer limit from NYISO to ISO-NE by 300 MW.</p> | No change from 2020 RNA |
| MARS Topology: a simplified bubble-and-pipe representation of the transmission system | | | | |
| 0 | | | <p>Summary of major topology changes (as compared with the 2018-2019 RPP): Link1)-7); Link8)-9); Link10)</p> <ol style="list-style-type: none"> 1) Marion-Farragut 345kV cables (B and C) assumed out of service 2) 71, 72, M51, M52 series reactors assumed by-passed after deactivation of Indian Point 3) Moses – St. Lawrence (L33P) tie line assumed out of service | <p>Summary of major topology changes as compared with the 2020 RNA [link]:</p> <ol style="list-style-type: none"> 1. The ConEd series reactors status change impacts, throughout the entire RNA Study Period (2024-2030): <ul style="list-style-type: none"> • G to H (UPNY-ConEd interface) limit decrease by 750 MW (to 6625 MW) • I to J (Dunwoodie South interface) group limit increase |

| | | | | |
|---------------------------------------|------------------------------|--|--|---|
| | | | <ul style="list-style-type: none"> 4) Rainey – Corona transmission project in service impacting J to K limits 5) UPNY-SENY simplification 2021-2023 before the addition of AC PPTPP projects 6) AC PPTPs Segment A and B Projects Added starting 2024 7) Removal of Cedars bubble/tie to Zone D model; adding the MW from the bubble to the tie HQ to D tie limit. 8) Removal of PJM-SENY Group Interface 9) Updates to Zone K Imports/Exports 10) Somerset retirement impacts 11) The external areas model for PJM and ISO-NE were simplified by consolidating the 5 PJM areas (bubbles) into one, and the 8 ISO-NE areas into one. | <p>by 50 MW (to 4400 MW)</p> <p>2. The ConEd LTPs unbottles Staten Island capacity, reflected in the MARS topology as increase in the corresponding dynamic limit table</p> |
| 1 | Interface Limits | Developed by review of previous studies and specific analysis during the RNA study process | Similar method | No change from 2020 RNA |
| 2 | New Transmission | Based on TO- provided firm plans (via Gold Book 2018 process) and proposed merchant transmission; inclusion rules applied | Similar method | No change from 2020 RNA |
| 3 | AC Cable Forced Outage Rates | All existing cable transition rates updated with data received from ConEd and PSEG-LIPA to reflect most recent five-year history | Similar method | No change from 2020 RNA |
| 4 | UDR unavailability | Five-year history of forced outages | Similar method | No change from 2020 RNA |
| Emergency Operating Procedures | | | | |
| 1 | Special Case Resources | SCRs sold for the program discounted to historic availability (“effective capacity”). Summer values calculated from the latest available July registrations, held constant for all years of study. 5 calls/month | <p>Similar method but with 15 calls/year</p> <p>Note: also, combined the two SCR steps (generation and load zonal MW)</p> | No change from 2020 RNA |

| | | | | |
|-------------------------------|---------------------------------|--|--|--|
| 2 | EDRP Resources | 2018 Gold Book with effective capacity modeled. Resources sold for the program and discounted to historic availability. Summer values calculated from July 2018 registrations and forecast growth. Values held constant for all years of study. | Not modeled: the values are less than 2 MW. | No change from 2020 RNA |
| 3 | Other EOPs | Based on TO information, measured data, and NYISO forecasts | Similar method | No change from 2020 RNA |
| External Control Areas | | | | |
| 1 | PJM | As per RNA Procedure External model (load, capacity, topology) provided by PJM/NPCC CP-8 WG. PJM is a 5-zone model. LOLE of pool adjusted to be between 0.10 and 0.15 days per year by adjusting capacity pro-rata in all areas. | New model: Simplified model: The 5 PJM MARS areas (bubbles) were consolidated into one | No change from 2020 RNA |
| 2 | ISONE | As per RNA Procedure External model (load, capacity, topology) provided by PJM/NPCC CP-8 WG. LOLE of pool adjusted to be between 0.10 and 0.15 days per year by adjusting capacity pro-rata in all areas. | New model: Simplified model: The 8 ISONE MARS areas (bubbles) were consolidated into one | No change from 2020 RNA |
| 3 | HQ | As per RNA Procedure External model (load, capacity, topology) provided by PJM/NPCC CP-8 WG. LOLE of pool adjusted to be between 0.10 and 0.15 days per year by adjusting capacity pro-rata in all areas. | Similar method | No change from 2020 RNA |
| 4 | IESO | As per RNA Procedure External model (load, capacity, topology) provided by PJM/NPCC CP-8 WG. LOLE of pool adjusted to be between 0.10 and 0.15 days per year by adjusting capacity pro-rata in all areas. | Similar method | No change from 2020 RNA |
| 5 | Reserve Sharing | All NPCC Control Areas indicate that they will share reserves equally among all members before sharing with PJM. | Similar method | No change from 2020 RNA |
| 6 | NYCA Emergency Assistance Limit | Implemented a statewide limit of 3,500 MW | Similar method | No change from 2020 RNA |
| Miscellaneous | | | | |
| 1 | MARS Model Version | Version 3.22.6 | 3.29.1499 | 3.29.1499 (also run on new MARS rev with no significant change in results) |

Appendix D – Transmission Security Margins (“Tipping Points”)

The purpose of this assessment is to identify plausible changes in conditions or assumptions that might adversely impact the reliability of the Bulk Power Transmission Facilities (“BPTF”) or “tip” the system into violation of a transmission security criterion. This assessment is performed using a deterministic approach through a spreadsheet-based methods based on input from the 2021 Load and Capacity Data Report (“Gold Book”) and CRP base case updates. For this assessment, “tipping points” are evaluated for the NYCA as well as the Zone G-J, J, and K localities. For this evaluation the system tips when the transmission security margin is less than 0 or when a condition could change that is larger than the security margin.

New York Control Area (NYCA) Tipping Points

The tipping points for the NYCA are evaluated under summer peak conditions. A tipping point occurs when the transmission security margin is a negative value. The transmission security margin is the ability to meet load plus losses and system reserve (*i.e.*, total capacity requirement) against the NYCA generation, interchanges, and temperature-based generation de-rates (“total resources”). The NYCA generation (from line-item A) is comprised of the existing generation plus additions of future generation resources that meet the reliability planning process base case inclusion rules as well as the removals of deactivating generation and peaker units. Consistent with transmission planning practices for transmission security, (i) wind generation is assumed at a 0 MW output, (ii) run-of-river hydro is reduced consistent with its average capacity factor, and (iii) is solar dispatched based on the ratio of its nameplate capacity and solar PV peak reductions stated in the 2021 Gold Book. Additionally, the NYCA generation includes the Oswego export limit for all lines in-service. **Figure 37** provides a summary of the NYCA transmission security margin.

As shown in **Figure 37**, under baseline load conditions the transmission security margin (line-item H) ranges between 2,303 MW in 2022 to 1,318 MW in 2031. The annual fluctuations are driven by the decreases in NYCA generation (line-item A) and in the load forecast (line-item E). In consideration of the transmission security margin (line-item H), the values show that it is feasible to not tip into the largest source of 1,310 MW (loss of Nine Mile Unit 2).³⁵ However, in 2031 this combination of conditions results in a transmission security margin of 8 MW.³⁶

³⁵ <https://www.nyiso.com/documents/20142/3691300/Summer-2020-Operating-Study-Draft-Final-OC-Approved.pdf/>

³⁶ This value is calculated as 1,318 MW – 1,310 MW = 8 MW.

It is feasible for other combinations of events to tip the system over its margin, such as increased load or a combination of reductions in total resources and load. An additional evaluation shown in **Figure 37** is the impact of the historical forced outage rate of NYCA thermal generation on the transmission security margin. Also, while SCRs are not included for transmission security analysis under normal conditions, they are used for this forced outage rate evaluation. The adjusted transmission security margin (line_item K) shows that sufficient margin exists under this condition.

Figure 37: NYCA Summer Transmission Security Margin (NYCA Summer Baseline Peak Forecast - Normal)

| Line | Item | Peak Load Forecast | | | | | | | | | |
|------|--|--------------------|----------|----------|----------|----------|----------|----------|----------|----------|----------|
| | | 2022 | 2023 | 2024 | 2025 | 2026 | 2027 | 2028 | 2029 | 2030 | 2031 |
| A | NYCA Generation (1) | 35,257 | 34,307 | 34,297 | 33,684 | 33,679 | 33,679 | 33,674 | 33,669 | 33,664 | 33,659 |
| B | External Area Interchanges (2) | 1,844 | 1,844 | 1,844 | 1,844 | 1,844 | 1,844 | 1,844 | 1,844 | 1,844 | 1,844 |
| C | Temperature Based Generation Derates | 0 | 0 | 0 | 0 | 0 | 0 | 0 | 0 | 0 | 0 |
| D | Total Resources (A+B+C) | 37,101 | 36,151 | 36,141 | 35,528 | 35,523 | 35,523 | 35,518 | 35,513 | 35,508 | 35,503 |
| E | Load Forecast | (32,178) | (31,910) | (31,641) | (31,470) | (31,326) | (31,278) | (31,284) | (31,348) | (31,453) | (31,565) |
| F | Operating Reserve Requirement | (2,620) | (2,620) | (2,620) | (2,620) | (2,620) | (2,620) | (2,620) | (2,620) | (2,620) | (2,620) |
| G | Total Capability Requirement (E+F) | (34,798) | (34,530) | (34,261) | (34,090) | (33,946) | (33,898) | (33,904) | (33,968) | (34,073) | (34,185) |
| H | Transmission Security Margin (D+G) | 2,303 | 1,621 | 1,880 | 1,438 | 1,577 | 1,625 | 1,614 | 1,545 | 1,435 | 1,318 |
| I | SCRs (4), (5) | 822 | 822 | 822 | 822 | 822 | 822 | 822 | 822 | 822 | 822 |
| J | Forced Outages (3) | (2,164) | (1,952) | (1,952) | (1,867) | (1,867) | (1,867) | (1,867) | (1,867) | (1,867) | (1,867) |
| K | Adjusted Transmission Security Margin (H+I+J) (4) | 961 | 491 | 750 | 393 | 532 | 580 | 569 | 500 | 390 | 273 |

Notes:

1. Reflects the 2021 Gold Book existing summer capacity plus projected additions, deactivations, and de-rates. For this evaluation wind generation is assumed to have 0 MW output, solar generation is based on the ratio of solar PV nameplate capacity (2021 Gold Book Table I-9a) and solar PV peak reductions (2021 Gold Book Table I-9c). De-rates for run-of-river hydro is included as well as the Oswego Export limit for all lines in-service.
2. Interchanges are based on ERAG MMWG values.
3. Includes de-rates for thermal resources.
4. Special Case Resources (SCRs) are not applied for transmission security analysis of normal operations.
5. Includes a de-rate of 373 MW for SCRs.

Figure 38 shows the transmission security margin for the 1-in-10 year load conditions (also known as 90/10 or 90th percentile load) under the assumption that the system is in an emergency condition. Although the system is not designed under Transmission Security for the 90th percentile forecast, **Figure 38** shows the margin that would exist (Line_item I). As shown in **Figure 38**, under the 90th percentile load conditions the inclusion of additional, the historical forced outage rate of thermal unit forced outages generation (line_item J) shows that the system tips in 2022 (line_item K) and remains below the transmission security margin through 2031.

Figure 38: NYCA Summer Transmission Security Margin (NYCA 1-in-10 (90/10) Peak Forecast - Emergency)

| Line | Item | 90th Percentile Forecast | | | | | | | | | |
|------|--|--------------------------|-----------------|-----------------|-----------------|-----------------|-----------------|-----------------|-----------------|-----------------|-----------------|
| | | 2022 | 2023 | 2024 | 2025 | 2026 | 2027 | 2028 | 2029 | 2030 | 2031 |
| A | NYCA Generation (1) | 35,257 | 34,307 | 34,297 | 33,684 | 33,679 | 33,679 | 33,674 | 33,669 | 33,664 | 33,659 |
| B | External Area Interchanges (2) | 1,844 | 1,844 | 1,844 | 1,844 | 1,844 | 1,844 | 1,844 | 1,844 | 1,844 | 1,844 |
| C | SCRs (4), (5) | 822 | 822 | 822 | 822 | 822 | 822 | 822 | 822 | 822 | 822 |
| D | Temperature Based Generation Derates | (208) | (195) | (195) | (185) | (185) | (185) | (185) | (185) | (185) | (185) |
| E | Total Resources (A+B+C+D) | 37,715 | 36,778 | 36,768 | 36,164 | 36,159 | 36,159 | 36,154 | 36,149 | 36,144 | 36,139 |
| F | Load Forecast | (34,158) | (33,871) | (33,582) | (33,399) | (33,246) | (33,191) | (33,195) | (33,262) | (33,373) | (33,490) |
| G | Operating Reserve Requirement | (2,620) | (2,620) | (2,620) | (2,620) | (2,620) | (2,620) | (2,620) | (2,620) | (2,620) | (2,620) |
| H | Total Capability Requirement (F+G) | (36,778) | (36,491) | (36,202) | (36,019) | (35,866) | (35,811) | (35,815) | (35,882) | (35,993) | (36,110) |
| I | Transmission Security Margin (E+H) | 937 | 287 | 566 | 145 | 293 | 348 | 339 | 267 | 151 | 29 |
| J | Forced Outages (3) | (2,164) | (1,952) | (1,952) | (1,867) | (1,867) | (1,867) | (1,867) | (1,867) | (1,867) | (1,867) |
| K | Adjusted Transmission Security Margin (I+J) | (1,227) | (1,665) | (1,386) | (1,722) | (1,574) | (1,519) | (1,528) | (1,600) | (1,716) | (1,838) |

Notes:

1. Reflects the 2021 Gold Book existing summer capacity plus projected additions, deactivations, and de-rates. For this evaluation wind generation is assumed to have 0 MW output, solar generation is based on the ratio of solar PV nameplate capacity (2021 Gold Book Table I-9a) and solar PV peak reductions (2021 Gold Book Table I-9c). De-rates for run-of-river hydro is included as well as the Oswego Export limit for all lines in-service.
2. Interchanges are based on ERAG MMWG values.
3. Includes de-rates for thermal resources.
4. SCRs are not applied for transmission security analysis of normal operations, but are included for emergency operations.
5. Includes a de-rate of 373 MW for SCRs.

| Line | Item | 90th Percentile Forecast | | | | | | | | | |
|------|--|--------------------------|-----------------|-----------------|-----------------|-----------------|-----------------|-----------------|-----------------|-----------------|-----------------|
| | | 2022 | 2023 | 2024 | 2025 | 2026 | 2027 | 2028 | 2029 | 2030 | 2031 |
| A | NYCA Generation (1) | 35,257 | 34,307 | 34,297 | 33,684 | 33,679 | 33,679 | 33,674 | 33,669 | 33,664 | 33,659 |
| B | External Area Interchanges (2) | 1,844 | 1,844 | 1,844 | 1,844 | 1,844 | 1,844 | 1,844 | 1,844 | 1,844 | 1,844 |
| C | SCRs (4), (5) | 822 | 822 | 822 | 822 | 822 | 822 | 822 | 822 | 822 | 822 |
| D | Temperature Based Generation Derates | (208) | (195) | (195) | (185) | (185) | (185) | (185) | (185) | (185) | (185) |
| E | Total Resources (A+B+C+D) | 37,715 | 36,778 | 36,768 | 36,164 | 36,159 | 36,159 | 36,154 | 36,149 | 36,144 | 36,139 |
| F | Load Forecast | (34,158) | (33,871) | (33,582) | (33,399) | (33,246) | (33,191) | (33,195) | (33,262) | (33,373) | (33,490) |
| G | Operating Reserve Requirement | (2,620) | (2,620) | (2,620) | (2,620) | (2,620) | (2,620) | (2,620) | (2,620) | (2,620) | (2,620) |
| H | Total Capability Requirement (F+G) | (36,778) | (36,491) | (36,202) | (36,019) | (35,866) | (35,811) | (35,815) | (35,882) | (35,993) | (36,110) |
| I | Transmission Security Margin (E+H) | 937 | 287 | 566 | 145 | 293 | 348 | 339 | 267 | 151 | 29 |
| J | Forced Outages (3) | (2,164) | (1,952) | (1,952) | (1,867) | (1,867) | (1,867) | (1,867) | (1,867) | (1,867) | (1,867) |
| K | Adjusted Transmission Security Margin (I+J) | (1,227) | (1,665) | (1,386) | (1,722) | (1,574) | (1,519) | (1,528) | (1,600) | (1,716) | (1,838) |

Notes:

1. Reflects the 2021 Gold Book existing summer capacity plus projected additions, deactivations, and de-rates. For this evaluation wind generation is assumed to have 0 MW output, solar generation is based on the ratio of solar PV nameplate capacity (2021 Gold Book Table I-9a) and solar PV peak reductions (2021 Gold Book Table I-9c). De-rates for run-of-river hydro is included as well as the Oswego Export limit for all lines in-service.
2. Interchanges are based on ERAG MMWG values.
3. Includes de-rates for thermal resources.
4. SCRs are not applied for transmission security analysis of normal operations, but are included for emergency operations.
5. Includes a de-rate of 373 MW for SCRs.

Under transmission security for the 1 in 100 year forecast, **Figure 39** shows that there is insufficient transmission security margin as early as 2022 (line-item I). This deficiency is exacerbated with the inclusion of forced outages (line-item K). The adjusted transmission security margin is deficient beyond the point of meeting the total capability requirement without reserves. For example, changing the operating reserve requirement to 0 MW, the adjusted transmission security margin ranges from 175 MW deficient in 2022 to 724 MW deficient in 2031.

Figure 39: NYCA Summer Transmission Security Margin (NYCA Summer 1-in-100 Peak Forecast - Emergency)

| Line | Item | 1 in 100 Forecast | | | | | | | | | |
|------|--|-------------------|-----------------|-----------------|-----------------|-----------------|-----------------|-----------------|-----------------|-----------------|-----------------|
| | | 2022 | 2023 | 2024 | 2025 | 2026 | 2027 | 2028 | 2029 | 2030 | 2031 |
| A | NYCA Generation (1) | 35,257 | 34,307 | 34,297 | 33,684 | 33,679 | 33,679 | 33,674 | 33,669 | 33,664 | 33,659 |
| B | External Area Interchanges (2) | 1,844 | 1,844 | 1,844 | 1,844 | 1,844 | 1,844 | 1,844 | 1,844 | 1,844 | 1,844 |
| C | SCRs (4), (5) | 822 | 822 | 822 | 822 | 822 | 822 | 822 | 822 | 822 | 822 |
| D | Temperature Based Generation Derates | (437) | (410) | (410) | (390) | (390) | (390) | (390) | (390) | (390) | (390) |
| E | Total Resources (A+B+C+D) | 37,486 | 36,563 | 36,553 | 35,959 | 35,954 | 35,954 | 35,949 | 35,944 | 35,939 | 35,934 |
| F | Load Forecast | (35,870) | (35,569) | (35,264) | (35,073) | (34,909) | (34,852) | (34,856) | (34,924) | (35,039) | (35,164) |
| G | Operating Reserve Requirement | (2,620) | (2,620) | (2,620) | (2,620) | (2,620) | (2,620) | (2,620) | (2,620) | (2,620) | (2,620) |
| H | Total Capability Requirement (F+G) | (38,490) | (38,189) | (37,884) | (37,693) | (37,529) | (37,472) | (37,476) | (37,544) | (37,659) | (37,784) |
| I | Transmission Security Margin (E+H) | (1,004) | (1,626) | (1,331) | (1,734) | (1,575) | (1,518) | (1,527) | (1,600) | (1,720) | (1,850) |
| J | Forced Outages (3) | (2,164) | (1,952) | (1,952) | (1,867) | (1,867) | (1,867) | (1,867) | (1,867) | (1,867) | (1,867) |
| K | Adjusted Transmission Security Margin (I+J) | (3,168) | (3,578) | (3,283) | (3,601) | (3,442) | (3,385) | (3,394) | (3,467) | (3,587) | (3,717) |

Notes:

1. Reflects the 2021 Gold Book existing summer capacity plus projected additions, deactivations, and de-rates. For this evaluation wind generation is assumed to have 0 MW output, solar generation is based on the ratio of solar PV nameplate capacity (2021 Gold Book Table I-9a) and solar PV peak reductions (2021 Gold Book Table I-9c). De-rates for run-of-river hydro is included as well as the Oswego Export limit for all lines in-service.
2. Interchanges are based on ERAG MMWG values.
3. Includes de-rates for thermal resources.
4. SCRs are not applied for transmission security analysis of normal operations, but are included for emergency operations.
5. Includes a de-rate of 373 MW for SCRs.

Figure XX-40: Summary of NYCA Transmission Security Margin



Lower Hudson Valley (Zones G-J) Tipping Points

The Lower Hudson Valley, or southeastern New York (SENY) region, is comprised of Zones G-J and includes the electrical connections to the RECO load in PJM. To determine the tipping point for this area, the most limiting combination of two non-simultaneous contingency events (N-1-1) to the transmission security margin was determined. Design criteria N-1-1 combinations include various combinations of losses of generation and transmission. As the system changes the limiting contingency combination may also change. **Figure 41** shows how the transmissions security margin changes through time in consideration of the most limiting contingency combination for the year being evaluated. In years 2022

and 2023 (prior to the completion of the Segment B public policy project) the most limiting contingency combination to the transmission security margin under peak load conditions is the loss of Leeds-Pleasant Valley (92) 345 kV followed by the loss of Dolson – Rock Tavern (DART44) 345 kV and Coopers Corners – Rock Tavern (CCRT34). For the remainder of the years the contingency combination changes to the loss of Ravenswood 3 followed by the loss of Pleasant Valley-Wood St. 345 kV (F30/F31).

Figure 41: Lower Hudson Valley Summer Transmission Security Margin (Summer Baseline Peak Forecast - Normal)

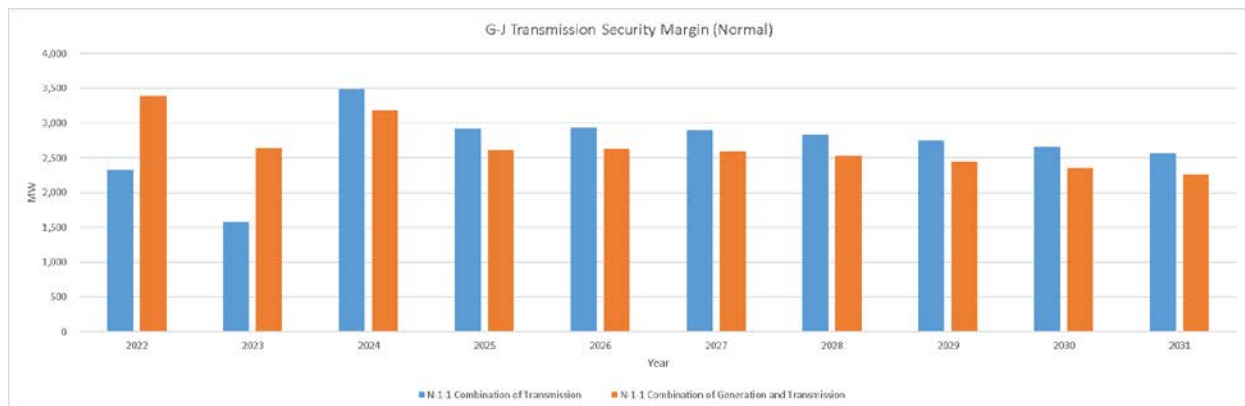

Figure 42 shows the calculation of the lower Hudson Valley transmission security margin for summer baseline peakload (normal) conditions. The transmission security margin ranges from 2,325 MW (2022) to 2,260 MW (2031). In consideration of Considering the baseline peakload transmission security margin (line item P), multiple outages the values show that it is feasible lower Hudson Valley would be required to not tip in consideration of the potential outage of any generator in the area. The largest generator in the area is Cricket Valley with a summer capability of 1,088 MW. With the outage of this entire plant, the transmission system over its security margin in 2031 reduces to 1,172 MW.

An additional evaluation shown in **Figure 42** is the impact of the historical forced outage rate of NYCA thermal generation on the transmission security margin. Also, while SCRs are generally not included for a Transmission Security evaluation, they are used of transmission security under normal transfer criteria, the impact of SCRs is accounted for in this forced outage rate evaluation, adjusted transmission security margin. The adjusted transmission security margin (line item S) shows that sufficient margin exists under this condition. In consideration of generation outages consistent with the historical forced outage of Cricket Valley (1,088 MW) on top of the adjusted rates would not result in “tipping” beyond transmission security limits, with a margin (line item S), of 1,274 MW in 2022 growing to 1,450 MW in 2031 the margin reduces to 362 MW.

Figure 42: G-J Summer Transmission Security Margin (Summer Baseline Peak Forecast - Normal)

| | | Peak Load Forecast | | | | | | | | | |
|------|--|--------------------|-----------------|-----------------|-----------------|-----------------|-----------------|-----------------|-----------------|-----------------|-----------------|
| Line | Item | 2022 | 2023 | 2024 | 2025 | 2026 | 2027 | 2028 | 2029 | 2030 | 2031 |
| A | G-J Load Forecast | (15,311) | (15,231) | (15,163) | (15,120) | (15,100) | (15,142) | (15,210) | (15,294) | (15,381) | (15,474) |
| B | RECO Load | (397) | (397) | (397) | (397) | (397) | (397) | (397) | (397) | (397) | (397) |
| C | Total Load (A+B) | (15,708) | (15,628) | (15,560) | (15,517) | (15,497) | (15,539) | (15,607) | (15,691) | (15,778) | (15,871) |
| D | UPNY-SENY Limit | 3,200 | 3,200 | 5,725 | 5,725 | 5,725 | 5,725 | 5,725 | 5,725 | 5,725 | 5,725 |
| E | ABC PARs to J | (11) | (11) | (11) | (11) | (11) | (11) | (11) | (11) | (11) | (11) |
| F | K - SENY | 95 | 95 | 95 | 95 | 95 | 95 | 95 | 95 | 95 | 95 |
| G | Total SENY AC Import (D+E+F) | 3,284 | 3,284 | 5,809 | 5,809 | 5,809 | 5,809 | 5,809 | 5,809 | 5,809 | 5,809 |
| H | Loss of Source Contingency | 0 | 0 | (980) | (980) | (980) | (980) | (980) | (980) | (980) | (980) |
| I | Resource Need (C+G+H) | (12,424) | (12,344) | (10,731) | (10,688) | (10,668) | (10,710) | (10,778) | (10,862) | (10,949) | (11,042) |
| J | <i>Resources needed after N-1-1 (C+G)</i> | (12,424) | (12,344) | (9,751) | (9,708) | (9,688) | (9,730) | (9,798) | (9,882) | (9,969) | (10,062) |
| K | G-J Generation (1) | 14,434 | 13,603 | 13,602 | 12,988 | 12,988 | 12,988 | 12,988 | 12,988 | 12,987 | 12,987 |
| L | Temperature Based Generation Derates | 0 | 0 | 0 | 0 | 0 | 0 | 0 | 0 | 0 | 0 |
| M | Net ICAP External Imports | 315 | 315 | 315 | 315 | 315 | 315 | 315 | 315 | 315 | 315 |
| N | Total Resources Available (K+L+M) | 14,749 | 13,918 | 13,917 | 13,303 | 13,303 | 13,303 | 13,303 | 13,303 | 13,302 | 13,302 |
| O | <i>Resources available after N-1-1 (H+N)</i> | 14,749 | 13,918 | 12,937 | 12,323 | 12,323 | 12,323 | 12,323 | 12,323 | 12,322 | 12,322 |
| P | Transmission Security Margin (I+N) | 2,325 | 1,574 | 3,186 | 2,615 | 2,635 | 2,593 | 2,525 | 2,441 | 2,353 | 2,260 |
| Q | SCRs (3), (4) | 288 | 288 | 288 | 288 | 288 | 288 | 288 | 288 | 288 | 288 |
| R | Forced Outages (2) | (1,339) | (1,182) | (1,182) | (1,098) | (1,098) | (1,098) | (1,098) | (1,098) | (1,098) | (1,098) |
| S | Adjusted Transmission Security Margin (P+Q+R) (3) | 1,274 | 680 | 2,292 | 1,805 | 1,825 | 1,783 | 1,715 | 1,631 | 1,543 | 1,450 |

Notes:

1. Reflects the 2021 Gold Book existing summer capacity plus projected additions, deactivations, and de-rates. For this evaluation wind generation is assumed to have 0 MW output, solar generation is based on the ratio of solar PV nameplate capacity (2021 Gold Book Table I-9a) and solar PV peak reductions (2021 Gold Book Table I-9c). De-rates for run-of-river hydro is included as well as the Oswego Export limit for all lines in-service.
2. Includes de-rates for thermal resources.
3. Special Case Resources (SCRs) are not applied for transmission security analysis of normal operations.
4. Includes a de-rate of 242 MW for SCRs.

| | | Peak Load Forecast | | | | | | | | | |
|------|--|--------------------|-----------------|-----------------|-----------------|-----------------|-----------------|-----------------|-----------------|-----------------|-----------------|
| Line | Item | 2022 | 2023 | 2024 | 2025 | 2026 | 2027 | 2028 | 2029 | 2030 | 2031 |
| A | G-J Load Forecast | (15,311) | (15,231) | (15,163) | (15,120) | (15,100) | (15,142) | (15,210) | (15,294) | (15,381) | (15,474) |
| B | RECO Load | (397) | (397) | (397) | (397) | (397) | (397) | (397) | (397) | (397) | (397) |
| C | Total Load (A+B) | (15,708) | (15,628) | (15,560) | (15,517) | (15,497) | (15,539) | (15,607) | (15,691) | (15,778) | (15,871) |
| D | UPNY-SENY Limit (5) | 3,200 | 3,200 | 5,725 | 5,725 | 5,725 | 5,725 | 5,725 | 5,725 | 5,725 | 5,725 |
| E | ABC PARs to J | (11) | (11) | (11) | (11) | (11) | (11) | (11) | (11) | (11) | (11) |
| F | K - SENY | 95 | 95 | 95 | 95 | 95 | 95 | 95 | 95 | 95 | 95 |
| G | Total SENY AC Import (D+E+F) | 3,284 | 3,284 | 5,809 | 5,809 | 5,809 | 5,809 | 5,809 | 5,809 | 5,809 | 5,809 |
| H | Loss of Source Contingency | 0 | 0 | (980) | (980) | (980) | (980) | (980) | (980) | (980) | (980) |
| I | Resource Need (C+G+H) | (12,424) | (12,344) | (10,731) | (10,688) | (10,668) | (10,710) | (10,778) | (10,862) | (10,949) | (11,042) |
| J | <i>Resources needed after N-1-1 (C+G)</i> | (12,424) | (12,344) | (9,751) | (9,708) | (9,688) | (9,730) | (9,798) | (9,882) | (9,969) | (10,062) |
| K | G-J Generation (1) | 14,434 | 13,603 | 13,602 | 12,988 | 12,988 | 12,988 | 12,988 | 12,988 | 12,987 | 12,987 |
| L | Temperature Based Generation Derates | 0 | 0 | 0 | 0 | 0 | 0 | 0 | 0 | 0 | 0 |
| M | Net ICAP External Imports | 315 | 315 | 315 | 315 | 315 | 315 | 315 | 315 | 315 | 315 |
| N | Total Resources Available (K+L+M) | 14,749 | 13,918 | 13,917 | 13,303 | 13,303 | 13,303 | 13,303 | 13,303 | 13,302 | 13,302 |
| O | <i>Resources available after N-1-1 (H+N)</i> | 14,749 | 13,918 | 12,937 | 12,323 | 12,323 | 12,323 | 12,323 | 12,323 | 12,322 | 12,322 |
| P | Transmission Security Margin (I+N) | 2,325 | 1,574 | 3,186 | 2,615 | 2,635 | 2,593 | 2,525 | 2,441 | 2,353 | 2,260 |
| Q | SCRs (3), (4) | 288 | 288 | 288 | 288 | 288 | 288 | 288 | 288 | 288 | 288 |
| R | Forced Outages (2) | (1,339) | (1,182) | (1,182) | (1,098) | (1,098) | (1,098) | (1,098) | (1,098) | (1,098) | (1,098) |
| S | Adjusted Transmission Security Margin (P+Q+R) (3) | 1,274 | 680 | 2,292 | 1,805 | 1,825 | 1,783 | 1,715 | 1,631 | 1,543 | 1,450 |

Notes:

1. Reflects the 2021 Gold Book existing summer capacity plus projected additions, deactivations, and de-rates. For this evaluation wind generation is assumed to have 0 MW output, solar generation is based on the ratio of solar PV nameplate capacity (2021 Gold Book Table I-9a) and solar PV peak reductions (2021 Gold Book Table I-9c). De-rates for run-of-river hydro is included as well as the Oswego Export limit for all lines in-service.
2. Includes de-rates for thermal resources.
3. Special Case Resources (SCRs) are not applied for transmission security analysis of normal operations.
4. Includes a de-rate of 242 MW for SCRs.
5. Limits in 2022 and 2023 are based on limits from the summer peak 2023 representations. Limits for 2024 through 2031 are based on the summer peak 2025 representations.

Figure 43 and Figure 44 show the transmission security margin for the 1-in-10 year load conditions (also known as 90/10 or 90th percentile load) and 1-in-100 year load conditions (respectively) under the assumption that the system is in an emergency condition. An additional evaluation shown in each figure is the impacted of the historical forced outage rate of G-J thermal generation on the transmission security margin. Under 1-in-10 year load conditions the adjusted transmission security margin (line item S) shows that under 90/10 the system does generation outages consistent with the historical forced outage rates would not tip under these conditions. However, under result in “tipping” beyond transmission security limits, with a margin of 1,228 MW in 2022 growing to 1,402 MW in 2031. Under 1-in-100 load conditions the system historical forced outage rate does “tip under” the adjusted transmission security margin (line item S) system in 2023. However, the remaining years of the study period is sufficient primarily due to the additional transmission capability of the Segment B public policy project.

Figure 43: G-J Summer Transmission Security Margin (Summer 1-in-10 (90/10) Peak Forecast - Emergency)

| 90th Percentile Load Forecast | | | | | | | | | | | |
|-------------------------------|--|-----------------|-----------------|-----------------|-----------------|-----------------|-----------------|-----------------|-----------------|-----------------|-----------------|
| Line | Item | 2022 | 2023 | 2024 | 2025 | 2026 | 2027 | 2028 | 2029 | 2030 | 2031 |
| A | G-J Load Forecast | (16,046) | (15,961) | (15,888) | (15,843) | (15,822) | (15,865) | (15,935) | (16,023) | (16,115) | (16,212) |
| B | RECO Load | (397) | (397) | (397) | (397) | (397) | (397) | (397) | (397) | (397) | (397) |
| C | Total Load (A+B) | (16,443) | (16,358) | (16,285) | (16,240) | (16,219) | (16,262) | (16,332) | (16,420) | (16,512) | (16,609) |
| D | UPNY-SENY Limit | 3,925 | 3,925 | 5,450 | 5,450 | 5,450 | 5,450 | 5,450 | 5,450 | 5,450 | 5,450 |
| E | ABC PARs to J | (11) | (11) | (11) | (11) | (11) | (11) | (11) | (11) | (11) | (11) |
| F | K - SENY | 155 | 155 | 155 | 155 | 155 | 155 | 155 | 155 | 155 | 155 |
| G | Total SENY AC Import (D+E+F) | 4,069 | 4,069 | 5,594 | 5,594 | 5,594 | 5,594 | 5,594 | 5,594 | 5,594 | 5,594 |
| H | Loss of Source Contingency | 0 | 0 | 0 | 0 | 0 | 0 | 0 | 0 | 0 | 0 |
| I | Resource Need (C+G+H) | (12,374) | (12,289) | (10,691) | (10,646) | (10,625) | (10,668) | (10,738) | (10,826) | (10,918) | (11,015) |
| J | <i>Resources needed after N-1-1 (C+G)</i> | (12,374) | (12,289) | (10,691) | (10,646) | (10,625) | (10,668) | (10,738) | (10,826) | (10,918) | (11,015) |
| K | G-J Generation (1) | 14,434 | 13,603 | 13,602 | 12,988 | 12,988 | 12,988 | 12,988 | 12,988 | 12,987 | 12,987 |
| L | Temperature Based Generation Derates | (96) | (85) | (85) | (75) | (75) | (75) | (75) | (75) | (75) | (75) |
| M | Net ICAP External Imports | 315 | 315 | 315 | 315 | 315 | 315 | 315 | 315 | 315 | 315 |
| N | SCRs (3), (4) | 288 | 288 | 288 | 288 | 288 | 288 | 288 | 288 | 288 | 288 |
| O | Total Resources Available (K+L+M+N) | 14,941 | 14,121 | 14,120 | 13,516 | 13,516 | 13,516 | 13,516 | 13,515 | 13,515 | 13,515 |
| P | <i>Resources available after N-1-1 (H+O)</i> | 14,941 | 14,121 | 14,120 | 12,225 | 12,225 | 12,225 | 12,224 | 12,224 | 12,224 | 12,224 |
| Q | Transmission Security Margin (I+O) | 2,567 | 1,832 | 3,429 | 2,870 | 2,891 | 2,848 | 2,778 | 2,689 | 2,597 | 2,500 |
| R | Forced Outages (2) | (1,339) | (1,182) | (1,181) | (1,098) | (1,098) | (1,098) | (1,098) | (1,098) | (1,098) | (1,098) |
| S | Adjusted Transmission Security Margin (Q+R) | 1,228 | 650 | 2,248 | 1,772 | 1,793 | 1,750 | 1,680 | 1,591 | 1,499 | 1,402 |

Notes:

1. Reflects the 2021 Gold Book existing summer capacity plus projected additions, deactivations, and de-rates. For this evaluation wind generation is assumed to have 0 MW output, solar generation is based on the ratio of solar PV nameplate capacity (2021 Gold Book Table I-9a) and solar PV peak reductions (2021 Gold Book Table I-9c). De-rates for run-of-river hydro is included as well as the Oswego Export limit for all lines in-service.
2. Includes de-rates for thermal resources.
3. SCRs are not applied for transmission security analysis of normal operations, but are included for emergency operations.
4. Includes a de-rate of 242 MW for SCRs.

| 90th Percentile Load Forecast | | | | | | | | | | | |
|-------------------------------|--|-----------------|-----------------|-----------------|-----------------|-----------------|-----------------|-----------------|-----------------|-----------------|-----------------|
| Line | Item | 2022 | 2023 | 2024 | 2025 | 2026 | 2027 | 2028 | 2029 | 2030 | 2031 |
| A | G-J Load Forecast | (16,046) | (15,961) | (15,888) | (15,843) | (15,822) | (15,865) | (15,935) | (16,023) | (16,115) | (16,212) |
| B | RECO Load | (397) | (397) | (397) | (397) | (397) | (397) | (397) | (397) | (397) | (397) |
| C | Total Load (A+B) | (16,443) | (16,358) | (16,285) | (16,240) | (16,219) | (16,262) | (16,332) | (16,420) | (16,512) | (16,609) |
| D | UPNY-SENY Limit (5) | 3,925 | 3,925 | 5,450 | 5,450 | 5,450 | 5,450 | 5,450 | 5,450 | 5,450 | 5,450 |
| E | ABC PARs to J | (11) | (11) | (11) | (11) | (11) | (11) | (11) | (11) | (11) | (11) |
| F | K - SENY | 155 | 155 | 155 | 155 | 155 | 155 | 155 | 155 | 155 | 155 |
| G | Total SENY AC Import (D+E+F) | 4,069 | 4,069 | 5,594 | 5,594 | 5,594 | 5,594 | 5,594 | 5,594 | 5,594 | 5,594 |
| H | Loss of Source Contingency | 0 | 0 | 0 | 0 | 0 | 0 | 0 | 0 | 0 | 0 |
| I | Resource Need (C+G+H) | (12,374) | (12,289) | (10,691) | (10,646) | (10,625) | (10,668) | (10,738) | (10,826) | (10,918) | (11,015) |
| J | <i>Resources needed after N-1-1 (C+G)</i> | (12,374) | (12,289) | (10,691) | (10,646) | (10,625) | (10,668) | (10,738) | (10,826) | (10,918) | (11,015) |
| K | G-J Generation (1) | 14,434 | 13,603 | 13,602 | 12,988 | 12,988 | 12,988 | 12,988 | 12,988 | 12,987 | 12,987 |
| L | Temperature Based Generation Derates | (96) | (85) | (85) | (75) | (75) | (75) | (75) | (75) | (75) | (75) |
| M | Net ICAP External Imports | 315 | 315 | 315 | 315 | 315 | 315 | 315 | 315 | 315 | 315 |
| N | SCRs (3), (4) | 288 | 288 | 288 | 288 | 288 | 288 | 288 | 288 | 288 | 288 |
| O | Total Resources Available (K+L+M+N) | 14,941 | 14,121 | 14,120 | 13,516 | 13,516 | 13,516 | 13,516 | 13,515 | 13,515 | 13,515 |
| P | <i>Resources available after N-1-1 (H+O)</i> | 14,941 | 14,121 | 14,120 | 12,225 | 12,225 | 12,225 | 12,224 | 12,224 | 12,224 | 12,224 |
| Q | Transmission Security Margin (I+O) | 2,567 | 1,832 | 3,429 | 2,870 | 2,891 | 2,848 | 2,778 | 2,689 | 2,597 | 2,500 |
| R | Forced Outages (2) | (1,339) | (1,182) | (1,181) | (1,098) | (1,098) | (1,098) | (1,098) | (1,098) | (1,098) | (1,098) |
| S | Adjusted Transmission Security Margin (Q+R) | 1,228 | 650 | 2,248 | 1,772 | 1,793 | 1,750 | 1,680 | 1,591 | 1,499 | 1,402 |

Notes:

1. Reflects the 2021 Gold Book existing summer capacity plus projected additions, deactivations, and de-rates. For this evaluation wind generation is assumed to have 0 MW output, solar generation is based on the ratio of solar PV nameplate capacity (2021 Gold Book Table I-9a) and solar PV peak reductions (2021 Gold Book Table I-9c). De-rates for run-of-river hydro is included as well as the Oswego Export limit for all lines in-service.
2. Includes de-rates for thermal resources.
3. SCRs are not applied for transmission security analysis of normal operations, but are included for emergency operations.
4. Includes a de-rate of 242 MW for SCRs.
5. Limits in 2022 and 2023 are based on limits from the summer peak 2023 representations. Limits for 2024 through 2031 are based on the summer peak 2025 representations.

Figure 44: G-J Summer Transmission Security Margin (Summer 1-in-100 Peak Forecast - Emergency)

| | | 1 in 100 Forecast | | | | | | | | | |
|--|--|-------------------|-----------------|-----------------|-----------------|-----------------|-----------------|-----------------|-----------------|-----------------|-----------------|
| Line | Item | 2022 | 2023 | 2024 | 2025 | 2026 | 2027 | 2028 | 2029 | 2030 | 2031 |
| A | G-J Load Forecast | (16,778) | (16,690) | (16,614) | (16,568) | (16,545) | (16,590) | (16,663) | (16,754) | (16,849) | (16,951) |
| B | RECO Load | (443) | (443) | (443) | (443) | (443) | (443) | (443) | (443) | (443) | (443) |
| Total Load (A+B) | | (17,221) | (17,133) | (17,057) | (17,011) | (16,988) | (17,033) | (17,106) | (17,197) | (17,292) | (17,394) |
| D | UPNY-SENY Limit | 3,925 | 3,925 | 5,450 | 5,450 | 5,450 | 5,450 | 5,450 | 5,450 | 5,450 | 5,450 |
| E | ABC PARs to J | (11) | (11) | (11) | (11) | (11) | (11) | (11) | (11) | (11) | (11) |
| F | K - SENY | 155 | 155 | 155 | 155 | 155 | 155 | 155 | 155 | 155 | 155 |
| Total SENY AC Import (D+E+F) | | 4,069 | 4,069 | 5,594 | 5,594 | 5,594 | 5,594 | 5,594 | 5,594 | 5,594 | 5,594 |
| H | Loss of Source Contingency | 0 | 0 | 0 | 0 | 0 | 0 | 0 | 0 | 0 | 0 |
| I | Resource Need (C+G+H) | (13,152) | (13,064) | (11,463) | (11,417) | (11,394) | (11,439) | (11,512) | (11,603) | (11,698) | (11,800) |
| J | <i>Resources needed after N-1-1 (C+G)</i> | (13,152) | (13,064) | (11,463) | (11,417) | (11,394) | (11,439) | (11,512) | (11,603) | (11,698) | (11,800) |
| K | G-J Generation (1) | 14,434 | 13,603 | 13,602 | 12,988 | 12,988 | 12,988 | 12,988 | 12,988 | 12,987 | 12,987 |
| L | Temperature Based Generation Derates | (201) | (179) | (179) | (159) | (159) | (159) | (159) | (159) | (159) | (159) |
| M | Net ICAP External Imports | 315 | 315 | 315 | 315 | 315 | 315 | 315 | 315 | 315 | 315 |
| N | SCRs (3), (4) | 288 | 288 | 288 | 288 | 288 | 288 | 288 | 288 | 288 | 288 |
| O | Total Resources Available (K+L+M+N) | 14,836 | 14,027 | 14,026 | 13,432 | 13,432 | 13,432 | 13,432 | 13,431 | 13,431 | 13,431 |
| P | <i>Resources available after N-1-1 (H+O)</i> | 14,836 | 14,027 | 14,026 | 13,432 | 13,432 | 13,432 | 13,432 | 13,431 | 13,431 | 13,431 |
| Transmission Security Margin (I+O) | | 1,685 | 963 | 2,564 | 2,016 | 2,038 | 1,993 | 1,920 | 1,829 | 1,733 | 1,631 |
| R | Forced Outages (2) | (1,339) | (1,182) | (1,098) | (1,098) | (1,098) | (1,098) | (1,098) | (1,098) | (1,098) | (1,098) |
| Adjusted Transmission Security Margin (Q+R) | | 346 | (219) | 1,466 | 918 | 940 | 895 | 822 | 731 | 635 | 533 |

Notes:

- Reflects the 2021 Gold Book existing summer capacity plus projected additions, deactivations, and de-rates. For this evaluation wind generation is assumed to have 0 MW output, solar generation is based on the ratio of solar PV nameplate capacity (2021 Gold Book Table I-9a) and solar PV peak reductions (2021 Gold Book Table I-9c). De-rates for run-of-river hydro is included as well as the Oswego Export limit for all lines in-service.
- Includes de-rates for thermal resources.
- SCRs are not applied for transmission security analysis of normal operations, but are included for emergency operations.
- Includes a de-rate of 242 MW for SCRs.

| | | 1 in 100 Forecast | | | | | | | | | |
|--|--|-------------------|-----------------|-----------------|-----------------|-----------------|-----------------|-----------------|-----------------|-----------------|-----------------|
| Line | Item | 2022 | 2023 | 2024 | 2025 | 2026 | 2027 | 2028 | 2029 | 2030 | 2031 |
| A | G-J Load Forecast | (16,778) | (16,690) | (16,614) | (16,568) | (16,545) | (16,590) | (16,663) | (16,754) | (16,849) | (16,951) |
| B | RECO Load | (443) | (443) | (443) | (443) | (443) | (443) | (443) | (443) | (443) | (443) |
| Total Load (A+B) | | (17,221) | (17,133) | (17,057) | (17,011) | (16,988) | (17,033) | (17,106) | (17,197) | (17,292) | (17,394) |
| D | UPNY-SENY Limit (5) | 3,925 | 3,925 | 5,450 | 5,450 | 5,450 | 5,450 | 5,450 | 5,450 | 5,450 | 5,450 |
| E | ABC PARs to J | (11) | (11) | (11) | (11) | (11) | (11) | (11) | (11) | (11) | (11) |
| F | K - SENY | 155 | 155 | 155 | 155 | 155 | 155 | 155 | 155 | 155 | 155 |
| Total SENY AC Import (D+E+F) | | 4,069 | 4,069 | 5,594 | 5,594 | 5,594 | 5,594 | 5,594 | 5,594 | 5,594 | 5,594 |
| H | Loss of Source Contingency | 0 | 0 | 0 | 0 | 0 | 0 | 0 | 0 | 0 | 0 |
| I | Resource Need (C+G+H) | (13,152) | (13,064) | (11,463) | (11,417) | (11,394) | (11,439) | (11,512) | (11,603) | (11,698) | (11,800) |
| J | <i>Resources needed after N-1-1 (C+G)</i> | (13,152) | (13,064) | (11,463) | (11,417) | (11,394) | (11,439) | (11,512) | (11,603) | (11,698) | (11,800) |
| K | G-J Generation (1) | 14,434 | 13,603 | 13,602 | 12,988 | 12,988 | 12,988 | 12,988 | 12,988 | 12,987 | 12,987 |
| L | Temperature Based Generation Derates | (201) | (179) | (179) | (159) | (159) | (159) | (159) | (159) | (159) | (159) |
| M | Net ICAP External Imports | 315 | 315 | 315 | 315 | 315 | 315 | 315 | 315 | 315 | 315 |
| N | SCRs (3), (4) | 288 | 288 | 288 | 288 | 288 | 288 | 288 | 288 | 288 | 288 |
| O | Total Resources Available (K+L+M+N) | 14,836 | 14,027 | 14,026 | 13,432 | 13,432 | 13,432 | 13,432 | 13,431 | 13,431 | 13,431 |
| P | <i>Resources available after N-1-1 (H+O)</i> | 14,836 | 14,027 | 14,026 | 13,432 | 13,432 | 13,432 | 13,432 | 13,431 | 13,431 | 13,431 |
| Transmission Security Margin (I+O) | | 1,685 | 963 | 2,564 | 2,016 | 2,038 | 1,993 | 1,920 | 1,829 | 1,733 | 1,631 |
| R | Forced Outages (2) | (1,339) | (1,182) | (1,098) | (1,098) | (1,098) | (1,098) | (1,098) | (1,098) | (1,098) | (1,098) |
| Adjusted Transmission Security Margin (Q+R) | | 346 | (219) | 1,466 | 918 | 940 | 895 | 822 | 731 | 635 | 533 |

Notes:

- Reflects the 2021 Gold Book existing summer capacity plus projected additions, deactivations, and de-rates. For this evaluation wind generation is assumed to have 0 MW output, solar generation is based on the ratio of solar PV nameplate capacity (2021 Gold Book Table I-9a) and solar PV peak reductions (2021 Gold Book Table I-9c). De-rates for run-of-river hydro is included as well as the Oswego Export limit for all lines in-service.
- Includes de-rates for thermal resources.
- SCRs are not applied for transmission security analysis of normal operations, but are included for emergency operations.
- Includes a de-rate of 242 MW for SCRs.
- Limits in 2022 and 2023 are based on limits from the summer peak 2023 representations. Limits for 2024 through 2031 are based on the summer peak 2025 representations.

Figure 45: Summary of Lower Hudson Valley Summer Transmission Security Margin

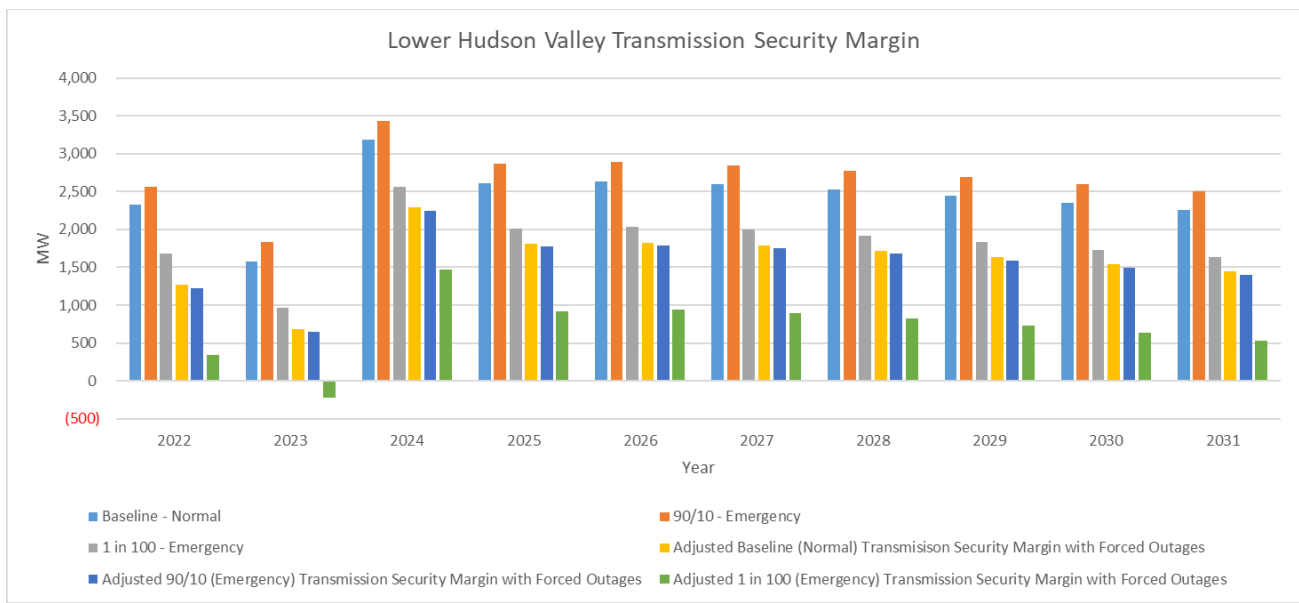
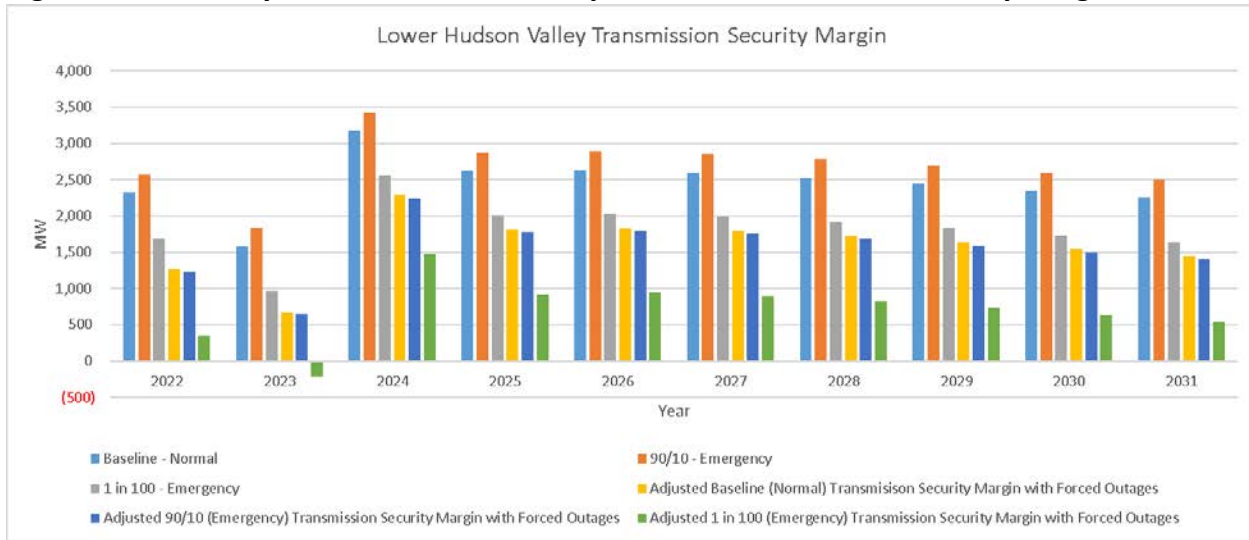

New York City (Zone J) Tipping Points

Within the Con Edison service territory, the 345 kV transmission system along with specific portions of the 138 kV transmission system are designed for the occurrence of two non-simultaneous contingencies and a return to normal.³⁷ The analysis for this is noted as N-1-1-0, and the CRP notes a transmission security margin of 50 MW in Zone J.³⁸ Figure XX provides a summary of the zone J transmission security margin.

The tipping points for Zone J are evaluated under the most limiting N-1-1-0 contingency combination to the transmission security margin, which is loss of Ravenswood 3 followed by the loss of Mott Haven – Rainey 345 kV (Q12). **Figure 47** shows the transmission security margin under baseline load conditions with this contingency combination, which ranges from 1,174 MW in 2022 to 42 MW in 2031). The most limiting contingency combination to transmission security margin in Zone J is the loss of Ravenswood 3 and ~~Dunwoodie~~-Mott Haven – Rainey (Q12) 345 kV. The power flowing into J from other NYCA zones is shown in line item B. Other contingency combinations result in changing the power flowing into J from other NYCA zones. For example, in considering the possible combinations of N-1-1-0 events these can include a mix of generation and transmission, two transmission events, or two generation events. **Figure 46** shows the transmission security margin for the contingency combinations of: ~~(1)~~ Ravenswood 3 and ~~Dunwoodie~~-Mott Haven – Rainey (Q12) 345 kV, ~~(2)~~ Ravenswood 3 and Bayonne Energy Center, and ~~(3)~~ Sprain Brook-W. 49th St. 345 kV (M51 and M52). For Ravenswood 3 and Bayonne Energy Center the power flowing into J from other NYCA zones is 4,717 MW. For Sprain Brook-W. 49th St. 345 kV (M51 and M52) the power flowing into J from other NYCA zones is 3,191 MW. As seen in **Figure 46**, the selecting an interface flow with the lowest value (3,191 MW for the loss of M51/M52) does not result in the smallest transmission security margin. In this specific example, all years show the loss of M51/M52 with the largest transmission security margin.

Considering the baseline peak load transmission security margin (42 MW observed in 2031), many different losses of generation or load increases will exceed the transmission security margin.

³⁷ Con Edison, [TP-7100-18 Transmission Planning Criteria](#), dated August 2019.

³⁸ https://www.nyiso.com/documents/20142/19415353/07_2020-2021RPP_PostRNABaseCaseUpdates.pdf/

Figure 46: Impact of Contingency Combination on Zone J Transmission Security Margin

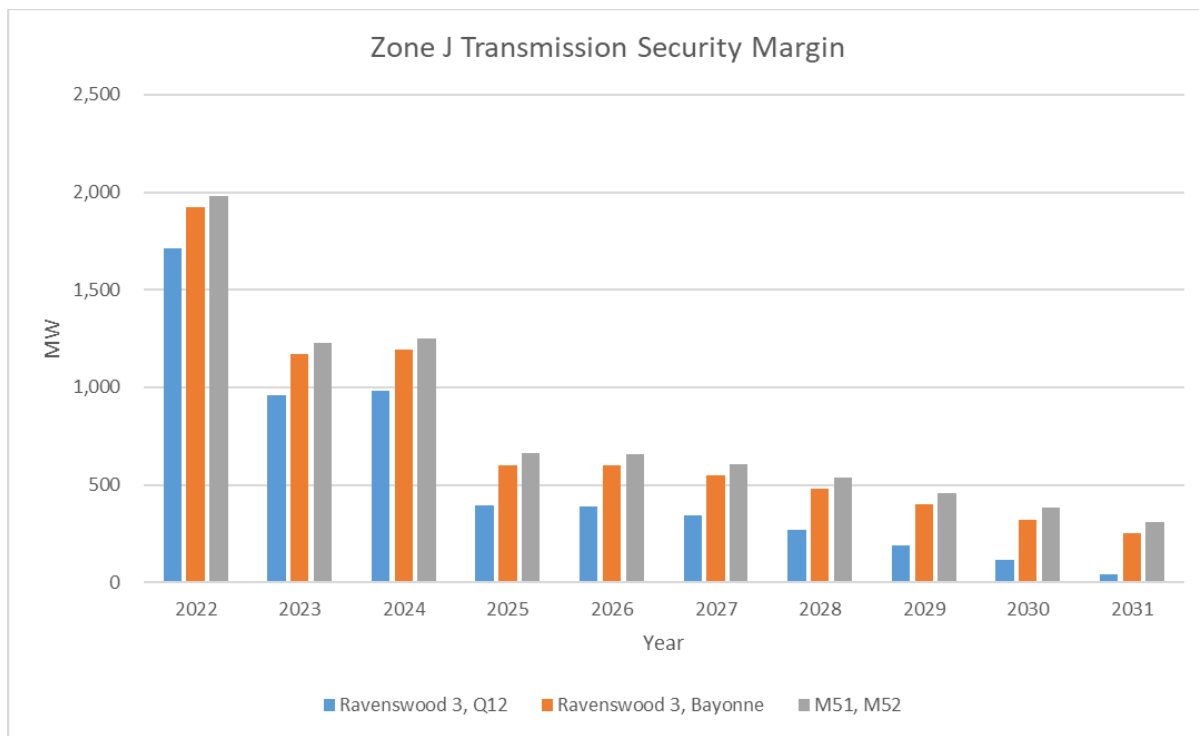
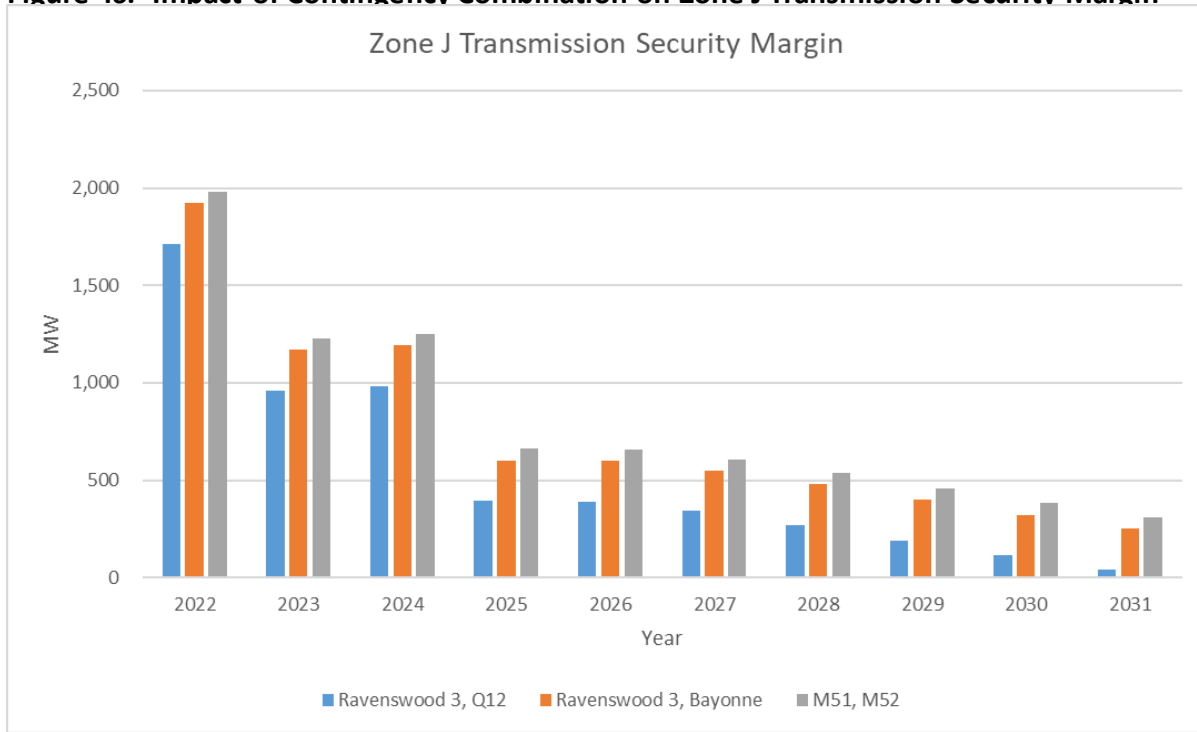

An additional evaluation shown in **Figure 47** is the impact of the historical forced outage rate of NYCA thermal generation on the transmission security margin. Also, while SCRs are generally not included for a Transmission Security evaluation, they are used of transmission security under normal transfer criteria.

the impact of SCRs is accounted for in this forced outage rate evaluation adjusted transmission security margin. The adjusted transmission security margin (line_item P) shows that insufficient generation outages consistent with the historical forced outage rates of thermal generation would “tip” beyond the transmission security margin is observed limits in 2028 with a 20 MW deficiency which grows to a deficiency of 250 MW by 2031.

Figure 47: Zone J Summer Transmission Security Margin (Summer Baseline Peak Forecast - Normal)

| | | Peak Load Forecast | | | | | | | | | |
|------|---|--------------------|----------|----------|----------|----------|----------|----------|----------|----------|----------|
| Line | Item | 2022 | 2023 | 2024 | 2025 | 2026 | 2027 | 2028 | 2029 | 2030 | 2031 |
| A | Zone J Load Forecast | (11,116) | (11,075) | (11,052) | (11,029) | (11,031) | (11,082) | (11,151) | (11,232) | (11,308) | (11,381) |
| B | I+K to J | 3,904 | 3,904 | 3,904 | 3,904 | 3,904 | 3,904 | 3,904 | 3,904 | 3,904 | 3,904 |
| C | ABC PARs to J | (11) | (11) | (11) | (11) | (11) | (11) | (11) | (11) | (11) | (11) |
| D | Total J AC Import (B+C) | 3,893 | 3,893 | 3,893 | 3,893 | 3,893 | 3,893 | 3,893 | 3,893 | 3,893 | 3,893 |
| E | Loss of Source Contingency | (980) | (980) | (980) | (980) | (980) | (980) | (980) | (980) | (980) | (980) |
| F | Resource Need (A+D+E) | (8,203) | (8,162) | (8,139) | (8,116) | (8,118) | (8,169) | (8,238) | (8,319) | (8,395) | (8,468) |
| G | Resources needed after N-1-1 (A+D) | (7,223) | (7,182) | (7,159) | (7,136) | (7,138) | (7,189) | (7,258) | (7,339) | (7,415) | (7,488) |
| H | J Generation (1) | 9,602 | 8,809 | 8,809 | 8,195 | 8,195 | 8,195 | 8,195 | 8,195 | 8,195 | 8,195 |
| I | Temperature Based Generation Derates (2) | 0 | 0 | 0 | 0 | 0 | 0 | 0 | 0 | 0 | 0 |
| J | Net ICAP External Imports | 315 | 315 | 315 | 315 | 315 | 315 | 315 | 315 | 315 | 315 |
| K | Total Resources Available (H+I+J) | 9,917 | 9,124 | 9,124 | 8,510 | 8,510 | 8,510 | 8,510 | 8,510 | 8,510 | 8,510 |
| L | Resources available after N-1-1 (E+K) | 8,937 | 8,144 | 8,144 | 7,530 | 7,530 | 7,530 | 7,530 | 7,530 | 7,530 | 7,530 |
| M | Transmission Security Margin (F+K) | 1,714 | 962 | 985 | 394 | 392 | 341 | 272 | 191 | 115 | 42 |
| N | SCRs (3), (4) | 223 | 223 | 223 | 223 | 223 | 223 | 223 | 223 | 223 | 223 |
| O | Forced Outages (2) | (744) | (599) | (599) | (515) | (515) | (515) | (515) | (515) | (515) | (515) |
| P | Adjusted Transmission Security Margin (M+N+O) (3) | 1,193 | 586 | 609 | 102 | 100 | 49 | (20) | (101) | (177) | (250) |

Notes:

1. Reflects the 2021 Gold Book existing summer capacity plus projected additions, deactivations, and de-rates. For this evaluation wind generation is assumed to have 0 MW output, solar generation is based on the ratio of solar PV nameplate capacity (2021 Gold Book Table I-9a) and solar PV peak reductions (2021 Gold Book Table I-9c). De-rates for run-of-river hydro is included as well as the Oswego Export limit for all lines in-service.
2. Includes de-rates for thermal resources.
3. Special Case Resources (SCRs) are not applied for transmission security analysis of normal operations.
4. Includes a de-rate of 205 MW for SCRs.

| | | Peak Load Forecast | | | | | | | | | |
|------|---|--------------------|----------|----------|----------|----------|----------|----------|----------|----------|----------|
| Line | Item | 2022 | 2023 | 2024 | 2025 | 2026 | 2027 | 2028 | 2029 | 2030 | 2031 |
| A | Zone J Load Forecast | (11,116) | (11,075) | (11,052) | (11,029) | (11,031) | (11,082) | (11,151) | (11,232) | (11,308) | (11,381) |
| B | I+K to J (5) | 3,904 | 3,904 | 3,904 | 3,904 | 3,904 | 3,904 | 3,904 | 3,904 | 3,904 | 3,904 |
| C | ABC PARs to J | (11) | (11) | (11) | (11) | (11) | (11) | (11) | (11) | (11) | (11) |
| D | Total J AC Import (B+C) | 3,893 | 3,893 | 3,893 | 3,893 | 3,893 | 3,893 | 3,893 | 3,893 | 3,893 | 3,893 |
| E | Loss of Source Contingency | (980) | (980) | (980) | (980) | (980) | (980) | (980) | (980) | (980) | (980) |
| F | Resource Need (A+D+E) | (8,203) | (8,162) | (8,139) | (8,116) | (8,118) | (8,169) | (8,238) | (8,319) | (8,395) | (8,468) |
| G | Resources needed after N-1-1 (A+D) | (7,223) | (7,182) | (7,159) | (7,136) | (7,138) | (7,189) | (7,258) | (7,339) | (7,415) | (7,488) |
| H | J Generation (1) | 9,602 | 8,809 | 8,809 | 8,195 | 8,195 | 8,195 | 8,195 | 8,195 | 8,195 | 8,195 |
| I | Temperature Based Generation Derates (2) | 0 | 0 | 0 | 0 | 0 | 0 | 0 | 0 | 0 | 0 |
| J | Net ICAP External Imports | 315 | 315 | 315 | 315 | 315 | 315 | 315 | 315 | 315 | 315 |
| K | Total Resources Available (H+I+J) | 9,917 | 9,124 | 9,124 | 8,510 | 8,510 | 8,510 | 8,510 | 8,510 | 8,510 | 8,510 |
| L | Resources available after N-1-1 (E+K) | 8,937 | 8,144 | 8,144 | 7,530 | 7,530 | 7,530 | 7,530 | 7,530 | 7,530 | 7,530 |
| M | Transmission Security Margin (F+K) | 1,714 | 962 | 985 | 394 | 392 | 341 | 272 | 191 | 115 | 42 |
| N | SCRs (3), (4) | 223 | 223 | 223 | 223 | 223 | 223 | 223 | 223 | 223 | 223 |
| O | Forced Outages (2) | (744) | (599) | (599) | (515) | (515) | (515) | (515) | (515) | (515) | (515) |
| P | Adjusted Transmission Security Margin (M+N+O) (3) | 1,193 | 586 | 609 | 102 | 100 | 49 | (20) | (101) | (177) | (250) |

Notes:

1. Reflects the 2021 Gold Book existing summer capacity plus projected additions, deactivations, and de-rates. For this evaluation wind generation is assumed to have 0 MW output, solar generation is based on the ratio of solar PV nameplate capacity (2021 Gold Book Table I-9a) and solar PV peak reductions (2021 Gold Book Table I-9c). De-rates for run-of-river hydro is included as well as the Oswego Export limit for all lines in-service.
2. Includes de-rates for thermal resources.
3. Special Case Resources (SCRs) are not applied for transmission security analysis of normal operations.
4. Includes a de-rate of 205 MW for SCRs.
5. The I+K to J flows are based on N-1-1-0 analysis in the post-RNA updates utilizing the models representing summer peak 2030.

Figure 48 shows the transmission security margin for the 1-in-10 year load conditions under the assumption that the system is in an emergency condition. Insufficient transmission security margin is

observed in 2028 (Line_item N). As shown in **Figure 48**, under the 90th percentile load conditions the inclusion of additional the historical forced outage rate of thermal unit forced outages generation (line_item O) shows that the system tips in 2025 (line_item P) and remains deficient through the study period.

Figure 48: Zone J Transmission Security Margin (Summer 1-in-10 (90/10) Peak Forecast - Emergency)

| | | 90th Percentile Load Forecast | | | | | | | | | |
|------|---|-------------------------------|----------|----------|----------|----------|----------|----------|----------|----------|----------|
| Line | Item | 2022 | 2023 | 2024 | 2025 | 2026 | 2027 | 2028 | 2029 | 2030 | 2031 |
| A | Zone J Load Forecast | (11,577) | (11,534) | (11,510) | (11,486) | (11,488) | (11,541) | (11,613) | (11,697) | (11,777) | (11,853) |
| B | I+K to J | 3,904 | 3,904 | 3,904 | 3,904 | 3,904 | 3,904 | 3,904 | 3,904 | 3,904 | 3,904 |
| C | ABC PARs to J | (11) | (11) | (11) | (11) | (11) | (11) | (11) | (11) | (11) | (11) |
| D | Total J AC Import (B+C) | 3,893 | 3,893 | 3,893 | 3,893 | 3,893 | 3,893 | 3,893 | 3,893 | 3,893 | 3,893 |
| E | Loss of Source Contingency | (980) | (980) | (980) | (980) | (980) | (980) | (980) | (980) | (980) | (980) |
| F | Resource Need (A+D+E) | (8,664) | (8,621) | (8,597) | (8,573) | (8,575) | (8,628) | (8,700) | (8,784) | (8,864) | (8,940) |
| G | Resources needed after N-1-1 (A+D) | (7,684) | (7,641) | (7,617) | (7,593) | (7,595) | (7,648) | (7,720) | (7,804) | (7,884) | (7,960) |
| H | J Generation (1) | 9,602 | 8,809 | 8,809 | 8,195 | 8,195 | 8,195 | 8,195 | 8,195 | 8,195 | 8,195 |
| I | Temperature Based Generation Derates | (72) | (61) | (61) | (52) | (52) | (52) | (52) | (52) | (52) | (52) |
| J | Net ICAP External Imports | 315 | 315 | 315 | 315 | 315 | 315 | 315 | 315 | 315 | 315 |
| K | SCRs (3), (4) | 223 | 223 | 223 | 223 | 223 | 223 | 223 | 223 | 223 | 223 |
| L | Total Resources Available (H+I+J+K) | 10,069 | 9,285 | 9,285 | 8,681 | 8,681 | 8,681 | 8,681 | 8,681 | 8,681 | 8,681 |
| M | Resources available after N-1-1 (E+L) | 9,089 | 8,305 | 8,305 | 7,701 | 7,701 | 7,701 | 7,701 | 7,701 | 7,701 | 7,701 |
| N | Transmission Security Margin (F+L) | 1,405 | 664 | 688 | 108 | 106 | 53 | (19) | (103) | (183) | (259) |
| O | Forced Outages (2) | (744) | (599) | (599) | (515) | (515) | (515) | (515) | (515) | (515) | (515) |
| P | Adjusted Transmission Security Margin (N+O) | 661 | 65 | 89 | (407) | (409) | (462) | (534) | (618) | (698) | (774) |

Notes:

1. Reflects the 2021 Gold Book existing summer capacity plus projected additions, deactivations, and de-rates. For this evaluation wind generation is assumed to have 0 MW output, solar generation is based on the ratio of solar PV nameplate capacity (2021 Gold Book Table I-9a) and solar PV peak reductions (2021 Gold Book Table I-9c). De-rates for run-of-river hydro is included as well as the Oswego Export limit for all lines in-service.
2. Includes de-rates for thermal resources.
3. SCRs are not applied for transmission security analysis of normal operations, but are included for emergency operations.
4. Includes a de-rate of 205 MW for SCRs.

| | | 90th Percentile Load Forecast | | | | | | | | | |
|------|---|-------------------------------|----------|----------|----------|----------|----------|----------|----------|----------|----------|
| Line | Item | 2022 | 2023 | 2024 | 2025 | 2026 | 2027 | 2028 | 2029 | 2030 | 2031 |
| A | Zone J Load Forecast | (11,577) | (11,534) | (11,510) | (11,486) | (11,488) | (11,541) | (11,613) | (11,697) | (11,777) | (11,853) |
| B | I+K to J (5) | 3,904 | 3,904 | 3,904 | 3,904 | 3,904 | 3,904 | 3,904 | 3,904 | 3,904 | 3,904 |
| C | ABC PARs to J | (11) | (11) | (11) | (11) | (11) | (11) | (11) | (11) | (11) | (11) |
| D | Total J AC Import (B+C) | 3,893 | 3,893 | 3,893 | 3,893 | 3,893 | 3,893 | 3,893 | 3,893 | 3,893 | 3,893 |
| E | Loss of Source Contingency | (980) | (980) | (980) | (980) | (980) | (980) | (980) | (980) | (980) | (980) |
| F | Resource Need (A+D+E) | (8,664) | (8,621) | (8,597) | (8,573) | (8,575) | (8,628) | (8,700) | (8,784) | (8,864) | (8,940) |
| G | Resources needed after N-1-1 (A+D) | (7,684) | (7,641) | (7,617) | (7,593) | (7,595) | (7,648) | (7,720) | (7,804) | (7,884) | (7,960) |
| H | J Generation (1) | 9,602 | 8,809 | 8,809 | 8,195 | 8,195 | 8,195 | 8,195 | 8,195 | 8,195 | 8,195 |
| I | Temperature Based Generation Derates | (72) | (61) | (61) | (52) | (52) | (52) | (52) | (52) | (52) | (52) |
| J | Net ICAP External Imports | 315 | 315 | 315 | 315 | 315 | 315 | 315 | 315 | 315 | 315 |
| K | SCRs (3), (4) | 223 | 223 | 223 | 223 | 223 | 223 | 223 | 223 | 223 | 223 |
| L | Total Resources Available (H+I+J+K) | 10,069 | 9,285 | 9,285 | 8,681 | 8,681 | 8,681 | 8,681 | 8,681 | 8,681 | 8,681 |
| M | Resources available after N-1-1 (E+L) | 9,089 | 8,305 | 8,305 | 7,701 | 7,701 | 7,701 | 7,701 | 7,701 | 7,701 | 7,701 |
| N | Transmission Security Margin (F+L) | 1,405 | 664 | 688 | 108 | 106 | 53 | (19) | (103) | (183) | (259) |
| O | Forced Outages (2) | (744) | (599) | (599) | (515) | (515) | (515) | (515) | (515) | (515) | (515) |
| P | Adjusted Transmission Security Margin (N+O) | 661 | 65 | 89 | (407) | (409) | (462) | (534) | (618) | (698) | (774) |

Notes:

1. Reflects the 2021 Gold Book existing summer capacity plus projected additions, deactivations, and de-rates. For this evaluation wind generation is assumed to have 0 MW output, solar generation is based on the ratio of solar PV nameplate capacity (2021 Gold Book Table I-9a) and solar PV peak reductions (2021 Gold Book Table I-9c). De-rates for run-of-river hydro is included as well as the Oswego Export limit for all lines in-service.
2. Includes de-rates for thermal resources.
3. SCRs are not applied for transmission security analysis of normal operations, but are included for emergency operations.
4. Includes a de-rate of 205 MW for SCRs.
5. The I+K to J flows are based on N-1-1-0 analysis in the post-RNA updates utilizing the models representing summer peak 2030.

Under transmission security for the 1 in 100 year forecast, **Figure 49** shows that there is insufficient transmission security margin (line_item N) starting in 2025. The adjusted transmission security margin (line_item P), which includes derates for the historical forced outage rate of thermal resources generation, exacerbates the insufficiency of the transmission security margin and the system tips as early as 2023.

Figure 49: Zone J Transmission Security Margin (Summer 1-in-100 Peak Forecast - Emergency)

| 1 in 100 Forecast | | | | | | | | | | | |
|-------------------|--|----------------|----------------|----------------|----------------|----------------|----------------|----------------|----------------|----------------|----------------|
| Line | Item | 2022 | 2023 | 2024 | 2025 | 2026 | 2027 | 2028 | 2029 | 2030 | 2031 |
| A | Zone J Load Forecast | (12,068) | (12,023) | (11,998) | (11,974) | (11,976) | (12,031) | (12,106) | (12,194) | (12,276) | (12,356) |
| B | I+K to J | 3,904 | 3,904 | 3,904 | 3,904 | 3,904 | 3,904 | 3,904 | 3,904 | 3,904 | 3,904 |
| C | ABC PARs to J | (11) | (11) | (11) | (11) | (11) | (11) | (11) | (11) | (11) | (11) |
| D | Total J AC Import (B+C) | 3,893 | 3,893 | 3,893 | 3,893 | 3,893 | 3,893 | 3,893 | 3,893 | 3,893 | 3,893 |
| E | Loss of Source Contingency | (980) | (980) | (980) | (980) | (980) | (980) | (980) | (980) | (980) | (980) |
| F | Resource Need (A+D+E) | (9,155) | (9,110) | (9,085) | (9,061) | (9,063) | (9,118) | (9,193) | (9,281) | (9,363) | (9,443) |
| G | <i>Resources needed after N-1-1 (A+D)</i> | <i>(8,175)</i> | <i>(8,130)</i> | <i>(8,105)</i> | <i>(8,081)</i> | <i>(8,083)</i> | <i>(8,138)</i> | <i>(8,213)</i> | <i>(8,301)</i> | <i>(8,383)</i> | <i>(8,463)</i> |
| H | J Generation (1) | 9,602 | 8,809 | 8,809 | 8,195 | 8,195 | 8,195 | 8,195 | 8,195 | 8,195 | 8,195 |
| I | Temperature Based Generation Derates | (151) | (130) | (130) | (110) | (110) | (110) | (110) | (110) | (110) | (110) |
| J | Net ICAP External Imports | 315 | 315 | 315 | 315 | 315 | 315 | 315 | 315 | 315 | 315 |
| K | SCRs (3) | 223 | 223 | 223 | 223 | 223 | 223 | 223 | 223 | 223 | 223 |
| L | Total Resources Available (H+I+J+K) | 9,989 | 9,217 | 9,217 | 8,623 | 8,623 | 8,623 | 8,623 | 8,623 | 8,623 | 8,623 |
| M | <i>Resources available after N-1-1 (E+L)</i> | <i>9,009</i> | <i>8,237</i> | <i>8,237</i> | <i>7,643</i> | <i>7,643</i> | <i>7,643</i> | <i>7,643</i> | <i>7,643</i> | <i>7,643</i> | <i>7,643</i> |
| N | Transmission Security Margin (F+L) | 834 | 107 | 132 | (438) | (440) | (495) | (570) | (658) | (740) | (820) |
| O | Forced Outages (2) | (744) | (599) | (599) | (515) | (515) | (515) | (515) | (515) | (515) | (515) |
| P | Adjusted Transmission Security Margin (N+O) | 90 | (492) | (467) | (953) | (955) | (1,010) | (1,085) | (1,173) | (1,255) | (1,335) |

Notes:

1. Reflects the 2021 Gold Book existing summer capacity plus projected additions, deactivations, and de-rates. For this evaluation wind generation is assumed to have 0 MW output, solar generation is based on the ratio of solar PV nameplate capacity (2021 Gold Book Table I-9a) and solar PV peak reductions (2021 Gold Book Table I-9c). De-rates for run-of-river hydro is included as well as the Oswego Export limit for all lines in-service.
2. Includes de-rates for thermal resources.
3. SCRs are not applied for transmission security analysis of normal operations, but are included for emergency operations.
4. Includes a de-rate of 205 MW for SCRs.

| 1 in 100 Forecast | | | | | | | | | | | |
|-------------------|--|----------------|----------------|----------------|----------------|----------------|----------------|----------------|----------------|----------------|----------------|
| Line | Item | 2022 | 2023 | 2024 | 2025 | 2026 | 2027 | 2028 | 2029 | 2030 | 2031 |
| A | Zone J Load Forecast | (12,068) | (12,023) | (11,998) | (11,974) | (11,976) | (12,031) | (12,106) | (12,194) | (12,276) | (12,356) |
| B | I+K to J (5) | 3,904 | 3,904 | 3,904 | 3,904 | 3,904 | 3,904 | 3,904 | 3,904 | 3,904 | 3,904 |
| C | ABC PARs to J | (11) | (11) | (11) | (11) | (11) | (11) | (11) | (11) | (11) | (11) |
| D | Total J AC Import (B+C) | 3,893 | 3,893 | 3,893 | 3,893 | 3,893 | 3,893 | 3,893 | 3,893 | 3,893 | 3,893 |
| E | Loss of Source Contingency | (980) | (980) | (980) | (980) | (980) | (980) | (980) | (980) | (980) | (980) |
| F | Resource Need (A+D+E) | (9,155) | (9,110) | (9,085) | (9,061) | (9,063) | (9,118) | (9,193) | (9,281) | (9,363) | (9,443) |
| G | <i>Resources needed after N-1-1 (A+D)</i> | <i>(8,175)</i> | <i>(8,130)</i> | <i>(8,105)</i> | <i>(8,081)</i> | <i>(8,083)</i> | <i>(8,138)</i> | <i>(8,213)</i> | <i>(8,301)</i> | <i>(8,383)</i> | <i>(8,463)</i> |
| H | J Generation (1) | 9,602 | 8,809 | 8,809 | 8,195 | 8,195 | 8,195 | 8,195 | 8,195 | 8,195 | 8,195 |
| I | Temperature Based Generation Derates | (151) | (130) | (130) | (110) | (110) | (110) | (110) | (110) | (110) | (110) |
| J | Net ICAP External Imports | 315 | 315 | 315 | 315 | 315 | 315 | 315 | 315 | 315 | 315 |
| K | SCRs (3) | 223 | 223 | 223 | 223 | 223 | 223 | 223 | 223 | 223 | 223 |
| L | Total Resources Available (H+I+J+K) | 9,989 | 9,217 | 9,217 | 8,623 | 8,623 | 8,623 | 8,623 | 8,623 | 8,623 | 8,623 |
| M | <i>Resources available after N-1-1 (E+L)</i> | <i>9,009</i> | <i>8,237</i> | <i>8,237</i> | <i>7,643</i> | <i>7,643</i> | <i>7,643</i> | <i>7,643</i> | <i>7,643</i> | <i>7,643</i> | <i>7,643</i> |
| N | Transmission Security Margin (F+L) | 834 | 107 | 132 | (438) | (440) | (495) | (570) | (658) | (740) | (820) |
| O | Forced Outages (2) | (744) | (599) | (599) | (515) | (515) | (515) | (515) | (515) | (515) | (515) |
| P | Adjusted Transmission Security Margin (N+O) | 90 | (492) | (467) | (953) | (955) | (1,010) | (1,085) | (1,173) | (1,255) | (1,335) |

Notes:

1. Reflects the 2021 Gold Book existing summer capacity plus projected additions, deactivations, and de-rates. For this evaluation wind generation is assumed to have 0 MW output, solar generation is based on the ratio of solar PV nameplate capacity (2021 Gold Book Table I-9a) and solar PV peak reductions (2021 Gold Book Table I-9c). De-rates for run-of-river hydro is included as well as the Oswego Export limit for all lines in-service.
2. Includes de-rates for thermal resources.
3. SCRs are not applied for transmission security analysis of normal operations, but are included for emergency operations.
4. Includes a de-rate of 205 MW for SCRs.
5. The I+K to J flows are based on N-1-1-0 analysis in the post-RNA updates utilizing the models representing summer peak 2030.

Figure 50: Summary of Zone J Transmission Security Margin

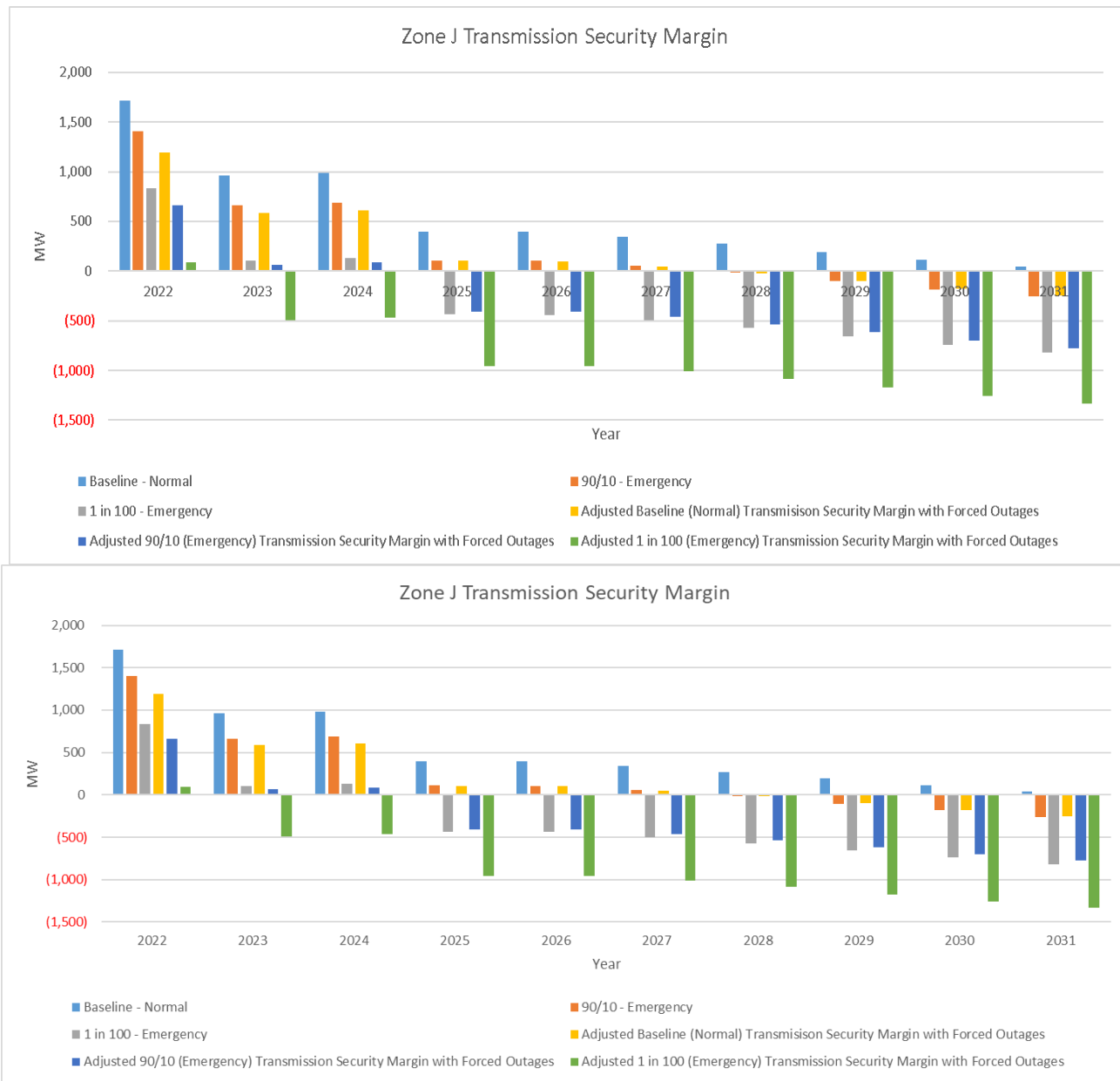

Long Island (Zone K) Tipping Points

Within the PSEG Long Island service territory, the BPTF system (primarily comprised of 138 kV transmission) is designed for N-1-1. As shown in Figure XX, the most limiting N-1-1 combination for the transmission security margin under normal conditions is the outage of Neptune HVDC (660 MW) followed by securing for the loss of Dunwoodie – Shore Road 345 kV (Y50) for all evaluated years.

Figure 51: Impact of Contingency Combination on Zone K Transmission Security Margin



As seen in **Figure 52**, the transmission security margin (line-item M) in Zone K under baseline conditions ranges from 964 MW in 2022 growing to 1,179 MW in 2031 due to a forecasted decrease in peak demand through time. Considering the baseline peakload transmission security margin, multiple outages in Zone K would be required to tip the system over its security margin, beyond the outage of Neptune.

An additional evaluation included in **Figure 52** is the impact of the historical forced outage rate of thermal generation on the transmission security margin. Also, while SCRs are not included for an evaluation of transmission security under normal transfer criteria, the impact of SCRs is accounted for in this adjusted transmission security margin. The adjusted transmission security margin (line-item P) shows that generation outages consistent with the historical forced outage rates would not result in “tipping” beyond transmission security limits, with a margin of 549 MW in 2022 growing to 829 MW in 2031. This assumes no transmission outages beyond the outage of Neptune.

Figure 52: Zone K Summer Transmission Security Margin (Summer Baseline Peak Forecast - Normal)

| | | Peak Load Forecast | | | | | | | | | |
|------|---|--------------------|---------|---------|---------|---------|---------|---------|---------|---------|---------|
| Line | Item | 2022 | 2023 | 2024 | 2025 | 2026 | 2027 | 2028 | 2029 | 2030 | 2031 |
| A | Zone K Load Forecast | (5,136) | (5,039) | (4,919) | (4,826) | (4,746) | (4,695) | (4,676) | (4,689) | (4,729) | (4,771) |
| B | I+J to K | 929 | 929 | 929 | 929 | 929 | 929 | 929 | 929 | 929 | 929 |
| C | New England Import (NNC) | 0 | 0 | 0 | 0 | 0 | 0 | 0 | 0 | 0 | 0 |
| D | Total K AC Import (B+C) | 929 | 929 | 929 | 929 | 929 | 929 | 929 | 929 | 929 | 929 |
| E | Loss of Source Contingency | (660) | (660) | (660) | (660) | (660) | (660) | (660) | (660) | (660) | (660) |
| F | Resource Need (A+D+E) | (4,867) | (4,770) | (4,650) | (4,557) | (4,477) | (4,426) | (4,407) | (4,420) | (4,460) | (4,502) |
| G | Resources needed after N-1-1 (A+D) | (4,207) | (4,110) | (3,990) | (3,897) | (3,817) | (3,766) | (3,747) | (3,760) | (3,800) | (3,842) |
| H | K Generation (1) | 5,161 | 5,024 | 5,023 | 5,023 | 5,023 | 5,023 | 5,022 | 5,022 | 5,021 | 5,021 |
| I | Temperature Based Generation Derates | 0 | 0 | 0 | 0 | 0 | 0 | 0 | 0 | 0 | 0 |
| J | Net ICAP External Imports | 660 | 660 | 660 | 660 | 660 | 660 | 660 | 660 | 660 | 660 |
| K | Total Resources Available (H+I+J) | 5,821 | 5,684 | 5,683 | 5,683 | 5,683 | 5,683 | 5,682 | 5,682 | 5,681 | 5,681 |
| L | Resources available after N-1-1 (E+K) | 5,161 | 5,024 | 5,023 | 5,023 | 5,023 | 5,023 | 5,022 | 5,022 | 5,021 | 5,021 |
| M | Transmission Security Margin (F+K) | 954 | 914 | 1,033 | 1,126 | 1,206 | 1,257 | 1,275 | 1,262 | 1,221 | 1,179 |
| N | SCRs (3), (4) | 25 | 25 | 25 | 25 | 25 | 25 | 25 | 25 | 25 | 25 |
| O | Forced Outages (2) | (430) | (375) | (375) | (375) | (375) | (375) | (375) | (375) | (375) | (375) |
| P | Adjusted Transmission Security Margin (M+N+O) (3) | 549 | 564 | 683 | 776 | 856 | 907 | 925 | 912 | 871 | 829 |

Notes:

1. Reflects the 2021 Gold Book existing summer capacity plus projected additions, deactivations, and de-rates. For this evaluation wind generation is assumed to have 0 MW output, solar generation is based on the ratio of solar PV nameplate capacity (2021 Gold Book Table I-9a) and solar PV peak reductions (2021 Gold Book Table I-9c). De-rates for run-of-river hydro is included as well as the Oswego Export limit for all lines in-service.
2. Includes de-rates for thermal resources.
3. Special Case Resources (SCRs) are not applied for transmission security analysis of normal operations.
4. Includes a de-rate of 18 MW for SCRs.

| | | Peak Load Forecast | | | | | | | | | |
|------|---|--------------------|---------|---------|---------|---------|---------|---------|---------|---------|---------|
| Line | Item | 2022 | 2023 | 2024 | 2025 | 2026 | 2027 | 2028 | 2029 | 2030 | 2031 |
| A | Zone K Load Forecast | (5,136) | (5,039) | (4,919) | (4,826) | (4,746) | (4,695) | (4,676) | (4,689) | (4,729) | (4,771) |
| B | I+J to K | 929 | 929 | 929 | 929 | 929 | 929 | 929 | 929 | 929 | 929 |
| C | New England Import (NNC) | 0 | 0 | 0 | 0 | 0 | 0 | 0 | 0 | 0 | 0 |
| D | Total K AC Import (B+C) | 929 | 929 | 929 | 929 | 929 | 929 | 929 | 929 | 929 | 929 |
| E | Loss of Source Contingency | (660) | (660) | (660) | (660) | (660) | (660) | (660) | (660) | (660) | (660) |
| F | Resource Need (A+D+E) | (4,867) | (4,770) | (4,650) | (4,557) | (4,477) | (4,426) | (4,407) | (4,420) | (4,460) | (4,502) |
| G | Resources needed after N-1-1 (A+D) | (4,207) | (4,110) | (3,990) | (3,897) | (3,817) | (3,766) | (3,747) | (3,760) | (3,800) | (3,842) |
| H | K Generation (1) | 5,161 | 5,024 | 5,023 | 5,023 | 5,023 | 5,023 | 5,022 | 5,022 | 5,021 | 5,021 |
| I | Temperature Based Generation Derates | 0 | 0 | 0 | 0 | 0 | 0 | 0 | 0 | 0 | 0 |
| J | Net ICAP External Imports | 660 | 660 | 660 | 660 | 660 | 660 | 660 | 660 | 660 | 660 |
| K | Total Resources Available (H+I+J) | 5,821 | 5,684 | 5,683 | 5,683 | 5,683 | 5,683 | 5,682 | 5,682 | 5,681 | 5,681 |
| L | Resources available after N-1-1 (E+K) | 5,161 | 5,024 | 5,023 | 5,023 | 5,023 | 5,023 | 5,022 | 5,022 | 5,021 | 5,021 |
| M | Transmission Security Margin (F+K) | 954 | 914 | 1,033 | 1,126 | 1,206 | 1,257 | 1,275 | 1,262 | 1,221 | 1,179 |
| N | SCRs (3), (4) | 25 | 25 | 25 | 25 | 25 | 25 | 25 | 25 | 25 | 25 |
| O | Forced Outages (2) | (430) | (375) | (375) | (375) | (375) | (375) | (375) | (375) | (375) | (375) |
| P | Adjusted Transmission Security Margin (M+N+O) (3) | 549 | 564 | 683 | 776 | 856 | 907 | 925 | 912 | 871 | 829 |

Notes:

1. Reflects the 2021 Gold Book existing summer capacity plus projected additions, deactivations, and de-rates. For this evaluation wind generation is assumed to have 0 MW output, solar generation is based on the ratio of solar PV nameplate capacity (2021 Gold Book Table I-9a) and solar PV peak reductions (2021 Gold Book Table I-9c). De-rates for run-of-river hydro is included as well as the Oswego Export limit for all lines in-service.
2. Includes de-rates for thermal resources.
3. Special Case Resources (SCRs) are not applied for transmission security analysis of normal operations.
4. Includes a de-rate of 18 MW for SCRs.

Figure 53 shows the transmission security margin for the 1-in-10 year load conditions (90/10) under the assumption that the system is in an emergency condition (line_item N). Under emergency conditions, higher line ratings are allowed to be utilized, fewer contingency events are secured for, and SCRs are accounted for as available resources. The limiting contingency combination under emergency conditions is the outage of Sprain Brook – East Garden City 345 kV (Y49) followed by securing for the loss of Dunwoodie – Shore Road 345 kV (Y50). An additional evaluation shown in this figure is the impact of the historical forced outage rate of Zone K **thermal** generation on the transmission security margin (line_item P). Under both conditions there is sufficient transmission security margin.

Figure 53: Zone K Summer Transmission Security Margin (Summer 1-in-10 (90/10) Peak Forecast - Emergency)

| 90th Percentile Load Forecast | | | | | | | | | | | |
|-------------------------------|--|---------|---------|---------|---------|---------|---------|---------|---------|---------|---------|
| Line | Item | 2022 | 2023 | 2024 | 2025 | 2026 | 2027 | 2028 | 2029 | 2030 | 2031 |
| A | Zone K Load Forecast | (5,530) | (5,425) | (5,296) | (5,196) | (5,110) | (5,055) | (5,035) | (5,049) | (5,092) | (5,137) |
| B | I+J to K | 887 | 887 | 887 | 887 | 887 | 887 | 887 | 887 | 887 | 887 |
| C | New England Import (NNC) | 0 | 0 | 0 | 0 | 0 | 0 | 0 | 0 | 0 | 0 |
| D | Total K AC Import (B+C) | 887 | 887 | 887 | 887 | 887 | 887 | 887 | 887 | 887 | 887 |
| E | Loss of Source Contingency | 0 | 0 | 0 | 0 | 0 | 0 | 0 | 0 | 0 | 0 |
| F | Resource Need (A+D+E) | (4,643) | (4,538) | (4,409) | (4,309) | (4,223) | (4,168) | (4,148) | (4,162) | (4,205) | (4,250) |
| G | <i>Resources needed after N-1-1 (A+D)</i> | (4,643) | (4,538) | (4,409) | (4,309) | (4,223) | (4,168) | (4,148) | (4,162) | (4,205) | (4,250) |
| H | K Generation (1) | 5,161 | 5,024 | 5,023 | 5,023 | 5,023 | 5,023 | 5,022 | 5,022 | 5,021 | 5,021 |
| I | Temperature Based Generation Derates | (38) | (36) | (36) | (36) | (36) | (36) | (36) | (36) | (36) | (36) |
| J | Net ICAP External Imports | 660 | 660 | 660 | 660 | 660 | 660 | 660 | 660 | 660 | 660 |
| K | SCRs (3), (4) | 25 | 25 | 25 | 25 | 25 | 25 | 25 | 25 | 25 | 25 |
| L | Total Resources Available (H+I+J+K) | 5,808 | 5,674 | 5,672 | 5,672 | 5,672 | 5,672 | 5,671 | 5,671 | 5,670 | 5,670 |
| M | <i>Resources available after N-1-1 (E+L)</i> | 5,808 | 5,674 | 5,672 | 5,672 | 5,672 | 5,672 | 5,671 | 5,671 | 5,670 | 5,670 |
| N | Transmission Security Margin (F+L) | 1,165 | 1,136 | 1,263 | 1,363 | 1,449 | 1,504 | 1,523 | 1,509 | 1,465 | 1,420 |
| O | Forced Outages (2) | (430) | (375) | (375) | (375) | (375) | (375) | (375) | (375) | (375) | (375) |
| P | Adjusted Transmission Security Margin (N+O) | 735 | 761 | 888 | 988 | 1,074 | 1,129 | 1,148 | 1,134 | 1,090 | 1,045 |

Notes:

1. Reflects the 2021 Gold Book existing summer capacity plus projected additions, deactivations, and de-rates. For this evaluation wind generation is assumed to have 0 MW output, solar generation is based on the ratio of solar PV nameplate capacity (2021 Gold Book Table I-9a) and solar PV peak reductions (2021 Gold Book Table I-9c). De-rates for run-of-river hydro is included as well as the Oswego Export limit for all lines in-service.
2. Includes de-rates for thermal resources.
3. SCRs are not applied for transmission security analysis of normal operations, but are included for emergency operations.
4. Includes a de-rate of 18 MW for SCRs.

For the 1-in-100 year forecast shown in **Figure 54**, sufficient transmission security margin is observed for all years assuming that the system is in an emergency condition. An additional evaluation shown in this figure is the impact of the historical forced outage rate of Zone K generation on the transmission security margin (line item P). Under both conditions there is sufficient transmission security margin. However, if a large facility such as Neptune is also lost in addition to the generator outages, there would be insufficient transmission security margin (line item P) in years 2022 through 2025.

Figure 54: Zone K Transmission Security Margin (Summer 1-in-100 Peak Forecast - Emergency)

| 1 in 100 Forecast | | | | | | | | | | | |
|-------------------|--|---------|---------|---------|---------|---------|---------|---------|---------|---------|---------|
| Line | Item | 2022 | 2023 | 2024 | 2025 | 2026 | 2027 | 2028 | 2029 | 2030 | 2031 |
| A | Zone K Load Forecast | (5,843) | (5,733) | (5,596) | (5,490) | (5,399) | (5,341) | (5,320) | (5,334) | (5,380) | (5,428) |
| B | I+J to K | 887 | 887 | 887 | 887 | 887 | 887 | 887 | 887 | 887 | 887 |
| C | New England Import (NNC) | 0 | 0 | 0 | 0 | 0 | 0 | 0 | 0 | 0 | 0 |
| D | Total K AC Import (B+C) | 887 | 887 | 887 | 887 | 887 | 887 | 887 | 887 | 887 | 887 |
| E | Loss of Source Contingency | 0 | 0 | 0 | 0 | 0 | 0 | 0 | 0 | 0 | 0 |
| F | Resource Need (A+D+E) | (4,956) | (4,846) | (4,709) | (4,603) | (4,512) | (4,454) | (4,433) | (4,447) | (4,493) | (4,541) |
| G | <i>Resources needed after N-1-1 (A+D)</i> | (4,956) | (4,846) | (4,709) | (4,603) | (4,512) | (4,454) | (4,433) | (4,447) | (4,493) | (4,541) |
| H | K Generation (1) | 5,161 | 5,024 | 5,023 | 5,023 | 5,023 | 5,023 | 5,022 | 5,022 | 5,021 | 5,021 |
| I | Temperature Based Generation Derates | (82) | (77) | (77) | (77) | (77) | (77) | (77) | (77) | (77) | (77) |
| J | Net ICAP External Imports | 660 | 660 | 660 | 660 | 660 | 660 | 660 | 660 | 660 | 660 |
| K | SCRs (3), (4) | 25 | 25 | 25 | 25 | 25 | 25 | 25 | 25 | 25 | 25 |
| L | Total Resources Available (H+I+J+K) | 5,764 | 5,632 | 5,631 | 5,631 | 5,631 | 5,631 | 5,630 | 5,630 | 5,629 | 5,629 |
| M | <i>Resources available after N-1-1 (E+L)</i> | 5,764 | 5,632 | 5,631 | 5,631 | 5,631 | 5,631 | 5,630 | 5,630 | 5,629 | 5,629 |
| N | Transmission Security Margin (F+L) | 808 | 786 | 922 | 1,028 | 1,119 | 1,177 | 1,197 | 1,183 | 1,136 | 1,088 |
| O | Forced Outages (2) | (430) | (375) | (375) | (375) | (375) | (375) | (375) | (375) | (375) | (375) |
| P | Adjusted Transmission Security Margin (N+O) | 378 | 411 | 547 | 653 | 744 | 802 | 822 | 808 | 761 | 713 |

Notes:

1. Reflects the 2021 Gold Book existing summer capacity plus projected additions, deactivations, and de-rates. For this evaluation wind generation is assumed to have 0 MW output, solar generation is based on the ratio of solar PV nameplate capacity (2021 Gold Book Table I-9a) and solar PV peak reductions (2021 Gold Book Table I-9c). De-rates for run-of-river hydro is included as well as the Oswego Export limit for all lines in-service.
2. Includes de-rates for thermal resources.
3. SCRs are not applied for transmission security analysis of normal operations, but are included for emergency operations.
4. Includes a de-rate of 18 MW for SCRs.

| 1 in 100 Forecast | | | | | | | | | | | |
|-------------------|--|---------|---------|---------|---------|---------|---------|---------|---------|---------|---------|
| Line | Item | 2022 | 2023 | 2024 | 2025 | 2026 | 2027 | 2028 | 2029 | 2030 | 2031 |
| A | Zone K Load Forecast | (5,843) | (5,733) | (5,596) | (5,490) | (5,399) | (5,341) | (5,320) | (5,334) | (5,380) | (5,428) |
| B | I+J to K | 887 | 887 | 887 | 887 | 887 | 887 | 887 | 887 | 887 | 887 |
| C | New England Import (NNC) | 0 | 0 | 0 | 0 | 0 | 0 | 0 | 0 | 0 | 0 |
| D | Total K AC Import (B+C) | 887 | 887 | 887 | 887 | 887 | 887 | 887 | 887 | 887 | 887 |
| E | Loss of Source Contingency | 0 | 0 | 0 | 0 | 0 | 0 | 0 | 0 | 0 | 0 |
| F | Resource Need (A+D+E) | (4,956) | (4,846) | (4,709) | (4,603) | (4,512) | (4,454) | (4,433) | (4,447) | (4,493) | (4,541) |
| G | <i>Resources needed after N-1-1 (A+D)</i> | (4,956) | (4,846) | (4,709) | (4,603) | (4,512) | (4,454) | (4,433) | (4,447) | (4,493) | (4,541) |
| H | K Generation (1) | 5,161 | 5,024 | 5,023 | 5,023 | 5,023 | 5,023 | 5,022 | 5,022 | 5,021 | 5,021 |
| I | Temperature Based Generation Derates | (82) | (77) | (77) | (77) | (77) | (77) | (77) | (77) | (77) | (77) |
| J | Net ICAP External Imports | 660 | 660 | 660 | 660 | 660 | 660 | 660 | 660 | 660 | 660 |
| K | SCRs (3), (4) | 25 | 25 | 25 | 25 | 25 | 25 | 25 | 25 | 25 | 25 |
| L | Total Resources Available (H+I+J+K) | 5,764 | 5,632 | 5,631 | 5,631 | 5,631 | 5,631 | 5,630 | 5,630 | 5,629 | 5,629 |
| M | <i>Resources available after N-1-1 (E+L)</i> | 5,764 | 5,632 | 5,631 | 5,631 | 5,631 | 5,631 | 5,630 | 5,630 | 5,629 | 5,629 |
| N | Transmission Security Margin (F+L) | 808 | 786 | 922 | 1,028 | 1,119 | 1,177 | 1,197 | 1,183 | 1,136 | 1,088 |
| O | Forced Outages (2) | (430) | (375) | (375) | (375) | (375) | (375) | (375) | (375) | (375) | (375) |
| P | Adjusted Transmission Security Margin (N+O) | 378 | 411 | 547 | 653 | 744 | 802 | 822 | 808 | 761 | 713 |

Notes:

1. Reflects the 2021 Gold Book existing summer capacity plus projected additions, deactivations, and de-rates. For this evaluation wind generation is assumed to have 0 MW output, solar generation is based on the ratio of solar PV nameplate capacity (2021 Gold Book Table I-9a) and solar PV peak reductions (2021 Gold Book Table I-9c). De-rates for run-of-river hydro is included as well as the Oswego Export limit for all lines in-service.
2. Includes de-rates for thermal resources.
3. SCRs are not applied for transmission security analysis of normal operations, but are included for emergency operations.
4. Includes a de-rate of 18 MW for SCRs.

Figure 55: Summary of Zone K Transmission Security Margin

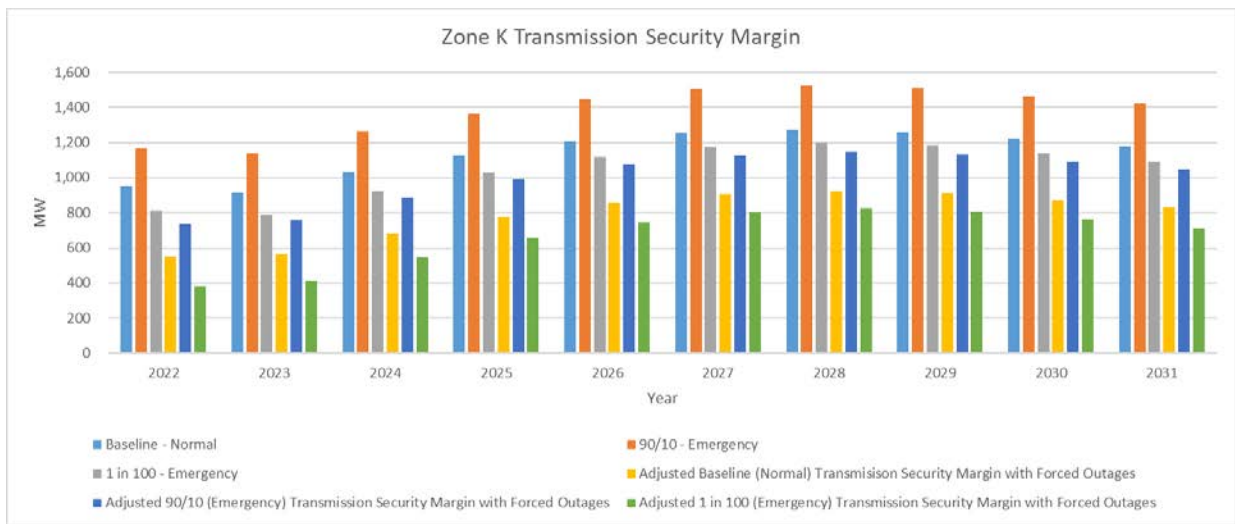
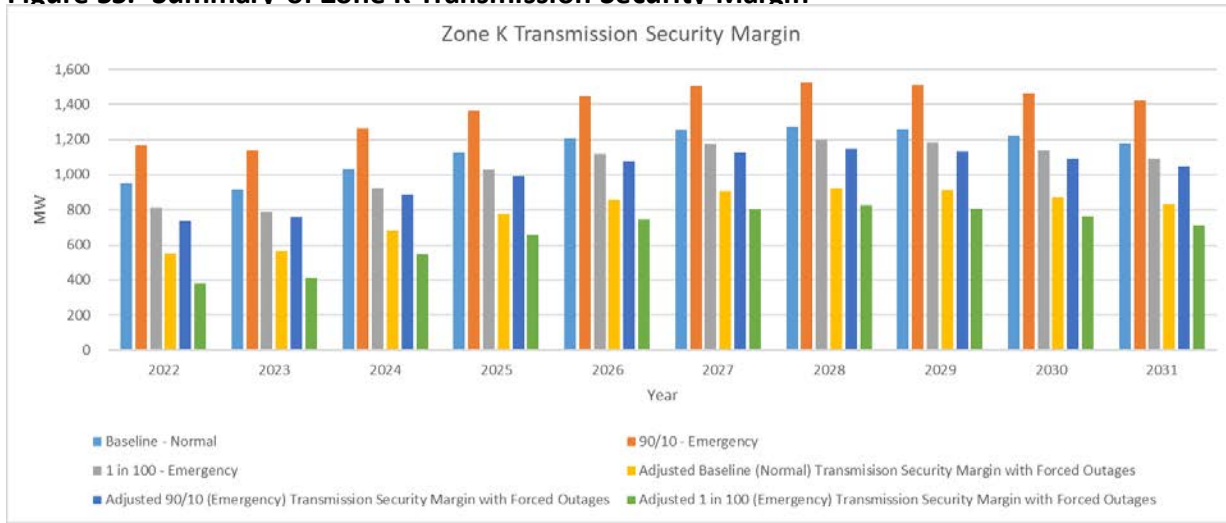

Appendix E – ~~70x30~~70 x 30 Scenario – Extended Wind Lull

One of the objectives of the Reliability Planning Process is to identify, through the development of appropriate scenarios, factors and issues that might adversely impact the reliability of the Bulk Power Transmission Facilities (BPTF). The scenarios in this CRP are focused on potential reliability issues as the New York electric system transitions to significant quantities of renewable resources that provide intermittent output to the power system.

Weather variability, which impacts the output from wind and solar resources, presents a fundamental challenge to relying exclusively on those resources to meet electricity demand, particularly during extended wind lull events. Even outside of multi-day wind lulls assessed in the study, the Climate Study's results suggest that reductions in wind output create significant reliance on dispatchable emissions free resources (DEFERs) to avoid potential loss of load events.

To continue the study efforts on this subject, the NYISO conducted additional 'wind lull' scenarios in its Reliability Planning Process. In this CRP, the NYISO conducted scenarios under which there is no wind generation output for an extended period of time, such as one week. These scenarios add to the scenarios performed under the 2020 RNA (*e.g.*, high load, 70 x 30, status quo).

Summary of the 2020 RNA 70 x 30 Scenario Major Assumptions

The [2020 RNA](#) evaluated several scenarios, including a 70 x 30 analysis. The 2020 RNA 70 x 30 Scenario modeled the same zonal renewable resource distribution as modeled in the 2019 CARIS 70 x 30 Scenario. The CARIS output was used to establish dispatch profiles accounting for generation curtailments. The nameplate capacity of the renewable resource mix is provided in **Figure 56** below.

Figure 56: Renewable Mix Assumptions for each Load Level

| 70x30 Base Load' Case (Nameplate MW) | | | | | | 70x30 'Scenario Load' Case (Nameplate MW) | | | | | |
|--------------------------------------|--------------|--------------|---------------|--------------|---------------|---|--------------|--------------|---------------|--------------|---------------|
| Zone/Type | OSW | LBW | UPV | BTM-PV | Total | Zone/Type | OSW | LBW | UPV | BTM-PV | Total |
| A | | 2,286 | 4,432 | 995 | 7,713 | A | | 1,640 | 3,162 | 995 | 5,797 |
| B | | 314 | 505 | 298 | 1,117 | B | | 207 | 361 | 298 | 866 |
| C | | 2,411 | 2,765 | 836 | 6,012 | C | | 1,765 | 1,972 | 836 | 4,573 |
| D | | 1,762 | | 76 | 1,838 | D | | 1,383 | | 76 | 1,459 |
| E | | 2,000 | 1,747 | 901 | 4,648 | E | | 1,482 | 1,247 | 901 | 3,630 |
| F | | | 3,592 | 1,131 | 4,723 | F | | | 2,563 | 1,131 | 3,694 |
| G | | | 2,032 | 961 | 2,993 | G | | | 1,450 | 961 | 2,411 |
| H | | | | 89 | 89 | H | | | | 89 | 89 |
| I | | | | 130 | 130 | I | | | | 130 | 130 |
| J | 4,320 | | | 950 | 5,270 | J | 4,320 | | | 950 | 5,270 |
| K | 1,778 | | 77 | 1,176 | 3,031 | K | 1,778 | | 77 | 1,176 | 3,031 |
| Total | 6,098 | 8,772 | 15,150 | 7,542 | 37,562 | Total | 6,098 | 6,477 | 10,832 | 7,542 | 30,949 |

Two load models from the 2019 CARIS 70 x 30 Scenario were used for the 2020 RNA 70 x 30 Scenario, both developed from the 2020 RNA 2030 Base Case, with major modifications as highlighted below:

1. **'Base Load'** represents a higher energy shape (153 TWh) and a higher peak forecast (31,303 MW): The 2002 load shape (8,760 hours) was scaled up to 2028 energy forecast from the 2019 Gold Book. The same load shape was used for all MARS load levels; and
2. **'Scenario Load'** represents a lower energy shape (136 TWh) and a lower peak forecast (25,312 MW): The CARIS-developed load shape was scaled to match CARIS 70 x 30 'Scenario Load' energy and peak demand forecast. The same load shape was used for all MARS load levels.

Figure 57: Summer Energy and Peak Demand Forecast Zonal Distribution

| 70x30 Base Load | A | B | C | D | E | F | G | H | I | J | K | NYCA |
|-----------------------------|--------------|--------------|--------------|------------|--------------|--------------|--------------|------------|--------------|---------------|--------------|---------------|
| Net Load Energy (GWh) | 14,590 | 9,695 | 15,394 | 5,337 | 7,095 | 11,312 | 9,544 | 2,807 | 5,881 | 51,749 | 19,608 | 153,012 |
| Net Load Peak (MW)* | 2,537 | 1,937 | 2,653 | 718 | 1,264 | 2,197 | 2,174 | 637 | 1,405 | 11,589 | 4,730 | 31,303 |
| + BtM-PV at Zonal Peak (MW) | 368 | 60 | 556 | 13 | 518 | 584 | 246 | 35 | 35 | 352 | 102 | 2,757 |
| Total Load Peak (MW) | 2,905 | 1,997 | 3,209 | 731 | 1,782 | 2,781 | 2,420 | 672 | 1,440 | 11,941 | 4,832 | 34,060 |

| 70x30 Scenario Load | A | B | C | D | E | F | G | H | I | J | K | NYCA |
|------------------------------------|--------------|--------------|--------------|------------|--------------|--------------|--------------|------------|--------------|--------------|--------------|---------------|
| Net Load Energy (GWh) | 13,034 | 7,757 | 12,626 | 5,101 | 5,694 | 9,654 | 7,911 | 2,848 | 5,952 | 46,354 | 19,026 | 135,958 |
| Summer Net Load Peak (MW)* | 2,112 | 1,417 | 2,171 | 651 | 1,052 | 1,988 | 1,912 | 625 | 1,385 | 9,129 | 3,914 | 25,312 |
| + BtM-PV at Summer Zonal Peak (MW) | 77 | 16 | 0 | 0 | 0 | 0 | 22 | 2 | 5 | 64 | 24 | 269 |
| Total Summer Load Peak (MW) | 2,189 | 1,433 | 2,171 | 651 | 1,052 | 1,988 | 1,934 | 627 | 1,390 | 9,193 | 3,938 | 25,581 |
| Winter Net Load Peak (MW)* | 2,234 | 1,310 | 2,264 | 740 | 1,246 | 1,934 | 1,607 | 636 | 1,065 | 7,344 | 3,841 | 23,779 |
| + BtM-PV at Winter Zonal Peak (MW) | 0 | 0 | 0 | 0 | 0 | 0 | 0 | 0 | 0 | 0 | 0 | 0 |
| Total Winter Load Peak (MW) | 2,234 | 1,310 | 2,264 | 740 | 1,246 | 1,934 | 1,607 | 636 | 1,065 | 7,344 | 3,841 | 23,779 |

Note: *Non-coincident zonal peak

Additional modeling details employed in the 2020 RNA 70 x 30 scenarios, by type:

- **Land-based wind (LBW):** Hourly dispatch profiles (MWh shapes) are applied from the CARIS simulation output, including curtailments observed in the production simulation, for each of the two load shapes. CARIS used the 2009 National Renewable Energy Laboratory (NREL) hourly data as input.
- **Off-shore Offshore wind (OSW):** Hourly dispatch profiles (MWh shapes) are applied from the CARIS simulation output, including curtailments observed in the production simulation, for each of the two load shapes. CARIS used the 2009 National Renewable Energy Laboratory (NREL) hourly data as input.
- **Utility-scale Photovoltaic (UPV):** Hourly dispatch profiles (MWh shapes) are applied from the CARIS simulation output, including curtailments observed in the production simulation, for each of the two load shapes. CARIS used the 2017 production data for existing plants and the 2006 NREL hourly data for new plants as input.
- **Behind-the-Meter PV (BtM PV):** Hourly dispatch profile (MWh shapes) are applied from the CARIS simulation output, for each of the two load shapes. The CARIS behind-the-meter solar profiles are based on hourly shapes created using the NREL's PVWatt tool.
- **External areas:** added a 1,310 MW Hydro Quebec to Zone J HVDC tie, consistent with the CARIS modeling.
- **Peakers:** All peaker units affected by DEC's Peaker Rule³⁹ were removed in 2023 and 2025 to further align with the 2019 CARIS assumptions.

Wind Lull Scenarios Assumptions

Using the 70 x 30 models developed during the 2020 RNA, and as described below, additional weekly 'wind lull' scenarios were simulated using GE MARS.

³⁹ In 2020, the New York State Department of Environmental Conservation adopted a regulation to limit nitrogen oxides (NOx) emissions from simple-cycle combustion turbines ("Peaking Units") (referred to as the "Peaker Rule"). 6 NYCRR Part 227-3. See [https://govt.westlaw.com/nycrr/Browse/Home/NewYork/NewYorkCodesRulesandRegulations?guid=I9e8759705fd311eaa71dc9fbc3ec8164&originationContext=documenttoc&transitionType=Default&contextData=\(sc.Default\)&bhcp=1](https://govt.westlaw.com/nycrr/Browse/Home/NewYork/NewYorkCodesRulesandRegulations?guid=I9e8759705fd311eaa71dc9fbc3ec8164&originationContext=documenttoc&transitionType=Default&contextData=(sc.Default)&bhcp=1). The Peaker Rule required all impacted plant owners to file compliance plans by March 2, 2020.

Resource adequacy impacts of these events are measured in terms of three reliability metrics: Loss of Load Expectation (LOLE in days/year), Loss of Load Hours (LOLH in hours/year), and Expected Unserved Energy (EUE in MWh). The assessment also determined the compensatory MW (“perfect capacity”) needed for returning the system back to its initial (pre-wind lull) LOLE, under each scenario assessed. “Perfect capacity” is capacity that is not derated (*e.g.*, due to ambient temperature or unit unavailability), not subject to energy durations limitations (*i.e.*, available for every hour of the year), and not tested for transmission security or interface impacts.

The following MARS models were used. Their assumptions reside in the 2020 RNA November Report [link]. Major assumptions are also reiterated below.

Model #1: The 70 x 30 ‘Base Load’ “at criterion” (case “67*” in the table below) cases used for the 2020 RNA scenario evaluations. These cases are brought to approximately 0.1 days/year LOLE by employing an age-based fossil removal method.

Figure 58: “70 x 30 Base Load” Case at-Criterion: Age-based Fossil Removal

| Cases (Age >=) | Total Thermal Capacity (MW) | | | | Cumulative Capacity Removed (MW) | | | | NYCA LOLE |
|-------------------|-----------------------------|--------|----------------|--------|----------------------------------|--------|----------------|-------|--------------|
| | Zone J | Zone K | Other Zones | Total | Zone J | Zone K | Other Zones | Total | |
| Total | 8,190 | 3,962 | 15,012 | 27,165 | 0 | 0 | 0 | 0 | 0.00 |
| 70 | 6,978 | 3,564 | 14,616 | 25,160 | 1,212 | 398 | 396 | 2,005 | 0.02 |
| 68 | 6,601 | 3,371 | 14,616 | 24,590 | 1,589 | 591 | 396 | 2,575 | 0.05 |
| 67* | 6,386 | 3,360 | 14,616 | 24,364 | 1,804 | 602 | 396 | 2,801 | 0.11 |
| 67 | 6,236 | 3,360 | 14,616 | 24,214 | 1,954 | 602 | 396 | 2,951 | 0.15 |

Figure 59: “70 x 30 Base Load” Case: ICAP vs UCAP

| NYCA Totals | 70x30 "CARIS Base Load" (ICAP) | 70x30 "CARIS Base Load" (UCAP) ¹ |
|--|--------------------------------------|---|
| Load (net of BtM Solar) | 31,303 | 31,303 |
| CARIS Renewable Additions (<i>offshore&land wind, utility solar</i>) | 30,020 | 7,861 |
| Total capacity in the 70x30 model before age-based removal ² | 62,837 | 38,322 |
| Total thermal capacity in the 70x30 model before age-based removal | 27,165 | 25,444 |
| Total fossil units in the 70x30 model before age-based capacity removal | 23,822 | 22,175 |
| Total nukes in the 70x30 model before age-based capacity removal | 3,343 | 3,269 |
| Age-based fossils removed to get to 0.1 LOLE ("model at criterion") ³ | 2,801 | 2,629 |
| Total capacity ("model at criterion") | 60,036 | 35,693 |
| Capacity/ Load Ratio | 191.8% | 114.0% |

| NY_J Totals | | |
|---|---------------|---------------|
| Load (net of BtM Solar) | 11,589 | 11,589 |
| Total capacity in 70x30 Case | 12,510 | 8,761 |
| Total fossil units in 70x30 model before age-based fossil removal | 8,190 | 7,602 |
| Age-based fossils removed to get to 0.1 LOLE ("model at criterion")** | 1,804 | 1,701 |
| Total capacity ("model at criterion") | 10,706 | 7,060 |
| Capacity/Load Ratio | 92.4% | 60.9% |

| NY_K Totals | | |
|---|---------------|--------------|
| Load (net of BtM Solar) | 4,730 | 4,730 |
| Total capacity in 70x30 Case | 5,782 | 4,400 |
| Total fossil units in 70x30 model before fossil removal | 3,962 | 3,745 |
| Age-based fossils removed to get to 0.1 LOLE ("model at criterion")** | 602 | 579 |
| Total capacity ("model at criterion") | 5,180 | 3,821 |
| Capacity/Load Ratio | 109.5% | 80.8% |

Notes:

1. UCAP calculation:

- For thermal units, MARS EFORD data is used.
- For renewables, UCAP is calculated based on the average output during 4 peak hours.

2. Reflects additional peakers removal in Zone K.

3. Calculated based on case “67”.

Model #2: The 70 x 30 ‘Scenario Load’ “at criterion” cases (case “38” in the table below) used for the 2020 RNA scenario evaluations. These cases are brought to approximately 0.1 days/year LOLE by employing an age-based fossil removal method.

Model #3: 70 x 30 ‘Scenario Load’ model at low LOLE: a Scenario Case with age-based removal at 0.03 LOLE, which is case “50” in the table above.

Figure 60: “7070 x 30 Scenario Load” Case at-Criterion: Age-based Fossil Removal

| Cases (Age >=) | Total Thermal Capacity (MW) | | | | Cumulative Capacity Removed (MW) | | | | NYCA LOLE |
|-------------------|-----------------------------|--------|----------------|--------|----------------------------------|--------|----------------|--------|--------------|
| | Zone J | Zone K | Other Zones | Total | Zone J | Zone K | Other Zones | Total | |
| Total | 8,190 | 3,962 | 15,012 | 27,165 | 0 | 0 | 0 | 0 | 0 |
| 50 | 4,354 | 1,541 | 11,228 | 17,124 | 3,836 | 2421 | 3784 | 10,041 | 0.03 |
| 40 | 4,354 | 1,393 | 10,247 | 15,995 | 3,836 | 2569 | 4765 | 11,170 | 0.07 |
| 39 | 4,354 | 1,349 | 10,197 | 15,901 | 3,836 | 2613 | 4815 | 11,264 | 0.09 |
| 38 | 3,563 | 1,325 | 9,935 | 14,824 | 4,627 | 2637 | 5077 | 12,341 | 0.11 |

Figure 61: “70 x 30 Scenario Load” Case at-Criterion: ICAP vs UCAP

| NYCA Totals | 70x30 "CARIS Scenario Load" (ICAP) | 70x30 "CARIS Scenario Load" (UCAP) ¹ |
|--|--|--|
| Load (net of BtM Solar) | 25,312 | 25,312 |
| CARIS Renewable Additions (<i>offshore&land wind, utility solar</i>) | 23,407 | 6,082 |
| Total capacity in the 70x30 model before age-based fossil removal ² | 56,224 | 36,543 |
| Total thermal capacity in the 70x30 model before age-based removal | 27,165 | 25,444 |
| Total fossil units in the 70x30 model before age-based capacity removal | 23,822 | 22,174 |
| Total nukes in the 70x30 model before age-based capacity removal | 3,343 | 3,269 |
| Age-based fossils removed to get to 0.1 LOLE ("model at criterion") ³ | 12,341 | 10,295 |
| Total capacity ("model at criterion") | 43,883 | 26,246 |
| Capacity/ Load Ratio | 173.4% | 103.7% |

| NY_J Totals | 70x30 "CARIS Scenario Load" (ICAP) | 70x30 "CARIS Scenario Load" (UCAP) ¹ |
|--|--|--|
| Load (net of BtM Solar) | 9,129 | 9,129 |
| Total capacity in 70x30 Case | 13,460 | 8,759 |
| Total fossil units in 70x30 model before age-based fossil removal | 8,190 | 7,602 |
| Age-based fossils removed to get to 0.1 LOLE ("model at criterion") ³ | 4,627 | 4,152 |
| Total capacity ("model at criterion") | 8,833 | 4,607 |
| Capacity/Load Ratio | 96.8% | 50.5% |

| NY_K Totals | 70x30 "CARIS Scenario Load" (ICAP) | 70x30 "CARIS Scenario Load" (UCAP) ¹ |
|--|--|--|
| Load (net of BtM Solar) | 3,914 | 3,914 |
| Total capacity in 70x30 Case | 5,782 | 4,391 |
| Total fossil units in 70x30 model before fossil removal | 3,962 | 3,745 |
| Age-based fossils removed to get to 0.1 LOLE ("model at criterion") ³ | 2,637 | 2,502 |
| Total capacity ("model at criterion") | 3,145 | 1,889 |
| Capacity/Load Ratio | 80.3% | 48.3% |

Notes:

1. UCAP calculation:

- For thermal units, MARS EFORD data is used.
- For renewables, UCAP is calculated based on the average output during peak hours.

2. Reflects additional peakers removal in Zone K.
3. Calculated based on case “38”.

Wind Lull Scenario Scope

The following types of analysis and events were simulated using each of the three MARS models described above. For each, zonal compensatory MW to bring NYCA LOLE close to the initial case was identified. The wind lull weeks assume that all land-based or ~~off-shore~~Offshore wind (not both) are completely out for the whole week (*i.e.*, seven consecutive days) and then recover for the following week.

1. Top two weeks with highest % of NYCA LOLE events:
 - a. On the top two weeks (one week at the time) with highest % of LOLE events, simulate total loss of all NYCA wind (either land-based or offshore at 0 MW for all NYCA zones) for that entire week and calculate NYCA LOLE, LOLH, and EUE.
 - b. Compute compensatory MW to bring LOLE close to the initial case.
2. Top two weeks with highest land-based wind capacity factor:
 - a. On the top two weeks (one week at the time) with highest land-based wind capacity factors simulate total loss of NYCA land-based wind (0 MW) for that entire week and calculate NYCA LOLE, LOLH, and EUE.
 - b. Compute compensatory MW to bring LOLE close to the initial case.
3. Top two weeks with highest ~~off-shore~~Offshore wind capacity factor:
 - a. On the top two weeks (one week at the time) with highest ~~off-shore~~Offshore wind capacity factors simulate total loss of NYCA ~~off-shore~~Offshore wind (0 MW) for that entire week and calculate NYCA LOLE, LOLH, and EUE.
 - b. Compute compensatory MW to bring LOLE close to the initial case.

It is important to be noted that the MARS simulations do not take into consideration potential reliability impacts due to:

- Unit commitment and dispatch, ramp rate constraints, and other production cost modeling techniques; or
- Intra-zonal constraints on the transmission system.

Wind Lull Scenario Results

The NYCA reliability indices (LOLE, LOLH, and EUE) and compensatory MW results for the loss of wind scenarios are summarized below.

LOLE is generally defined as the expected (weighted average) number of days in a given period (e.g., one study year) when at least one hour from that day, the hourly demand is projected to exceed the zonal resources (event day). Within a day, if the zonal demand exceeds the resources in at least one hour of that day, this will be counted as one event day. The criterion is that the LOLE not exceed one day in 10 years, or $LOLE < 0.1$ days/year.

LOLH is generally defined⁴⁰ as the expected number of hours per period (e.g., one study year) when a system's hourly demand is projected to exceed the zonal resources (event hour). Within an hour, if the zonal demand exceeds the resources, this will be counted as one event hour.

EUE, also referred to as loss of energy expectation (LOEE), is generally defined⁴¹ as the expected energy (MWh) per period (e.g., one study year) when the summation of the system's hourly demand is projected to exceed the zonal resources. Within an hour, if the zonal demand exceeds the resources, this deficit will be counted toward the system's EUE.

LOLE is generally defined as the expected (weighted average) number of days in a given time period (e.g., one study year) when at least one hour from that day, the hourly demand (for each of the seven load bins and per replication⁴²) is projected to exceed the zonal resources ~~capacity~~ (event day) in any of the seven load bins. Within a day, if the zonal demand exceeds the resources in at least one hour of that day ~~(which could be anywhere from hour 1 to 24),~~ this will be counted as one event day for the respective load bin. NYSRC and NPCC's LOLE criterion is that the NYCA LOLE not exceed one day in 10 years, or $LOLE < 0.1$ days/year.

LOLE does not account for the magnitude (MW) or duration (hours) of the deficit; it accounts for the number of event days in each load bin for each replication and study year. In a single MARS replication, the zonal MW hourly margins (MW surplus or deficit) are calculated for each bin using load forecast uncertainty (LFU) applied load, forced outage calculations, hourly shape values (i.e., wind, solar, run-of-river, landfill gas units), contracts and interface flows. In instances where there is a deficit in any area, EOP

⁴⁰ NYSRC's "Resource Adequacy Metrics and their Application":

<https://www.nysrc.org/PDF/Reports/Resource%20Adequacy%20Metric%20Report%20Final%204-20-2020%20164311.pdf>

⁴¹ NYSRC's "Resource Adequacy Metrics and their Application":

<https://www.nysrc.org/PDF/Reports/Resource%20Adequacy%20Metric%20Report%20Final%204-20-2020%20164311.pdf>

⁴² We currently simulate 2000 replications per study year and load level (7 load bins), for a total of 14,000 replications per study year. Weighted average is based on load bin probability, total bin event days, and total number of replications.

steps are completed until either the deficits are gone, or there are no more emergency operating procedure (EOP) steps to call. Once all of this is completed MARS calculates the reliability indices (LOLE, LOLH, LOEE) for the replication. This occurs across all load levels simultaneously: MARS lumps them all together in a weighted sum to get a single value for each replication.

LOLH is generally defined⁴³ as the expected number of hours per ~~time~~ period (e.g., one study year) when a system’s hourly demand is projected to exceed the zonal resources ~~capacity~~ (event hour) for any load bin. Within an hour, if the zonal demand exceeds the resources, this will be counted as one event hour. This metric is calculated using each hourly bin load in the given period. This occurs across all load levels simultaneously: MARS lumps them all together in a weighted sum to get a single value for each replication.

EUE, also referred to as loss of energy expectation (LOEE), is generally defined⁴⁴ as the expected energy (MWh) ~~timeper~~ period (e.g., one study year) when the summation of the system’s hourly demand is projected to exceed the zonal resources capacity for any load bin. Within an hour, if the zonal demand exceeds the resources, this deficit will be counted toward the system’s EUE. This occurs across all load levels simultaneously: MARS lumps them all together in a weighted sum to get a single value for each replication.

Loss of Land-Based Wind (LBW)

Figure 62: NYCA LOLE (days/year) for Loss of LBW during the Week with Highest LOLE Events

| No LBW during the 1st Highest NYCA Event % Week | | | | | Compensatory MW | | |
|---|---------|--------------|----------------|------------|-----------------|--------|--------|
| Model | Event % | Initial LOLE | Resultant LOLE | Delta LOLE | Zones A-I | Zone J | Zone K |
| 70x30 'Base Load' at-criterion | 34% | 0.11 | 0.11 | 0.00 | <25 | <25 | <25 |
| 70x30 'Scenario Load' at-criterion | 23% | 0.11 | 0.11 | 0.00 | <25 | <25 | <25 |
| 70x30 'Scenario Load' at-low-LOLE | 24% | 0.03 | 0.03 | 0.00 | <25 | <25 | <25 |
| No Land-Based Wind during the 2nd Highest NYCA Event % Week | | | | | Compensatory MW | | |
| Model | Event % | Initial LOLE | Resultant LOLE | Delta LOLE | Zones A-I | Zone J | Zone K |
| 70x30 'Base Load' at-criterion | 19% | 0.11 | 0.11 | 0.00 | <25 | <25 | <25 |
| 70x30 'Scenario Load' at-criterion | 18% | 0.11 | 0.11 | 0.00 | <25 | <25 | <25 |
| 70x30 'Scenario Load' at-low-LOLE | 18% | 0.03 | 0.03 | 0.00 | <25 | <25 | <25 |

⁴³ NYSRC’s “Resource Adequacy Metrics and their Application”:
[https://www.nysrc.org/PDF/Reports/Resource%20Adequacy%20Metric%20Report%20Final%204-20-2020\[6431\].pdf](https://www.nysrc.org/PDF/Reports/Resource%20Adequacy%20Metric%20Report%20Final%204-20-2020[6431].pdf)

⁴⁴ NYSRC’s “Resource Adequacy Metrics and their Application”:
[https://www.nysrc.org/PDF/Reports/Resource%20Adequacy%20Metric%20Report%20Final%204-20-2020\[6431\].pdf](https://www.nysrc.org/PDF/Reports/Resource%20Adequacy%20Metric%20Report%20Final%204-20-2020[6431].pdf)

Figure 63: NYCA LOLE (days/year) for Loss of LBW during the Week with Highest LBW Capacity Factor

| No LBW during the 1st Highest LBW Capacity Factor (CF) Week | | | | | Compensatory MW | | |
|---|--------|--------------|----------------|-------------|-----------------|--------|--------|
| Model | LBW CF | Initial LOLE | Resultant LOLE | Delta LOLE | Zones A-I | Zone J | Zone K |
| 70x30 'Base Load' at-criterion | 23% | 0.11 | 0.11 | 0.00 | <25 | <25 | <25 |
| 70x30 'Scenario Load' at-criterion | 23% | 0.11 | 0.11 | 0.00 | <25 | <25 | <25 |
| 70x30 'Scenario Load' at-low-LOLE | 23% | 0.03 | 0.03 | 0.00 | <25 | <25 | <25 |
| | | | | | | | |
| No LBW during the 2nd Highest LBW Capacity Factor Week | | | | | Compensatory MW | | |
| Model | LBW CF | Initial LOLE | Resultant LOLE | Delta LOLE | Zones A-I | Zone J | Zone K |
| 70x30 'Base Load' at-criterion | 20% | 0.11 | 0.11 | 0.00 | <25 | <25 | <25 |
| 70x30 'Scenario Load' at-criterion | 20% | 0.11 | 0.11 | 0.00 | <25 | <25 | <25 |
| 70x30 'Scenario Load' at-low-LOLE | 20% | 0.03 | 0.03 | 0.00 | <25 | <25 | <25 |

While the resource adequacy reliability criterion of 0.1 days/year established by the NYSRC and the NPCC is compared with the loss of load expectation (LOLE in days/year) calculation, currently there is no criteria for determining a reliable system based on the LOLH and EUE reliability indices.

Figure 64: NYCA LOLE (days/year), LOLH (hours/year) and EUE (MWh/year) for Loss of LBW during the Week with Highest LOLE Events

| No LBW during the 1st Highest NYCA Event % Week | | | | | | |
|---|--------------|----------------|--------------|----------------|-------------|---------------|
| Model | Initial LOLE | Resultant LOLE | Initial LOLH | Resultant LOLH | Initial EUE | Resultant EUE |
| 70x30 'Base Load' at-criterion | 0.11 | 0.11 | 0.291 | 0.291 | 85.7 | 85.7 |
| 70x30 'Scenario Load' at-criterion | 0.11 | 0.11 | 0.269 | 0.269 | 40.9 | 41.0 |
| 70x30 'Scenario Load' at-low-LOLE | 0.03 | 0.03 | 0.067 | 0.067 | 8.5 | 8.5 |
| | | | | | | |
| No Land-Based Wind during the 2nd Highest NYCA Event % Week | | | | | | |
| Model | Initial LOLE | Resultant LOLE | Initial LOLH | Resultant LOLH | Initial EUE | Resultant EUE |
| 70x30 'Base Load' at-criterion | 0.11 | 0.11 | 0.291 | 0.291 | 85.7 | 85.7 |
| 70x30 'Scenario Load' at-criterion | 0.11 | 0.11 | 0.269 | 0.272 | 40.9 | 41.8 |
| 70x30 'Scenario Load' at-low-LOLE | 0.03 | 0.03 | 0.067 | 0.069 | 8.5 | 8.9 |

Figure 65: NYCA LOLE (days/year), LOLH (hours/year) and EUE (MWh/year) for Loss of LBW during the Week with Highest LBW Capacity Factor

| No LBW during the 1st Highest LBW Capacity Factor Week | | | | | | |
|--|--------------|----------------|--------------|----------------|-------------|---------------|
| Model | Initial LOLE | Resultant LOLE | Initial LOLH | Resultant LOLH | Initial EUE | Resultant EUE |
| 70x30 'Base Load' at-criterion | 0.11 | 0.11 | 0.291 | 0.291 | 85.7 | 85.7 |
| 70x30 'Scenario Load' at-criterion | 0.11 | 0.11 | 0.269 | 0.272 | 40.9 | 41.7 |
| 70x30 'Scenario Load' at-low-LOLE | 0.03 | 0.03 | 0.067 | 0.067 | 8.5 | 8.5 |
| | | | | | | |
| No LBW during the 2nd Highest LBW Capacity Factor Week | | | | | | |
| Model | Initial LOLE | Resultant LOLE | Initial LOLH | Resultant LOLH | Initial EUE | Resultant EUE |
| 70x30 'Base Load' at-criterion | 0.11 | 0.11 | 0.291 | 0.291 | 85.7 | 85.7 |
| 70x30 'Scenario Load' at-criterion | 0.11 | 0.11 | 0.269 | 0.269 | 40.9 | 41.0 |
| 70x30 'Scenario Load' at-low-LOLE | 0.03 | 0.03 | 0.067 | 0.067 | 8.5 | 8.5 |

Loss of Land-Based Wind Observations:

Removal of all LBW generation during the studied weeks has a low to no impact on NYCA LOLE. This is largely due to the majority of the NYCA LOLE events being concentrated in the Zones J and K, whereas LBW is assumed located in the rest-of-state zones. Also, the significant amount of fossil plants in the state would likely be available during the week long wind lull. No impact on the NYCA LOLE also means that there was no need to identify compensatory MW to bring the NYCA LOLE back to the criterion level in the cases with the wind in service.

Loss of Offshore Wind (OSW)

Figure 66: NYCA LOLE (days/year) for Loss of OSW during the Week with Highest LOLE Events

| No OSW during the 1st Highest NYCA Event % Week | | | | Compensatory MW | | |
|---|--------------|----------------|------------|-----------------|--------|--------|
| Model | Initial LOLE | Resultant LOLE | Delta LOLE | Zones A-I | Zone J | Zone K |
| 70x30 'Base Load' at-criterion | 0.11 | 0.18 | 0.07 | ∞ | 200 | ∞ |
| 70x30 'Scenario Load' at-criterion | 0.11 | 0.22 | 0.11 | ∞ | ∞ | 150 |
| 70x30 'Scenario Load' at-low-LOLE | 0.03 | 0.06 | 0.03 | ∞ | ∞ | 150 |
| No OSW during the 2nd Highest NYCA Event % Week | | | | Compensatory MW | | |
| Model | Initial LOLE | Resultant LOLE | Delta LOLE | Zones A-I | Zone J | Zone K |
| 70x30 'Base Load' at-criterion | 0.11 | 0.11 | 0.01 | ∞ | 150 | ∞ |
| 70x30 'Scenario Load' at-criterion | 0.11 | 0.13 | 0.02 | ∞ | ∞ | 50 |
| 70x30 'Scenario Load' at-low-LOLE | 0.03 | 0.03 | 0.00 | ∞ | ∞ | 25 |

∞ - Either a large, or no amount of capacity added in the zone can bring NYCA LOLE back to the target LOLE

Figure 67: NYCA LOLE (days/year) for Loss of OSW during the Week with Highest OSW Wind Capacity Factor

| No OSW during the 1st Highest OSW Capacity Factor Week | | | | | Compensatory MW | | |
|--|--------|--------------|----------------|------------|-----------------|--------|--------|
| Model | OSW CF | Initial LOLE | Resultant LOLE | Delta LOLE | Zones A-I | Zone J | Zone K |
| 70x30 'Base Load' at-criterion | 41% | 0.11 | 0.26 | 0.16 | ∞ | 350 | ∞ |
| 70x30 'Scenario Load' at-criterion | 41% | 0.11 | 0.22 | 0.11 | ∞ | ∞ | 150 |
| 70x30 'Scenario Load' at-low-LOLE | 41% | 0.03 | 0.06 | 0.03 | ∞ | ∞ | 150 |
| No OSW during the 2nd Highest OSW Capacity Factor Week | | | | | Compensatory MW | | |
| Model | OSW CF | Initial LOLE | Resultant LOLE | Delta LOLE | Zones A-I | Zone J | Zone K |
| 70x30 'Base Load' at-criterion | 32% | 0.11 | 0.14 | 0.04 | ∞ | 100 | ∞ |
| 70x30 'Scenario Load' at-criterion | 32% | 0.11 | 0.47 | 0.36 | ∞ | ∞ | 400 |
| 70x30 'Scenario Load' at-low-LOLE | 32% | 0.03 | 0.16 | 0.13 | ∞ | ∞ | 350 |

∞ - Either a large, or no amount of capacity added in the zone can bring NYCA LOLE back to the target LOLE

The graphics below depict how much hourly MW of OSW is lost during the wind lull simulation weeks. This is based on the 2002 NREL zonal hourly data for OSW, as developed for the 2019 CARIS studies. For instance, the loss of 417,340 MWh of wind is simulated as lost for the wind lull simulations at highest capacity factor. The assumed nameplate capacity is 6,098 MW (in Zones J and K), and the wind is at 5,602 MW maximum output during that simulation week.

Figure 68: OSW MW Output during the Week with Highest OSW Capacity Factor

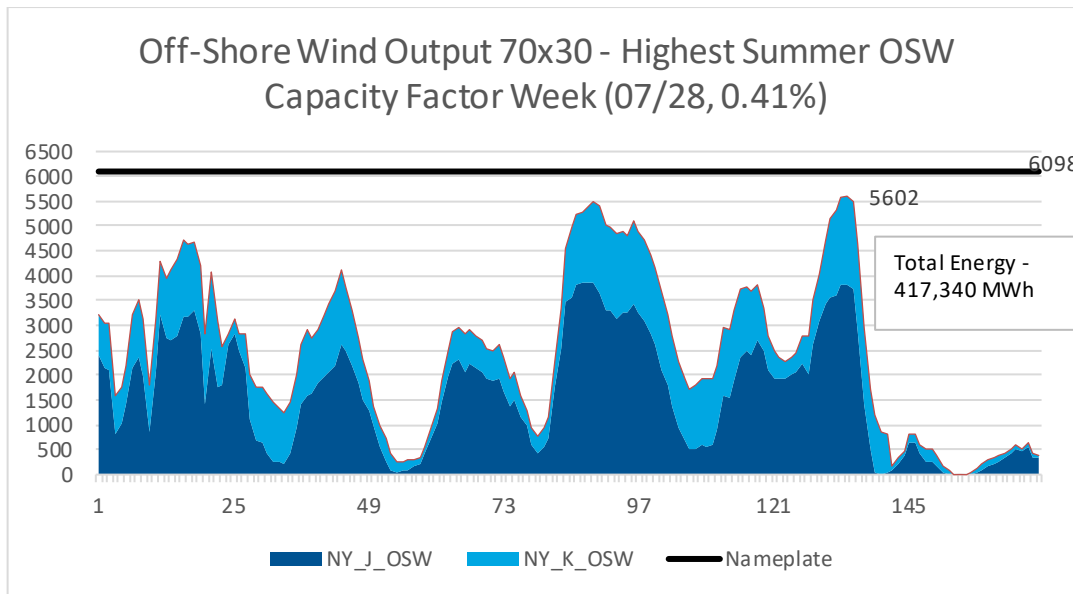

Figure 69: OSW MW Output during the Week with Highest % Events for the 70 x 30 'Base Load' Cases

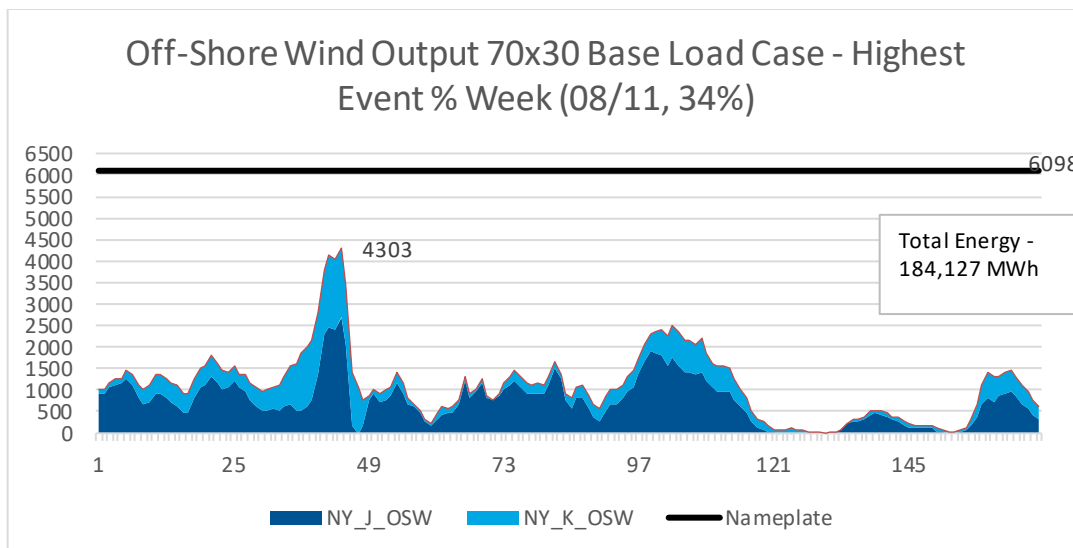
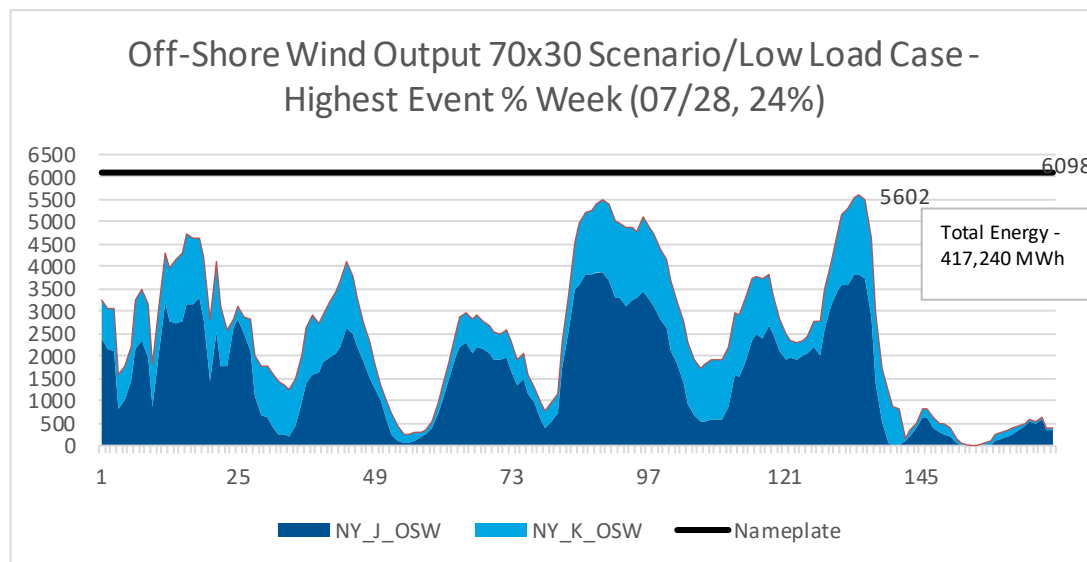

Figure 70: OSW MW Output during the Week with Highest % Events – ~~70x30~~ 70 x 30 ‘Scenario Load’ and ‘Low LOLE’ Cases



Additionally, for information purposes, the LOLH (hours/year) and EUE (MWh/year) reliability indices for each of the models and loss of wind events simulated are in the below tables.

Figure 71: NYCA LOLE (days/year), LOLH (hours/year) and EUE (MWh/year) for Loss of OSW during the Week with Highest LOLE Events

| No OSW during the 1st Highest NYCA Event % Week | | | | | | |
|---|--------------|----------------|--------------|----------------|-------------|---------------|
| Model | Initial LOLE | Resultant LOLE | Initial LOLH | Resultant LOLH | Initial EUE | Resultant EUE |
| 70x30 'Base Load' at-criterion | 0.11 | 0.18 | 0.291 | 0.547 | 85.7 | 182.8 |
| 70x30 'Scenario Load' at-criterion | 0.11 | 0.22 | 0.269 | 0.542 | 40.9 | 125.8 |
| 70x30 'Scenario Load' at-low-LOLE | 0.03 | 0.06 | 0.067 | 0.143 | 8.5 | 23.9 |
| No OSW during the 2nd Highest NYCA Event % Week | | | | | | |
| Model | Initial LOLE | Resultant LOLE | Initial LOLH | Resultant LOLH | Initial EUE | Resultant EUE |
| 70x30 'Base Load' at-criterion | 0.11 | 0.11 | 0.291 | 0.318 | 85.7 | 94.2 |
| 70x30 'Scenario Load' at-criterion | 0.11 | 0.13 | 0.269 | 0.310 | 40.9 | 46.7 |
| 70x30 'Scenario Load' at-low-LOLE | 0.03 | 0.03 | 0.067 | 0.074 | 8.5 | 9.3 |

Figure 72: NYCA LOLE (days/year), LOLE (days/year), LOLH (hours/year) and EUE (MWh/year) for Loss of OSW during the Week with Highest OSW Wind Capacity Factor

| No OSW during the 1st Highest OSW Capacity Factor Week | | | | | | |
|--|--------------|----------------|--------------|----------------|-------------|---------------|
| Model | Initial LOLE | Resultant LOLE | Initial LOLH | Resultant LOLH | Initial EUE | Resultant EUE |
| 70x30 'Base Load' at-criterion | 0.11 | 0.26 | 0.291 | 0.849 | 85.7 | 289.9 |
| 70x30 'Scenario Load' at-criterion | 0.11 | 0.22 | 0.269 | 0.542 | 40.9 | 125.8 |
| 70x30 'Scenario Load' at-low-LOLE | 0.03 | 0.06 | 0.067 | 0.143 | 8.5 | 23.9 |
| | | | | | | |
| No OSW during the 2nd Highest OSW Capacity Factor Week | | | | | | |
| Model | Initial LOLE | Resultant LOLE | Initial LOLH | Resultant LOLH | Initial EUE | Resultant EUE |
| 70x30 'Base Load' at-criterion | 0.11 | 0.14 | 0.291 | 0.414 | 85.7 | 123.6 |
| 70x30 'Scenario Load' at-criterion | 0.11 | 0.47 | 0.269 | 1.409 | 40.9 | 341.3 |
| 70x30 'Scenario Load' at-low-LOLE | 0.03 | 0.16 | 0.067 | 0.470 | 8.5 | 87.1 |

Loss of Offshore Wind Observations:

1. Removal of all ~~off-shore~~Offshore wind generation for the studied week has a substantial impact on NYCA LOLE. This is largely due to the location of the ~~off-shore~~Offshore wind in the J and K Zones, where the majority of the NYCA LOLE events occur.
2. There is a higher impact in the NYCA LOLE for the “Scenario Load” case (*i.e.*, a lower energy case), which had a higher level of MW of fossil-fueled generation removed (*i.e.*, around 12,340 MW fossil generation removed, as identified in the 2020 RNA Report) in order to bring it from a very low LOLE to the 0.1 day/year criterion (“at criterion”).
3. Annual Compensatory MW values are reducing LOLE in other times of the year, not just during the week affected by the wind lull. Hence, the “perfect capacity” values are significantly less than the amount of hourly wind lost during the week of wind lull.
4. Using yearly compensatory MW (*i.e.*, ~~”~~“perfect capacity MW” available every hour of the study year) to bring the NYCA LOLE back to the levels found in the original cases reduces resultant LOLH, but increases EUE. This is because smaller events are mitigated by the compensatory MW, but the large events that are created by the wind lull create a larger energy deficit during that week.
5. The assumption for loss of wind in these simulations was 100% loss throughout the whole week. The wind is modeled as one 8,760 hourly shape based on NREL data and 2019 CARIS output. However, the regular planning models usually contain five 8,760 hourly shapes for each wind plant modeled, with the MW data from the actual historical production. In that case, it is possible to assume a different weight for wind lull, such as 20% occurrence (instead of

100%) for one shape, with MARS randomly picking one shape for each study year replication. Applying a percentage value to the LOLE delta could be a good equivalent to simulating the random application of the same percentage chance of a wind lull occurring. For example, a 20% chance of wind lull occurring would lead to roughly an expected new LOLE equal to 20% of the change to the LOLE provided in the above tables.

Wind Lull Conclusions

With high penetration of renewable intermittent resources, the system will need dispatchable, long-duration resources to balance intermittent supply with demand especially during extended periods where the intermittent resources are not available. These types of resources will need to be significant in capacity, and have attributes such as the ability to come on-line quickly, stay on-line for as long as needed, maintain the system's balance and stability, and adapt to meet rapid, steep ramping needs.

Appendix F – ~~70x30~~70 x 30 Scenario – Dynamic Stability, Short-Circuit Ratio, and Voltage Flicker

Dynamic Stability

The steady state transmission security assessment under ~~70x30~~70 x 30 conditions was evaluated in the 2020 Reliability Needs Assessment.⁴⁵ The transmission security assessment for ~~70x30~~70 x 30 models six different output levels of intermittent renewable resources and load levels. The basis for the load and renewable resource mix is the ~~70x30~~70 x 30 ‘Base Load’ case from the 2019 CARIS ~~70x30~~70 x 30 renewable resource mix and associated load forecasts.⁴⁶ The 2019 CARIS assumptions were based on the 2019 Gold Book, and used GE MAPS for production cost simulations, and its findings are intended to provide insight of the extent to which transmission constraints may prevent the delivery of renewable energy to New York consumers. The ~~70x30~~70 x 30 scenarios evaluated in the RNA, as well as this report, are intended to supplement the 2019 CARIS ~~70x30~~70 x 30 analysis of congestion and resource curtailment by providing insights on potential reliability impacts.

Figure 73 shows the load level for each case along with the assumption for land-based wind, ~~off-shore~~Offshore wind, and solar evaluated in the transmission security assessments. **Figure 74** provides the total zonal MW capability for ~~Off-Shore~~Offshore Wind (OSW), Land-Based Wind (LBW), Utility Scale Solar (UPV), and Behind-the-Meter Solar (BTM-PV). For the solar dispatch, both the behind-the-meter and in front of the meter solar are dispatched to the same percentage. The pairings of similar load levels (*e.g.*, Cases 1 & 2, Cases 3 & 4, and Cases 5 & 6) with different levels of renewable resource penetration shows that a balance in load and generation is achievable (*i.e.*, the case was able to match load plus losses with available generation under N-0). While transmission security analysis for this assessment does not consider an 8,760-hourly type of load and generation variety, the six cases consider, within reasonable bounds, load levels that can be seen for many hours. For all cases (except Case 2), the renewable generation mix shown in Figure 6 was selected based on observations from the CARIS ~~70x30~~70 x 30 ‘Base Load’ results for similar load levels. Case 2 reflects the potential for an evening peak load assuming no MW output from wind and solar resources. The evening peak load reflects approximately 93% of the peak load observed during the day peak with no output from behind-the-meter solar. For this assessment, after peak generation removals and age-based generation removals, both 10-minute and 30-minute operating reserve levels were maintained by utilizing the remaining synchronous generation. The amount of dispatchable

⁴⁵ <https://www.nyiso.com/documents/20142/2248793/2020-RNAREport-Nov2020.pdf/>

⁴⁶ <https://www.nyiso.com/documents/20142/2226108/2019-CARIS-Phase1-Report-Final.pdf/>

resources included in the transmission security base case is approximately 24,700 MW (after age-based removals and peaker removals). The age-based fossil removals for the Base Load resource adequacy scenario in the RNA, with no energy storage resources (ESR), are also modeled in this assessment, including the removal of units that were in-service prior to January 1, 1963. This removal amounts to a total of 2,586 MW summer capability. The 2,586 MW removal is utilized in the transmission security analysis, as it is the last point of generation removal prior to observing resource adequacy LOLE violations.

Figure 73: 70 x 30 Scenario Transmission Security Case Assumptions ('Base Load' Case)

| Case # | Case Load (Net load including BtM solar reductions, MW) | Land Based Wind | Off-Shore Wind | Solar |
|--------|---|-----------------|----------------|-------------|
| | | (% of Pmax) | (% of Pmax) | (% of Pmax) |
| 1 | Day Peak Load (30,000) | 10 | 20 | 45 |
| 2 | Evening Peak Load (31,100) | 0 | 0 | 0 |
| 3 | Light Load (12,500) | 15 | 45 | 0 |
| 4 | Light Load (12,500) | 0 | 0 | 0 |
| 5 | Shoulder Load (21,500) | 0 | 0 | 40 |
| 6 | Shoulder Load (21,500) | 15 | 45 | 40 |

| Case # | Case Load (Net load including BtM solar reductions, MW) | Land Based Wind | Off-Shore Wind | Solar |
|--------|---|-----------------|----------------|-------------|
| | | (% of Pmax) | (% of Pmax) | (% of Pmax) |
| 1 | Day Peak Load (30,000) | 10 | 20 | 45 |
| 2 | Evening Peak Load (31,100) | 0 | 0 | 0 |
| 3 | Light Load (12,500) | 15 | 45 | 0 |
| 4 | Light Load (12,500) | 0 | 0 | 0 |
| 5 | Shoulder Load (21,500) | 0 | 0 | 40 |
| 6 | Shoulder Load (21,500) | 15 | 45 | 40 |

Figure 74: Capabilities (MW) of Renewable Mix Assumptions for Base Load

| Zone/Type | OSW | LBW | UPV | BTM-PV |
|--------------|--------------|--------------|---------------|--------------|
| A | - | 2,286 | 4,432 | 995 |
| B | - | 314 | 505 | 298 |
| C | - | 2,411 | 2,765 | 836 |
| D | - | 1,762 | - | 76 |
| E | - | 2,000 | 1,747 | 901 |
| F | - | - | 3,592 | 1,131 |
| G | - | - | 2,032 | 961 |
| H | - | - | - | 89 |
| I | - | - | - | 130 |
| J | 4,320 | - | - | 950 |
| K | 1,778 | - | 77 | 1,176 |
| Total | 6,098 | 8,772 | 15,150 | 7,542 |

| Zone/Type | OSW | LBW | UPV | BTM-PV |
|--------------|--------------|--------------|---------------|--------------|
| A | - | 2,286 | 4,432 | 995 |
| B | - | 314 | 505 | 298 |
| C | - | 2,411 | 2,765 | 836 |
| D | - | 1,762 | - | 76 |
| E | - | 2,000 | 1,747 | 901 |
| F | - | - | 3,592 | 1,131 |
| G | - | - | 2,032 | 961 |
| H | - | - | - | 89 |
| I | - | - | - | 130 |
| J | 4,320 | - | - | 950 |
| K | 1,778 | - | 77 | 1,176 |
| Total | 6,098 | 8,772 | 15,150 | 7,542 |

Summary of 2020 RNA Steady State Analysis Results from the 2020 RNA

The 2020 RNA documents the steady state transmission security issues focusing on the steady state thermal loading of the BPTF for N-1 and N-1-1 conditions. The thermal loading issues indicate transmission constraints that may occur with high renewable output, as well as under peak load conditions without these resources. These issues are observed in the Orange and Rockland, Con Edison, and PSEG-Long Island service territories. The thermal loading issues indicate transmission constraints that may occur with high renewable output, as well as under peak load conditions without these resources. To secure the transmission system, additional dispatchable resources would be needed. To maintain system transmission security, approximately 750 MW of dispatchable resources would be needed in addition to the 24,700 MW of dispatchable resources remaining in the model (*i.e.* after age-based removals and peakers). This assessment did not consider the potential duration of the deficiencies or the sudden loss of all ~~off-shore~~ offshore wind. Rather, contingency events for renewable resources only considered loss of resources due to electrical faults. For all cases, the NYISO locational reserves requirements were achieved by utilizing dispatchable generation.

~~70x30~~ 70x30 Dynamic Stability Transmission Security Methodology and Results

The purpose of this assessment is to identify reliability risks focusing on the system stability of the New York transmission system for N-1 and N-1-1 conditions. To capture the potential dynamics impact of renewable generators added to the model to meet the ~~70x30~~ 70x30 goals, this assessment utilizes generic

renewable models (REGCA1 and REECA1)⁴⁷ and model parameters.

For a stability simulation to be deemed stable, oscillations in angle and voltage must exhibit positive damping within ten seconds after the initiation of the disturbance. The system is unstable, if following a disturbance, the stability analysis indicates increasing angular displacement between various groups of machines or if oscillatory instability is observed.⁴⁸ For this study, the analysis considered all dynamics criteria with the exception of transient voltage response due to dynamic modeling assumptions for the renewable generators added to the model to meet the ~~70x30~~ 70x30 goals. Transient voltage response is primarily a local area issue and is sensitive to the dynamic load model as well as the dynamic characteristics of generators.

Consistent with the reliability compliance criteria, the stability analysis evaluates NERC, NPCC Directory #1, and NYSRC Reliability Rules planning design criteria stability contingencies that are expected to produce a more severe system impact on the BPTF. These contingencies include the most severe loss of reactive capability and increased impedance on the BPTF. The contingencies are modeled to simulate the removal of all elements that the protection system or other automatic controls would disconnect without operator intervention. The stability performance contingencies include the impact of successful high speed (less than one second) reclosing and unsuccessful high-speed reclosing into a fault, where high-speed reclosing is utilized. Design criteria stability N-1-1 analysis evaluates the ability of the system to meet design criteria following the occurrence of a single event and allowable system adjustments. Allowable system adjustments between the first (N-1-0) and second contingency (N-1-1) include: generator redispatch, PAR adjustments, switched shunt adjustments, transformer tap adjustments, and HVDC adjustments.

N-1 Analysis

N-1 stability analysis was performed for all six cases. Under these system conditions no N-1 dynamics criteria violations were observed.

N-1-1 Analysis

N-1-1 stability analysis was performed for Cases 1, 3, and 6 as these cases have a higher penetration of renewable resources. These cases were selected for N-1-1 analysis based on engineering judgement due to the lower amount of online system inertia inherent with higher penetrations of renewable resources.

⁴⁷ REGCA1 is a renewable energy generator/converter model and REECA1 is a generic renewable electrical control model. As generators connect to the NYCA they are required to provide all relevant modeling data (such as dynamics modeling data) as documented in the NYISO Reliability Analysis Data Manual.

⁴⁸ New York Independent System Operator, Transmission Expansion and Interconnection Manual Guideline 3-1, dated December 2020

Figure 75 below lists first event outages for the N-1-1 analysis included in this assessment. For the first event outages, the loss of key elements that may be impactful to increased penetrations of renewable resources were selected for evaluation based on engineering judgement. These events include the loss of key transmission paths (such as elements impactful to the Central East interface), the loss of large synchronous generators, and the loss of HVDC.

Figure 75: First Level Outage Cases for N-1-1 Analysis

| Outage # | Outage Description |
|----------|---------------------------------|
| 1 | Oakdale-Fraser 345 kV (32) |
| 2 | Fraser – Gilboa 345 kV (GF5-35) |
| 3 | Edic-Gordon Road 345 kV (14A) |
| 4 | Marcy-New Scotland 345 kV (18) |
| 5 | Loss of CPV Generation |
| 6 | Loss of Ravenswood 3 |
| 7 | Loss of Chateauguay HVDC Import |
| 8 | Loss of Rainey HVDC Import |

| Outage # | Outage Description |
|----------|---------------------------------|
| 1 | Oakdale-Fraser 345 kV (32) |
| 2 | Fraser – Gilboa 345 kV (GF5-35) |
| 3 | Edic-Gordon Road 345 kV (14A) |
| 4 | Marcy-New Scotland 345 kV (18) |
| 5 | Loss of CPV Generation |
| 6 | Loss of Ravenswood 3 |
| 7 | Loss of Chateauguay HVDC Import |
| 8 | Loss of Rainey HVDC Import |

Figure 4

Figure 76 below lists the second level outages for the N-1-1 analysis. These events in combination with the first level comprise the most severe event combinations.

Figure 76: N-1-1 Second Level Contingencies

| Event Name | Event Description |
|--------------|---|
| CE01_AC-SegA | Fault at Edic 345 kV with L/O Edic – Princetown (14) 345 kV |
| CE02 | Fault at Marcy 345 kV with L/O Marcy – New Scotland (UNS-18) 345 kV with reclosing |
| CE06 | Fault at Marcy 345 kV with L/O Edic – Marcy (UE1-7) 345 kV |
| CE07 | Faults at Edic 345 kV and Marcy 345 kV with L/O Marcy-Coopers Corners (UCC2-41) 345 kV and Edic-Fraser (EF24-40) 345 kV |
| CE08 | Fault at Coopers Corners 345 kV with L/O Fraser-Coopers Corners (FCC33) 345 kV and Marcy-Coopers Corners (UCC2-41) 345 kV |
| CE11 | Fault at Fraser 345 kV with L/O Fraser – Gilboa (GF-5) 345 kV and Fraser 345 kV SVC |
| CE12_AC-SegA | Fault at Princetown 345 kV with L/O Edic – Princetown (14) 345 kV with reclosing |
| CE15 | Fault at Marcy 345 kV with L/O Volney – Marcy (VU-19) 345 kV and Edic – Marcy (UE1-7) 345 kV |
| CE21OAK | Fault at Fraser 345 kV with L/O Fraser – Coopers Corners (33) 345 kV and Oakdale – Fraser (32) 345 kV |
| CE22 | Fault at Edic 345 kV with L/O Edic – Fraser (EF24-40) 345 kV |
| CE22_DCT | Fault at Edic 345 kV with L/O tower Edic – Fraser (EF24-40) 345 kV and Edic-Princetown (352) 345 kV |
| CE26_DCT | Fault at Coopers Corners 345 kV with L/O tower Marcy-Coopers Corners (UCC2-41) and Edic-Princetown (352) 345 kV |
| CE36 | Fault at Scriba 345 kV with L/O Scriba – Fitzpatrick (FS-10) 345 kV and Scriba 345/115 kV transformer T2 |
| CE99 | Fault at Scriba 345 kV with L/O Scriba – Volney (21) 345 kV and Scriba – Fitzpatrick (FS-10) 345 kV |
| ConEd08 | Fault at E. 13 th St. 138 kV with stuck breaker 4E |
| ConEd12 | Fault at Fresh Kills 138 kV with L/O Arthur Kill 2 |
| ConEd15 | Fault at Greenwood 138 kV with stuck breaker 7S |
| NE04 | Fault at Millstone 345 kV with L/O Millstone – Haddam (348) 345 kV and Millstone 3 |
| NE08 | Fault at Sandy Pond 345 kV with L/O Sandy Pond – Sandy Pond HVDC1 (3512) 345 kV |
| SA11_DCT | Fault at Edic 345 kV with L/O tower Edic-Princetown (351) 345 kV and Edic-Princetown (352) 345 kV |
| SA17_DCT | Fault at Princetown 345 kV with L/O tower Princetown-New Scotland (361) 345 kV and Princetown-New Scotland (362) 345 kV |
| ST09-VE05 | Fault at Oakdale 345 kV with L/O Oakdale – Fraser (32) 345 kV |
| ST10 | Fault at Oakdale 345 kV with L/O Oakdale – Fraser (32) 345 kV and Oakdale – Clarks Corners (36) 345 kV |
| TE03-UC03 | Fault at Sprainbrook 345 kV and L/O Sprainbrook – Millwood (W64/W99, W79/W93) 345 kV |
| TE20_UC20 | Fault at Dunwoodie 345 kV and L/O Dunwoodie – Pleasantville (W89 & W90) 345 kV |
| TE32 | Fault at New Scotland 345 kV with L/O New Scotland 77 345 kV bus |
| TE33 | Fault at New Scotland 345 kV with L/O New Scotland 99 345 kV bus |
| UC11 | Fault at Sprainbrook 345 kV and L/O Sprainbrook – Tremont (X28) 345 kV and Buchanan – Sprainbrook (W93/W79) 345 kV |
| UC25A | Fault at Ravenswood 3 345 kV and L/O Ravenswood 3 |
| UC25B | Fault at Rainey 345 kV and L/O 60L 345 kV circuit |
| VE02 | Fault at Clay 345 kV with L/O Clay – Pannell (PC-2) 345 kV and Clay – Edic (2-15) 345 kV |
| VE07 | Fault at Clay 345 kV with L/O Clay – Volney (6) 345 kV |

For the evaluated cases and contingency combinations, the N-1-1 stability analysis indicated no stability issues for any of the simulations.

Sudden Loss of ~~Off-Shore~~Offshore Wind

The purpose of this assessment is to evaluate the dynamic system response for the sudden loss of OSW. As shown in **Figure 77**, for the ~~70x30~~70 x 30 analysis, a total amount of OSW of 6,098 MW was interconnected to the NYCA system and was split between New York City (4,320 MW in Zone J) and Long Island (1,778 MW in Zone K). The evaluation of the sudden loss of ~~off-shore~~Offshore wind is not predicated on an electrical fault. Rather this condition is more plausible under weather related conditions.

In order to evaluate the impact of the sudden loss of all OSW, three scenarios were considered for the analysis: Peak Load (Case 1), Light Load (Case 3) and Shoulder Load (Case 6). The percentage of dispatch of OSW for each case is shown in Figure 6. For each case, the dynamic response of the system was evaluated under N-1 conditions and N-1-1, with the first level contingency being the loss of Sprain Brook – East Garden City 345 kV (Y49), and the second level contingency being the loss of OSW.

N-1 & N-1-1 Analysis

Under the conditions shown in **Figure 77** (Cases 1, 3, and 6), in all cases the sudden loss of OSW shows a stable system response under N-1 and N-1-1. As can be seen in Figure 10 (which provides an example of the changing interface flows under light load conditions in response to the event), to account for the loss of OSW the generators from the Eastern Interconnection provide MW output in respond to the event.

Figure 77: Light Load Interface Flows for the Loss of ~~Off Shore~~Offshore Wind (Base Output)

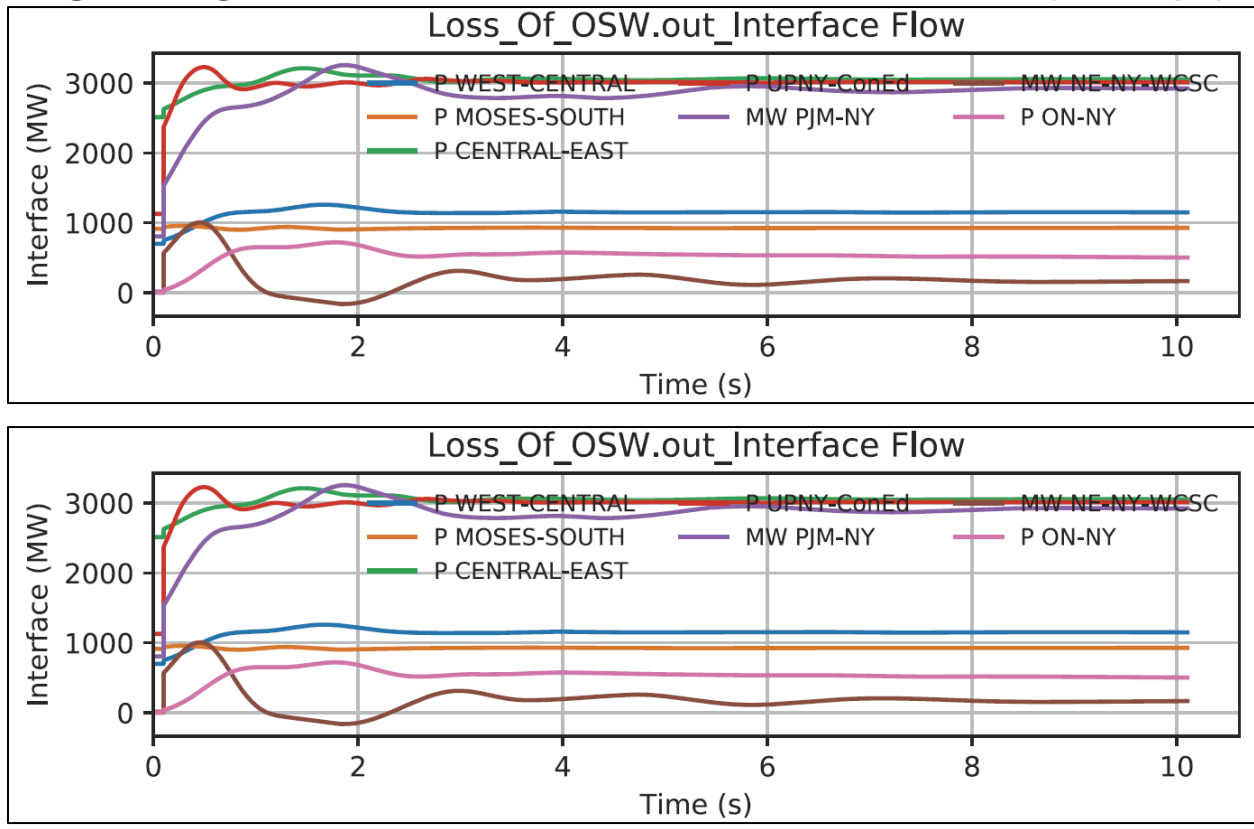

N-1 & N-1-1 Analysis (~~Off Shore~~Offshore Wind at Maximum Output)

As depicted in [Figure 6](#), [Figure 78](#), the N-1 and N-1-1 analyses under base OSW output conditions showed a stable system response. Therefore, further investigation was performed to evaluate the dynamic response of the system with OSW at maximum output. To create the condition of full OSW output, the output of fossil-based generation in New York City and Long Island was reduced. These dispatch adjustments result in N-0 thermal violations and PARs hitting angle limits. For this analysis these issues were ignored.

With OSW at full output, in all cases the sudden loss of OSW also shows a stable system response. However, as shown in Figure 11 the amount of MW flows across the NYCA interfaces has significantly increased as compared to the OSW base output conditions. There is also a noticeable degradation in the frequency response of the system when comparing the conditions shown in [Figure 6-Figure 78](#) as compared to the condition with OSW at maximum capability.

Figure 78: Light Load interface Flows for the Loss of Offshore Wind (Maximum Output)

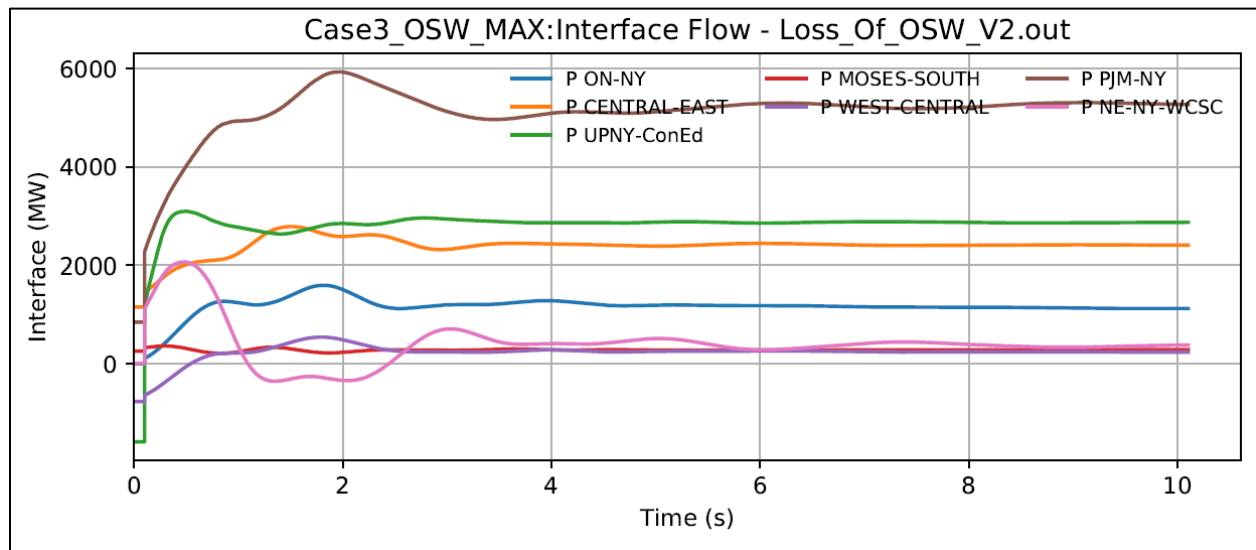
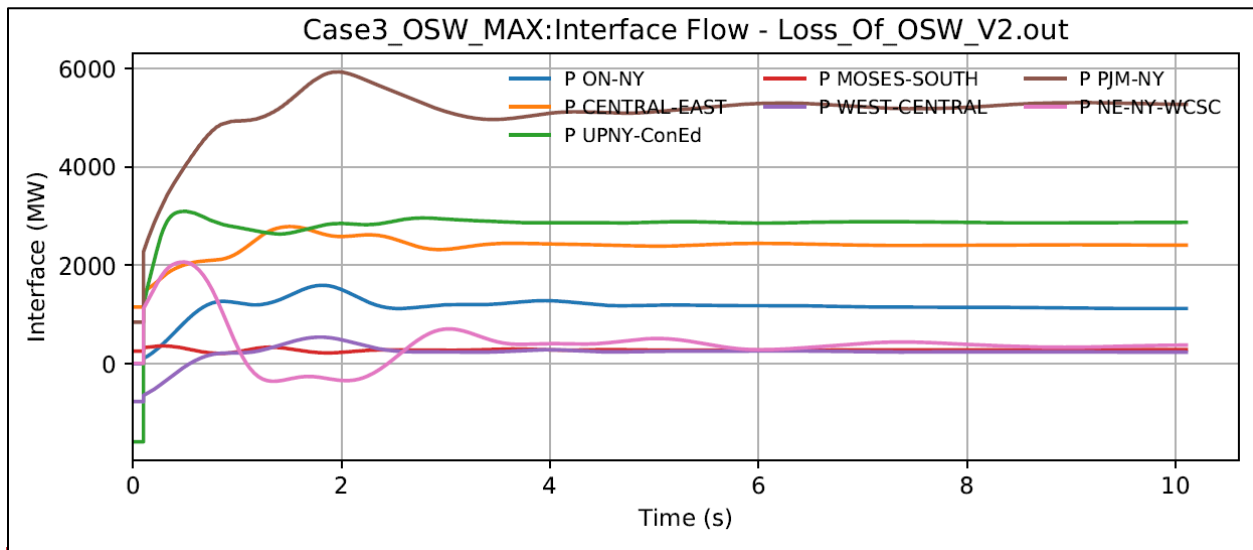

System Frequency Response for the Sudden Loss of ~~Off Shore~~Offshore Wind

Background on Frequency Response

Maintaining system frequency within appropriate bounds is an essential measure to the reliable

operation of the system.⁴⁹ At the most basic level, frequency is maintained at 60 Hz when load and generation on the system is perfectly balanced. For normal state operation, the frequency of the system is not less than 59.95 Hz or greater than 60.05 Hz.⁵⁰ Additionally, it is critical to keep the frequency response above the Under-Frequency Load Shedding (UFLS) thresholds⁵¹ so that load is not tripped.⁵²

Figure 79: Frequency Response Characteristics⁵³

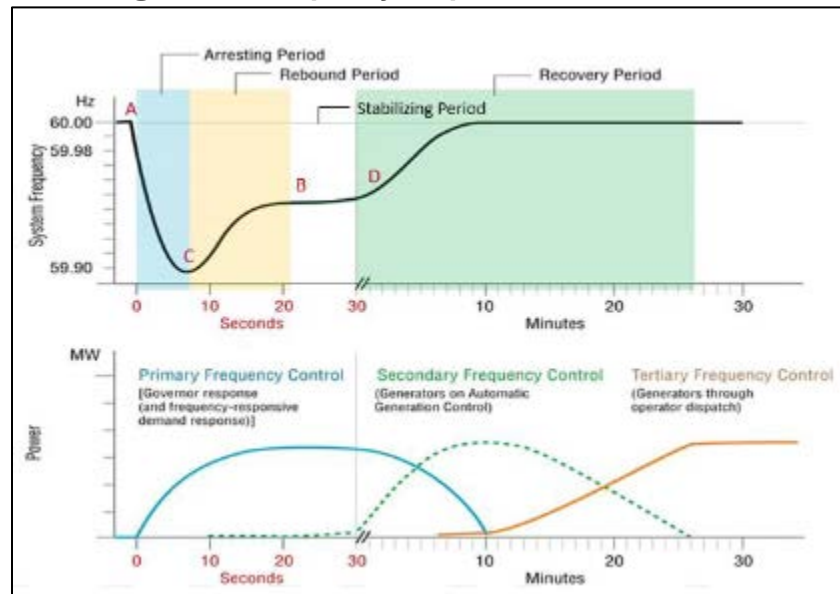

Upon loss of a large generation facility, the frequency response on the system will immediately fall, requiring a fast response to slow the rate of frequency decline and restore the system back to normal conditions. A visual description of the characteristics of frequency response is provided in [Figure 12-Figure 79](#). Point “A” in Figure 12 is the pre-disturbance frequency (at 60 Hz). The period between the time of the disturbance and the lowest frequency at point “C” (or frequency nadir) is called the arresting period (shown in blue). The nadir point shown in Figure 12 is 59.9 Hz. As rotating machines slow down (shown as a frequency decline) the generator governors sense this change in speed and act to increase the speed of the generator.⁵⁴ In order to arrest the frequency decline the governor response must offset the power deficit and replace the balancing power that had extracted inertial energy from the rotating machines of the interconnection. When the balance of power is re-established (called the “nadir”), primary response

⁴⁹ North American Electric Reliability Corporation, [Essential Reliability Services Whitepaper on Sufficiency Guidelines](#), dated December 2016.

⁵⁰ New York Independent System Operator, Transmission and Dispatch Operations Manual (Manual 12), dated March 2021.

⁵¹ Under-Frequency Load Shedding is an extreme action taken to arrest declining frequency, assist recovery of frequency following under-frequency events and provide last resort system preservation measures. See NERC Standards PRC-006 and PRC-006-NPCC.

⁵² For New York this is 59.5 Hz. See North American Electric Reliability Corporation Reliability Standard PRC-006-NPCC-2.

⁵³ North American Electric Reliability Corporation, [Primary Frequency Control Reliability Guideline](#), dated May 2019.

⁵⁴ North American Electric Reliability Corporation, [The Reliability Role of Frequency Response](#), dated October 30, 2012.

resources continue to provide additional power to the system.

Primary frequency control (or primary frequency response) is the response of generation and load to arrest local changes in frequency. This state of frequency response is automatic and begins moments after an event, such as loss of generation, occurs on the system. The initial rate at which the frequency declines depends on the amount of inertial response of the system at the time of the event. The inertial response depends on the available kinetic energy provided by rotating machines, such as synchronous generation and load, as well as governor response.⁵⁵ Inertia constants (H) are provided for individual machines, but can also be calculated for an equivalent system-wide H (or Heq). As shown in the equation below, the equivalent system inertia is ratio of Total Inertia of the System (sum of the product of Base MVA and Inertia Constant for each generator) to Total MVA Base of the System (sum of the Base MVA for each generator). Typical inertia constants for different types of generators is shown in **Figure 13** **Figure 80**.⁵⁶

$$H_{eq} = \frac{\sum_i^n H_i * MBASE_i}{\sum_i^n MBASE_i}$$

Figure 80: Typical Inertia Constant (H) Range

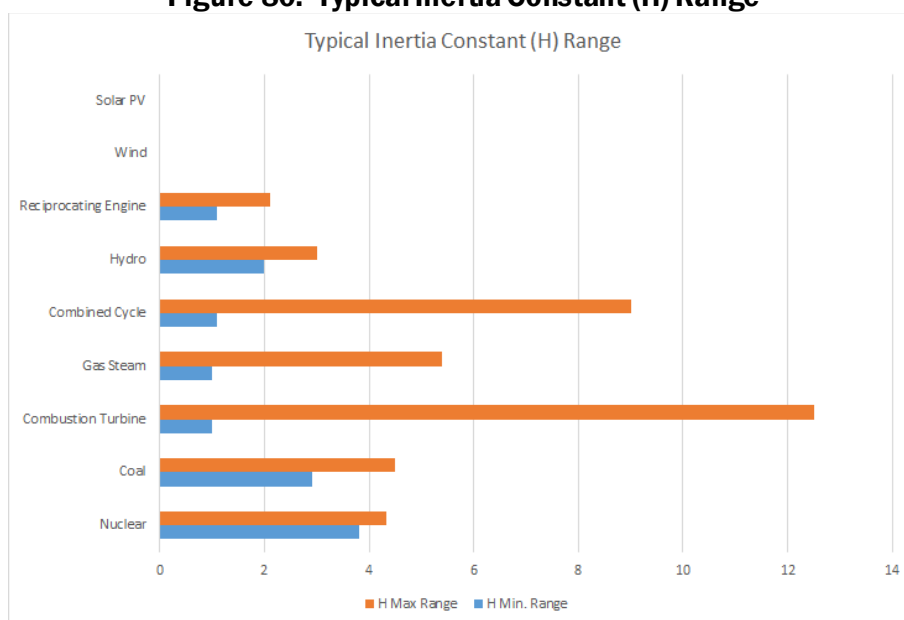

The behavior of the frequency through the rebound, stabilizing, and recovery periods depends on the behavior of primary and secondary frequency control action as well as other system characteristics, such as the behavior of load, and bus voltages. The frequency behavior shown in **Figure 12** **Figure 79** between

⁵⁵ A machine’s inertia constant H is defined as the kinetic energy divided by the machine’s rating capacity. The H constant is the time in units of seconds that it would take to deliver all of its stored kinetic energy to the power grid assuming that it is producing at rated power and speed.

⁵⁶ ERCOT, Inertia: Basic Concepts and Impacts on the ERCOT Grid, dated 2018. http://www.ercot.com/content/wcm/key_documents_lists/141324/Inertia_Basic_Concepts_Impacts_On_ERCOT_v0.pdf

points “C” and “B” is the rebound period. The frequency during the rebound period is primarily driven by the governor response of generators. Governor response is primarily driven by its droop settings and deadband. The droop setting of a generator is defined by the frequency change that is necessary to cause the generator to operate from no output to full output. For example, a three percent droop characteristic means that a three percent⁹ change in frequency causes a generator to move from full output to no output and vice versa. Deadband is the amount of frequency change that a generator must see before the governor will respond. NERC recommends deadband settings should not exceed ± 36 mHz and droop settings of no more than five percent.

The overall responsiveness of a generator during the rebound period also depends on other plant control factors. For example, the early withdrawal of primary frequency response by generators returning to their original basepoints (i.e., generators that have a squelched governor response) will slow the frequency recovery. According to Eastern Interconnection Reliability Assessment Group’s (ERAG) Multi-Regional Modeling Working Group (MMWG) Procedure Manual, a generator’s governor response is assigned one of the three classifications:

Full Responsive: The generator is sensitive to system frequency and will respond according to the change in system frequency based on the model settings.

Squelched: The generator will respond to the change in system frequency but will return to its initialized value after 10-20 seconds due to load controller action.

Non-Responsive: The generator power output changes minimally for change in system frequency.

The importance of primary frequency response (PFR) is shown in ~~Figure 14~~**Figure 81**. If sufficient sustained PFR is not available (i.e., a large portion of the system has a squelched or non-responsive governor response), although the frequency begins to recover, ultimately the frequency will collapse due to insufficient resources. FERC Order No. 842 requires all “newly interconnecting large and small generating facilities, both synchronous and non-synchronous, to install, maintain, and operate equipment capable of providing PFR as a condition of interconnection.”⁵⁷

⁵⁷ ~~<https://www.ferc.gov/sites/default/files/2020-06/Order-842.pdf>~~ <https://www.ferc.gov/sites/default/files/2020-06/Order-842.pdf>; <https://www.ferc.gov/sites/default/files/2020-06/Order-842.pdf>

Figure 81: Effect of Primary Frequency Response on System Frequency⁵⁸

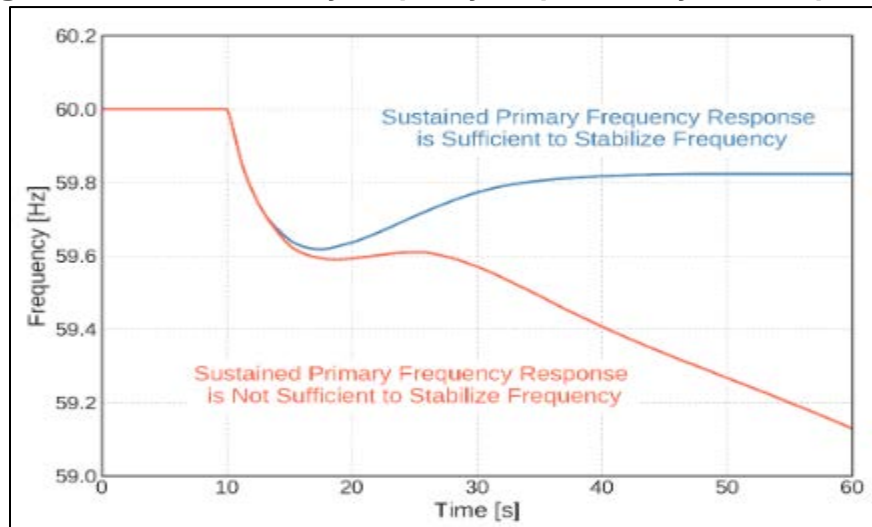

As shown in **Figure 79**, the stabilizing period is between points “B” and “D”. Frequency is stabilized at a value lower than the original scheduled frequency due to droop control characteristics. Finally, the frequency is restored back to 60 Hz during the recovery period by means of automatic generation control and other manual actions directed by system operators.

As the penetration of renewable generation increases and to the extent that these resources replace the synchronous generation across the system, the system inertia will reduce and the Rate of Change of Frequency (ROCOF) will increase.⁵⁹ Some key system characteristics that affect the ROCOF include; (i) the overall system inertia from synchronous machines and loads, (ii) speed and magnitude of energy injection response, (iii) speed and magnitude of load tripping due to frequency change, and (iv) magnitude of the contingency, including loss of source or load and its corresponding impact in system losses.

In general, as ROCOF increases, fast frequency response to arrest the ROCOF and deeper frequency nadir may be needed to avoid triggering of UFLS.⁶⁰ Fast frequency response (FFR) **Error! Bookmark not defined.** is power injected into or absorbed from the grid in response to change in the frequency during the arresting phase to improve frequency nadir and initial ROCOF. FFR can be provided by synchronous machine inertial response, governor response of synchronous machines, additional power from rotating wind turbines, and fast responding batteries and solar PV.

The FFR will be part of primary frequency response of the system and can be coordinated with the synchronous inertial response and PFR to sustain the overall frequency response of the system. As shown

⁵⁸ North American Electric Reliability Corporation, [Primary Frequency Control Reliability Guideline](#), dated May 2019

⁵⁹ ROCOF is a measure of how quickly the frequency changes following sudden imbalance between generation and load.

⁶⁰ North American Electric Reliability Corporation, [Fast Frequency Response Concepts and BPS Reliability Needs](#), dated March 2020.

in **Figure 82**, immediately after an event such as loss of large source of generation, the system indicates a non-sustained frequency response (arresting period) as the synchronous inertial response of the system along with FFR and PFR arrest the decline in the frequency. Once the nadir is established, the system indicates a sustained frequency response (rebound period) as FFR and PFR maintain change in power injection into the system until new balance of generation, load and frequency is achieved. Once the stable frequency response is achieved, the secondary frequency controls will return the system to the nominal frequency.

Figure 82: Simultaneous Contributions of Inertia Response, FFR, and PFR Error! Bookmark not defined.

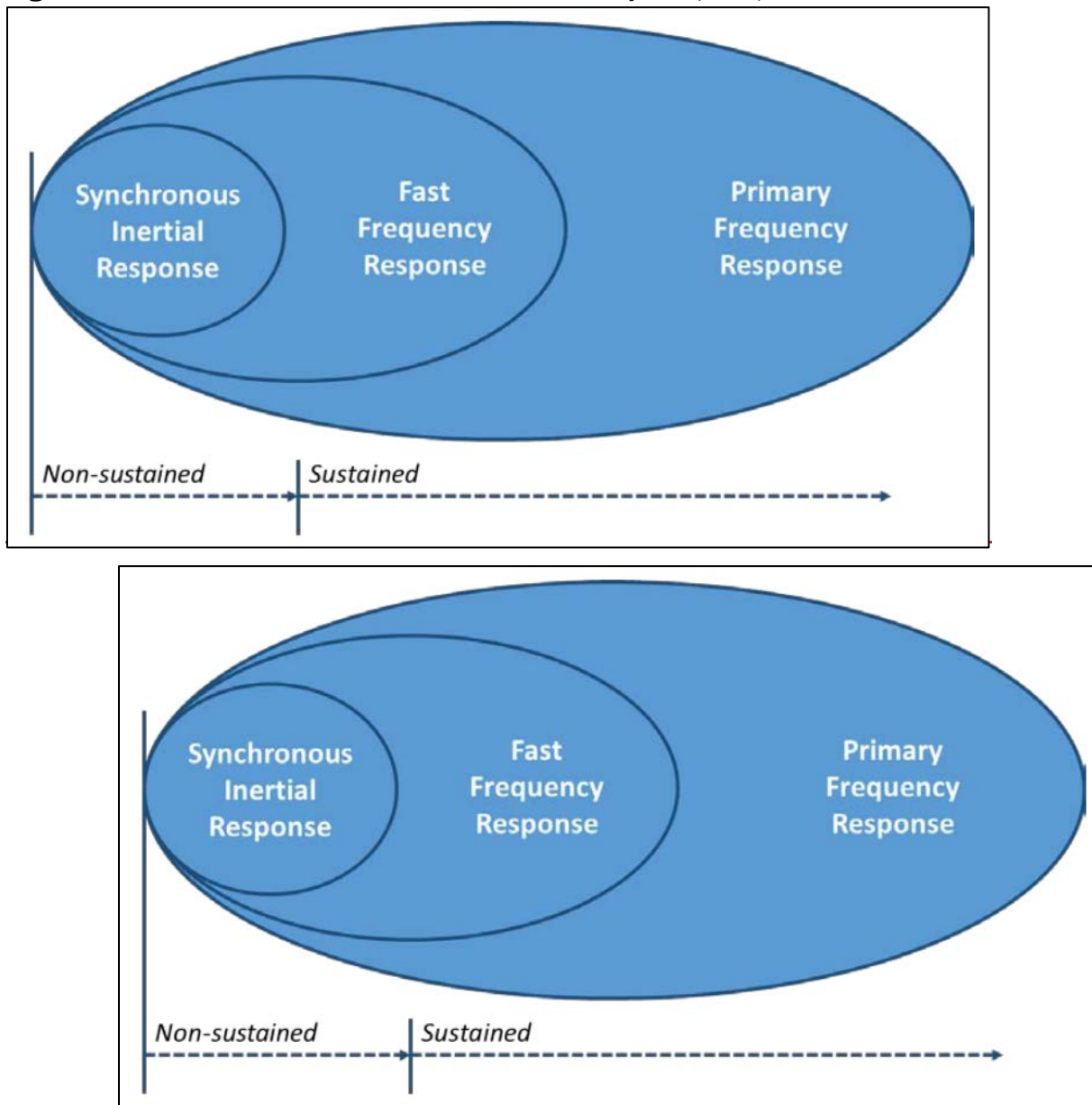

The FFR from different technologies can be available under non-sustained and sustained frequency

response phases. For the system with large synchronous inertia will have low ROCOF and a separate FFR than the PFR may not be needed. However, as the system inertia reduces, synchronous inertial response can reach a threshold at which the non-sustained frequency response can trigger UFLS actions. Thus, in order to compensate for the reduced synchronous inertial response in the system FFR can be introduced as a part of the PFR to improve the overall frequency response of the system.

As new interconnecting renewable facilities will be capable of providing frequency response, FFR from these inverter-based resources (IBR) can be an option to improve the ROCOF and frequency nadir. As shown by NERC in [Figure 16](#) **Figure 83**, IBR can provide FFR under different frequency control delay settings to improve the frequency response. The blue and purple curves are frequency response of a system with all synchronous generation with a standard delay of 100 milliseconds and a delay of 1 second respectively. The red, green and orange curves are frequency responses of the same system with 80% of the synchronous generators replaced by same sized renewable generators under different delay settings.

Figure 83: FFR Response from Inverter Based Resources Error! Bookmark not defined.

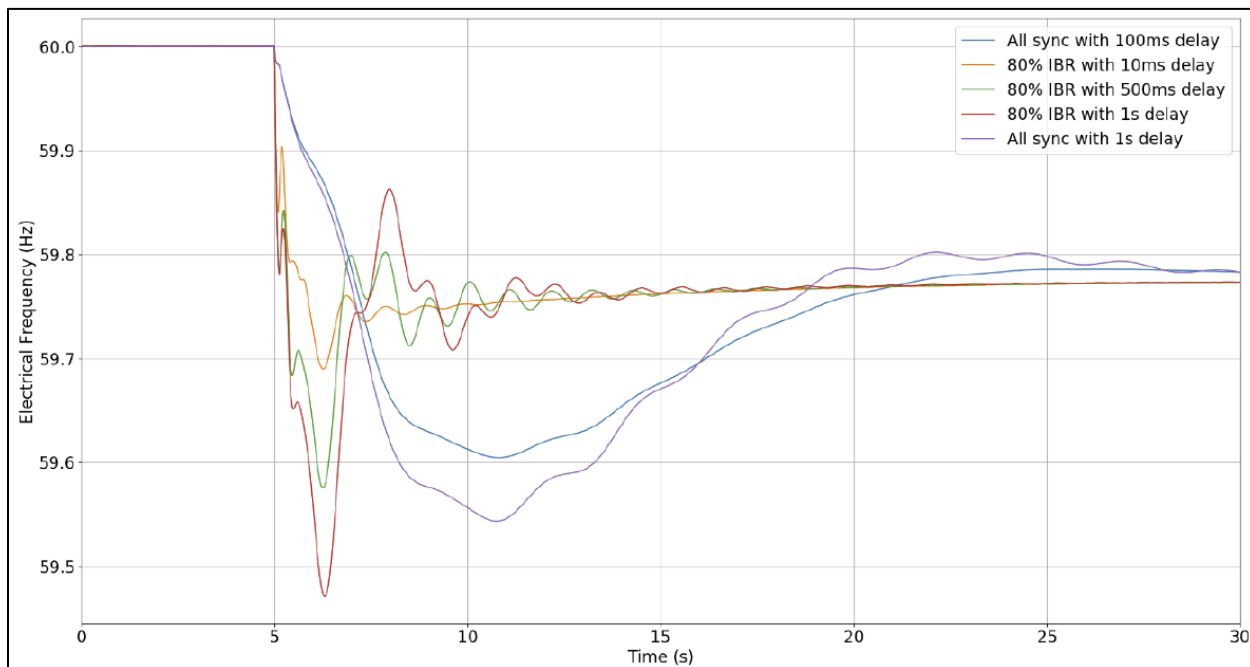

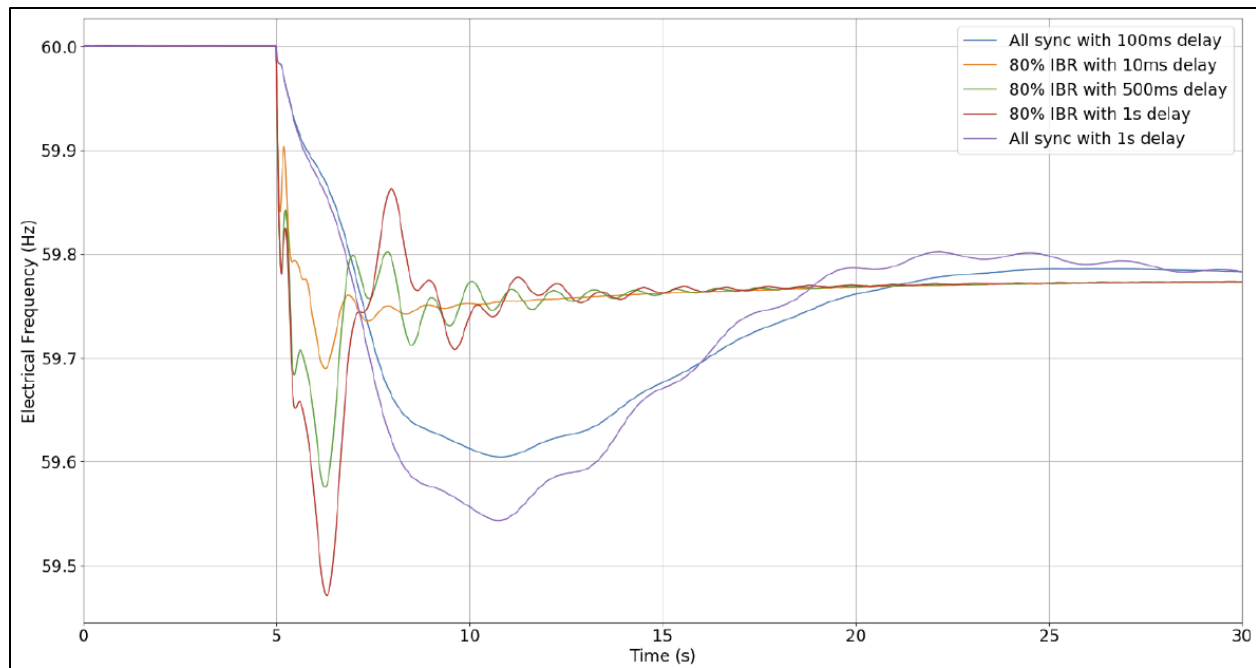

NYCA Frequency Response for the Loss of ~~Off Shore~~Offshore Wind

To evaluate the frequency response of the system, the sudden loss of OSW generation is simulated under the conditions shown in Figure 6. This simulation includes the loss of OSW as an N-1 event as well as a second level contingency under N-1-1 conditions, with the first contingency as loss of the Y49 cable.

~~Figure XX~~ **Figure 84** shows the system frequency response and NYCA generation response in Case 1 (peak) conditions for the loss of OSW event. Figure 18 provides a summary of several important characteristics of the system frequency response. For this report all frequency response plots are from the Farragut 345 kV bus. The generation MW amounts are the total NYCA generation dispatch through the simulation.

Figure 84: System Frequency Response and NYCA Generation Response for the Loss of Off-Shore Wind - Case 1

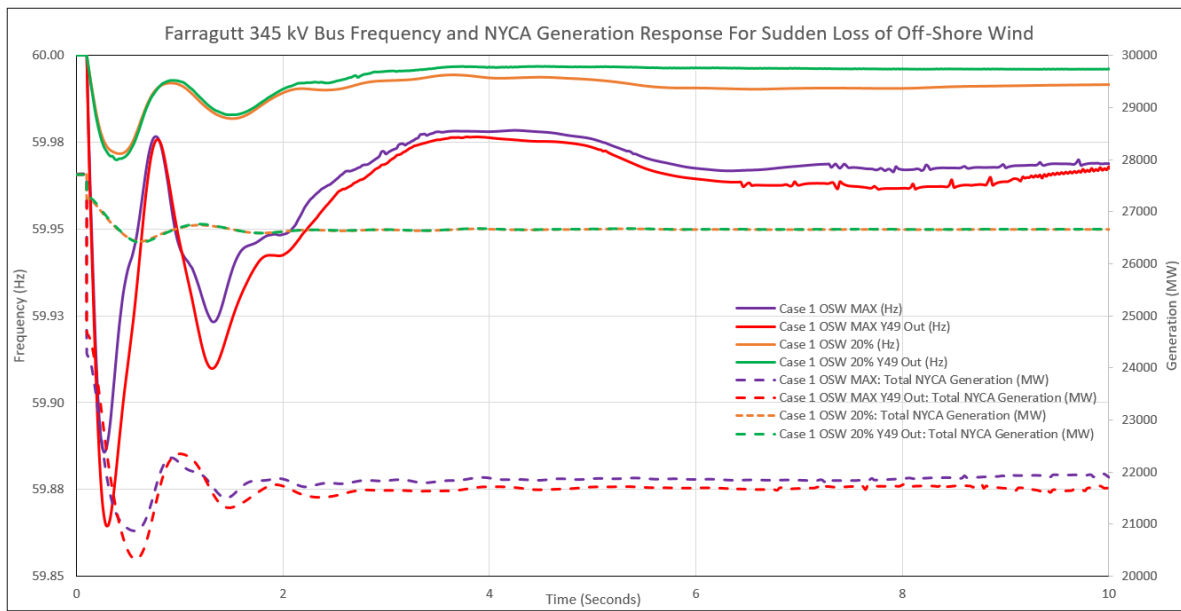
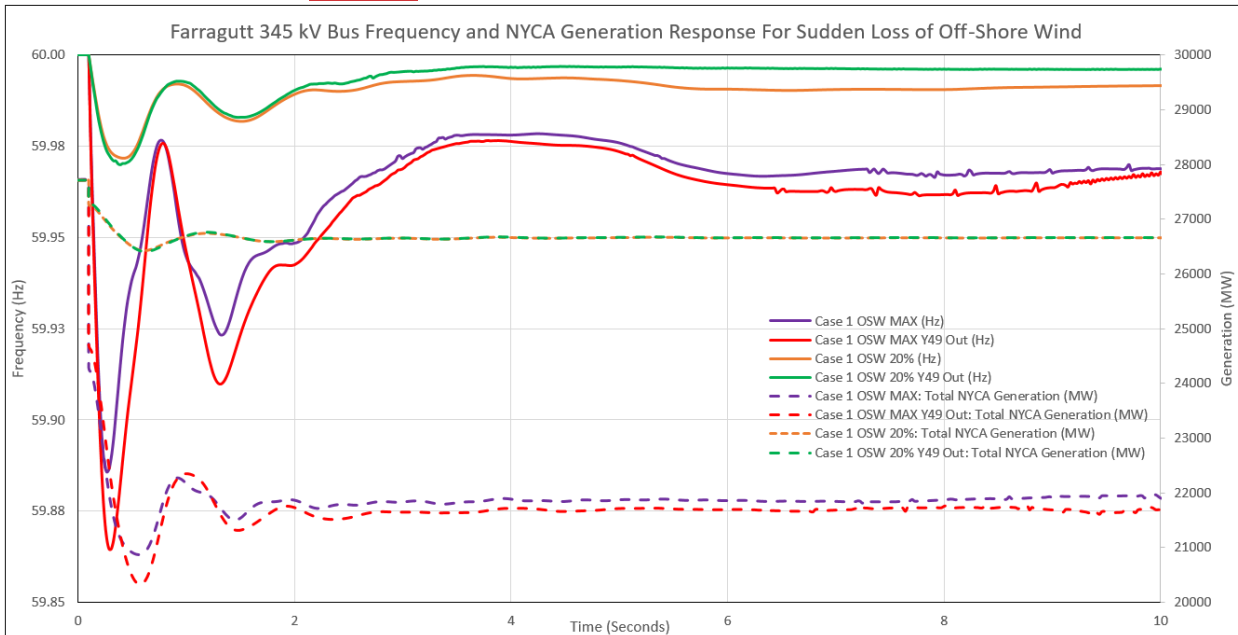

Figure 85: Summary of System Frequency Response Characteristics - Case 1

| Description | Nadir Point (Hz) | Rate of Change of Frequency (Hz/Sec) | Settling Frequency (Hz) (10 Seconds) | Equivalent NYCA System Inertia (Heg) | NYCA Inertia Online (MVA-s) |
|---------------|------------------|--------------------------------------|--------------------------------------|--------------------------------------|-----------------------------|
| N-1 OSW Max | 59.89 | -1.03 | 59.97 | 1.47 | 83,770 |
| N-1-1 OSW Max | 59.86 | -1.1 | 59.97 | 1.52 | 88,607 |
| N-1 OSW 20% | 59.97 | -0.19 | 59.99 | 1.67 | 105,099 |
| N-1-1 OSW 20% | 59.97 | -0.2 | 59.99 | 1.67 | 105,099 |

Figure 86 and Figure 88 show that with higher equivalent system inertia, lower ROCOF is observed. This is due to more synchronous generation in-service in the model with OSW dispatched at 20% output as compared to having less synchronous generation in-service in the model with OSW dispatched at maximum output.

As observed in [redacted], the loss of OSW event results in damped electrical power swing across the system. The total electrical power loss shown in [redacted] shows that the loss of generation from the OSW but also includes the impacts of electrical power swings which in total impact the system frequency response of the system. For example, there are multiple rises and dips in frequency shown in [redacted] which correspond with the rises and dips in electrical power output. The role of generator governors is to respond to these rises and dips in electrical power output to ultimately settle the system response.

Figure 86 and Figure 87 provide the system frequency response details under light load conditions. Figure 22 provides the system frequency response details under shoulder load conditions. For all cases the system frequency response passes criteria. Additionally, no UFLS is triggered.

Figure 86: System Frequency Response and NYCA Generation Response for the Loss of Off-Shore Wind - Case 3

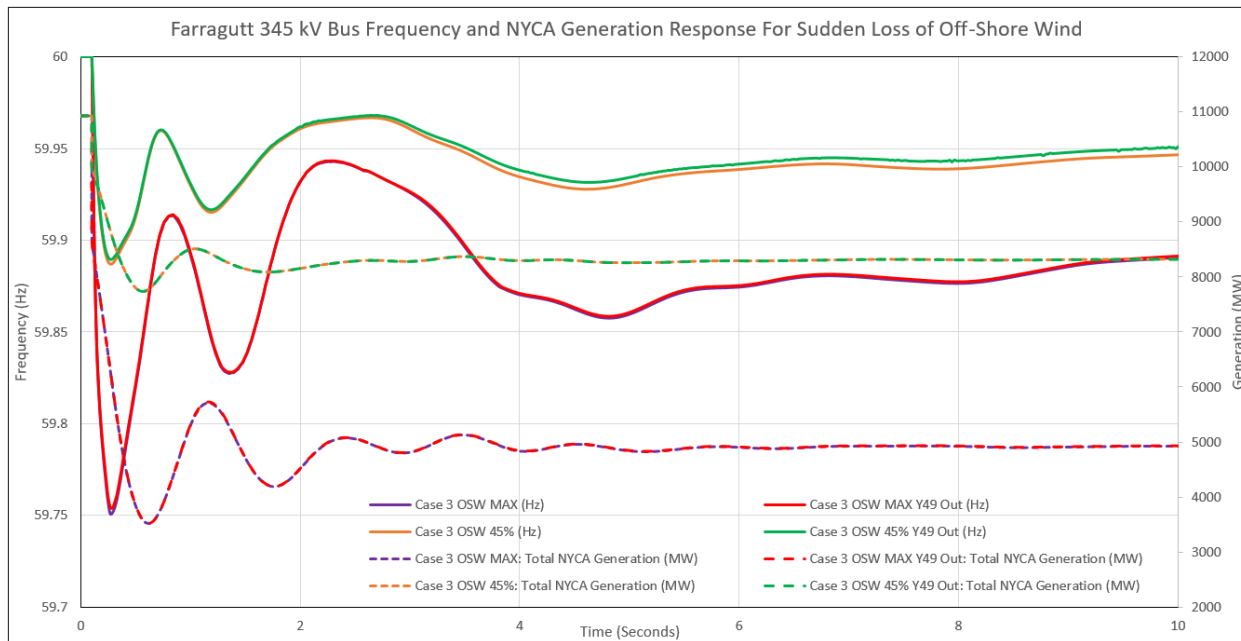

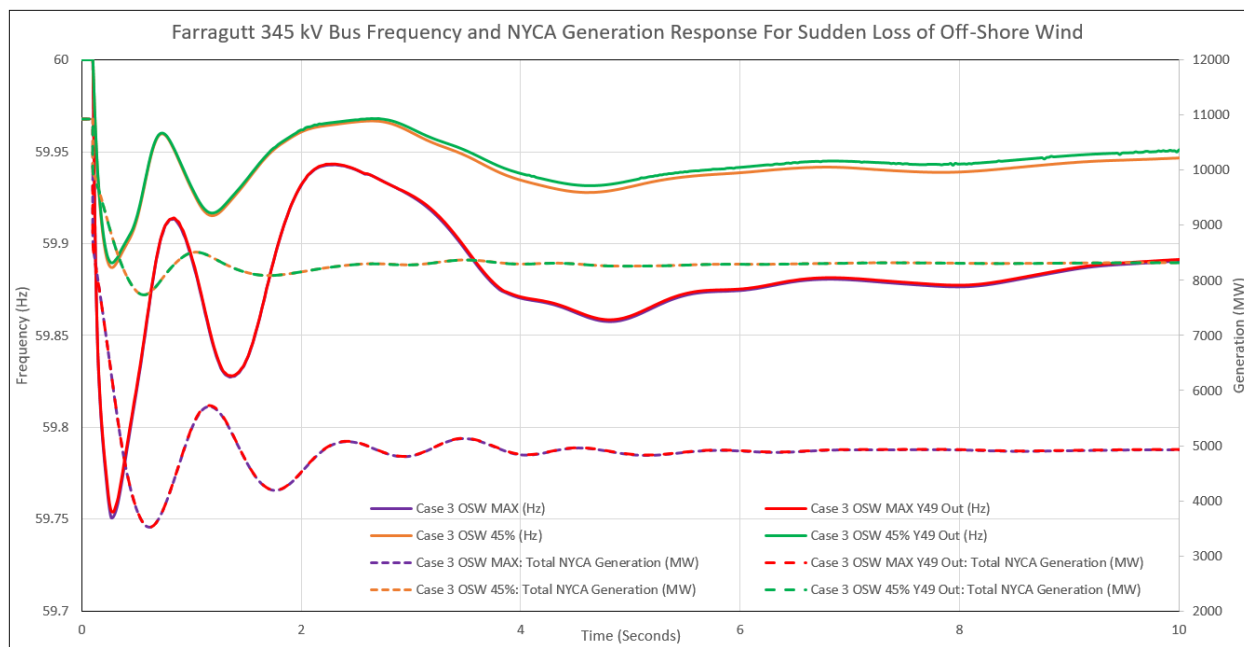

Figure 87: Summary of System Frequency Response Characteristics - Case 3

| Description | Nadir Point (Hz) | Rate of Change of Frequency (Hz/Sec) | Settling Frequency (Hz) (10 Seconds) | Equivalent NYCA System Inertia (Heq) | NYCA Inertia Online (MVA-s) |
|---------------|------------------|--------------------------------------|--------------------------------------|--------------------------------------|-----------------------------|
| N-1 OSW Max | 59.75 | -2.91 | 59.89 | 1.7 | 56,451 |
| N-1-1 OSW Max | 59.75 | -2.87 | 59.89 | 1.7 | 56,451 |
| N-1 OSW 45% | 59.89 | -1.24 | 59.95 | 1.79 | 63,129 |
| N-1-1 OSW 45% | 59.89 | -1.22 | 59.95 | 1.79 | 63,129 |

| Description | Nadir Point (Hz) | Rate of Change of Frequency (Hz/Sec) | Settling Frequency (Hz) (10 Seconds) | Equivalent NYCA System Inertia (Heq) | NYCA Inertia Online (MVA-s) |
|---------------|------------------|--------------------------------------|--------------------------------------|--------------------------------------|-----------------------------|
| N-1 OSW Max | 59.75 | -2.91 | 59.89 | 1.7 | 56,451 |
| N-1-1 OSW Max | 59.75 | -2.87 | 59.89 | 1.7 | 56,451 |
| N-1 OSW 45% | 59.89 | -1.24 | 59.95 | 1.79 | 63,129 |
| N-1-1 OSW 45% | 59.89 | -1.22 | 59.95 | 1.79 | 63,129 |

Figure 88: System Frequency Response and NYCA Generation Response for the Loss of ~~Off-Shore~~Offshore Wind - Case 6

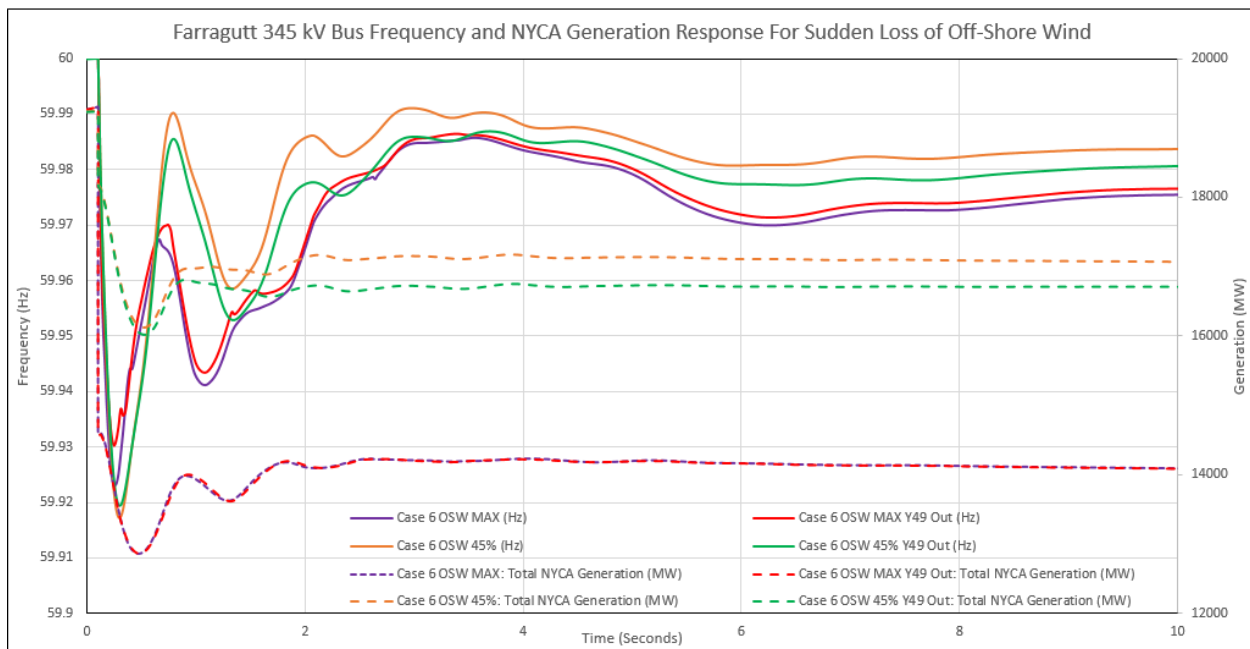
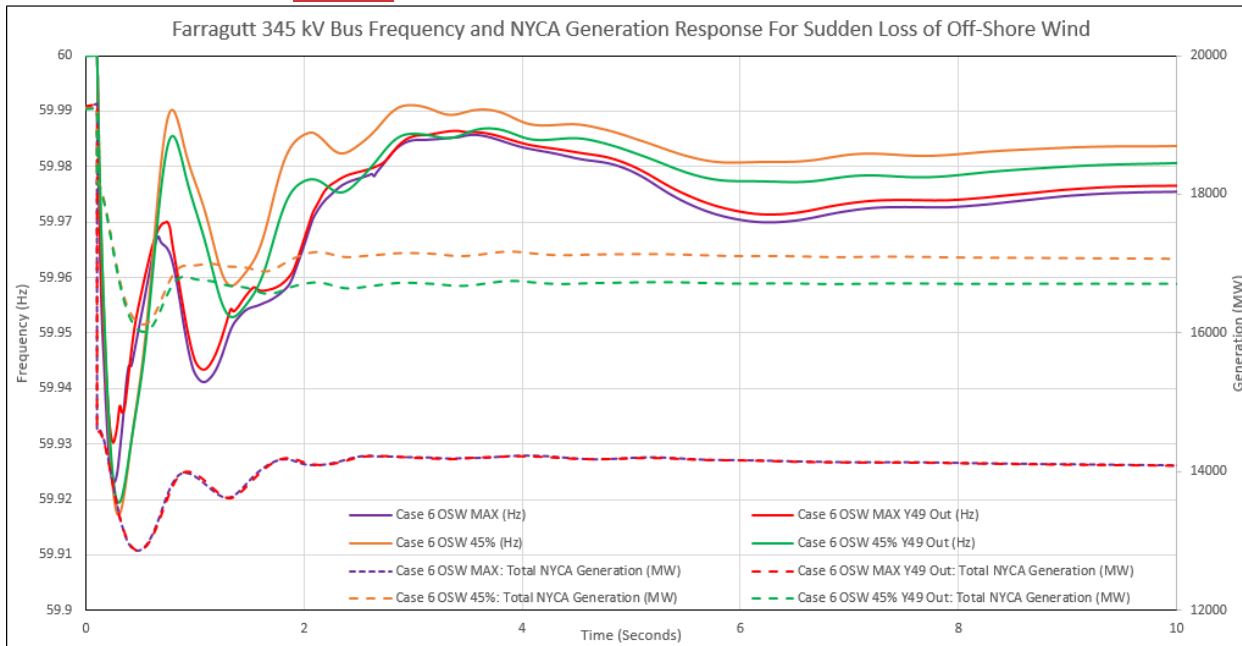

Figure 89: Summary of Frequency Response Characteristics - Case 6

| Description | Nadir Point (Hz) | Rate of Change of Frequency (Hz/Sec) | Settling Frequency (Hz) (10 Seconds) | Equivalent NYCA System Inertia (Heq) | NYCA Inertia Online (MVA-s) |
|---------------|------------------|--------------------------------------|--------------------------------------|--------------------------------------|-----------------------------|
| N-1 OSW Max | 59.92 | -0.91 | 59.98 | 1.22 | 47,326 |
| N-1-1 OSW Max | 59.93 | -0.83 | 59.98 | 1.22 | 47,326 |
| N-1 OSW 45% | 59.92 | -0.76 | 59.98 | 1.42 | 51,640 |
| N-1-1 OSW 45% | 59.92 | -0.73 | 59.98 | 1.42 | 51,640 |

Impact of System Inertia & Governor Response on System Frequency

Although all cases show a stable system response, the loss of OSW event under light load conditions has a noticeably poorer system response in terms of the point at which the system frequency response is arrested (or “nadir” point) as well as primary frequency response characteristics. In general, a light load case has less synchronous generation operating on the system which results in less inertia compared to instances of higher load. Figure 17 shows the system frequency response, under Case 3 conditions with OSW at its maximum and the Y49 cable out of service, as seen across some of the buses located in NYCA and in the adjacent areas. Figure 17 demonstrates that, although the primary system frequency response after the loss of OSW across these buses is different, the frequency recovery across these buses is similar.

Figure 90: Case 3 (Light Load) System Frequency Response (Including External Ares) with Y49 Out-of-Service

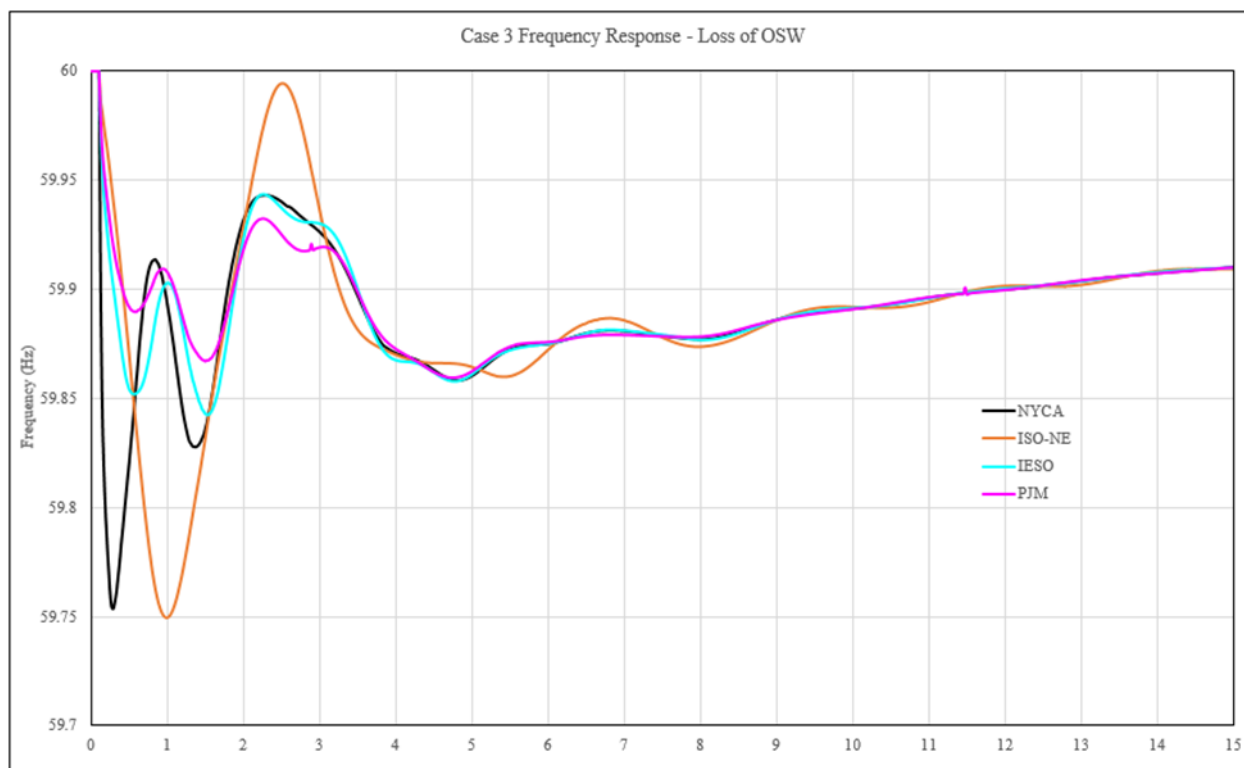

As renewable generation interconnects to the system and synchronous generation retires, an overall decrease in the average system inertia is expected. Since the future renewable models interconnecting in the other areas are not available for this assessment, the impact of external area inertia on maintaining system stability was investigated by reducing the inertia constant of the synchronous generators in the other areas. Thus, in order to model and study penetration of renewable resources across the other portion of the Eastern Interconnection, as a proxy, the inertia constant (H) of all the synchronous generator models was reduced, which in turn will reduce the overall inertia of the system. For this study, the inertia constant across the Eastern Interconnection, except for the NYCA generators, was reduced by approximately 50% (NYCA generators were not reduced as we included age-based generation removals and the ~~70x30~~ 70x30 renewable dispatch in the development of the cases).

As seen in Figure 24, the frequency response observed with inertia constant (H) reduced by approximately 50% are slightly inferior to the system frequency response with 100% of the inertia constant. However, the simulation indicated an overall stable response. The summary of the system frequency response characteristics for the Eastern Interconnection is provided in Figure 25. As seen in Figure 19, the nadir point for the frequency in New York is reduced along with an increased ROCOF. As there was no change in this simulation to the governor response, the primary frequency response through 15 seconds is insignificantly changed.

Figure 91: System Frequency Response with External Area Inertia Constant (H) Reduced by Approx. 50%

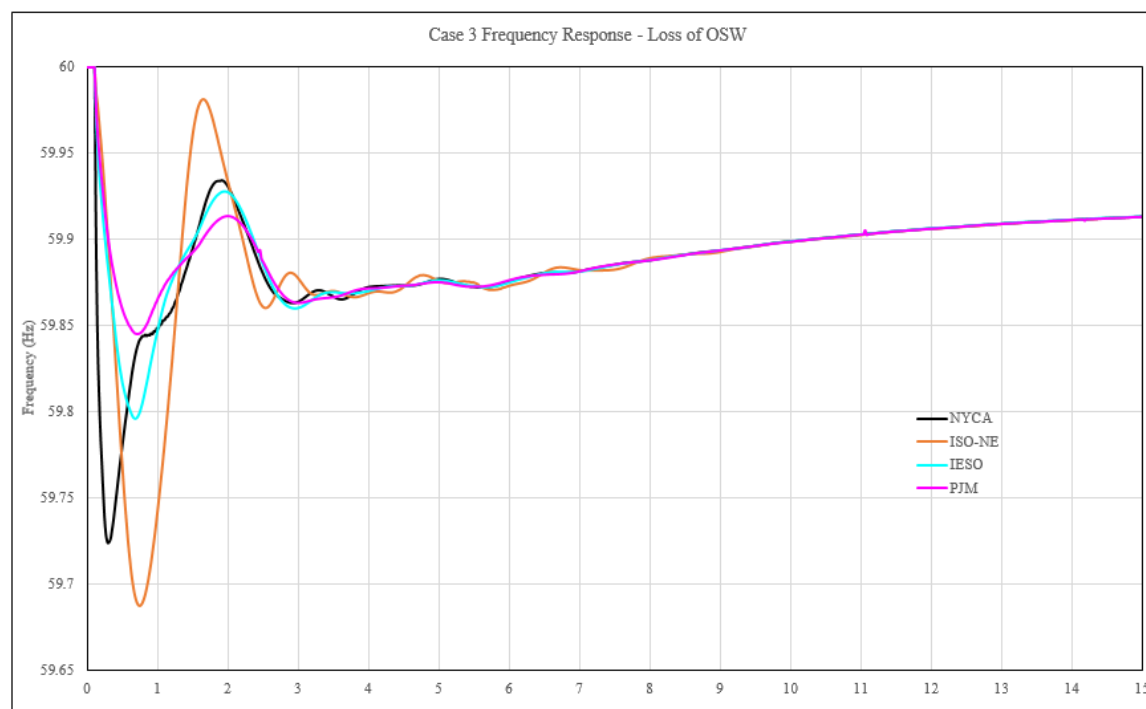

Figure 92: Summary of System Frequency Response Characteristics - With H Reduced by Approx. 50% in External Areas

| Description | Nadir Point (Hz) | Rate of Change of Frequency (Hz/Sec) | Settling Frequency (Hz) (10 Seconds) | Equivalent Eastern Interconnection System Inertia (Heq) | Eastern Interconnection Inertia Online (MVA-s) |
|--|------------------|--------------------------------------|--------------------------------------|---|--|
| Case 3 N-1-1 OSW Max | 59.75 | -2.87 | 59.89 | 3.38 | 1,657,602 |
| Case 3 N-1-1 OSW Max with 50% Inertia Constant | 59.72 | -2.99 | 59.9 | 1.75 | 857,026 |

In addition to the expectation for reduced system inertia with increased renewable resource penetration it is also anticipated that the governor responsiveness may be increasingly squelched. To account for this expectation an additional evaluation was performed, in addition to the reduction in inertia by 50%, by squelching the governor response characteristics of generators in the eastern interconnection that have more than 200 MVA in capacity and that are classified as full responsive.⁶¹

The system frequency response and response characteristics seen for this condition for the loss of OSW are shown in Figure 26. The frequency response characteristics for this condition are the same as

⁶¹ See ERAG MMWG Manual for the process on changing a governor response to squelched.

shown in Figure 25 with 50% inertia constant. As observed from comparing Figure 24 to Figure 26 and Figure 25 to Figure 27, the change in nadir point in each area is not impacted by squelching the governor response as the nadir point is primarily impacted by system inertia. However, the frequency recovery response is different. In the case with system inertia reduced by 50%, the bus frequency recovers to 59.9 Hz in 10 seconds with increased frequency improvement seen through 15 seconds, ~~whereas~~ ~~whereas~~ in the case with system inertia reduced by 50% and generators squelched, the frequency does not recovery to 59.9 Hz by 15 seconds. Thus, it is seen from this analysis that reduction in system inertia can degrade the frequency nadir and ROCOF, while the reduction in the governor response capabilities impacts the stabilizing and recovery characteristics of the system frequency response.

Figure 93: System Frequency Response Characteristic with External Area Inertia Constant (H) Reduced by 50% and Increased Governor Squelching

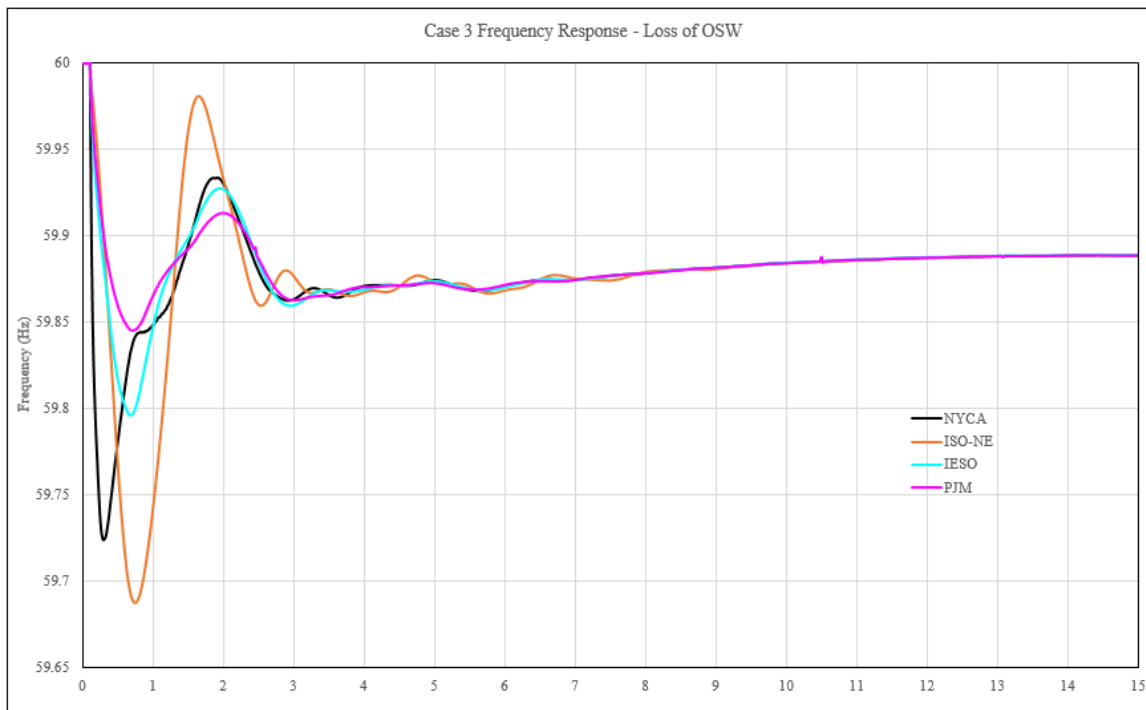
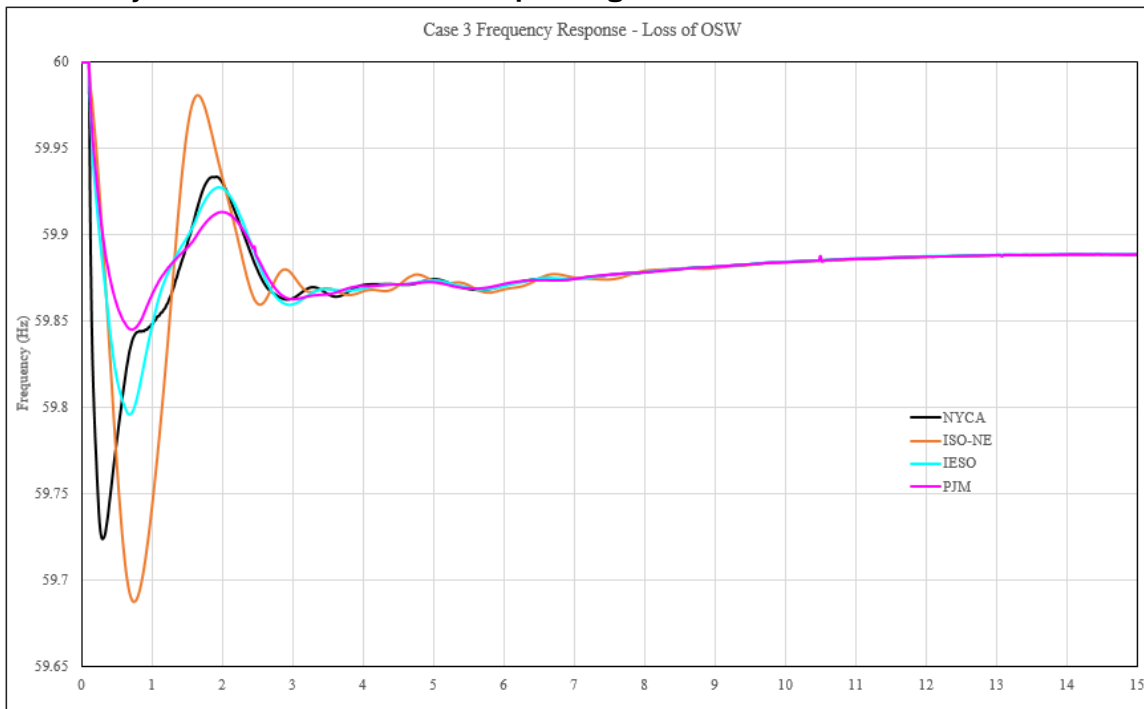

Figure 94: Summary of Frequency Response Characteristics - With H Reduced by Approx. 50% and Increased Governor Squelching

| Description | Nadir Point (Hz) | Rate of Change of Frequency (Hz/Sec) | Settling Frequency (Hz) (10 Seconds) | Equivalent Eastern Interconnection System Inertia (Heq) | Eastern Interconnection Inertia Online (MVA-s) |
|---|------------------|--------------------------------------|--------------------------------------|---|--|
| Case 3 N-1-1 OSW Max with 50% Inertia Constant and Governor Squelched | 59.72 | -2.99 | 59.88 | 1.75 | 857,026 |

Short-Circuit Ratio

Background on Short-Circuit Ratio

With the planned increased to renewable energy resources on the system, there are several important considerations to evaluate in addition to traditional steady state and dynamics analysis. It is expected that many renewable generators will connect to the grid asynchronously through power electronic devices (*i.e.*, inverter-based resources). The ability of inverter-based resources to function properly often depends on the strength of the grid at or near the interconnection of the resources. Grid strength is a commonly used term to describe how the system responds to system changes (*e.g.*, changes in load, and equipment switching). In a “strong” system, the voltage and angle are relatively insensitive to changes in current injection from the inverter-based resource. Inverter-based resources connecting to a portion of the system rich in synchronous generation that is electrically close or relatively large is likely connecting to a strong system. Inverter-based resources connected to a “weak” portion of the grid may be subject to instability, adverse control interactions, and other issues.⁶²

As documented by NERC, inverter-based resources are particularly susceptible to weak grid conditions for several reasons. First, they have little or no inertia in their mechanical systems to provide the synchronizing power inherent in more traditional generation forms. Their ability to provide expected real and reactive power is dependent on the electronic controls which separate the power source from the grid. These controls depend on a stable voltage reference from the grid. As the system is weakened, the voltage reference becomes less stable thereby leading to unstable controls behavior.

The prevailing measure of system strength is the short-circuit ratio calculation. Short-circuit ratio is

⁶² North American Electric Reliability Corporation, Integrating Inverter-Based Resources into Low Short Circuit Strength Systems Reliability Guideline, dated December 2017.

defined as the ratio of short-circuit apparent power (SCMVA) at the point of interconnection (POI) from a 3-phase fault at the POI to the power rating of the resource.

$$\text{Short Circuit Ratio}_{POI} = \frac{SCMVA_{POI}}{MW}$$

For example, a 300 MW inverter-based resource with a SCMVA of 717 MVA equates to a short-circuit ratio of 2.39. This method of calculating short-circuit ratio is most appropriate when the inverter-based resource is not in close proximity to other inverter-based resources. The weighted short-circuit ratio (**WSCR**) is a more appropriate methodology for determining the short-circuit ratio amongst closely connected inverter-based resources where $SCMVA_i$ is the short-circuit capacity at bus i without current contribution from non-synchronous generation and $PRMW_i$ is the MW rating of non-synchronous generation to be connected at bus i . N is the number of inverter-based resource plants fully interacting with each other and i is the plant index.

$$\text{WSCR Weighted Short - Circuit Ratio} = \frac{\sum_i^N SCMVA_i \times P_{RMW_i}}{(\sum_i^N P_{RMW_i})^2}$$

Short-circuit ratio or **WSCR weighted short-circuit ratio** calculations should be used as a guideline to identify potential areas of concern. These calculations are a guideline to show areas where additional studies may need to be performed when connecting inverter-based resources. Once weak areas are identified, other analysis may need to be performed, such as sub-synchronous control interaction studies or electromagnetic transient. A typical threshold for identifying low short-circuit ratio is 3.0.⁶³

NYCA Short-Circuit Ratio

The NYISO evaluated short-circuit ratio and **WSCR weighted short-circuit ratio** under the **70x3070 x 30** scenario transmission security base case assumptions. Short-circuit ratio and **WSCR weighted short-circuit ratio** are calculated for all the new and existing wind and solar plants.

Figure 28 Figure 95 shows a summary of the buses in the NYCA that have **ana** short-circuit ratio of less than 3.0. Appendix A provides a summary of all evaluated buses short-circuit ratio. **Figure 29 Figure 96** shows where these buses are located within New York where intensity inversely proportional to short-circuit ratio to emphasize weak locations.

⁶³ North American Electric Reliability Corporation, Short-Circuit Modeling and System Strength, dated February 2018

Figure 95: NYCA Buses with Short-Circuit Ratio Less than 3.0

| Bus Name | Bus Voltage (kV) | Lowest SCR (1) |
|----------------|------------------|----------------|
| North Catskill | 115 | 1.4 |
| Bennett | 115 | 1.5 |
| Black River | 115 | 1.7 |
| Marshville 115 | 115 | 2.2 |
| Patnode | 230 | 2.7 |

Notes:

(1) The reported value is the lowest SCR in consideration of all six 70x30 cases. For most buses the SCR is similar across all six cases.

| Bus Name | Bus Voltage (kV) | Lowest Short-Circuit Ratio (1) |
|----------------|------------------|--------------------------------|
| North Catskill | 115 | 1.4 |
| Bennett | 115 | 1.5 |
| Black River | 115 | 1.7 |
| Marshville 115 | 115 | 2.2 |
| Patnode | 230 | 2.7 |

Notes:

(1) The reported value is the lowest short-circuit ratio in consideration of all six 70x30 cases. For most buses the short-circuit ratio is similar across all six cases.

Figure 96: Case 1 Short-Circuit Ratio Locations

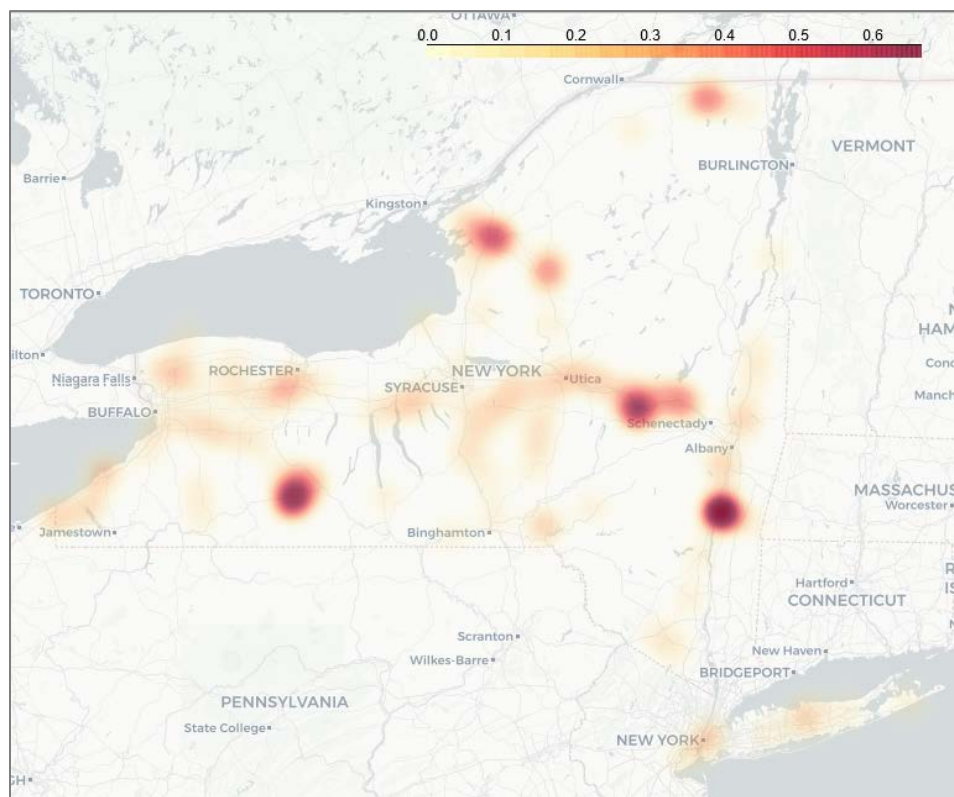

In performing the WSCR weighted short-circuit ratio calculations the evaluations included groups of inverter-based generators in a 22-kilometer radius. The 22-kilometer distance is selected because this corresponds to approximately a 0.2° in either longitude or latitude. Figure 30-Figure 97 provides a summary of the buses in NYCA that have a WSCR weighted short-circuit ratio of less than 3.0. Figure 31-Figure 98 provides the geographical representation of the short-circuit ratio values across the NYCA system.

Figure 97: NYCA Buses with WSCR-Weighted Short-Circuit Ratio Less than 3.0

| Bus Name | Bus Voltage (kV) | Lowest WSCR (1) |
|---|-----------------------|-----------------|
| North Catskill & Indep C | 115 | 1.1 |
| Meco 115 & Marshville 115 & Clinton | 115 | 1.3 |
| Black River & Coffeen Street | 115 | 1.4 |
| Bennett & Q# 422 Eight Point Wind Energy Center | 115 | 1.4 |
| Willis E & Ryan & Patnode & Jericho Rise Wind Transformer 1 | 230 & 230 & 230 & 115 | 1.6 |
| Chases L & Rector & Bremen & Lowville- Maple Avenue | 230 & 230 & 115 & 115 | 2.1 |
| Avoca & Canadaigua Wind Tap & Howard Wind 115 | 230 & 230 & 115 | 2.3 |
| Whitman & Fenner Wind Farm | 115 | 2.7 |
| Lyme Tap & Lyme | 115 | 2.8 |
| Stilesville | 115 | 3 |

Notes:

(1) The reported value is the lowest SCR in consideration of all six 70x30 cases. For most buses the SCR is similar across all six cases.

| Bus Name | Bus Voltage (kV) | Lowest Weighted Short-Circuit Ratio (1) |
|---|-----------------------|---|
| North Catskill & Indep C | 115 | 1.1 |
| Meco 115 & Marshville 115 & Clinton | 115 | 1.3 |
| Black River & Coffeen Street | 115 | 1.4 |
| Bennett & Q# 422 Eight Point Wind Energy Center | 115 | 1.4 |
| Willis E & Ryan & Patnode & Jericho Rise Wind Transformer 1 | 230 & 230 & 230 & 115 | 1.6 |
| Chases L & Rector & Bremen & Lowville-Maple Avenue | 230 & 230 & 115 & 115 | 2.1 |
| Avoca & Canadaigua Wind Tap & Howard Wind 115 | 230 & 230 & 115 | 2.3 |
| Whitman & Fenner Wind Farm | 115 | 2.7 |
| Lyme Tap & Lyme | 115 | 2.8 |
| Stilesville | 115 | 3 |

Notes:

(1) The reported value is the lowest short-circuit ratio in consideration of all six 70x30 cases. For most buses the short-circuit ratio is similar across all six cases.

Figure 98: Case 1 Weighted Short-Circuit Ratio Locations

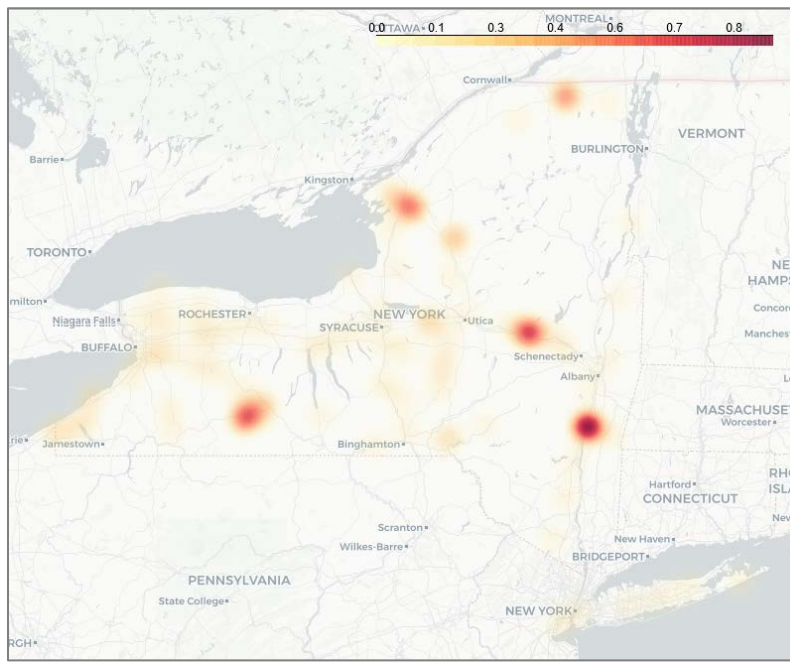

Voltage Flicker

As the transmission system changes, another important consideration is light flicker caused by the connection of large reactive devices, such as a shunt reactive device or a load. Some New York Transmission Owners have flicker (or Delta-V) criteria. For example, Avangrid criteria for voltage flicker is a change of 3% in bus voltage.⁶⁴

The solution methodology for this analysis is the same as used for switching studies (triangularized Y matrix network solution activity or TYSL). The TYSL solution methodology is designed for situations where the internal flux linkages of generators are assumed to remain unchanged as load or other devices are switched into the system. While this solution methodology does provide an instantaneous change to the bus voltage due to a switching event, other fast electromagnetic transient variations are not captured. The effects of voltage change of newly added load is influenced by the statuses of generations near that load. If all available generation near the load is in-service, and as these generators would control their “internal” voltage, the observed voltage drop would then be less in magnitude than the instances with some or all nearby generators out-of-service. The flicker calculation also assumes that wind or solar farms are stable in controlling their POI and terminal voltages.

The first step in this analysis is to determine the size of reactive device at a given NYCA BES bus using the low renewable generation (*i.e.*, Case 2, Case 4, and Case 5) that results in a 3% change in bus voltage. Once the size of the reactive device is known, the second step is to simulate the change in bus voltage under high renewable generation conditions (*i.e.*, Case 1, Case 3, and Case 6). [Figure 32](#)[Figure 99](#) provides a summary the largest change in bus voltage observed between peak load, shoulder load, and light load conditions. The Delta-V column in [Figure 32](#) shows the additional voltage drop (*i.e.*, beyond 3%). For example, in Case 2 a reactive load was placed at the Nine Mile Point 345 kV bus that resulted in a 3% change in bus voltage. When this reactive load was placed in Case 1 the resulting change in voltage was a 5.43% decline. The difference in bus voltages is 2.43% which is reported in [Figure 32](#), [Figure 33](#), [Figure 34](#), and [Figure 35](#)[Figure 99](#). [Figure 100](#), [Figure 101](#), and [Figure 102](#) provide a visual representation of the flicker between the peak, light load, and shoulder load cases, respectively. As shown on these figures the flicker results are influenced by the statuses of generations near the test load.

⁶⁴ [Avangrid Electric Transmission Planning Manual](#), Technical Manual TM 1.2.00, dated June 29, 2019.

Figure 99: Summary of NYCA Flicker

| Bus Name | Bus Voltage (kV) | Delta-V | Peak/Light Load/Shoulder Load |
|------------------------------|------------------|---------|-------------------------------|
| Bayonne | 138 | -3.39% | Shoulder Load |
| Nine Mile Point 1 | 345 | -2.43% | Peak Load |
| Station 13a, Bus #1 & Bus #2 | 115 | -1.86% | Peak Load |
| Marshville 115 | 115 | -1.80% | Shoulder Load |
| Scriba | 345 | -1.67% | Peak Load |
| Oswego | 345 | -1.67% | Peak Load |
| Fitzpatrick | 345 | -1.67% | Peak Load |
| Independence | 345 | -1.66% | Peak Load |
| Albany Steam | 115 | -1.54% | Light Load |
| Clinton Avenue | 115 | -1.52% | Shoulder Load |

Figure 100: Peak Load Flicker⁶⁵

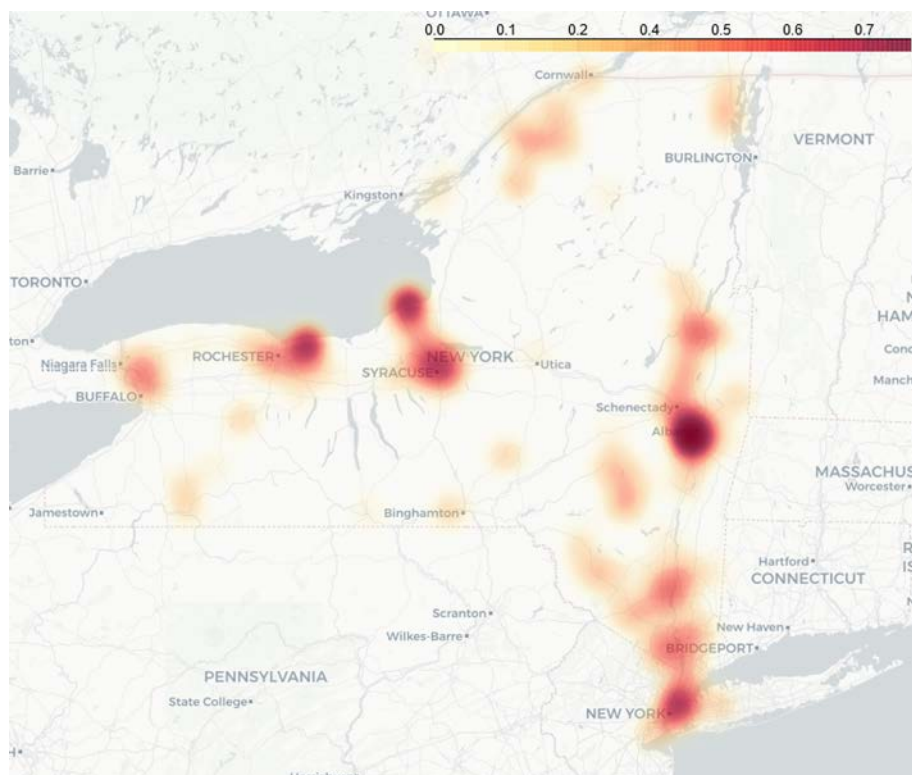

⁶⁵ In the plot scale, a 0 represents no change in per-unit voltage and a 1 represents at 0.03 per-unit voltage decline.

Figure 101: Light Load Flicker

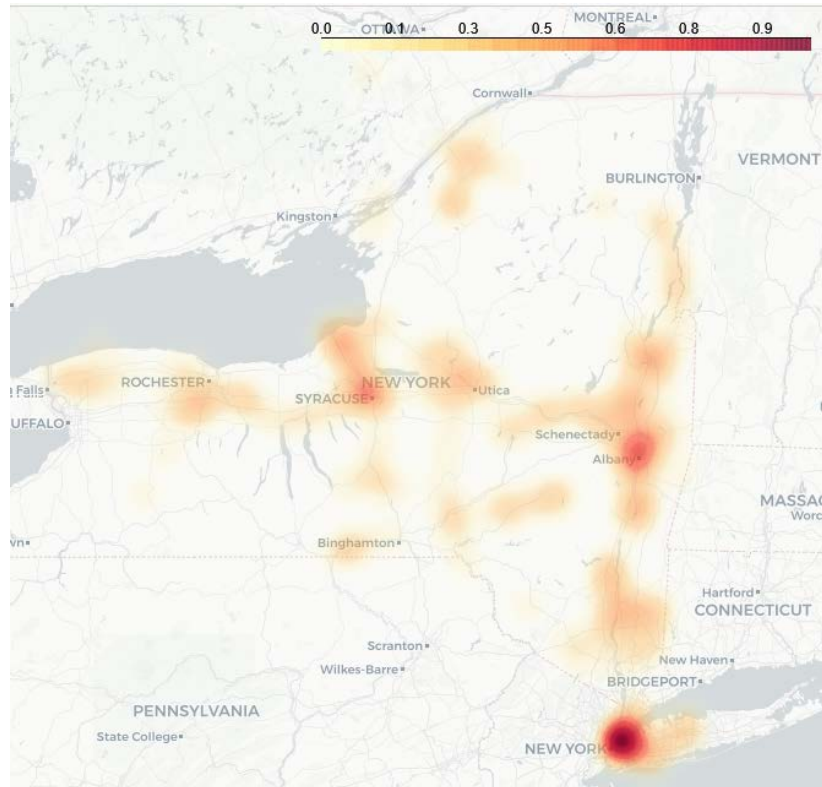
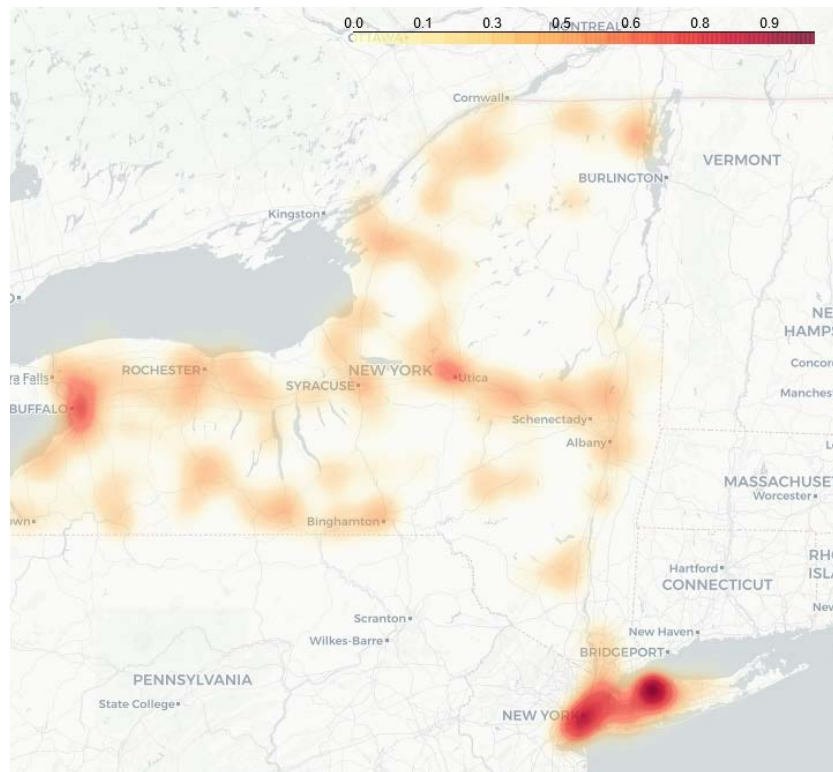

Figure 102: Shoulder Load Flicker



Appendix G – Reliability Planning Process

This appendix presents an overview of the NYISO's Reliability Planning Process. A detailed discussion of the Reliability Planning Process, including applicable Reliability Criteria, is contained in NYISO Manual entitled: *Reliability Planning Process Manual*, which is posted on the NYISO's website⁶⁶.

The NYISO Reliability Planning Process is an integral part of the NYISO's overall Comprehensive System Planning Process (CSPP).

The CSPP is comprised of four components:

1. Local Transmission Planning Process (LTPP),
2. Reliability Planning Process (RPP), along with the Short-Term Reliability Process (STRP),
3. Economic Planning Process, and
4. Public Policy Transmission Planning Process.

Under the LTPP, the local Transmission Owners (TOs) perform transmission studies for their transmission areas according to all applicable criteria. This process produces the Local Transmission Owner Plan (LTP), which feeds into the NYISO's determination of system needs through the CSPP. Links to the Local Transmission Owner Plans (LTPs) can be found on the NYISO's website⁶⁷.

The second component in the CSPP cycle is the RPP, covering year 4 through year 10 following the year of starting the study, in conjunction with the STRP, covering year 1 through year 5 following the STAR Start Date of the study. The RPP and STRP requirements are described in detail in the RPP Manual and Attachments Y and FF to the OATT, respectively. Under the biennial process for conducting the RPP, the reliability of the New York Bulk Power Transmission Facilities (BPTF) is assessed, any Reliability Needs are identified, solutions to identified needs are proposed and evaluated for their viability and sufficiency to satisfy the identified needs, and the more efficient or cost-effective transmission solution to the identified needs is selected by the NYISO.

During the Reliability Planning Process, the NYISO conducts the Reliability Needs Assessment (RNA) and Comprehensive Reliability Plan (CRP). The RNA evaluates the adequacy and security of the BPTFs over the RNA Study Period (i.e., years 4 through 10 following the year in which the RNA is conducted). In

⁶⁶ Link to RPP Manual: https://www.nyiso.com/documents/20142/2924447/rpp_mnl.pdf/85b28e6b-16b0-0ce7-60f3-c2291733acea

⁶⁷ Link to LTPP: <https://www.nyiso.com/documents/20142/3632262/Local-Transmission-Owner-Planning-Process-LTPP.pdf/025b47f1-d90a-94e3-8eba-c21e7a6131aa>

identifying resource adequacy needs, the NYISO identifies the amount of resources in megawatts (MW, known as “compensatory MW”) and the locations in which they are needed to meet those needs.

Following approval of the RNA by its Board of Directors and before NYISO issues a solicitation for regulated backstop, market-based, and alternative regulated solutions, the NYISO will request updated LTPs, NYPA transmission plans, and other status updates relevant to reducing, or eliminating, the Reliability Needs, as timely received from Market Participants, Developers, TOs, and other parties. Any such update must meet, in NYISO’s determination, the RNA Base Case inclusion rules, as defined in Section 3 of the RPP Manual. If there are remaining Reliability Needs after these updates, the NYISO will request solutions for the remaining Reliability Needs. These solutions will be then undergoing the Viability and Sufficiency Assessments under the CRP, and if needed and as applicable, Transmission Evaluation and Selection. The CRP documents the solutions determined to be viable and sufficient to meet the identified Reliability Needs. The NYISO ranks any regulated transmission solutions submitted for the Board to consider for selection of the more efficient or cost-effective transmission project. If built, the selected transmission project would be eligible for cost allocation and recovery under the NYISO’s tariff.

There are two different aspects to analyzing the BPTF’s reliability in the RNA: adequacy and security. Adequacy is a planning and probabilistic concept. A system is adequate if the probability of having sufficient transmission and generation to meet expected demand is equal to or less than the system’s standard, which is expressed as a loss of load expectation (LOLE). The New York State bulk power system is planned⁶⁸ to meet an LOLE that, at any given point in time, is less than or equal to an involuntary load disconnection that is not more frequent than once in every 10 years, or 0.1 days per year. This requirement also forms the basis of New York’s installed reserve margin (IRM) resource adequacy requirement.

Security is an operating and deterministic concept. This means that possible events are identified as having significant adverse reliability consequences. The system is planned and operated so that the system can continue to serve load even if these events occur. Security requirements are sometimes referred to as N-1 or N-1-1. N is the number of system components. An N-1 requirement means that the system can withstand single disturbance events (*e.g.*, generator, bus section, transmission circuit, breaker failure, double-circuit tower) without violating thermal, voltage and stability limits or before resulting in unplanned loss of service to consumers. An N-1-1 requirement means that the Reliability Criteria apply

⁶⁸ NYSRC Reliability Rules: “The loss of load expectation (LOLE) of disconnecting firm load due to resource deficiencies shall be, on average, no more than 0.1 day per year. LOLE evaluations shall make ~~due~~ allowance for demand uncertainty, scheduled outages and deratings, forced outages and deratings, assistance over interconnections with neighboring control areas, NYS Transmission System emergency transfer capability, and capacity and/or load relief from available operating procedures.”

after any critical element such as a generator, a transmission circuit, a transformer, series or shunt compensating device, or a high voltage direct current (HVDC) pole has already been lost. Generation and power flows can be adjusted by the use of 10-minute operating reserve, phase angle regulator control, and HVDC control. Following such adjustments, a second single disturbance is analyzed.

The Reliability Planning Process is anchored in the market-based philosophy of the NYISO and its Market Participants, which posits that market solutions should be the preferred choice to meet the identified Reliability Needs reported in the RNA. In the CRP, the reliability of the BPTFs is assessed and solutions to Reliability Needs evaluated in accordance with existing Reliability Criteria of the North American Electric Reliability Corporation (NERC), the Northeast Power Coordinating Council, Inc. (NPCC), and the New York State Reliability Council (NYSRC) as they may change from time to time. These criteria and a description of the nature of long-term bulk power system planning are described in detail in the Reliability Planning Process [Manual](#), and are briefly summarized below.

In the event that market-based solutions do not materialize to meet a Reliability Need in a timely manner, the NYISO designates the Responsible TO or Responsible TOs or developer of an alternative regulated solution to proceed with a regulated solution in order to maintain system reliability. Under the Reliability Planning Process, the NYISO also has an affirmative obligation to report historic congestion across the transmission system. In addition, the draft RNA is provided to the Market Monitoring Unit (MMU) for review and consideration of whether market rules changes are necessary to address an identified failure, if any, in one of the NYISO's competitive markets. If a market failure is identified as the reason for the lack of market-based solutions to a Reliability Need, the NYISO will explore appropriate changes in its market rules with its stakeholders and the MMU. The Reliability Planning Process does not substitute for the planning that each TO conducts to maintain the reliability of its own bulk and non-bulk power systems.

The NYISO does not license or construct projects to respond to identified Reliability Needs reported in the RNA. The ultimate approval of those projects lies with regulatory agencies such as the Federal Energy Regulatory Commission (FERC), the New York State Public Service Commission (NYPSC), environmental permitting agencies, and local governments. The NYISO monitors the progress and continued viability of proposed market and regulated projects to meet identified Reliability Needs, and reports its findings to the Board.

The Short-Term Reliability Process (STRP) uses quarterly Short-Term Assessment of Reliability (STAR) studies to assess the reliability impacts of generator deactivations on both Bulk Power Transmission Facilities (BPTF) and non-BPTF (local) transmission facilities, in coordination with the Responsible

Transmission Owner(s). The STAR is also used by the NYISO, in coordination with the Responsible Transmission Owner(s), to assess the reliability impacts on the BPTF of system changes that are not related to a Generator deactivation. These changes may include adjustments to load forecasts, delays in completion of planned upgrades, long duration transmission facility outages and other system topology changes. Section 38 of the NYISO OATT describes the process by which the NYISO, Transmission Owners, Market Participants, Generator Owners, Developers and other interested parties follow to plan to meet Generator Deactivation Reliability Needs affecting the New York State Transmission System and other Reliability Needs affecting the BPTF (collectively, Short-Term Reliability Needs).

Each STAR will assess a five-year period, with a particular focus on Short-Term Reliability Process Needs (“needs”) that are expected to arise in the first three years of the study period. The STRP is the sole venue for addressing Generator Deactivation Reliability Needs on the non-BPTF, and for BPTF needs that arise in the first three years of the assessment period. With one exception,⁶⁹ needs that arise in years four or five of the assessment period may be addressed in either the STRP or longer-term Reliability Planning Process (RPP).

Each STAR looks out five years from its STAR Start Date. The STRP concludes if a STAR does not identify a need or if the NYISO determines that all identified needs will be addressed in the RPP. Should a STAR identify a need to be addressed in the STRP, the NYISO would request the submission of market-based solutions to satisfy the need along with a Responsible Transmission Owner STRP solution. The NYISO evaluates the viability and sufficiency of the proposed solutions to satisfy the identified needs and selects a solution to address the need. The NYISO reviews the results of the solution or combination of solutions (including an explanation regarding the solution that is selected) with stakeholders and posts a Short-Term Reliability Process Report detailing the determination with stakeholders.

The third component of the CSPP is the Economic Planning Process, which is the process by which the ISO: (i1) develops the System & Resource Outlook and identifies current and future congestion on the New York State Transmission System; (ii2) evaluates in an Economic Transmission Project Evaluation any Regulated Economic Transmission Project proposals to address any constraint(s) on the BPTFs identified in the Economic Planning Process, which transmission projects are eligible for cost allocation and cost recovery under the ISO OATT if approved by a vote of the project’s Load Serving Entity beneficiaries; and (iii3) conducts any Requested Economic Planning Studies. In conducting the process, the ISO will analyze a base case and scenarios that are developed in consultation with stakeholders.

⁶⁹ Generator Deactivation Reliability Needs that arise on local facilities, not on the BPTF, must always be addressed in the STRP.

The fourth component of the CSPP is the Public Policy Transmission Planning Process. Under this process interested entities propose, and the New York State Public Service Commission (NYPSC) identifies, transmission needs on the BPTF driven by Public Policy Requirements. The NYISO then requests that interested entities submit proposed solutions to the identified Public Policy Transmission Need. The NYISO evaluates the viability and sufficiency of the proposed solutions to satisfy the identified Public Policy Transmission Need. The NYISO then evaluates and may select the more efficient or cost-effective transmission solution to the identified need. The NYISO develops the Public Policy Transmission Planning Report that sets forth its findings regarding the proposed solutions. This report is reviewed by NYISO stakeholders and approved by the Board of Directors.

In concert with these four components, interregional planning is conducted with NYISO's neighboring control areas in the United States and Canada under the Northeastern ISO/RTO Planning Coordination Protocol. The NYISO participates in interregional planning and may consider Interregional Transmission Projects in its regional planning processes.

Figure 103: NYISO’s Comprehensive System Planning Process (CSPP)

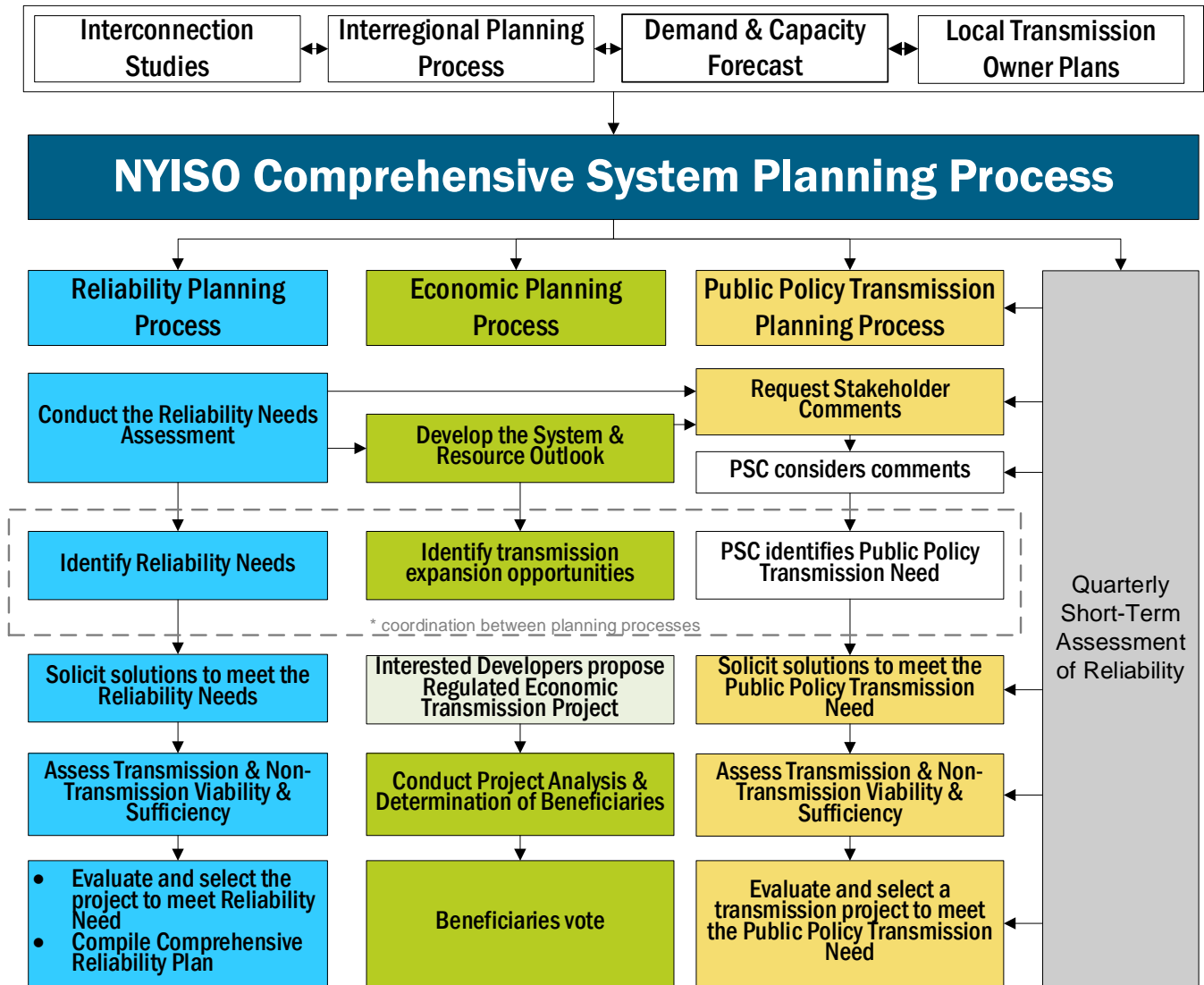
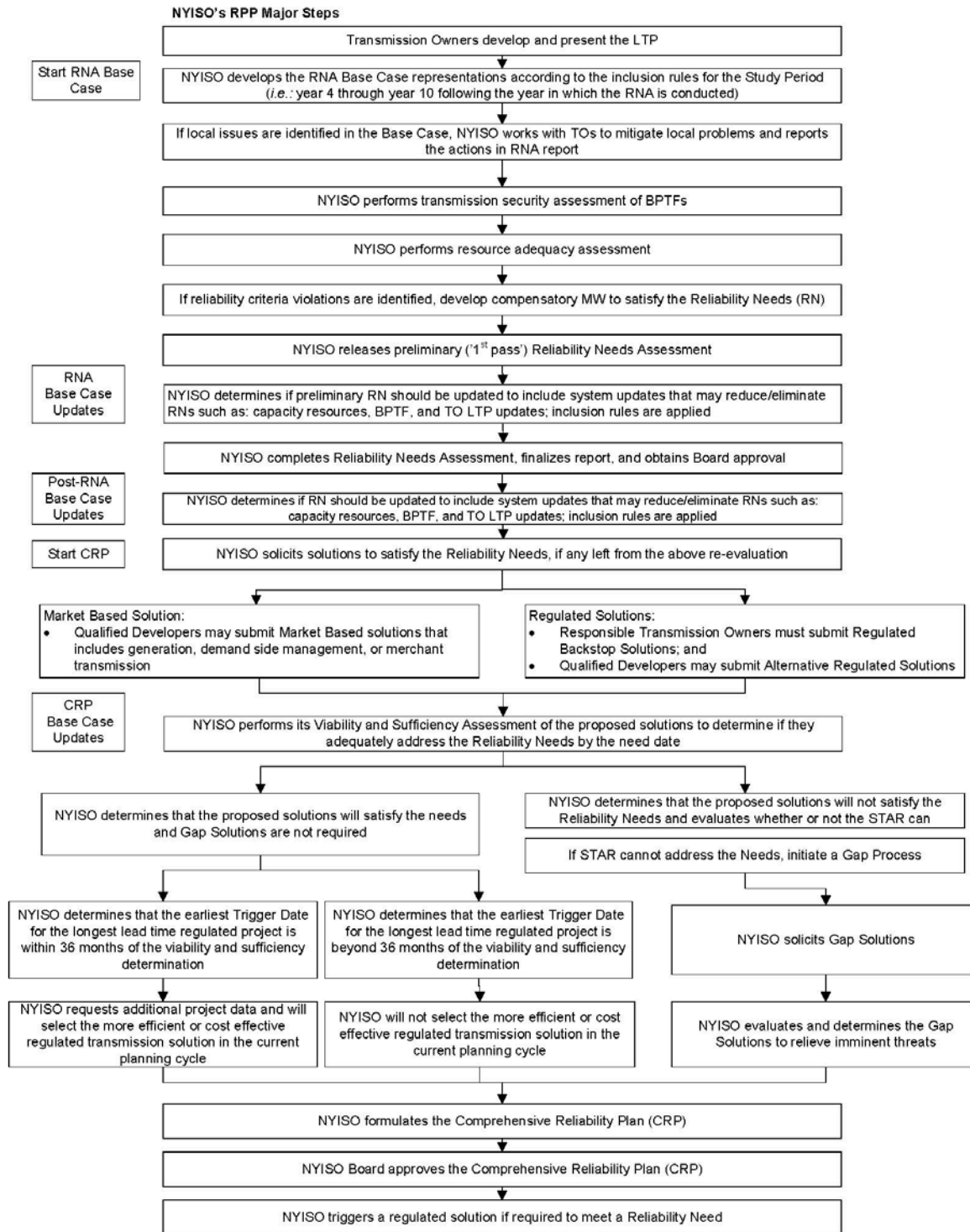

Figure 104: NYISO Reliability Planning Process



Notes:
* If an immediate threat to the reliability of the power system is identified, a Gap Solution outside of the normal RPP cycle may be requested by the NYISO Board.

Appendix H - Reliability Compliance Obligations and Activities

The Reliability Needs Assessment and the CRP are not the only NYISO work product or activity related to reliability planning. The purpose of this section is to discuss the NERC Planning Coordinator and Transmission Planner obligations fulfilled by the NYISO as well as the other NPCC and NYSRC planning compliance obligations. The NYISO has various compliance obligations under NERC, NPCC, and the NYSRC. The periodicity of these requirements varies amongst the standards and requirements. While achieving compliance with all NERC, NPCC, and NYSRC obligations is critical to ensuring the continued reliability of the transmission system, this section primarily discusses in some detail the planning compliance requirements that closely align with this Reliability Needs Assessment. The full details of the compliance obligations are found within the reliability standards and requirements themselves. Publicly available results for the compliance activities listed below are found on the NYISO website under Planning – Reliability Compliance⁷⁰.

The purpose of the NERC Reliability Standards is to “define the reliability requirements for planning and operating the North American bulk power system and are developed using a results-based approach that focuses on performance, risk management, and entity capabilities.” The objective of NPCC Directory #1 and the NYSRC Reliability Rules and Compliance Manual are to provide a “design-based approach” to design and operate the bulk power system to a level of reliability that will not result in the loss or unintentional separation of a major portion of the system from any of the planning and operations contingencies with the intent of avoiding instability, voltage collapse and widespread cascading outages. Figure 4 shows the various NERC Standards with requirements applicable to the NYISO as a NERC registered Planning Coordinator and/or Transmission Planner. The NPCC planning compliance obligations are primarily located in NPCC Regional Reliability Reference Directory #1 Design and Operation of the Bulk Power System. The NYSRC planning compliance obligations are located in the Reliability Rules and Compliance Manual.

Fundamental to any reliability study is the accuracy modeling data provided by the entities responsible for providing the data. The data requirements for the development of the steady state, dynamics, and short circuit models is are provided in the NYISO Reliability Analysis Data Manual (RAD Manual).⁷¹ This data primarily comes from compliance with NERC MOD standards. Much of this data is collected through the annual database update process outlined in the RAD Manual and the annual FERC Form 715 filing to which the transmitting utilities certify, to the best of their knowledge, the accuracy of the

⁷⁰ <https://www.nyiso.com/planning-reliability-compliance>

⁷¹ <https://www.nyiso.com/documents/20142/2924447/rel-anl-data-mnl.pdf>

data. Additional compliance obligations provide for the accuracy of the modeling data through comparison to actual system events (*e.g.*, MOD-026, MOD-026, and MOD-033).

Following the completion of the annual database update, these databases are used for study work such as the Reliability Planning Process, and for many other compliance obligations such as those listed in Figure 4. Planning studies similar to the Reliability Planning Process include the NPCC/NYSRC Area Transmission Reviews (ATRs) and the NERC TPL-001 assessments.

Figure 105: List of NERC Standards for Planning Coordinators and Transmission Planners

| Standard Name | Title | Purpose |
|---------------|--|--|
| FAC-002 | Facility Interconnection Studies | To study the impact of interconnecting new or materially modified Facilities to the Bulk Electric System. |
| FAC-010 | System Operating Limits Methodology for the Planning Horizon | To ensure that System Operating Limits (SOLs) used in the reliable planning of the Bulk Electric System (BES) are determined based on an established methodology or methodologies. |
| FAC-013 | Assessment of Transfer Capability for the Near-Term Transmission Planning Horizon | To ensure that Planning Coordinators have a methodology for, and perform an annual assessment to identify potential future Transmission System weaknesses and limiting Facilities that could impact the Bulk Electric System's (BES) ability to reliably transfer energy in the Near-Term Transmission Planning Horizon. |
| FAC-014 | Establish and Communicate System Operating Limits | To ensure that System Operating Limits (SOLs) used in the reliable planning and operation of the Bulk Electric System (BES) are determined based on an established methodology or methodologies. |
| IRO-017 | Outage Coordination | To ensure that outages are properly coordinated in the Operations Planning time horizon and Near-Term Transmission Planning Horizon. |
| MOD-020 | Providing Interruptible Demands and Direct Control Load Management Data to System Operators and Reliability Coordinators | To ensure that assessments and validation of past events and databases can be performed, reporting of actual demand data is needed. Forecast demand data is needed to perform future system assessments to identify the need for system reinforcement for continued reliability. In addition to assist a proper real-time operating, load information related to controllable Demand-Side Management programs is needed. |
| MOD-026 | Verification of Models and Data for Generator Excitation Control System or Plant Volt/VAR Control Functions | To verify that the generator excitation control system or plant volt/var control function model (including the power system stabilizer model and the impedance compensator model) and the model parameters used in dynamic simulations accurately represent the generator excitation control system or plant volt/var control function behavior when assessing Bulk Electric System (BES) reliability. |
| MOD-027 | Verification of Models and Data for Turbine/Governor and Load Control or Active Power/Frequency Control Functions | To verify that the turbine/governor and load control or active power/frequency control model and the model parameters, used in dynamic simulations that assess Bulk Electric System (BES) reliability, accurately represent generator unit real power response to system frequency variations. |

| Standard Name | Title | Purpose |
|---------------|--|--|
| MOD-031 | Demand and Energy Data | To provide authority for applicable entities to collect Data, energy and related data to support reliability studies and assessments to enumerate the responsibilities and obligations of requestors and respondents of that data. |
| MOD-032 | Data for Power System Modeling and Analysis | To establish consistent modeling data requirements and reporting procedures for development of planning horizon cases necessary to support analysis of the reliability of the interconnected transmission system. |
| MOD-033 | Steady State and Dynamic System Model Validation | To establish consistent validation requirements to facilitate the collection of accurate data and building of planning models to analyze the reliability of the interconnected transmission system. |
| PRC-002 | Disturbance Monitoring and Reporting Requirements | To have adequate data available to facilitate analysis of Bulk Electric System (BES) Disturbances |
| PRC-006 | Automatic Underfrequency Load Shedding | To establish design and documentation requirements for automatic underfrequency load shedding (UFLS) program to arrest declining frequency, assist recovery of frequency following underfrequency events and provide last resort system preservation measures. |
| PRC-006-NPCC | Automatic Underfrequency Load Shedding | The NPCC Automatic Underfrequency Load Shedding (UFLS) regional Reliability Standard establishes more stringent and specific NPCC UFLS program requirements than the NERC continent-wide PRC-006 standard. The program is designed such that declining frequency is arrested and recovered in accordance with established NPCC performance requirements stipulated in this document. |
| PRC-010 | Undervoltage Load Shedding | To establish an integrated and coordinated approach to the design, evaluation, and reliable operation of Undervoltage Load Shedding Programs (UVLS Programs). |
| PRC-023 | Transmission Relay Loadability | Protective relay settings shall not limit transmission loadability; not interfere with system operators' ability to take remedial action to protect system reliability and; be set to reliably detect all fault conditions and protect the electrical network from these faults. |
| PRC-026 | Relay Performance During Stable Power Swings | To ensure that load-responsive protective relays are expected to not trip in response to stable power swings during non-Fault conditions. |
| TPL-001 | Transmission System Planning Performance Requirements | Establish Transmission system planning performance requirements within the planning horizon to develop a Bulk Electric System (BES) that will operate reliably over a broad spectrum of System conditions and following a wide range of probable Contingencies. |
| TPL-007 | Transmission System Planned Performance for Geomagnetic Disturbance Events | Establish requirements for Transmission system planned performance during geomagnetic disturbance (GMD) events. |

NPCC/NYSRC Area Transmission Reviews

The NPCC/NYSRC Area Transmission Reviews (ATRs) are performed on an annual basis to demonstrate that conformance with the performance criteria specified in NPCC Directory #1 and the NYSRC Reliability Rules. The ATR is prepared in accordance with NPCC and NYSRC procedures that require

the assessment to be performed annually, with a Comprehensive Area Transmission Review performed at least every five years. Either an Interim or an Intermediate review can be conducted between Comprehensive reviews, as appropriate. In an Interim review, the planning coordinator summarizes the changes in planned facilities and forecasted system conditions since the last Comprehensive review and assesses the impact of those changes. No new analysis are required for an Interim review. An Intermediate review covers all the elements of a Comprehensive review, but the analysis may be limited to addressing only significant issues, considering the extent of the system changes. In the ATRs, the NYISO assesses the BPTF for a period four to six years in the future (the NYISO evaluates year five of the Study Period). The most recent ATR completed by the NYISO is the 2020 Comprehensive ATR completed June 2021.⁷² This ATR included the post-RNA base case updates and found that the system conforms to the applicable NPCC Directory #1 and NYSRC Reliability Rules.

Seven assessments are required as part of each ATR.

The first assessment evaluates the steady state and dynamics transmission security. For instances where the transmission security assessments results indicate that the planned system does not meet the specified criteria, a corrective action plan is incorporated to achieve conformance. As part of the ATRs, and also for compliance with NERC FAC-013, thermal, voltage, and stability transfer limits are performed to identify the limiting constraints for power transfers. The most recent ATR found no steady state or dynamics transmission security criteria violations.

For the second assessment, steady state and dynamics analysis are conducted to evaluate the performance of the system for low probability extreme contingencies. The purpose of the extreme contingency analysis is to examine the post contingency steady state conditions, as well as stability, overload, cascading outages, and voltage collapse, to obtain an indication of system robustness and to determine the extent of any potential widespread system disturbance. In instances where the extreme contingency assessment concludes there are serious consequences, the NYISO evaluates implementing a change to design or operating practices to address the issues.

The extreme contingency analysis included in the most recent ATR concludes that the system remained stable during most events and showed no thermal overloads over short-term emergency (STE) ratings or significant voltage violations on the BPTF. For the events that did show voltage, thermal, or dynamics issues, these events were local in nature (loss of local load or reduction of location generation) and did not result in a widespread system disturbance.

⁷² <https://www.nyiso.com/documents/20142/1397660/2020-Comprehensive-Area-Transmission-Review.pdf/>

The third assessment evaluates extreme system conditions that have a low probability of occurrence such as high peakload conditions (*e.g.*, 90th percentile load) resulting from extreme weather or the loss of fuel supply from a given resource (*e.g.*, loss of all gas units under winter peak load). The extreme system conditions evaluate various design criteria contingencies to evaluate the post contingency steady state conditions, as well as stability, overload, cascading outages and voltage collapse. The evaluation of extreme contingencies indicates system robustness and determine the extent of any potential widespread system disturbance. In instances where the extreme contingency assessment concludes that there are serious consequences, the NYISO evaluates implementing a change to design or operating practices to address the issues. For both the high peakload and loss of gas supply conditions evaluated in the most recent ATR, the steady state analysis results indicate that these system conditions do not cause thermal or voltage violations on the BPTF. For the loss of gas case, the stability analysis results show that most contingencies are stable and damped. However, the evaluation concluded that about 400 MVAR of dynamic reactive capability near the Oswego Complex would be needed to meet dynamics reliability criteria.

The fourth assessment evaluates the breaker fault duty at BPTF buses. The most recent ATR found no over-dutied breakers on BPTF buses.

The fifth assessment evaluates other requirements specific to the NYSRC Reliability Rules including an evaluation of the impacts of planned system expansion or configuration facilities on the NYCA System Restoration Plan and Local Area Operation Rules for New York City Operations, loss of gas supply – New York City, and loss of gas supply – Long Island.

The sixth assessment is a review of Special Protection Systems (SPSs). This review evaluates the designed operation and possible consequences of failure to operate or mis-operation of the SPS within the NYCA.

The seventh assessment is a review of requested exclusions to the NPCC Directory #1 criteria.

NERC Planning Assessments (TPL-001)

The NERC TPL-001 assessment (Planning Assessment) is performed annually. The purpose of the Planning Assessment is to demonstrate conformance with the applicable NERC transmission system planning performance requirements for the NYCA Bulk Electric System (BES). The Planning Assessment is a coordinated study between the NYISO and New York Transmission Owners.

The required system conditions to evaluate for this assessment include planned system representations over a 10-year study period for a variety of system conditions. Figure 5, [below](#), provides a description of the steady state, dynamics, and short circuit cases required to be evaluated in the Planning

Assessment.

Figure 106: Description of NERC TPL-001 Planning Assessment Study Cases

| Case Description | Steady State | Dynamics | Short Circuit |
|---|--------------|----------------|---------------|
| System Peak Load (Year 1 or 2) | x | | |
| System Peak Load (Year 5) | x | x | x |
| System Peak Load (Year 10) | x | x ¹ | |
| System Off-Peak Load (One of the 5 years) | x | x | |
| System Peak Load (Year 1 or 2) Sensitivity | x | | |
| System Peak Load (Year 5) Sensitivity | x | x | |
| System Off-Peak Load (One of the 5 years) Sensitivity | x | x | |

Notes:

- Only required to be assessed to address the impact of proposed material generation additions or changes in that timeframe.

The steady state and dynamics transmission security analyses evaluate the New York State BES to meet the applicable criteria. As part of this assessment, the unavailability of major transmission equipment with a lead time of more than a year is also assessed. The fault duty at BES buses are evaluated in the short-circuit representation. When the steady state, dynamics, or short circuit analysis indicates an inability of the system to meet the performance requirements in the standard, a corrective action plan is developed addressing how the performance requirements will be met. Corrective action plans are reviewed in subsequent Planning Assessments for continued validity and implementation status.

For each steady state and dynamics case, the Planning Assessment evaluates the system response to extreme contingencies. Similar to the ATR, when the Planning Assessment extreme contingency analysis concludes there is cascading caused by an extreme contingency, the NYISO evaluates possible actions designed to reduce the likelihood or mitigate the consequences and adverse impacts.

The most recent NERC Planning Assessment for compliance with TPL-001 was completed in June 2021. As this study contains Critical Energy Infrastructure Information (CEII), it is not posted on the NYISO website. Generally, the results of this study are consistent with the ATR studies. The study scope of this assessment is different from the ATR because the ATR evaluates the Bulk Power Transmission Facilities (BPTF), while the TPL evaluates the Bulk Electric System (BES). Accordingly, criteria violations were observed on the BES. The corrective action plans for criteria violations are generally addressed in the affected Transmission Owner's Local Transmission Plan (LTP) and/or the proposed transmission facilities

listed in Section 7 of the Load and Capacity Data Report.

Resource Adequacy Compliance Efforts

NPCC's [Directory 1](#) defines a compliance obligation for the NYISO, as Resource Planner and Planning Coordinator, to perform a resource adequacy study evaluating a five-year planning horizon. The NYISO delivers a report every year under this study process to verify the system against the one-day-in-ten-years loss of load expectation (LOLE) criterion, usually based on the latest available RNA/CRP results and assumptions. The New York Area Review of Resource Adequacy completed reports are available at: <https://www.nyiso.com/planning-reliability-compliance>.

NYSRC [Reliability Rules](#) have recently added a requirement⁷³ that the NYISO deliver a Long Term Resource Adequacy Assessment report every RNA year, and an annual update in the non-RNA years. The NYISO first implemented this requirement after finalizing the 2020 RNA.

The NYISO is also actively involved in other activities such as the NERC's annual Long Term Reliability Assessment ([LTRA](#)), along with its biennial Probabilistic Assessment (ProbA), performed by NERC with the input from all the NERC Regions and Areas, as well as NPCC's Long Range Adequacy Overview ([LROA](#)).

⁷³ NYSRC Reliability Rule A.3, R.3.

Appendix I - Bulk Power Transmission Facilities

Existing New York State Bulk Power Transmission Facilities

| Facility Identifier | Terminal A | Nominal Voltage | Terminal B | Nominal Voltage |
|---------------------|------------------|-----------------|--------------------|-----------------|
| MSC-7040 | Chateauguay (HQ) | 765 | Massena | 765 |
| BK 1 | Marcy | 765 | Marcy | 345 |
| BK 2 | Marcy | 765 | Marcy | 345 |
| BK 1 | Massena | 765 | Massena (MMS1) | 230 |
| BK 2 | Massena | 765 | Massena (MMS2) | 230 |
| MSU1 | Massena | 765 | Marcy | 765 |
| 5018 | Branchburg | 500 | Ramapo | 500 |
| BK 1500 | Ramapo | 500 | Ramapo | 345 |
| M29 | Academy | 345 | Sprain Brook | 345 |
| 2 | Alps | 345 | New Scotland | 345 |
| 393 | Alps | 345 | Berkshire (ISO-NE) | 345 |
| 1-AR | Alps | 345 | Reynolds Road | 345 |
| Q35L | Astoria | 345 | E. 13th St C | 345 |
| Q35M | Astoria | 345 | E. 13th St D | 345 |
| G13 | Astoria Annex | 345 | Astoria Energy | 345 |
| PAR-1 | Astoria Annex | 345 | Astoria Annex | 345 |
| TR-1 | Astoria Annex | 345 | Astoria Annex | 138 |
| 91 | Athens | 345 | Pleasant Valley | 345 |
| 95 | Athens | 345 | Leeds | 345 |
| CC1 | Athens | 345 | Athens CC/ST #1 | 18 |
| CC2 | Athens | 345 | Athens CC/ST #2 | 18 |
| CC3 | Athens | 345 | Athens CC/ST #3 | 18 |
| G27 | Bayonne | 345 | Gowanus | 345 |
| PA301 | Beck (IESO) A | 345 | Niagara | 345 |
| PA302 | Beck (IESO) B | 345 | Niagara | 345 |
| 68 | Bowline | 345 | Ladentown | 345 |
| 1 | Bowline Point | 345 | Bowline Point #1 | 20 |
| 2 | Bowline Point | 345 | Bowline Point #2 | 20 |
| 67-1 | Bowline Point | 345 | W. Haverstraw | 345 |
| BK TA5 | Buchanan N. | 345 | Buchanan TA5 | 138 |
| W93 | Buchanan N. | 345 | Eastview 2N | 345 |
| W95 | Buchanan N. | 345 | Indian Point #2 | 22 |
| W95 | Buchanan N. | 345 | Indian Point #2 | 345 |
| Y94 | Buchanan N. | 345 | Ramapo | 345 |
| W96 | Buchanan S. | 345 | Indian Point #3 | 22 |
| W96 | Buchanan S. | 345 | Indian Point #3 | 345 |
| W97 | Buchanan S. | 345 | Millwood | 345 |

| Facility Identifier | Terminal A | Nominal Voltage | Terminal B | Nominal Voltage |
|---------------------|-----------------|-----------------|------------------------|-----------------|
| W98 | Buchanan S. | 345 | Millwood | 345 |
| Y88 | Buchanan S. | 345 | Ladentown | 345 |
| 36 | Clarks Corners | 345 | Oakdale | 345 |
| 16893 | Clarks Corners | 345 | Lafayette | 345 |
| BK 1 | Clarks Corners | 345 | Clarks Corners | 115 |
| BK 2 | Clarks Corners | 345 | Clarks Corners | 115 |
| 6 | Clay | 345 | Volney | 345 |
| 8 | Clay | 345 | Nine Mile Point #1 | 345 |
| 13 | Clay | 345 | Dewitt | 345 |
| 26 | Clay | 345 | Independence | 345 |
| 1-16 | Clay | 345 | Edic | 345 |
| 2-15 | Clay | 345 | Edic | 345 |
| BK 1 | Clay | 345 | Clay | 115 |
| BK 2 | Clay | 345 | Clay | 115 |
| PC1 | Clay | 345 | Pannell Rd | 345 |
| PC2 | Clay | 345 | Pannell Rd | 345 |
| 33 | Coopers Corners | 345 | Fraser | 345 |
| BK 2 | Coopers Corners | 345 | Coopers Corners | 115 |
| BK 3 | Coopers Corners | 345 | Coopers Corners | 115 |
| CCDA42 | Coopers Corners | 345 | Dolson Ave | 345 |
| CCRT-34 | Coopers Corners | 345 | Rock Tavern/Middletown | 345 |
| UCC2-41 | Coopers Corners | 345 | Marcy | 345 |
| F83 | Cricket Valley | 345 | Pleasant Valley | 345 |
| F84 | Cricket Valley | 345 | Pleasant Valley | 345 |
| 398 | Cricket Valley | 345 | Long Mountain (NE) | 345 |
| MSUT-1 | Cricket Valley | 345 | Cricket Valley | 18 |
| MSUT-2 | Cricket Valley | 345 | Cricket Valley | 18 |
| MSUT-3 | Cricket Valley | 345 | Cricket Valley | 18 |
| 22 | Dewitt | 345 | Lafayette | 345 |
| BK 2 | Dewitt | 345 | Dewitt | 115 |
| DART44 | Dolson Ave | 345 | Rock Tavern | 345 |
| 501 | Duffy Ave | 345 | Newbridge Road | 345 |
| 71 | Dunwoodie | 345 | Mott Haven | 345 |
| 72 | Dunwoodie | 345 | Mott Haven | 345 |
| W73/BK S1 | Dunwoodie | 345 | Dunwoodie South | 138 |
| W74/BK N1 | Dunwoodie | 345 | Dunwoodie North | 138 |
| W75 | Dunwoodie | 345 | Sprain Brook | 345 |
| W89 | Dunwoodie | 345 | Pleasantville | 345 |
| W90 | Dunwoodie | 345 | Pleasantville | 345 |
| Y50 | Dunwoodie | 345 | Shore Road | 345 |

| Facility Identifier | Terminal A | Nominal Voltage | Terminal B | Nominal Voltage |
|---------------------|----------------|-----------------|-----------------------|-----------------|
| BK 17 | E. 13th St | 345 | E. 13th St | 69 |
| 45 | E. 13th St A | 345 | Farragut | 345 |
| BK 14 | E. 13th St A | 345 | E. 13th St | 138 |
| BK 15 | E. 13th St A | 345 | E. 13th St | 138 |
| M54 | E. 13th St A | 345 | W. 49th St. | 345 |
| 46 | E. 13th St B | 345 | Farragut | 345 |
| BK 12 | E. 13th St B | 345 | E. 13th St | 138 |
| BK 13 | E. 13th St B | 345 | E. 13th St | 138 |
| M55 | E. 13th St B | 345 | W. 49th St. | 345 |
| B47 | E. 13th St C | 345 | Farragut | 345 |
| BK 16 | E. 13th St C | 345 | E. 13th St | 138 |
| 48 | E. 13th St D | 345 | Farragut | 345 |
| BK 10 | E. 13th St D | 345 | E. 13th St | 138 |
| BK 11 | E. 13th St D | 345 | E. 13th St | 138 |
| 305 | E. Fishkill | 345 | Roseton | 345 |
| BK 1 | E. Fishkill | 345 | E. Fishkill | 115 |
| BK 2 | E. Fishkill | 345 | E. Fishkill | 115 |
| F36 | E. Fishkill | 345 | Pleasant Valley | 345 |
| F37 | E. Fishkill | 345 | Pleasant Valley | 345 |
| F38/Y86 | E. Fishkill | 345 | Wood St/Pleasantville | 345 |
| F39/Y87 | E. Fishkill | 345 | Wood St/Pleasantville | 345 |
| BK 1 | E. Garden City | 345 | E. Garden City | 138 |
| BK 2 | E. Garden City | 345 | E. Garden City | 138 |
| PAR1 | E. Garden City | 345 | E. Garden City | 345 |
| PAR2 | E. Garden City | 345 | E. Garden City | 345 |
| Y49 | E. Garden City | 345 | Sprain Brook | 345 |
| 1N* | Eastview | 345 | Eastview | 138 |
| 1S* | Eastview | 345 | Eastview | 138 |
| 2N* | Eastview | 345 | Eastview | 138 |
| 2S* | Eastview | 345 | Eastview | 138 |
| W64 | Eastview 1N | 345 | Sprain Brook | 345 |
| W99 | Eastview 1N | 345 | Millwood | 345 |
| W78 | Eastview 1S | 345 | Sprain Brook | 345 |
| W85 | Eastview 1S | 345 | Millwood | 345 |
| W79 | Eastview 2N | 345 | Sprain Brook | 345 |
| W65 | Eastview 2S | 345 | Sprain Brook | 345 |
| W82 | Eastview 2S | 345 | Millwood | 345 |
| 14 | Edic | 345 | New Scotland | 345 |
| 17/BK 2 | Edic | 345 | Porter | 230 |
| BK 3 | Edic | 345 | Porter | 115 |

| Facility Identifier | Terminal A | Nominal Voltage | Terminal B | Nominal Voltage |
|---------------------|----------------|-----------------|----------------------|-----------------|
| BK 4 | Edic | 345 | Porter | 115 |
| BK 5 | Edic | 345 | Edic | 115 |
| BK 6 | Edic | 345 | Edic | 115 |
| EF24-40 | Edic | 345 | Fraser | 345 |
| FE-1 | Edic | 345 | Fitzpatrick | 345 |
| UE1-7 | Edic | 345 | Marcy | 345 |
| 17-EO | Elbridge | 345 | Oswego | 345 |
| 17-LE | Elbridge | 345 | Lafayette | 345 |
| BK 1 | Elbridge | 345 | Elbridge | 115 |
| 41 | Farragut | 345 | Gowanus | 345 |
| 42 | Farragut | 345 | Gowanus | 345 |
| 61 | Farragut | 345 | Rainey | 345 |
| 62 | Farragut | 345 | Rainey | 345 |
| 63 | Farragut | 345 | Rainey | 345 |
| B3402 | Farragut | 345 | Hudson A | 345 |
| BK 1* | Farragut | 345 | Farragut | 138 |
| BK 10 | Farragut | 345 | Farragut | 138 |
| BK 2* | Farragut | 345 | Farragut | 138 |
| BK 3* | Farragut | 345 | Farragut | 138 |
| BK 4* | Farragut | 345 | Farragut | 138 |
| BK 5* | Farragut | 345 | Farragut | 138 |
| BK 6* | Farragut | 345 | Farragut | 138 |
| BK 7* | Farragut | 345 | Farragut | 138 |
| BK 8 | Farragut | 345 | Farragut | 138 |
| BK 9 | Farragut | 345 | Farragut | 138 |
| C3403 | Farragut | 345 | Hudson B | 345 |
| TR11 | Farragut | 345 | Farragut PAR (B3402) | 345 |
| TR12 | Farragut | 345 | Farragut PAR (C3403) | 345 |
| 1 | Fitzpatrick | 345 | Fitzpatrick | 24 |
| FS-10 | Fitzpatrick | 345 | Scriba | 345 |
| BK1 | Five Mile Rd | 345 | Five Mile Rd | 115 |
| 29 | Five Mile Road | 345 | Stolle Road | 345 |
| 37 | Five Mile Road | 345 | Piercebrook | 345 |
| 32 | Fraser | 345 | Oakdale | 345 |
| BK 2 | Fraser | 345 | Fraser | 115 |
| GF5-35 | Fraser | 345 | Gilboa | 345 |
| 20 | Arthur Kill #3 | 345 | Fresh Kills | 345 |
| 20/TR3 | Fresh Kills | 345 | Arthur Kill #3 | 22 |
| 21 | Fresh Kills | 345 | Goethals | 345 |
| 22 | Fresh Kills | 345 | Goethals | 345 |

| Facility Identifier | Terminal A | Nominal Voltage | Terminal B | Nominal Voltage |
|---------------------|--------------------|-----------------|-----------------------|-----------------|
| TA 1 | Fresh Kills | 345 | Fresh Kills R | 138 |
| TB 1 | Fresh Kills | 345 | Fresh Kills R | 138 |
| 1 | Gilboa | 345 | Gilboa #1 | 17 |
| 2 | Gilboa | 345 | Gilboa #2 | 17 |
| 3 | Gilboa | 345 | Gilboa #3 | 17 |
| 4 | Gilboa | 345 | Gilboa #4 | 17 |
| GL3 | Gilboa | 345 | Leeds | 345 |
| GNS-1 | Gilboa | 345 | New Scotland | 345 |
| BK 1 | Goethals | 345 | Goethals | 230/13 |
| BK 1N | Goethals | 345 | Goethals | 345 |
| G23L | Goethals | 345 | Linden Cogen | 345 |
| G23M | Goethals | 345 | Linden Cogen | 345 |
| 25 | Goethals | 345 | Gowanus | 345 |
| BK 2 | Gowanus | 345 | Gowanus | 138 |
| 26 | Goethals | 345 | Gowanus | 345 |
| BK 14 | Gowanus | 345 | Gowanus | 138 |
| 37 | Homer City | 345 | Stolle Rd | 345 |
| 47 | Homer City | 345 | Mainesburg | 345 |
| 48 | Homer City | 345 | Piercebrook | 345 |
| Y56 | Hudson HVdc | 345 | W. 49th St | 345 |
| HR1 | Henrietta (S. 255) | 345 | Rochester Station #80 | 345 |
| HR2 | Henrietta (S. 255) | 345 | Rochester Station #80 | 345 |
| 40 | Henrietta (S. 255) | 345 | Rochester Station #80 | 345 |
| BK1 | Henrietta (S. 255) | 345 | Henrietta (S. 255) | 115 |
| BK2 | Henrietta (S. 255) | 345 | Henrietta (S. 255) | 115 |
| SHI-39 | Henrietta (S. 255) | 345 | Kintigh (Somerset) | 345 |
| 301 | Hurley Ave | 345 | Leeds | 345 |
| 303 | Hurley Ave | 345 | Roseton | 345 |
| BK 1 | Hurley Ave | 345 | Hurley Ave | 115 |
| 25 | Independence | 345 | Scriba | 345 |
| 27 | Independence | 345 | Sithe Independence #1 | 18 |
| 28 | Independence | 345 | Sithe Independence #2 | 18 |
| NS1-38 | Kintigh (Somerset) | 345 | Niagara | 345 |
| 67 | Ladentown | 345 | W. Haverstraw | 345 |
| W72 | Ladentown | 345 | Ramapo | 345 |
| 92 | Leeds | 345 | Pleasant Valley | 345 |
| 93 | Leeds | 345 | New Scotland | 345 |
| 94 | Leeds | 345 | New Scotland | 345 |
| 398 | Long Mtn. (ISO-NE) | 345 | Pleasant Valley | 345 |
| 30 | Mainesburg | 345 | Watercure | 345 |

| Facility Identifier | Terminal A | Nominal Voltage | Terminal B | Nominal Voltage |
|---------------------|--------------------|-----------------|-------------------------|-----------------|
| 18 | Marcy | 345 | New Scotland | 345 |
| 19 | Marcy | 345 | Volney | 345 |
| TA 1 | Millwood | 345 | Millwood | 138 |
| TA 2 | Millwood | 345 | Millwood | 138 |
| F30/W80 | Millwood | 345 | Wood St/Pleasant Valley | 345 |
| F31/W81 | Millwood | 345 | Wood St/Pleasant Valley | 345 |
| BK 6* | Mott Haven | 345 | Mott Haven | 138 |
| BK 7* | Mott Haven | 345 | Mott Haven | 138 |
| BK 8* | Mott Haven | 345 | Mott Haven | 138 |
| BK 9* | Mott Haven | 345 | Mott Haven | 138 |
| Q11 | Mott Haven | 345 | Rainey | 345 |
| Q12 | Mott Haven | 345 | Rainey | 345 |
| BK 1 | New Scotland | 345 | New Scotland | 115 |
| BK 2 | New Scotland | 345 | New Scotland | 115 |
| BUS TIE | New Scotland | 345 | New Scotland | 345 |
| BK 3 | Niagara | 345 | Niagara | 230 |
| BK 4 | Niagara | 345 | Niagara | 230 |
| BK 5 | Niagara | 345 | Niagara | 230 |
| NH2 | Niagara | 345 | Henrietta (S. 255) | 345 |
| 2 | Nine Mile Point | 345 | Nine Mile Point #1 | 23 |
| 9 | Nine Mile Point | 345 | Scriba | 345 |
| 23 | Nine Mile Point #2 | 345 | Scriba | 345 |
| 31 | Oakdale | 345 | Watercure | 345 |
| BK 2 | Oakdale | 345 | Oakdale | 115/34.5 |
| BK 3 | Oakdale | 345 | Oakdale | 115 |
| 5 | Oswego | 345 | Oswego #5 | 22 |
| 6 | Oswego | 345 | Oswego #6 | 22 |
| 11 | Oswego | 345 | Volney | 345 |
| 12 | Oswego | 345 | Volney | 345 |
| BK 7 | Oswego | 345 | Oswego | 115 |
| BK 1 | Pannell Road | 345 | Pannell Road | 115 |
| BK 2 | Pannell Road | 345 | Pannell Road | 115 |
| BK 3 | Pannell Road | 345 | Pannell Road | 115 |
| RP1 | Pannell Road | 345 | Rochester Station #80 | 345 |
| RP2 | Pannell Road | 345 | Rochester Station #80 | 345 |
| BK S1 | Pleasant Valley | 345 | Pleasant Valley | 115 |
| F30 | Pleasant Valley | 345 | Wood St. | 345 |
| F31 | Pleasant Valley | 345 | Wood St. | 345 |
| BK 1 | Pleasantville | 345 | Pleasantville | 13 |
| BK 2 | Pleasantville | 345 | Pleasantville | 13 |

| Facility Identifier | Terminal A | Nominal Voltage | Terminal B | Nominal Voltage |
|---------------------|-----------------------|-----------------|-----------------------|-----------------|
| Y86 | Pleasantville | 345 | Wood St. | 345 |
| Y87 | Pleasantville | 345 | Wood St. | 345 |
| TR5E/PAR5 | Rainey | 345 | Corona | 138 |
| 30 | Rainey | 345 | Ravenswood #3 | 22 |
| 60L | Rainey | 345 | Ravenswood | 345 |
| 60M | Rainey | 345 | Ravenswood | 345 |
| BK 2E* | Rainey | 345 | Rainey | 138 |
| BK 3W* | Rainey | 345 | Rainey | 138 |
| BK 7E* | Rainey | 345 | Rainey | 138 |
| BK 7W* | Rainey | 345 | Rainey | 138 |
| BK 8E | Rainey | 345 | Rainey | 138 |
| BK 8W* | Rainey | 345 | Rainey | 138 |
| BK 9E* | Rainey | 345 | Rainey | 138 |
| 69 | Ramapo | 345 | S. Mahwah A | 345 |
| 70 | Ramapo | 345 | S. Mahwah B | 345 |
| 76 | Ramapo | 345 | Sugarloaf/Rock Tavern | 345 |
| 77 | Ramapo | 345 | Rock Tavern | 345 |
| PAR3500 | Ramapo | 345 | Ramapo | 345 |
| PAR4500 | Ramapo | 345 | Ramapo | 345 |
| BK 2 | Reynolds Road | 345 | Reynolds Road | 115 |
| BK 1 | Rochester Station #80 | 345 | Rochester Station #80 | 115 |
| BK 2 | Rochester Station #80 | 345 | Rochester Station #80 | 115 |
| BK 3 | Rochester Station #80 | 345 | Rochester Station #80 | 115 |
| BK 5 | Rochester Station #80 | 345 | Rochester Station #80 | 115 |
| 311 | Rock Tavern | 345 | Roseton | 345 |
| BK TR1 | Rock Tavern | 345 | Rock Tavern | 115 |
| BK TR3 | Rock Tavern | 345 | Rock Tavern | 115 |
| 1 | Roseton | 345 | Roseton #1 | 20 |
| 2 | Roseton | 345 | Roseton #2 | 20 |
| BK 258 | S. Mahwah | 345 | S. Mahwah | 138 |
| J3410 | S. Mahwah A | 345 | Waldwick | 345 |
| K3411 | S. Mahwah B | 345 | Waldwick | 345 |
| 20 | Scriba | 345 | Volney | 345 |
| 21 | Scriba | 345 | Volney | 345 |
| BK 1 | Scriba | 345 | Scriba | 115 |
| BK 2 | Scriba | 345 | Scriba | 115 |
| 1 | Kintigh (Somerset) | 345 | Somerset | 24 |
| BK 1 | Shore Road | 345 | Shore Road | 138 |
| BK 2 | Shore Road | 345 | Shore Road | 138 |
| BK N7 | Sprain Brook | 345 | Sprain Brook | 138 |

| Facility Identifier | Terminal A | Nominal Voltage | Terminal B | Nominal Voltage |
|---------------------|-----------------|-----------------|-----------------|-----------------|
| BK S6 | Sprain Brook | 345 | Sprain Brook | 138 |
| M51 | Sprain Brook | 345 | W. 49th St | 345 |
| M52 | Sprain Brook | 345 | W. 49th St | 345 |
| X28 | Sprain Brook | 345 | Tremont | 345 |
| BK 3 | Stolle Road | 345 | Stolle Road | 115 |
| BK 4 | Stolle Road | 345 | Stolle Road | 115 |
| 11 | Tremont | 345 | Tremont | 138 |
| 12 | Tremont | 345 | Tremont | 138 |
| BK 1 | W. 49th St | 345 | W. 49th St | 138 |
| BK 2* | W. 49th St | 345 | W. 49th St | 138 |
| BK 3* | W. 49th St | 345 | W. 49th St | 138 |
| BK 4* | W. 49th St | 345 | W. 49th St | 138 |
| BK 5* | W. 49th St | 345 | W. 49th St | 138 |
| Y56 | W. 49th St | 345 | Hudson HVdc | 345 |
| BK 194 | West Haverstraw | 345 | West Haverstraw | 138 |
| BK 1 | Watercure | 345 | Watercure | 230 |
| BK 2 | Watercure | 345 | Watercure | 230 |
| BK 1 | Wood Street | 345 | Wood Street | 115 |
| BK 2 | Wood Street | 345 | Wood Street | 115 |
| 13 | Adirondack | 230 | Chases Lake | 230 |
| 12-AP | Adirondack | 230 | Porter | 230 |
| MA1 | Adirondack | 230 | Moses | 230 |
| MA2 | Adirondack | 230 | Moses | 230 |
| E205W | Bear Swamp (NE) | 230 | Eastover Rd. | 230 |
| BP76 | Beck (IESO) | 230 | Packard | 230 |
| PA27 | Beck (IESO) | 230 | Niagara | 230 |
| 60 | Canandaigua | 230 | Meyer | 230 |
| 68 | Canandaigua | 230 | Stoney Ridge | 230 |
| 11 | Chases Lake | 230 | Porter | 230 |
| DP1 | Duley | 230 | Plattsburgh | 230 |
| PND-1 | Duley | 230 | Patnode | 230 |
| 68 | Dunkirk | 230 | S. Ripley | 230 |
| 73 | Dunkirk | 230 | Gardenville | 230 |
| 74 | Dunkirk | 230 | Gardenville | 230 |
| 70 | E.Towanda | 230 | Hillside | 230 |
| 38 | Eastover Rd. | 230 | Rotterdam | 230 |
| TB 1 | Eastover Rd. | 230 | Eastover Rd. | 115 |
| TB 2 | Eastover Rd. | 230 | Eastover Rd. | 115 |
| 17 | Edic | 230 | Porter | 230 |
| 70 | Elm St | 230 | Huntley | 230 |

| Facility Identifier | Terminal A | Nominal Voltage | Terminal B | Nominal Voltage |
|---------------------|---------------------|-----------------|---------------------|-----------------|
| 71 | Elm St | 230 | Gardenville | 230 |
| 72 | Elm St | 230 | Gardenville | 230 |
| 69 | Erie East (PJM) | 230 | S. Ripley | 230 |
| 66 | Gardenville | 230 | Stolle Rd | 230 |
| 79 | Gardenville | 230 | Huntley | 230 |
| 80 | Gardenville | 230 | Huntley | 230 |
| BK 2 | Gardenville | 230 | Gardenville | 115 |
| BK 3 | Gardenville | 230 | Gardenville | 115 |
| BK 4 | Gardenville | 230 | Gardenville | 115 |
| BK 6 | Gardenville | 230 | Gardenville | 115/34.5 |
| BK 7 | Gardenville | 230 | Gardenville | 115/34.5 |
| T8-12 | Gardenville (NGrid) | 230 | Gardenville (NYSEG) | 230 |
| A2253 | Goethals | 230 | Linden (PJM) | 230 |
| 67 | High Sheldon | 230 | Stolle Rd | 230 |
| 81 | High Sheldon | 230 | Stoney Creek | 230 |
| 69 | Hillside | 230 | Watercure | 230 |
| 72 | Hillside | 230 | Stoney Ridge | 230 |
| BK 3 | Hillside | 230 | Hillside | 115/34.5 |
| BK 4 | Hillside | 230 | Hillside | 115/34.5 |
| 77 | Huntley | 230 | Packard | 230 |
| BK 670 | Huntley | 230 | Huntley #67 | 13 |
| BK 680 | Huntley | 230 | Huntley #68 | 13 |
| 78 | Huntley | 230 | Packard | 230 |
| MMS1 | Massena | 230 | Moses | 230 |
| MMS2 | Massena | 230 | Moses | 230 |
| 85/87 | Meyer | 230 | Wethersfield | 230 |
| BK 4 | Meyer | 230 | Meyer | 115/34.5 |
| BK 1 | Moses | 230 | Moses | 115 |
| BK 2 | Moses | 230 | Moses | 115 |
| BK 3 | Moses | 230 | Moses | 115 |
| BK 4 | Moses | 230 | Moses | 115 |
| L33P | Moses | 230 | St. Lawrence (IESO) | 230 |
| L34P | Moses | 230 | St. Lawrence (IESO) | 230 |
| MW1 | Moses | 230 | Willis | 230 |
| MW2 | Moses | 230 | Willis | 230 |
| 61 | Niagara | 230 | Packard | 230 |
| 62 | Niagara | 230 | Packard | 230 |
| 64 | Niagara | 230 | Robinson Rd | 230 |
| 2332 | Niagara | 230 | Niagara | 230 |
| 2342 | Niagara | 230 | Niagara | 230 |

| Facility Identifier | Terminal A | Nominal Voltage | Terminal B | Nominal Voltage |
|---------------------|---------------|-----------------|----------------|-----------------|
| BK T1 | Niagara | 230 | Niagara | 115 |
| BK T2 | Niagara | 230 | Niagara | 115 |
| N Bus Tie | Niagara | 230 | Niagara | 230 |
| S Bus Tie | Niagara | 230 | Niagara | 230 |
| 71 | Oakdale | 230 | Watercure | 230 |
| BK 1 | Oakdale | 230 | Oakdale | 115 |
| 3 | Packard | 230 | Packard | 115 |
| 4 | Packard | 230 | Packard | 115 |
| WPN1 | Patnode | 230 | Willis | 230 |
| BK 1 | Plattsburgh | 230 | Plattsburgh | 115 |
| BK 4 | Plattsburgh | 230 | Plattsburgh | 115 |
| RYP-2 | Plattsburgh | 230 | Ryan | 230 |
| 30 | Porter | 230 | Rotterdam | 230 |
| 31 | Porter | 230 | Rotterdam | 230 |
| BK 1 | Porter | 230 | Porter | 115 |
| BK 2 | Porter | 230 | Porter | 115 |
| 65 | Robinson Road | 230 | Stolle Road | 230 |
| BK 1 | Robinson Road | 230 | Robinson Road | 115/34.5 |
| WRY-2 | Ryan | 230 | Willis | 230 |
| 83 | Stony Creek | 230 | Wethersfield | 230 |
| BK 1 | Academy 1 | 138 | Academy 1 | 138 |
| BK 8 | Academy 8 | 138 | Academy 8 | 138 |
| 34124L&M | Astoria E | 138 | Astoria #4 | 138 |
| 34125L&M | Astoria E | 138 | Astoria #5 | 138 |
| 24121 | Astoria W | 138 | Astoria #3 | 138 |
| 24122 | Astoria W | 138 | Astoria #3 | 138 |
| 24124L&M | Astoria W | 138 | Astoria #4 | 138 |
| 24125L&M | Astoria W | 138 | Astoria #5 | 138 |
| 563 | Bagatelle Rd. | 138 | Newbridge Road | 138 |
| 564 | Bagatelle Rd. | 138 | Pilgrim | 138 |
| 291 | Barrett | 138 | Valley Stream | 138 |
| 292 | Barrett | 138 | Valley Stream | 138 |
| 459 | Barrett | 138 | Freeport | 138 |
| PAR | Barrett | 138 | Barrett PAR | 138 |
| 861 | Brookhaven | 138 | Wildwood | 138 |
| 864 | Brookhaven | 138 | Edward Ave | 138 |
| 874 | Brookhaven | 138 | Sills Road | 138 |
| 887 | Brookhaven | 138 | Sills Road | 138 |
| 95891 | Buchanan GT | 138 | Buchanan TA5 | 138 |
| 361 | Carle Place | 138 | E. Garden City | 138 |

| Facility Identifier | Terminal A | Nominal Voltage | Terminal B | Nominal Voltage |
|---------------------|------------------|-----------------|-------------------|-----------------|
| 363 | Carle Place | 138 | Glenwood | 138 |
| 883 | Central Islip | 138 | Ronkonkoma | 138 |
| 889 | Central Islip | 138 | Hauppauge | 138 |
| BK N1 | Dunwoodie | 138 | Dunwoodie | 138 |
| BK N2 | Dunwoodie | 138 | Dunwoodie | 138 |
| BK S1 | Dunwoodie | 138 | Dunwoodie | 138 |
| BK S2 | Dunwoodie | 138 | Dunwoodie | 138 |
| 262 | E. Garden City | 138 | Valley Stream | 138 |
| 261 | E. Garden City | 138 | Valley Stream | 138 |
| 362 | E. Garden City | 138 | Roslyn | 138 |
| 462 | E. Garden City | 138 | Newbridge Road | 138 |
| 463 | E. Garden City | 138 | Newbridge Road | 138 |
| 465 | E. Garden City | 138 | Newbridge Road | 138 |
| 467 | E. Garden City | 138 | Newbridge Road | 138 |
| 893 | Edward Ave | 138 | Riverhead | 138 |
| 673 | Elwood | 138 | Greenlawn | 138 |
| 674 | Elwood | 138 | Oakwood | 138 |
| 678 | Elwood | 138 | Northport | 138 |
| 681 | Elwood | 138 | Northport | 138 |
| 461 | Freeport | 138 | Newbridge Road | 138 |
| PAR1 | Fresh Kills (AK) | 138 | Fresh Kills PAR | 138 |
| PAR2 | Fresh Kills (AK) | 138 | Fresh Kills PAR | 138 |
| 365 | Glenwood | 138 | Shore Road | 138 |
| 366-1 | Glenwood | 138 | Shore Road | 138 |
| 366-2 | Glenwood | 138 | Glenwood GT | 138 |
| 364 | Glenwood GT | 138 | Roslyn | 138 |
| 676 | Greenlawn | 138 | Syosset | 138 |
| 871 | Hauppauge | 138 | Pilgrim | 138 |
| 872 | Holbrook | 138 | Sills Road | 138 |
| 884 | Holbrook | 138 | North Shore Beach | 138 |
| 885 | Holbrook | 138 | Miller Place | 138 |
| 888 | Holbrook | 138 | West Bus | 138 |
| 862 | Holbrook | 138 | Port Jefferson | 138 |
| 875 | Holbrook | 138 | Ronkonkoma | 138 |
| 882 | Holbrook | 138 | Ruland Road | 138 |
| 886 | Holbrook | 138 | Port Jefferson | 138 |
| 818 | Holtsville | 138 | Union Ave | 138 |
| 876 | Holtsville | 138 | West Bus | 138 |
| 877 | Holtsville | 138 | West Bus | 138 |
| 903 | Jamaica | 138 | Lake Success | 138 |

| Facility Identifier | Terminal A | Nominal Voltage | Terminal B | Nominal Voltage |
|----------------------|-------------------|-----------------|------------------|-----------------|
| 901 L&M | Jamaica | 138 | Valley Stream | 138 |
| 367 | Lake Success | 138 | Shore Road | 138 |
| 368 | Lake Success | 138 | Shore Road | 138 |
| PAR | Lake Success | 138 | Lake Success PAR | 138 |
| 558 | Locust Grove | 138 | Newbridge | 138 |
| 559 | Locust Grove | 138 | Syosset | 138 |
| 879 | Miller Place | 138 | Shoreham | 138 |
| 561 | Newbridge Road | 138 | Ruland Road | 138 |
| 562 | Newbridge Road | 138 | Ruland Road | 138 |
| 567 | Newbridge Road | 138 | Ruland Road | 138 |
| 878 | North Shore Beach | 138 | Wading River | 138 |
| 1 | Northport | 138 | Northport #1 | 22 |
| 2 | Northport | 138 | Northport #2 | 22 |
| 3 | Northport | 138 | Northport #3 | 22 |
| 4 | Northport | 138 | Northport #4 | 22 |
| 672 | Northport | 138 | Pilgrim | 138 |
| 677 | Northport | 138 | Pilgrim | 138 |
| 679 | Northport | 138 | Pilgrim | 138 |
| 1385 (601, 602, 603) | Northport | 138 | Norwalk Harbor | 138 |
| PAR 1 | Northport | 138 | Northport | 138 |
| PS2 | Northport | 138 | Northport | 138 |
| 675 | Oakwood | 138 | Syosset | 138 |
| 661 | Pilgrim | 138 | Ruland Road | 138 |
| 662 | Pilgrim | 138 | Ruland Road | 138 |
| 881 | Pilgrim | 138 | West Bus | 138 |
| PAR | Pilgrim | 138 | Pilgrim PAR | 138 |
| 36311 | Rainey | 138 | Vernon | 138 |
| 36312 | Rainey | 138 | Vernon | 138 |
| 890 | Riverhead | 138 | Wildwood | 138 |
| 863 | Shoreham | 138 | Wildwood | 138 |
| 867 | Shoreham | 138 | Wildwood | 138 |
| 891 | Shoreham | 138 | Wading River | 138 |
| 873 | Sills Road | 138 | West Bus | 138 |
| PAR11 | Tremont | 138 | Tremont PAR 11 | 138 |
| PAR12 | Tremont | 138 | Tremont PAR 12 | 138 |
| PAR | Valley Stream | 138 | Valley Stream | 138 |
| 10 | Vernon | 138 | Ravenswood #1 | 20 |
| 20 | Vernon | 138 | Ravenswood #2 | 20 |
| 1-BP | Boonville | 115 | Porter | 115 |
| 2-BP | Boonville | 115 | Porter | 115 |

| Facility Identifier | Terminal A | Nominal Voltage | Terminal B | Nominal Voltage |
|---------------------|-------------|-----------------|-----------------|-----------------|
| 3 | Clay | 115 | Dewitt | 115 |
| 4 | Clay | 115 | South Oswego | 115 |
| 5 | Clay | 115 | Dewitt | 115 |
| 10 | Clay | 115 | Teall Ave. | 115 |
| 11 | Clay | 115 | Teall Ave. | 115 |
| 14 | Clay | 115 | Lockheed (GE) | 115 |
| 17 | Clay | 115 | Woodard | 115 |
| 7-CL | Clay | 115 | Lighthouse Hill | 115 |
| 8 | Deerfield | 115 | Porter | 115 |
| 9 | Deerfield | 115 | Porter | 115 |
| 20 | Edic | 115 | Porter | 115 |
| 1 | Ginna | 115 | Ginna | 16 |
| 912 | Ginna | 115 | Pannell Rd. | 115 |
| 908-1 | Ginna | 115 | Pannell Rd. | 115 |
| 7X8272 | Mortimer | 115 | Sta#82 | 115 |
| 7 | Oneida | 115 | Porter | 115 |
| PAR3 | Plattsburgh | 115 | Plattsburgh | 115 |
| PV20 | Plattsburgh | 115 | South Hero | 115 |
| 3 | Porter | 115 | Yahundasis | 115 |
| 4 | Porter | 115 | Valley | 115 |
| 5 | Porter | 115 | Watkins Rd. | 115 |
| 6 | Porter | 115 | Terminal | 115 |
| 13 | Porter | 115 | Schuyler | 115 |
| 10 | Edic | 115 | Porter | 115 |

New York Control Area Proposed Bulk Power Transmission Facilities List

| Transmission Owner | Terminals | | Expected In-Service | | Nominal Voltage in kV | | # of Circuits | Thermal Ratings | |
|--------------------------------|-----------------------------|---------------------------|---------------------|------|-----------------------|---------|---------------|-----------------|----------|
| | From | To | Prior To | Year | Operating | Design | | Summer | Winter |
| | | | | | | | | | |
| ConEd | Rainey | Corona | S | 2023 | 345/138 | 345/138 | | N/A | N/A |
| ConEd | Cricket Valley | Dover (New Station) | W | 2023 | 345 | 345 | 1 | 2220 | 2700 |
| ConEd | Dover (New Station) | CT State Line | W | 2023 | 345 | 345 | 1 | 2220 | 2700 |
| ConEd | Gowanus | Greenwood | S | 2025 | 345/138 | 345/138 | | N/A | N/A |
| ConEd | Goethals | Fox Hills | S | 2025 | 345/138 | 345/138 | | N/A | N/A |
| LIPA | Riverhead | Wildwood | S | 2021 | 138 | 138 | 1 | 1399 | 1709 |
| LSP | Gordon Rd (New Station) | Rotterdam | S | 2022 | 345/230 | 345/230 | 2 | 478 MVA | 478 MVA |
| LSP | Gordon Rd (New Station) | Princeton (New Station) | S | 2023 | 345 | 345 | 1 | 3410 | 3709 |
| LSP | Princeton (New Station) | New Scotland | S | 2023 | 345 | 345 | 2 | 3410 | 3709 |
| LSP | Gordon Rd (New Station) | Gordon Rd (New Station) | S | 2029 | 345/230 | 345/230 | 1 | 478 MVA | 478 MVA |
| LSP | Gordon Rd (New Station) | Rotterdam | S | 2029 | 345/115 | 345/115 | 2 | 650 MVA | 650 MVA |
| LSP/NGRID | Edic | Gordon Rd (New Station) | S | 2022 | 345 | 345 | 1 | 2228 | 2718 |
| LSP/NGRID | Gordon Rd (New Station) | New Scotland | S | 2022 | 345 | 345 | 1 | 2228 | 2718 |
| LSP/NGRID | Princeton (New Station) | New Scotland | S | 2023 | 345 | 345 | 1 | 2228 | 2718 |
| LSP/NYPA/NGRID | Edic | Princeton (New Station) | W | 2023 | 345 | 345 | 2 | 3410 | 3709 |
| New York Transco | Knickerbocker (New Station) | Pleasant Valley | W | 2023 | 345 | 345 | 1 | 3862 | 4103 |
| New York Transco/Con Ed | Van Wagner (New Station) | Pleasant Valley | W | 2023 | 345 | 345 | 1 | 3126 | 3704 |
| New York Transco/Con Ed | Van Wagner (New Station) | Pleasant Valley | W | 2023 | 345 | 345 | 1 | 3126 | 3704 |
| NextEra Energy Transmission NY | Dysinger (New Station) | East Stolle (New Station) | S | 2022 | 345 | 345 | 1 | 1356 MVA | 1612 MVA |
| NextEra Energy Transmission NY | Dysinger (New Station) | Dysinger (New Station) | S | 2022 | 345 | 345 | 1 | 700 MVA | 700 MVA |
| NGRID | Knickerbocker (New Station) | New Scotland | W | 2023 | 345 | 345 | 1 | 2381 | 3099 |

| Transmission Owner | Terminals | | Expected In-Service | | Nominal Voltage in kV | | # of Circuits | Thermal Ratings | |
|--------------------|-------------------------------------|-------------------------------------|---------------------|------|-----------------------|--------------|---------------|-----------------|---------|
| | From | To | Prior To | Year | Operating | Design | | Summer | Winter |
| NGRID | Knickerbocker (New Station) | Alps | W | 2023 | 345 | 345 | 1 | 2552 | 3134 |
| NGRID | Athens | Van Wagner (New Station) | W | 2023 | 345 | 345 | 1 | 2228 | 2718 |
| NGRID | Leeds | Van Wagner (New Station) | W | 2023 | 345 | 345 | 1 | 2228 | 2718 |
| NGRID | Gordon Rd (New Station) | Eastover Rd | S | 2029 | 230 | 230 | 1 | 1114 | 1284 |
| NYSEG | Wood Street | Wood Street | W | 2022 | 345/115 | 345/115 | 1 | 327 MVA | 378 MVA |
| NYSEG | Fraser | Fraser | S | 2024 | 345/115 | 345/115 | 1 | 305 MVA | 364 MVA |
| NYSEG | Gardenville | Gardenville | S | 2026 | 230/115 | 230/115 | 1 | 316 MVA | 370 MVA |
| NYSEG | South Perry | South Perry | S | 2027 | 230/115 | 230/115 | 1 | 246 MVA | 291 MVA |
| NYSEG | Oakdale 345 | Oakdale 115 | S | 2027 | 345/115 | 345/115/34.5 | 1 | 494MVA | 527 MVA |
| NYSEG | Coopers Corners | Coopers Corners | S | 2031 | 345/115 | 345/115 | 1 | 232 MVA | 270 MVA |
| O & R | Lovett 345 kV Station (New Station) | Lovett | S | 2023 | 345/138 | 345/138 | 1 | 562 MVA | 562 MVA |
| O & R/ConEd | Ladentown | Lovett 345 kV Station (New Station) | S | 2023 | 345 | 345 | 1 | 3000 | 3211 |
| O & R/ConEd | Lovett 345 kV Station (New Station) | Buchanan | S | 2023 | 345 | 345 | 1 | 3000 | 3211 |

