



Manual 25

Revenue Metering Requirements Manual

Issued: January 2022

Version: 3.4

Effective Date: 01/04/2022

Committee Acceptance: 12/15/2021 BIC

Prepared By: NYISO Customer Settlements

New York Independent System Operator
10 Krey Boulevard
Rensselaer, NY 12144
(518) 356-6060
www.nyiso.com

Disclaimer: The information contained within this manual, along with other NYISO manuals, is intended to be used for information purposes only, and is subject to change. The NYISO is not responsible for the user's reliance on these publications, or for any erroneous or misleading material.

©Copyright 1999-2022 New York Independent System Operator

Table of Contents

REVISION HISTORY.....	V
1. OVERVIEW	1
1.1... Background	1
1.2.Terminology/Definitions	1
2. METERING EQUIPMENT STANDARDS AND SPECIFICATIONS	3
2.1.General Requirements.....	3
2.1.1. Reliability	3
2.1.2. Accuracy.....	3
2.1.3. Documentation	4
2.2.Detailed Requirements.....	4
2.2.1. Meters.....	4
2.2.2. Instrument Transformers.....	4
2.2.3. Data Transmission Subsystem	5
3. GUIDELINES FOR THE INSTALLATION, CALIBRATION, AND MAINTENANCE OF REVENUE METERING SYSTEMS.....	6
3.1.Responsibilities	6
3.2.... Installation	6
3.2.1. Meter Configuration for Behind-the-Meter Net Generation Resources.....	7
3.2.2. Meter Configuration for Energy Storage Resources	8
3.2.3. Meter Configuration for Co-located Storage Resources (CSR).....	9
3.2.4. Zonal and Sub-zonal Tie Line Boundaries.....	10
3.3.Calibration and Maintenance	10
3.3.1. Calibration and Maintenance Standards	10
3.3.2. Calibration Documentation and Auditing	11
3.3.3. Metering System Inspection and Testing	12
4. NYISO REVENUE DATA REQUIREMENTS.....	13
4.1.Revenue Metering Data	13
4.2.Digital and Analog Telemetry	13
4.3.Meter Authority Requirements	13
4.4.Data Processing	14
4.4.1. Generator and Tie-line Meter Data Tasks.....	14
4.4.2. Tasks Concerning the Meter Authority TOL Process	14
4.4.3. NYISO Meter Data Process.....	15
4.5.Metering Improvement Priorities.....	15

5. DATA ANALYSIS AND DATA PROBLEM RESOLUTION	17
5.1. Metering and Data Accuracy Analysis.....	17
5.1.1. <i>Responsibilities</i>	17
5.1.2. <i>Procedure</i>	17
5.1.3. <i>Reporting</i>	17
5.2. Loss of Metering Data.....	18
5.3. Procedures for Dispute Resolution of Data Issues	18
5.4. Further Actions	18

Revision History

Version	Date	Revisions
1.0	07/28/2005	Initial Release
1.0	09/03/2013	Recertification
2.0	12/13/2016	<p>Global</p> <ul style="list-style-type: none"> ➤ Reformatted to new template. ➤ Implemented minor stylistic changes. ➤ Updated links to documents on NYISO website. ➤ Updated citations to the Web-Based Reconciliation System to instead read Settlement Data Exchange (SDX). <p>Revision History Table</p> <ul style="list-style-type: none"> ➤ Changed column headings as follows: <ul style="list-style-type: none"> • “Revision” changed to “Version”; • “Changes” changed to “Revisions.” ➤ Modified Initial Release entry to specify the version as “1.0”. <p>Section 1.1</p> <ul style="list-style-type: none"> ➤ Deleted: "Current metering technology (as of November 1999) in operation for the NYISO [formerly the New York Power Pool (NYPP)], Transmission Owners (TOs), Eligible Customers, and other applicable Participants, although it may not conform to these requirements,". <p>Section 1.2</p> <ul style="list-style-type: none"> ➤ Refined definitions as necessary to improve clarity. <p>Section 3.1</p> <ul style="list-style-type: none"> ➤ Eliminated text limiting responsibility for the costs associated with purchase, installation, and appropriate maintenance of meters, wiring, communications equipment, and all components essential to their accurate and reliable operation to just those Market Participants that are not retail energy customers. <p>Section 3.3.2</p> <ul style="list-style-type: none"> ➤ Changed "are to" to "shall." ➤ Inserted reference to Market Administration and Control Area Services Tariff Article 10. <p>Section 4.4.1</p> <ul style="list-style-type: none"> ➤ Modified Final Bill Closeout language.
2.0	03/11/2019	Recertified
3.0	09/27/2019	<p>Section 1.2</p> <ul style="list-style-type: none"> ➤ Added and refined definitions to include Member Systems and Meter Services Entity. <p>Section 2.2.3</p>

		<ul style="list-style-type: none"> ➤ Updated citations to SDX User's Guide to read Settlement Data Applications User's Guide. <p>Section 4.3</p> <ul style="list-style-type: none"> ➤ Deleted references to MSP and MDSP <p>Section 4.4.3</p> <ul style="list-style-type: none"> ➤ Updated citations to the Tie_Gen_TOL_Status to read Hourly Tie-line, Generator, and LSE Bus Meter Data Review, Revision, & Lock-down Schedule <p>Section 5.1.1</p> <ul style="list-style-type: none"> ➤ Modified working group name
3.1	03/31/2020	<p>Global Branding</p> <ul style="list-style-type: none"> ➤ Updated the logos and formatting <p>Section 2.1.3</p> <ul style="list-style-type: none"> ➤ Addition of Member System responsibility for meter inventory related information. <p>Section 3.2</p> <ul style="list-style-type: none"> ➤ Created meter configuration sub-section 3.2.1 for BTM: NG and 3.2.2 for ESR. <p>Section 4.2</p> <ul style="list-style-type: none"> ➤ Addition of applicable time duration.
3.2	02/08/2021	<p>Recertification</p> <p>Section 1.2</p> <ul style="list-style-type: none"> ➤ Modified terminology/definition of Meter Services Entity (MSE) to include Demand Reduction Providers and DSASP Providers as Market Participants who can utilize MSEs.
3.3	10/28/2021	<p>Recertification</p> <p>Section 3.2</p> <ul style="list-style-type: none"> ➤ Created meter configuration sub-section 3.2.3 for CSR.
3.4	01/04/2022	<p>Section 1.2</p> <ul style="list-style-type: none"> ➤ Modified definition of Meter Authority to include municipal electric utilities.

1. Overview

The material in this manual defines the standards for the revenue metering systems required for conducting accurate financial settlements of the New York Independent System Operator, Inc.(NYISO)-administered wholesale electric energy markets. Additionally, it defines the responsibilities for Meter Authorities (MA) and describes the processes for data processing, analysis, and dispute resolution.

References for this document include the *Guide for Uniform Practices in Revenue Quality Metering* approved by the New York State Electric Meter Engineers' Committee, August 20, 2003, (available at <https://www.nyiso.com/manuals-tech-bulletins-user-guides> (expand "manuals," click "Additional Manuals")), and the NYISO *Control Center Requirements Manual* (available at <https://www.nyiso.com/manuals-tech-bulletins-user-guides> (expand "manuals," click "Administrative"))).

1.1. Background

This document applies to all metering systems, and related equipment, that are used for settlement of the NYISO markets. As provided in the NYISO-TO Agreement, “The Transmission Owner shall cooperate with the NYISO in implementing reasonable metering enhancements and new metering installations that the NYISO may deem necessary, provided that mechanisms, satisfactory to each Transmission Owner, are in place for their recovery of all associated costs.”

1.2. Terminology/Definitions

The following terms are an integral part of this manual:

- **Backup Data Sources** — An alternate data source identified for each revenue meter point, to be used when the primary source is unavailable or of insufficient quality.
- **Data Problem** — Where the quality of a data item, either telemetered or obtained by other means at a DC, is poor enough to affect the accuracy of settlements, and the cause of such poor quality has been traced to computer programming, communications limitations, computer equipment configuration, or field metering equipment.
- **Data Quality** — The measure of the reliability and accuracy of a data item.
- **Member Systems** - The eight Transmission Owners that comprised the membership of the New York Power Pool, which are: (1) Central Hudson Gas & Electric Corporation, (2) Consolidated Edison Company of New York, Inc., (3) New York State Electric & Gas Corporation, (4) Niagara Mohawk Power Corporation d/b/a National Grid, (5) Orange and Rockland Utilities, Inc., (6) Rochester Gas and Electric Corporation, (7) the Power Authority of the State of New York, and (8) Long Island Lighting Company d/b/a Long Island Power Authority.

- **Metering and Data Accuracy Analysis** — Method of monitoring the quality of data and communications procedures between parties and the NYISO can be found in [Section 5.1](#) of this manual.
- **Meter Authority ("MA")** — An entity that is responsible for the calibration, maintenance, operation, and reporting of metered data from an electric revenue meter used in the wholesale electricity markets administered by the NYISO (*i.e.*, a Member System, Meter Services Entity, or municipal electric utility).
- **Meter Services Entity ("MSE")** - An entity registered with the ISO and authorized to provide metering and meter data services, as applicable, to a Demand Reduction Provider, DSASP Provider, Aggregator, Responsible Interface Party or Curtailment Service Provider.
- **Electric Revenue Metering System** — A system that consists of an electric revenue meter and instrument transformers or transducers, that provide separate input signals to the NYISO for revenue calculations.
- **Meter Inventory** — The listing of revenue meters for which a MA is responsible.
- **Metering Problem** — Where the quality of an item of data is sufficiently poor to affect the accuracy of accounting settlements and the cause of such poor quality has been traced to installed metering equipment.
- **PTS Data** — Real-time telemetry, which is a component of the real-time settlement, and is used by the NYISO for initial billing and final settlement if no other values are available.
- **Revenue Metering Equipment** — Includes the revenue meters, current transformers, voltage transformers, test switches, transducers, remote terminal units (RTU), wiring, connecting blocks, and the cabinets/panels that house the above.
- **Revenue Quality Metering** — Use of Electric Revenue Metering Systems to provide data for energy billing purpose. The components of these systems are approved by both the TO and the New York State (NYS) Public Service Commission (PSC) for revenue settlements.
- **Revenue Quality Real-Time Metering** — An accurate metering system that satisfies American National Standards Institute (ANSI) C12 requirements for electrical energy billing purposes, approved for use by both the TO and the NYS PSC.
- **Sub-Zone** — Subregion of a New York Control Area (NYCA) Locational-Based Marginal Pricing (LBMP) zone controlled by a single transmission owner. Sub-zones are defined and metered to allow allocation of energy to load.
- **Settlement Data Exchange ("SDX")** — A web-enabled application for the upload and download query functions related to hourly tie line, generation, Sub-Zone, and load bus data.
- **Zone** — A region of the NYCA with a single LBMP.

2. Metering Equipment Standards and Specifications

The purpose of this section is to provide specifications for Revenue Metering Systems that are required to provide data for the settlement and billing of the NYISO markets. The NYISO's legacy-billing infrastructure, which was developed for the NYPP and is still in place, may continue to support the billing process, but may only meet the requirements of "backup" billing metering. Where this is the case, additional attention and monitoring will be required to maintain the accuracy of these installations until a metering installation such as one with the specifications outlined in this manual, or subsequent versions, may be installed.

Revenue metering systems that supply metering data to the NYISO for energy settlement purposes will meet the reliability and accuracy requirements outlined in this section. Components of such revenue metering systems will comply with the standards detailed in appropriate sections of the industry standards or applicable standards/policies issued by TOs. These components should include transducers, meters, RTUs, instrument transformers, power supply, and the data transmission sub-system. The installation, calibration, and maintenance of the revenue metering equipment is detailed in [Section 3](#) of this manual.

2.1. General Requirements

This section provides general requirements for revenue metering equipment.

2.1.1. Reliability

Each revenue metering system will be capable of supplying data to the NYISO in a timely, accurate, and reliable manner. In the event that such data transmission is interrupted, the responsible MA will provide back-up metering data to NYISO in a timeframe that will not delay energy settlements. The MA will restore the normal data transmission capability as promptly as possible.

2.1.2. Accuracy

Revenue quality meters should meet the accuracy requirements reflected in the *Guide for Uniform Practices in Revenue Quality Metering*. (available at <https://www.nyiso.com/manuals-tech-bulletins-user-guides> (expand "Manuals," click on "Additional Manuals")). Billing data values obtained from meters meeting this specification will be transmitted to the NYISO's Settlement Data Exchange (SDX) application with zero error.

2.1.3. Documentation

Electrical and schematic diagrams, and documentation associated with revenue metering systems and their components will be maintained by the MA in compliance with the *Guide for Uniform Practices in Revenue Quality Metering* (available at <https://www.nyiso.com/manuals-tech-bulletins-user-guides> (expand "Manuals," click on "Additional Manuals"))).

The NYISO will maintain an inventory of the type of meter installed, data collection method, and calibration status, for all revenue meters. Member Systems will provide this data to the NYISO annually. Member Systems shall provide all necessary metering equipment information to NYISO-authorized MSEs or Market Participants for the completion of the NYISO meter inventory within thirty (30) days of receipt of the request.

2.2. Detailed Requirements

This section provides detailed requirements for revenue metering equipment.

2.2.1. Meters

The meters used for MWhr meter data will be digital, true Root Mean-Squared (RMS) devices that meet or exceed ANSI C12.20 standards. Revenue meters for new installations must have the ability to record load profile data.

Revenue meters must be accessible remotely by the use of telephone dial-up or other communication technology.

Revenue meters will be configured according to the responsible MA's specifications, making note of manufacturer's recommendation as applicable. Proper compensation for line and transformer losses and for instrument transformer errors will be adjusted in the final revenue metering data. Refer to the latest edition of Edison Electric Institute's Handbook for Electricity Metering for details.

2.2.2. Instrument Transformers

All instrument transformers must:

- Be approved for revenue purpose by the NYS PSC.
- Meet or exceed ANSI standard C57.13 and all applicable ANSI C12 Series standards.

In addition,

- All Current Transformers (CT's) and Voltage Transformers (VT's) used for revenue metering purpose must conform to the ANSI standard accuracy class for metering services of 0.3 or better.

- All CT's must withstand continuous operation and maintain the above accuracy at twice or more of rated current.
- All VT's must be a wound or cascade type. Coupling Capacitor Voltage Transformers (CCVT's) are not permitted for revenue metering purpose.

2.2.3. Data Transmission Subsystem

Telemetry data that are required for the NYISO's Performance Tracking System (PTS) values will be transmitted to NYISO. The requirement associated with this data stream is specified in the NYISO *Control Center Requirements Manual* (available at <https://www.nyiso.com/manuals-tech-bulletins-user-guides>

(expand "Manuals," click "Administrative")).

Hourly MWhr data is required to be automatically uploaded to the NYISO's SDX application following the data communication requirements outlined in the NYISO *Settlement Data Applications User's Guide* (available at: <https://www.nyiso.com/manuals-tech-bulletins-user-guides>).

Each MA will have in place an alternative means of transmitting hourly MWhr data to the NYISO in the event that either of the above two data transmission processes is interrupted.

3. Guidelines for the Installation, Calibration, and Maintenance of Revenue Metering Systems

This section provides guidelines for the installation and maintenance of all equipment utilized for measuring, recording, and reporting of electrical generation, transmission, station power consumption, and other meter data to enable the NYISO to settle the markets. These guidelines apply to all Market Participants of the NYISO, including power suppliers, TOs, and load serving entities (LSEs) acting in the capacity of a MA.

These guidelines are “minimum standards” for the purposes of NYISO billing and settlements and do not preclude more stringent standards that may be required of TOs in neighboring systems.

3.1. Responsibilities

Each Market Participant is responsible for the costs associated with purchase, installation, and appropriate maintenance of meters, wiring, communications equipment, and all components essential to their accurate and reliable operation. This includes spare equipment, if applicable, in accordance with the requirements of the NYISO and the appropriate TO.

MAs are responsible for calibrating all metering for which they are responsible within the guidelines of this manual and in accordance with responsible TO requirements. The MA may allow a designated representative to perform calibration and maintenance duties, but the MA must maintain control over the metering equipment in accordance with NYS PSC rules and regulations.

3.2. Installation

Generation meters should be installed at the high side of the Generator Step-Up Transformer (GSU), whenever practical. If a generation meter must be installed at an alternate location, it will be compensated to the high side of the GSU.

To the extent that additional generation resources are added to an existing Point of Injection such that a single facility consists of multiple Generators bidding separately, additional meters with real-time telemetry may be required on the low side of the GSU.

Revenue metering system installations must ensure the accurate measurement of energy while minimizing the influence of voltage variation, power factor, burden, temperature, frequency, and harmonics. Instrument transformers used must be suitable for use in revenue metering systems and must comply with the minimum acceptable accuracy standards listed in the *Guide for Uniform Practices in*

Revenue Quality Metering (available at <https://www.nyiso.com/manuals-tech-bulletins-user-guides> (expand "Manuals," click on "Additional Materials"))).

TOs may require Market Participants to install an approved RTU or analog telemetry equipment for the accurate and economical transmission of the Market Participant's data to the TO.

3.2.1. Meter Configuration for Behind-the-Meter Net Generation Resources

Behind-the-Meter Net Generation Resources will be required to use one of three possible metering configurations. All meters and metering instruments that are used to facilitate participation as a Behind-the-Meter Net Generation Resource must have real-time telemetry and be accepted by the MA, and must meet the applicable requirements below.

- Option 1 - "net" facility revenue meter(s) at the high side of the GSU, meter(s) measuring the gross load compensated for the high side of GSU and meter(s) measuring the gross generation compensated for the high side of GSU
- Option 2 - "net" facility revenue meter(s) at the high side of the GSU and meter(s) measuring the gross load compensated for the high side of GSU
- Option 3 - "net" facility revenue meter(s) at the high side of the GSU and meter(s) measuring the gross generation compensated for the high side of GSU

Figure 1: Behind-the-Meter Net Generation Resource Metering Configurations (for illustration purposes only)

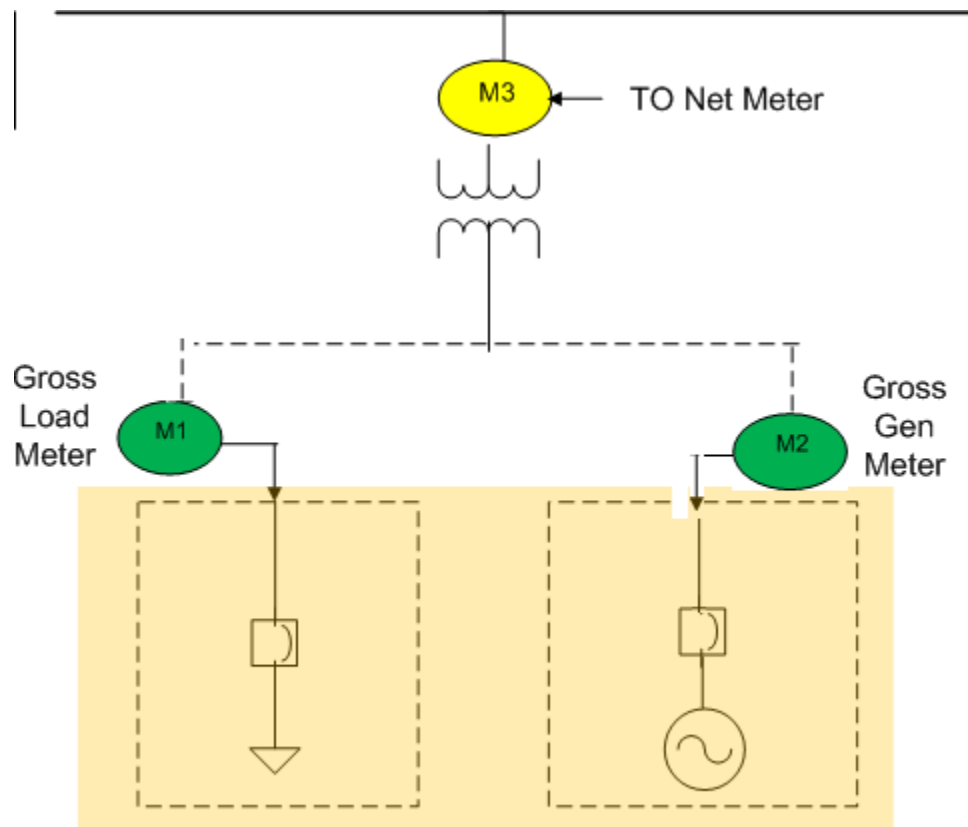

Note: Option 1: M3, M2 compensated for high side of GSU, M1 compensated for high side of GSU

Note: Option 2: M3, M1 compensated for high side of GSU (NYISO estimates M2 compensated for high side of GSU)

Note: Option 3: M3, M2 compensated for high side of GSU (NYISO estimates M 1 compensated for high side of GSU)

3.2.2. Meter Configuration for Energy Storage Resources

Energy Storage Resources (ESRs) shall be directly metered, regardless of the location on the system (including those that are co-located with a retail Load) in order to measure ESR Energy injections and withdrawals separately from other Energy injections or withdrawals taking place at the facility. If the ESR is co-located with another load facility, the Load data the MA submits to the NYISO shall exclude the Energy injections and withdrawals of the ESR. All meters and metering instruments that are used to facilitate participation as an ESR must have real-time telemetry and be accepted by the MA, and must meet the

applicable requirements below.

Figure 2: ESR Collocated with a Load Metering Configuration (for illustration purposes only)

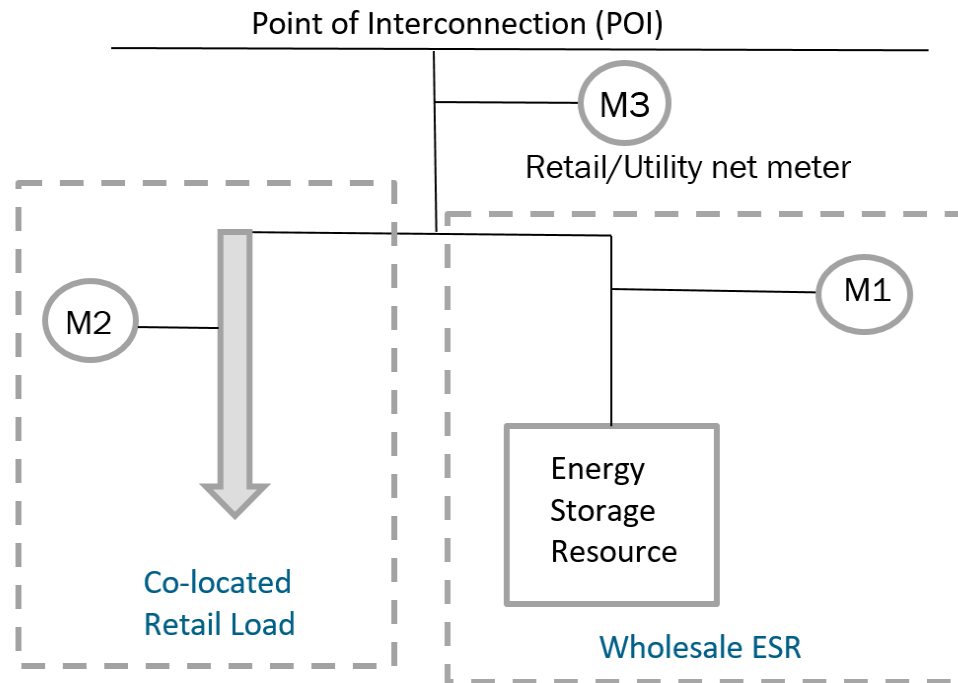

M1 meter - Telemetry and settlement data from the ESR through the Transmission Owner's SCADA system.
 M2 meter – Collocated Load is accounted for as part of the LSE's retail load by the meter authority.
 This configuration requires the meter authority to adjust LSE's retail load calculation to exclude the energy that the ESR exchanges with the grid.
Note: Additional meters may be required to differentiate Energy withdrawn for later injection to the grid from Energy used for Station Power.

3.2.3. Meter Configuration for Co-located Storage Resources (CSR)

CSRs shall have a dual channel Revenue Grade Meter (AC) at the Point of Injection (POI). This meter must be capable of separately recording Energy injections and Energy withdrawals. The Revenue Grade Meter data at the POI will be used for settlement purposes. CSRs shall provide 6-second telemetry data at the POI. The telemetry data shall reflect the total Energy injections and Energy withdrawals of the CSR. Each unit shall provide 6-second telemetry for output and control signals. The telemetry should be compensated to the equivalent AC output at the POI. The 6-second tele-metered data will be used for real-time operations. Energy Level (state of charge) 6-second telemetry data will be required for the Energy Storage Resource (ESR) unit. Wind or solar forecast information will be required for the Intermittent

Power Resource (IPR). Forecast information for the IPR unit shall include all the meteorological data as well as outage information.

Figure 3: Co-located Storage Resource Metering Configuration (for illustration purposes only)

Co-located Storage Resource (CSR) Metering

Meter Designation	Meter Requirements	Data flows
RM1	Revenue grade; dual – channel meter; reported by a Meter Authority	Hourly data
IM -1	Instantaneous meter	6 second aggregated output telemetry from CSR
TM - 1	SCADA data	ESR State of Charge (SOC) telemetry
TM -2	SCADA data	6-second aggregated output telemetry from ESR (telemetry should be compensated to the equivalent AC output at the POI)
TM -3	SCADA data	6 second aggregated output telemetry from Solar PV (telemetry should be compensated to the AC equivalent output at the POI)

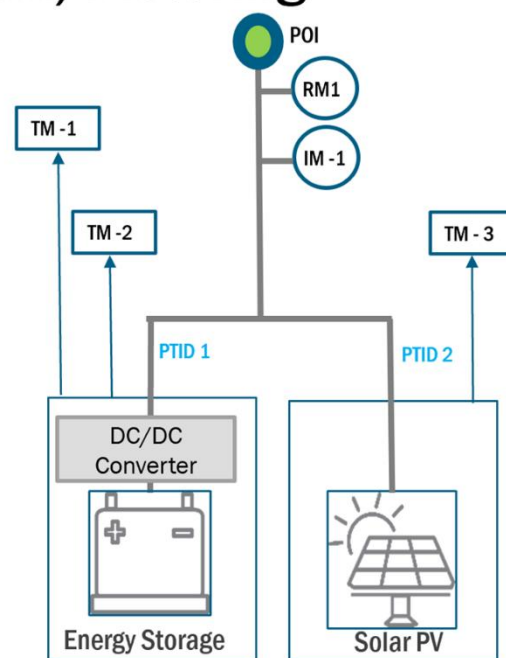

3.2.4. Zonal and Sub-zonal Tie Line Boundaries

Zonal and Sub-Zonal Tie line meters will be installed at the defined point between regions, whenever practicable. If a Zonal or Sub-Zonal Tie line meter must be installed at an alternate location, it will be compensated to the defined boundary point between regions.

3.3. Calibration and Maintenance

This section provides standards for calibration and maintenance. It describes the documentation requirements, and an outlined process for routine and Market Participant initiated testing.

3.3.1. Calibration and Maintenance Standards

Calibration of revenue metering systems used to provide MWhr data to the NYISO will adhere to the *Guide for Uniform Practices in Revenue Quality Metering* (available at <https://www.nyiso.com/manuals-tech-bulletins-user-guides> (expand "Manuals," click on "Additional Materials")) to ensure the accuracy of

NYISO settlements. All revenue metering data supplied for final balancing and billing purposes must be based on energy measurements made with instruments that are traceable to the National Institute of Standards and Technology (NIST) and approved for billing purposes within NYS. If existing metering systems are not compliant with the *Guide for Uniform Practices in Revenue Quality Metering*, the metering systems should be calibrated to meet the following standards:

1. **Calibration Interval** — Calibration of equipment will be performed in accordance with the manufacturer's recommended intervals and procedures. Where a manufacturer does not provide calibration interval recommendations, the interval should be based on equipment stability as demonstrated by historic data. In no case should the calibration interval exceed two years.
2. **Test Range Increments** — Checks will be made in 20 percent increments for Transducers from zero to 100 percent, inclusive of rated input, or as specified by the manufacturer if more stringent. Test range increments for revenue grade metering devices will reflect those specified in ANSI C12.1 - American National Standard Code for Electricity Metering.
3. **Maximum Errors** — Transducer error must not exceed 0.25 percent of full scale or manufacturer's specifications, whichever is less. Errors exceeding the above, after calibration, indicate the transducer should be replaced or returned for repair and recalibration. If replacement is required, a new state-of-the-art transducer will be used.

If Digital Telemetry error is found to be more than 0.1 percent \pm the least significant bit outside the manufacturer's specifications, whichever is less, the cause will be determined, and the error reduced to specifications.

If analog telemetry is found to be outside accuracy specifications, the cause will be determined and the error corrected to specifications. The error should not exceed \pm 0.1 percent of the reading, or as current technology permits.

4. **Overall Tests** — Each data point will be calibrated from source (transducer) to NYISO in 20 percent increments from zero to 100 percent of rated input. Using a calibrated power supply input to the transformer, the final NYISO reading will not exceed + or - 0.25% of reading or full scale.

Where the same data is telemetered in both analog and digital forms, the calibration will be performed at the same time and the data received at the NYISO must be within the \pm 1percent range of each other. The comparison will be performed using actual live data.
5. **Test Equipment** — All test equipment will be traceable to the NIST. Test equipment will conform to the requirements of the *Guide for Uniform Practices in Revenue Quality Metering*. Calibration intervals will be in accordance with manufacturer recommendations.
6. **Maintenance** — If periodic maintenance or failures indicate poor reliability, the equipment must be replaced. If errors exist, the defective component will be isolated and remedial action taken.

3.3.2. Calibration Documentation and Auditing

The MAs shall maintain records of the testing and calibration of all metering equipment for which they are responsible. The records shall include, at a minimum, the dates of testing and calibration, and if the meter passed the calibration test. These records shall be retained for two years and shall be available to NYISO upon request.

The NYISO has the right to audit the MA calibration records that are required to be maintained by this manual. The MA will inform the NYISO of corrective actions if the NYISO has determined, through its audit, that metering equipment is not within calibration requirements. *See* Section 10 of the NYISO Market Services Tariff (available from the NYISO Web site at <https://www.nyiso.com/regulatory-viewer>).

3.3.3. Metering System Inspection and Testing

If the accuracy of data provided by a particular metering system is in doubt, the NYISO or affected party can request to witness a calibration test and inspection of the meter system in question. This request must be made in writing through the NYISO, and should include the nature and magnitude of the suspected inaccuracies. The NYISO will review all requests for witness testing and inspections, and facilitate dispute resolution in accordance with [Section 5.3](#) of this manual.

If the responsible MA fails to address the suspected inaccuracies satisfactorily through dispute resolution, the NYISO will require the MA to propose a calibration test and inspection plan to eliminate the various possible sources of error (e.g., meter, CTs, PTs, wiring) in the most logical manner. This plan should include estimated costs associated with the proposed tests. The NYISO will consult the affected parties to determine the acceptability of the proposed plan and estimated costs prior to scheduling the testing with the MA.

If the NYISO determines from the tests and inspections that the suspected meter is within calibration tolerances and no discrepancies exist which could create the suspected inaccuracies, the party requesting the testing must reimburse the MA for the associated costs.

The NYISO may also witness test and inspect revenue meters during regularly scheduled calibration or maintenance performed by MAs. These visits should be scheduled so that it prevents any incremental costs to the MA than those incurred as part of their periodic calibration program.

4. NYISO Revenue Data Requirements

This section specifies MWhr revenue meter data requirements, and analog and digital telemetry data requirements to support settlements.

4.1. Revenue Metering Data

All revenue metering data supplied for final balancing and billing purposes must be based on energy measurements made with instruments that can be traced to the NIST, meet the specifications of the *Guide for Uniform Practices in Revenue Quality Metering* (available at <https://www.nyiso.com/manuals-tech-bulletins-user-guides> (expand "Manuals," click on "Additional Manuals")), and are approved for billing purposes within New York State. The use of Supervisory Control and Data Acquisition (SCADA) data for settlement will only occur if revenue grade data not is available. In the event that an affected party disagrees with data submitted by a MA, the MA should be informed and an attempt should be made to resolve the problem in accordance with [Section 5.1.2](#) of this manual.

MWhr Revenue Metering Systems will be required:

1. On inter- NYCA ties, intra-NYCA ties that make up the metering point for zonal and sub-zonal ties, and
2. On all generators above 1-MW. Non-dispatchable generation may be provided in the form of plant total or group total dependent on how the owner intends to bid the generation. MWhrs will be measured on the high side of the GSU.

4.2. Digital and Analog Telemetry

Digital and analog telemetry may be used as a back-up source for revenue meter data on a temporary basis, not to exceed ninety (90) days. Requirements for these data sources may be found in the *NYISO Control Center Requirements Manual* (available at <https://www.nyiso.com/manuals-tech-bulletins-user-guides> (expand "Manuals," click on "Administrative"))).

4.3. Meter Authority Requirements

The NYISO will accept revenue meter data only from an approved MA—*i.e.*, a Member System or a Meter Services Entity. An entity may apply to be a Meter Services Entity by contacting the NYISO Member Relations Department. Although a MSE may provide meter data to the NYISO as a MA, all meter owners must attest annually to the NYISO that their meters are serviced by an MSE that is qualified for the applicable voltage and meter types.

4.4. Data Processing

The MA will provide instantaneous and hourly metered data to the NYISO and the TO. The hourly-metered data will meet the requirements of this manual and the *Guide for Uniform Practices in Revenue Quality Metering* (available at <https://www.nyiso.com/manuals-tech-bulletins-user-guides> (expand "Manuals," click on "Additional Manuals")). The instantaneous meter data will meet the requirements of the *NYISO Control Center Requirements Manual* (available at <https://www.nyiso.com/manuals-tech-bulletins-user-guides> (expand "Manuals," click on "Administrative"))).

Any LSE that is not metered on an hourly or instantaneous basis, will have its load determined by the TO in whose Load Sub-Zone it is located.

All MAs that report data for Sub-Zonal Ties and Generators used in the calculation of the NYISO market settlements will also include hourly profile data. Revenue metering data should be submitted to the NYISO by the next business day.

4.4.1. Generator and Tie-line Meter Data Tasks

The MA is responsible for reporting the highest quality data available to them, to allow the NYISO to accurately calculate daily Advisory Billing for the market. The MA will review reported data and make necessary corrections, then upload the data to the NYISO using the SDX system. The MA will respond to Market Participants affected by their metering that challenge the accuracy of the hourly interval metering and make every effort to ensure the best available data is reported to the NYISO. This process occurs daily for the current month from the 1st of the month through current day -2 to ensure accurate settlements for the initial run. In addition, meter data review takes place for all historical months the NYISO is preparing to invoice (e.g., the 4-month settlement adjustment or the Final Bill Close out invoice). For an initial invoice, the accuracy of generator and tie-line data is important not only for Power Supplier billing, but also for LSE billing since customer loads are calculated by the NYISO based on load forecast and Sub-Zonal loads.

The MA must review the NYISO SDX data each day and investigate discrepancies between MA data and the NYISO's PTS data, using alternate data sources if available. If a discrepancy exists between PTS and reported MA data in SDX, and the MA has confirmed the accuracy of the hourly data then the MA must notify the NYISO that it believes there may be a problem with the PTS data. This enables the NYISO to look into possible problems with PTS data that is being used in the billing calculations.

4.4.2. Tasks Concerning the Meter Authority TOL Process

For rebilling or settlement adjustments calculated after an initial monthly invoice, the MA is responsible for reporting customer loads calculated from the Sub-Zonal loads. Realizing different processes

exist from one MA to another it is still expected that the customer data the MA is posting using SDX, summed for the loads within a Sub-Zone, is equal to the Sub-Zonal load scaled for NYISO calculated losses.

4.4.3. NYISO Meter Data Process

The NYISO will provide a schedule named “Hourly Tie-line, Generator, and LSE Bus Meter Data Review, Revision, & Lock-down Schedule” identifying due dates and status related to NYISO invoices for the generator, tie-line, and customer load data.

The NYISO is responsible for maintaining all hardware, software, and data in the SDX system.

The NYISO will calculate hourly losses per sub-zone and provide the Market Participants the data in SDX.

The NYISO will maintain all data uploaded from the MA in the SDX system, along with a history of data changes from the MA. The NYISO will also post the hourly integrated real time data PTS for comparison to the reported MA data for each hour.

The NYISO uses both the PTS and hourly reported MA data to compute real-time interval level and hourly billing. The NYISO will review the posted PTS data daily for possible anomalies that may have occurred during the measurement process. The NYISO will email an error report to the MA’s meter data contact person if there are a large number of discrepancies between MA and PTS hourly interval data.

The generator, tie-line, and load data will be “locked-down” by the NYISO, and MAs will be unable to make changes as per the “Hourly Tie-line, Generator, and LSE Bus Meter Data Review, Revision, & Lock-down Schedule” schedule provided by the NYISO to ensure to the Market Participants that the metering and billing data is consistent.

For months that the NYISO is performing a settlement adjustment prior to rerunning the billing system, checks will be performed on the MA reported customer loads to ensure that they are within tolerance of the SDX calculated Sub-Zonal load. The NYISO will notify the responsible MA of any discrepancies.

4.5. Metering Improvement Priorities

The various data parameters transmitted to NYISO will be prioritized based on electric system costs, flow limits, operating limits, and security considerations. These priorities will determine the basis on which metering replacements and improvements are to be completed. The priority classes are as follows:

1. Sub-Zonal Tie Transmission Line Megawatts/MWHrs Inter-NYCA Transmission Lines Megawatts and Megavars
2. Generator Megawatts/ MWHrs and Megavars
3. Transmission Lines Megawatts and Megavars

The priorities for metering improvements for use by the SCADA system should also be taken into account, and can be found in the NYISO *Control Center Requirements Manual* (available at <https://www.nyiso.com/manuals-tech-bulletins-user-guides> (expand "Manuals," click "Administrative"))).

5. Data Analysis and Data Problem Resolution

This section provides procedures for the analysis, reporting, and resolution of data problems for revenue metering data used to settle the NYISO markets.

5.1. Metering and Data Accuracy Analysis

This section outlines the process for analyzing, reporting, and resolving data problems.

5.1.1. Responsibilities

The NYISO is responsible for analyzing all metering and data anomalies as reported to it by the NYISO or Market Participants.

The Billing, Accounting & Credit Policy Working Group (BACWG) is responsible for maintaining a liaison between the NYISO and Market Participants for problem analysis and resolution. Additionally, all metering problems that cannot be satisfactorily resolved by the NYISO should be reported to the BACWG for appropriate action.

5.1.2. Procedure

If the NYISO or a Market Participant suspects a problem exists with a particular meter or its data, they should contact the responsible MA and provide details on the suspected inaccuracies. The responsible MA should immediately initiate an investigation into the suspected problem.

The MA will provide the party who informed them of the potential problem a status of the investigation within five working days, and also provide them with a report of the probable cause of the data problem, proposed resolution and expected time to implement, as soon as practicable. If the proposed resolution and time for implementation are not acceptable to the requesting party, the Dispute Resolution process may be used (see [Section 5.3](#)).

5.1.3. Reporting

Semi-annually, the NYISO will provide the BACWG with a report on recent or continuing revenue meter problems. The report will include:

1. A summary of problems and resolutions during the report period, and
2. Details of unresolved problems.

5.2. Loss of Metering Data

The responsible MA will use the best available information to fill in data lost – either due to a meter problem or failures in the communication process to the NYISO. While a back-up meter should be identified as a secondary source of data for each revenue meter, the MA may need to utilize logs, schedules or combinations of other meter readings to fill in values for data lost. If the data transmission to the NYISO is delayed, the MA will make a reasonable effort to transmit the data using other electronic means acceptable to the NYISO. All failed telemetry, metering, and communications equipment will be rendered operable in the shortest practical time and calibration compliance must be reported to the TO and the NYISO. In all cases, NYS PSC rules will be enforced.

5.3. Procedures for Dispute Resolution of Data Issues

If a Market Participant is unable to resolve a data problem through their MA, they should inform the NYISO of the dispute. The NYISO will consult with the reporting Market Participant and the responsible MA to determine what data is available. The NYISO will determine the best data to be used in the settlement. A response from the NYISO to the complainant should be available to all affected Market Participants within 30 days of receipt. The NYISO will maintain documentation of all revenue data disputes.

If a Market Participant believes that a revenue meter affecting their settlement is not functioning properly, they may follow the inspection and testing process found in [Section 3.3.3](#). In all cases, relevant NYS PSC rules will be enforced.

5.4. Further Actions

The NYISO may initiate a formal investigation by its Market Monitoring Unit if, either during or after completing the processes described in sections 5.1 through 5.4 of this manual, the NYISO suspects a Market Participant of manipulating metering or metering data or of continued negligence in performing required duties or submitting required data. For further guidance, see the NYISO *Market Monitoring Plan* for further guidance (available at <https://www.nyiso.com/market-monitoring>).