



Manual 14

Accounting and Billing Manual

Issued: July 2026

Version: 8.0

Effective Date: 07/01/2026

Committee Acceptance: 06/10/2026 BIC

Recertified Date: 04/16/2024

Prepared By: NYISO Customer Settlements

New York Independent System Operator
10 Krey Boulevard
Rensselaer, NY 12144
(518) 356-6060
www.nyiso.com

Disclaimer: The information contained within this manual, along with other NYISO manuals, is intended to be used for information purposes only, and is subject to change. The NYISO is not responsible for the user's reliance on these publications, or for any erroneous or misleading material.

Dedication to Randy Bowers

Randy A. Bowers (1961-2010), NYISO Principal and former Manager of Customer Settlements, was the original author of this Accounting and Billing Manual. His passion for and extensive knowledge of the electric industry, along with his insights and hard work, are evidenced in this manual. It is only fitting that we dedicate this Accounting and Billing Manual to Randy A. Bowers for his vision to the future, dedication to the electric industry, and commitment to excellence.

Table of Contents

DEDICATION TO RANDY BOWERS	III
TABLE OF CONTENTS	IV
REVISION HISTORY	XIX
RELATION OF THIS MANUAL TO NYISO’S TARIFFS AND AGREEMENTS	XXIII
1. SETTLEMENT AND INVOICING PROCESS	1
1.1.Settlement Processing.....	1
1.1.1. <i>Processing Prior to Initial Invoice Issuance</i>	1
1.2.Weekly Invoice Processing	2
1.2.1. <i>Settlement Period</i>	2
1.2.2. <i>Invoice Format</i>	3
1.2.3. <i>Invoicing Schedule</i>	3
1.2.4. <i>Clearing (Payment)</i>	4
1.3.Monthly Invoice Processing.....	4
1.3.1. <i>Invoice Format</i>	4
1.3.2. <i>Invoice Adjustments</i>	4
1.3.3. <i>Invoicing Schedule</i>	5
1.3.4. <i>Consolidated Invoicing</i>	5
1.3.5. <i>Interest Payments and Charges</i>	6
1.3.6. <i>Clearing (Payment)</i>	7
1.4.Resettlement (i.e., True-ups)	7
1.4.1. <i>Meter Data Revision Sunset Provisions</i>	7
1.5.Close-out Invoice and Resettlement Sunset Provision	8
1.6.Settlement and Invoice Support.....	9
1.6.1. <i>Bidding and Scheduling System</i>	9
1.6.2. <i>Settlement Data Applications</i>	9
1.6.3. <i>Decision Support System (DSS)</i>	11
1.6.4. <i>OASIS</i>	12
2. MARKET PARTICIPANT RESPONSIBILITIES AND CONTROLS	13
3. SETTLEMENT AND INVOICE INQUIRIES, CHALLENGES, AND DISPUTE PROCESSES.....	14
3.1.Submission of Inquiries, Challenges, and Disputes.....	14
3.2.Inquiries, Settlement Challenges, and Updates Prior to Initial Invoicing.....	14
3.2.1. <i>Generation, Transmission Line, and Sub-Zone Load Meter Data Management</i>	15
3.2.2. <i>Allocation of Sub-Zonal Loads to LSEs and LSE Meter Data Management Prior to Initial Invoicing</i>	17
3.3.Settlement and Invoice Challenges	18

3.3.1.	<i>Submission of Settlement and Invoice Challenges</i>	19
3.3.2.	<i>Transmission Interconnection, Generator, and Sub-Zone Load Metering Data Management and Challenges after Invoicing</i>	20
3.3.3.	<i>LSE Metering Data Management and Challenges after Invoicing</i>	22
3.4.	Settlement and Invoice Disputes	24
3.4.1.	<i>Expedited Dispute Resolution Procedures for Unresolved Settlement Challenges</i>	24
3.5.	Customer Default	26
3.5.1.	<i>Default Event</i>	26
3.5.2.	<i>Cure of Default</i>	27
3.5.3.	<i>The NYISO’s Right to Suspend and/or Terminate Service</i>	28
4.	ENERGY SUPPLIER SETTLEMENTS	29
4.1.	Energy Supplier Settlement – Generators.....	29
4.1.1.	<i>DAM Energy Supplier Settlement – Generators</i>	29
4.1.2.	<i>DAM Bid Production Cost Guarantee (BPCG) - Generators</i>	29
4.1.3.	<i>Balancing Market Energy Supplier Settlement – Generators</i>	31
4.1.4.	<i>Real-Time Bid Production Cost Guarantee for Generators in RTD Intervals Other than Supplemental Event Intervals</i>	34
4.1.5.	<i>BPCG for Generators for Supplemental Event Intervals</i>	37
4.1.6.	<i>BPCG for Long Start-Up Time Generators Whose Starts Are Aborted by the NYISO Prior to their Dispatch</i>	38
4.1.7.	<i>Day-Ahead Margin Assurance Payments (DAMAP)</i>	38
4.1.8.	<i>Cost Recovery for Units Responding to Local Reliability Rule G.2 or G.3</i>	47
4.1.9.	<i>Performance Tracking</i>	49
4.1.10.	<i>Energy Storage Resource Charging at Retail– Generator Rebate</i>	49
4.1.11.	<i>Energy Storage Resource Transmission Service Charges</i>	49
4.2.	Energy Supplier Settlement – Demand Reduction Providers	50
4.2.1.	<i>DAM Energy Supplier Settlement – Demand Reduction Providers</i>	50
4.2.2.	<i>BPCG for Demand Reduction in the Day-Ahead Market</i>	50
4.2.3.	<i>Balancing Market Energy Supplier Settlement – Demand Reduction Providers</i>	51
4.3.	Energy Supplier Settlement – LBMP Energy Imports.....	52
4.3.1.	<i>DAM Energy Supplier Settlement – LBMP Energy Imports</i>	52
4.3.2.	<i>Day-Ahead BPCG for Imports</i>	52
4.3.3.	<i>Balancing Market Supplier Settlement – LBMP Energy Imports</i>	52
4.3.4.	<i>Real-Time BPCG for Imports</i>	53
4.3.5.	<i>Import Curtailment Guarantee Payments</i>	53
4.4.	Energy Supplier Settlement – Virtual Energy Suppliers.....	54
4.4.1.	<i>DAM Energy Supplier Settlement – Virtual Suppliers</i>	54
4.4.2.	<i>Balancing Market Energy Supplier Settlement – Virtual Suppliers</i>	54
4.5.	Energy Settlement – Emergency Demand Response Program Participants.....	54
4.5.1.	<i>Concurrent Enrollment in More Than One Demand Response Program</i>	55
4.5.2.	<i>BPCG for Special Case Resources</i>	55

5. ANCILLARY SERVICES SUPPLIER SETTLEMENTS.....	56
5.1.Voltage Support Service.....	56
5.1.1. <i>Method for Determining the Payments for Voltage Support Service</i>	56
5.1.2. <i>Payments for Voltage Support Service Provided by Suppliers with Installed Capacity Contracts</i> ...	56
5.1.3. <i>Payments for Voltage Support Service Provided by Suppliers without Installed Capacity Contracts</i>	56
5.1.4. <i>Payments to the Cross-Sound Scheduled Line and CHPE MTF for Voltage Support Services Provided</i>	57
5.1.5. <i>Payments for Lost Opportunity Cost</i>	57
5.1.6. <i>Failure to Perform by Suppliers</i>	58
5.2.Regulation and Frequency Response Service.....	59
5.2.1. <i>Regulation Service Settlements – Day-Ahead Market</i>	59
5.2.2. <i>Regulation Service Settlements – Real-Time Markets</i>	60
5.2.3. <i>Energy Settlement Rules for Generators Providing Regulation Service</i>	61
5.2.4. <i>Charges to Suppliers Not Providing Regulation Service</i>	62
5.3.Operating Reserve Service	64
5.3.1. <i>DAM Settlement of Operating Reserve</i>	64
5.3.2. <i>Other Day-Ahead Payments</i>	64
5.3.3. <i>Balancing Settlement of Operating Reserve</i>	64
5.3.4. <i>Quick Start Reserves</i>	66
5.4.Black Start Capability Service	66
5.4.1. <i>Settlements for Generators under the Black Start and System Restoration Services Plans Developed by the NYISO and by Individual Transmission Owners Other Than Consolidated Edison</i>	66
5.4.2. <i>Payments to Generators Providing Black Start and System Restoration Services under the Consolidated Edison Transmission District Plan</i>	67
6. ENERGY PURCHASE SETTLEMENTS.....	72
6.1.Energy Settlement – Load Serving Entities (LSEs).....	72
6.1.1. <i>DAM Energy Settlement – LSEs</i>	72
6.1.2. <i>Balancing Market Energy Settlement – LSEs</i>	72
6.1.3. <i>Energy Storage Resource Retail Settlement – LSEs</i>	73
6.2.Energy Settlement – LBMP Energy Exports.....	73
6.2.1. <i>DAM Energy Settlement – LBMP Energy Exports</i>	73
6.2.2. <i>Balancing Market Settlement – LBMP Energy Exports</i>	73
6.3.Energy Settlement – Virtual Loads.....	74
6.3.1. <i>DAM Energy Settlement – Virtual Loads</i>	74
6.3.2. <i>Balancing Market Energy Settlement – Virtual Loads</i>	75
6.4.Energy Settlement – Station Power	75
6.4.1. <i>Self-Supply Station Power</i>	75
6.4.2. <i>Third-Party Station Power</i>	76
6.4.3. <i>Remote Self-Supply Station Power</i>	76

7. TRANSMISSION USAGE CHARGE (TUC) AND TRADING HUB ENERGY SETTLEMENTS.....	78
7.1.TUC Settlements – Internal Transactions.....	78
7.1.1. DAM TUC Settlements – Internal Transactions	78
7.1.2. Balancing Market TUC Settlements – Internal Transactions	79
7.2.TUC Settlements – Import Bilateral Transactions.....	80
7.2.1. DAM TUC Settlements – Import Bilateral Transactions.....	80
7.2.2. Balancing Market TUC Settlements – Import Bilateral Transactions	81
7.3.TUC Settlements – Export Bilateral Transactions	83
7.3.1. DAM TUC Settlements – Export Bilateral Transactions	83
7.3.2. Balancing Market TUC Settlements – Export Bilateral Transactions.....	84
7.4.TUC Settlements – Wheel Through Transactions.....	86
7.4.1. DAM TUC Settlements – Wheel Through Transactions	86
7.4.2. Balancing Market TUC Settlements – Wheel Through Transactions.....	86
7.5.Adjustment to Congestion Relief for Transactions Claiming Grandfathered Transmission Rights	
.....	88
7.6.NYPA Transmission Adjustment Charge (NTAC).....	88
7.6.1. Exports and Wheels Through.....	88
7.6.2. Imports, Internal Bilaterals, and Loads within the NYCA.....	89
7.6.3. Energy Storage Resource.....	89
7.7.Trading Hub Energy Settlements.....	90
7.7.1. Day-Ahead Market Energy Settlements at Trading Hub Point of Injection Buses	90
7.7.2. Real-Time Market Energy Settlements at Trading Hub Point of Injection Buses.....	90
7.7.3. Day-Ahead Market Energy Settlements at Trading Hub Point of Withdrawal Buses	90
7.7.4. Real-Time Market Energy Settlements at Trading Hub Point of Withdrawal Buses.....	90
7.8.1. External Transaction TSC MWh Reporting	91
8. ANCILLARY SERVICES AND OTHER CHARGES	92
8.1.NYISO Annual Budget Charge and Other Non-Budget Rate Schedule 1 Charges and Payments	
(OATT)	92
8.1.1. NYISO Annual Budget Charge.....	92
8.1.2. NYISO Annual Budgeted Costs.....	93
8.1.3. NERC and NPCC Charges	94
8.1.4. Bad Debt Loss Charge.....	94
8.1.5. Working Capital Fund Charge.....	94
8.1.6. Non-NYISO Facilities Payment Charge.....	95
8.1.7. Payments Made to Generators Pursuant to Incremental Cost Recovery for Units Responding to	
Local Reliability Rules G.2 and G.3	95
8.1.8. Residuals Costs Payment\Charge.....	95
8.1.9. Recovery of Special Case Resources and Curtailment Service Providers Costs	96
8.1.10. Day-Ahead Margin Assurance Payments	97

8.1.11.	<i>Import Curtailment Guarantee Payments</i>	97
8.1.12.	<i>Bid Production Cost Guarantee Payments</i>	97
8.1.13.	<i>Dispute Resolution Payment\Charge</i>	101
8.1.14.	<i>Credit for Financial Penalties</i>	101
8.1.15.	<i>Calculation of FERC Fee Costs</i>	101
8.2.	Scheduling, System Control, and Dispatch Service (Services Tariff)	102
8.2.1.	<i>Annual Budget and Other Non-Budget Charges and Payments</i>	102
8.3.	Voltage Support Service	102
8.4.	Regulation and Frequency Response Service	103
8.5.	Energy Imbalance Service	104
8.6.	Operating Reserves Service	104
8.6.1.	<i>Quick-Start Reserves Service</i>	105
8.7.	Black Start Service	106
8.8.	Penalty Cost Recovery	106
8.8.1.	<i>Allocation of Costs Associated with NERC Penalty Assessments When NYISO is the Registered Entity</i>	107
8.8.2.	<i>Allocation of Costs Associated with NERC Penalty Assessments When Customer is the Registered Entity</i>	108
8.8.3.	<i>Allocation of Costs Associated with Other Reliability Penalty Assessments</i>	109
8.8.4.	<i>Allocation of Costs Associated with Penalty Assessments</i>	110
8.9.	Reliability Facilities Charge Recovery	111
8.9.1.	<i>Allocation of Costs Associated with Reliability Facilities Charge</i>	111
8.9.2.	<i>Recovery of Transmission Owner’s Costs Related to Regulated Reliability Transmission Solutions</i>	112
8.9.3.	<i>Recovery of Costs by an Unregulated Transmitting Utility</i>	115
8.9.4.	<i>Recovery of Costs Incurred by an Other Developer Related to an Alternative Regulated Solution</i>	116
8.10.	Recovery of the Highway Facilities Charge	117
8.10.1.	<i>Recovery of Transmission Owner’s Costs Related to Highway System Delivery Upgrades</i>	118
8.10.2.	<i>Highway Facilities Charge Revenue Requirement Recovery</i>	118
8.10.3.	<i>Headroom Accounting</i>	120
8.11.	Charges for Intermittent Power Resource Forecasting Service	120
8.12.	Reliability Must Run (RMR) Charge Recovery	121
8.13.	Recovery for Costs for Demand Reductions Associated with DER Aggregations	121
9.	TRANSMISSION CONGESTION CONTRACT SETTLEMENTS	122
10.	TRANSMISSION OWNER SETTLEMENTS	123
10.1.	Net DAM Congestion Rent Balancing	123

10.1.1.	<i>Calculation and Allocation of Net Congestion Rents</i>	123
10.2.	NYPA Transmission Adjustment Charge (NTAC)	126
10.3.	Transmission Service Charge MWh Reporting to Transmission Providers	127
10.3.1.	<i>External Transaction TSC MWh Reporting</i>	127
10.3.2.	<i>Energy Storage Resource Storage Withdrawals TSC MWh Reporting</i>	127
APPENDIX A.	INFORMATION REGARDING TSCS	128
APPENDIX B.	SUPPLIER ENERGY SETTLEMENT FORMULAE	129
B.1.	Day-Ahead Energy Settlements for Generators and Virtual Supply	129
B.2.	Real-Time, Balancing Energy Settlements for Generators other than Limited Energy Storage Resources.....	129
B.3.	Real-Time, Balancing Energy Settlements for Limited Energy Storage Resources	132
B.4.	Day-Ahead Energy Settlements for LBMP Market Energy Imports	132
B.5.	Real-Time, Balancing Energy Settlements for LBMP Market Energy Imports	132
B.6.	Financial Impact Charge (FIC) for LBMP Market Energy Imports Failing the NYISO Check-out Process	133
B.7.	Incentive payment for Day-Ahead Demand Reduction Providers	134
B.8.	Demand Reduction Imbalance Charge to Demand Reduction Providers and LSEs.....	134
B.9.	Real-Time, Balancing Energy Settlements for Virtual Supply	136
APPENDIX C.	OUT OF MERIT OPERATION IMPACTING SETTLEMENTS	137
APPENDIX D.	INTENTIONALLY LEFT BLANK	140
APPENDIX E.	BID PRODUCTION COST GUARANTEE FORMULAE	141
E.1.	Day-Ahead Bid Production Guarantee (DAM BPCG).....	141
E.2.	Total Energy Required to be Provided in Order to Avoid Proration of a Generator's Start-Up Costs	142
E.3.	Calculation of Prorated Start-Up Cost	143
E.4.	Formula for Determining Real-Time BPCG for Generators and Aggregations in RTD Intervals Other Than Supplemental Event Intervals	144
E.5.	Formula for Determining Real-Time BPCG for Generators and Aggregations in Supplemental Event Intervals	148
E.6.	Day-Ahead BPCG for Imports.....	150

E.7.	Day-Ahead BPCG for Demand Reduction	150
E.8.	Day-Ahead BPCG for Demand Side Resources Providing Synchronized Operating Reserves and/or Regulation Service	151
E.9.	Real-Time BPCG for Demand Side Resources Providing Synchronized Operating Reserves and/or Regulation Service	151
E.10.	Import Curtailment Guarantee Payment for a Supplier Whose Import Was Curtailed by the NYISO.....	152
APPENDIX F.	ECONOMIC OPERATING POINT	154
APPENDIX G.	REAL-TIME PERFORMANCE TRACKING.....	158
G.1.	Average Injection over an RTD Interval	158
G.2.	Average Withdrawal over an RTD Interval	158
G.3.	Average Demand Reduction over an RTD Interval	158
G.4.	Average Tie Flow over an RTD Interval	159
G.5.	Average Ramped RTD Base-point per RTD Interval.....	159
G.6.	Unit Average Desired Generation per RTD Interval.....	159
G.6.1.	For Suppliers providing Regulation Service	159
G.6.2.	For Suppliers not providing Regulation Service:.....	159
G.7.	Negative Control Error for Suppliers providing Regulation Service	160
G.8.	Positive Control Error for Suppliers that are providing Regulation Service.....	160
G.9.	Regulation Performance Index.....	160
G.10.	Reserve Performance Index.....	161
G.11.	Total Regulation Movement.....	161
APPENDIX H.	DAM MARGIN ASSURANCE PAYMENTS (DAMAP).....	162
H.1.	Hourly DAMAP for Generators	162
H.2.	RTD Interval Energy Component of DAMAP When Eligible Generators' Real-Time Energy Schedules are Less Than Their DAM Energy Schedules	162
H.3.	RTD Interval Energy Component of DAMAP When Eligible Generators' Real-Time Energy Schedules are Greater Than or Equal to Their DAM Energy Schedules	164

H.4.RTD Interval Regulation Service Component of DAMAP When Eligible Generators’ Real-Time Regulation Schedules are Different than their DAM Regulation Schedules.....	165
H.4.1.Real-Time Regulation Service schedule less than Day-Ahead Regulation Service schedule:	165
H.4.2.Real-Time Regulation Service schedule greater than or equal to the Day-Ahead Regulation Service schedule:.....	166
H.5.RTD Interval Operating Reserves Component of DAMAP When Eligible Generators’ Real-Time Reserves Schedules for any Operating Reserves Products are Different than their DAM Reserves Schedules.....	166
H.5.1.Real-Time Operating Reserve less than Day-Ahead Operating Reserve:	166
H.5.2.Real-Time Operating Reserve greater than or equal to Day-Ahead Operating Reserve:.....	167
H.6.Hourly DAMAP for Demand Side Resources	167
H.7.RTD Interval Regulation Service Component of DAMAP When Demand Side Resources’ Real-Time Regulation Schedules are Different than their DAM Regulation Schedules.....	168
H.7.1.Real-Time Regulation Service schedule less than Day-Ahead Regulation Service schedule:	168
H.7.2.Real-Time Regulation schedule greater than or equal to Day-Ahead Regulation schedule: ..	168
H.8.RTD Interval Operating Reserves Component of DAMAP When Demand Side Resources’ Real-Time Reserves Schedules for any Operating Reserves Products are Different than their DAM Reserves Schedules	169
H.8.1.Real-Time Reserves schedules less than Day-Ahead Reserves schedules:	169
H.8.2.Real-Time Reserves schedules greater than or equal to Day-Ahead Reserves schedules:....	170
H.9.RTD Interval Regulation Service Component of DAMAP When Limited Energy Storage Resources’ Real-Time Regulation Schedules are Different than their DAM Regulation Schedules	170
H.9.1. Real-Time Regulation Service schedule less than Day-Ahead Regulation Service schedule and Real-Time Regulation Capacity Market Prices greater than Day-Ahead Regulation Capacity Bid price:	170
H.9.2. Real-Time Regulation Service schedule less than Day-Ahead Regulation Service schedule and Real-Time Regulation Capacity Market price less than or equal to Day-Ahead Regulation Capacity Bid price:.....	171

H.9.3.Real-Time Regulation Service schedule greater than or equal to Day-ahead Regulation Service schedule:	172
H.10.Adjustments to Suppliers’ DAM Energy, Regulation, and Operating Reserves Schedules Used for DAMAP Resulting from Supplier Requested Derates of Real-Time Operating Capacity	172
H.10.1.DAM Energy Schedules	172
H.10.2.Regulation Schedules	173
H.10.3.Operating Reserves Schedules	174
APPENDIX I. ANCILLARY SERVICES SUPPLIER SETTLEMENTS	176
I.1.Voltage Support Service Supplier Settlement	176
I.1.1.Generators under contract to supply Installed Capacity	176
I.1.2.Generators not under contract to supply Installed Capacity	176
I.1.3.Cross Sound Cable/ CHPE MTF (if participating as Voltage Support Suppliers).....	176
I.2.Voltage Support Service Supplier Lost Opportunity Cost Settlement	177
I.3.Regulation and Frequency Response Service Day-Ahead Market Settlement.....	179
I.4.Regulation and Frequency Response Service Real-Time Balancing Market Settlement	179
I.4.1.Real-Time Regulation Capacity Balancing Payment	179
I.4.2.Real Time Regulation Movement Payment	180
I.5.Performance-Based Charge to Suppliers of Regulation Service	180
I.6.Regulation Revenue Adjustment Settlement	181
I.6.1.Regulation Up (AGC > RTD)	181
I.6.2.Regulation Down (AGC < RTD)	182
I.7.Under Generation Penalty Settlement	182
I.8.10-Minute Synchronous/Spinning Operating Reserve Day-Ahead Market Settlement	183
I.9.10-Minute Synchronous/Spinning Operating Reserve Real-Time Balancing Market Settlement	183
I.10.10-Minute Non-Synchronous/Spinning Operating Reserve Day-Ahead Market Settlement.....	184

I.11.10-Minute Non-Synchronous/Spinning Operating Reserve Real-Time Balancing Market Settlement.....	184
I.12.30-Minute Operating Reserve Day-Ahead Market Settlement.....	185
I.13.30-Minute Operating Reserve Real-Time Balancing Market Settlement	185
I.14.Quick Start Reserves Service Settlement.....	185
I.15.Black Start Capability Service Settlement for NYISO Bulk Power System Restoration or Transmission Districts other than Consolidated Edison	186
I.16.Black Start Capability Service Settlement for Generators Providing Black Start and System Restoration Services under the Consolidated Edison Transmission District as of October 1, 2005	186
I.17.Black Start Capability Service Settlement for Generators Providing Black Start and System Restoration Services under the Consolidated Edison Transmission District as of November 1, 2012	187
I.18.Overgeneration Charge	189
I.19.Persistent Over-Withdrawal Charges	189
APPENDIX J. ENERGY PURCHASER SETTLEMENTS	191
J.1.Day-Ahead Energy Settlements for Load Serving Entities and Virtual Load	191
J.2.Energy Settlements for Day-Ahead LSEs Providing Energy service to Demand Reduction Buses	191
J.3.Energy Settlements for Real-Time LSEs Providing Energy service to Demand Reduction Buses	192
J.4.Demand Reduction Imbalance Charge to LSEs	192
J.5.Real-Time, Balancing Energy Settlements for LSEs and Virtual Load	193
J.6.Day-Ahead Energy Settlements for LBMP Market Energy Exports.....	193
J.7.Real-time, Balancing Energy Settlements for LBMP Market Energy Exports	194
J.8.Financial Impact Charge (FIC) for LBMP Exports Failing the NYISO Check-out Process	194
APPENDIX K. TRANSMISSION USAGE CHARGE, NTAC, AND TRADING HUB SETTLEMENTS	196
K.1.Day-Ahead Transmission Usage Charge Settlements for Internal, Import, Export, and Wheel Through Bilateral Transactions	196

K.1.1. Without Grandfathered Transmission Rights.....	196
K.1.2. With Grandfathered Transmission Rights	196
K.2. Day-Ahead Replacement Energy for Curtailed Import Bilateral Transactions.....	198
K.2.1. Suppliers who have signed the Market Service Tariff	198
K.2.2. Suppliers who have NOT signed the Market Service Tariff	198
K.3. Real-time, Balancing Transmission Usage Charge Settlements for Internal, Import, Export, and Wheel Through Bilateral Transactions.....	199
K.4. Real-Time Replacement Energy for Curtailed Import Bilateral Transactions	200
K.4.1. Suppliers who have signed the Market Service Tariff	200
K.4.2. Suppliers who have NOT signed the Market Service Tariff	201
K.5. Financial Impact Charge (FIC) for Import Transactions Failing the NYISO Check-out Process ..	201
K.6. Financial Impact Charge (FIC) for Export Transactions Failing the NYISO Check-out Process ..	202
K.7. Financial Impact Charge (FIC) for Wheel Through Transactions Failing the NYISO Check-out Process	202
K.8. NTAC on LSE Withdrawals and Exports, LBMP Market Energy Exports, and Wheels Through ..	203
K.9. Payment to NYPA of NTAC on LSE Withdrawals and Exports, LBMP Market Energy Exports, Wheels Through, and ESR Withdrawals	203
K.10. Day-Ahead Energy Settlements at Trading Hub Point of Injection (Source) Buses	204
K.11. Real-Time Market Energy Settlements at Trading Hub Point of Injection (Source) Buses	204
K.12. Day-Ahead Energy Settlements at Trading Hub Point of Withdrawal (Sink) Buses	205
K.13. Real-Time Market Energy Settlements at Trading Hub Point of Withdrawal (Sink) Buses	205
APPENDIX L. TRANSMISSION CONGESTION CONTRACT (TCC) AND DAM NET CONGESTION RENT SETTLEMENTS	207
L.1. Congestion Rent Payments and Charges to Primary Holders of TCCs	207
L.2. Allocation of DAM Net Congestion Rent.....	207
APPENDIX M. ANCILLARY SERVICES COST RECOVERY AND OTHER CHARGES	210
M.1. OATT Schedule 1 Charge – NYISO Annual Budget Charge	210

M.1.1.Calculation of the NYISO Annual Budget Charge for Transmission Customers Participating in Physical Market Activity	210
M.1.2.Calculation of the NYISO Annual Budget Charge for Transmission Customers Engaging in Virtual Transactions	211
M.1.3.Calculation of the NYISO Annual Budget Charge for Transmission Customers Purchasing Transmission Congestion Contracts	211
M.1.4.Calculation of the NYISO Annual Budget Charge for Transmission Customers Participating in the Special Case Resource Program or Emergency Demand Response Program	212
M.1.5.Calculation of the Credit for Transmission Customers Participating in Physical Market Activity After Recovery of NYISO Annual Budgeted Costs for the Preceding Year	213
M.2.OATT Schedule 1 Charge – NERC and NPCC Charges	214
M.3.OATT Schedule 1 Charge – Non-NYISO Facilities Payment Charge	215
M.3.1.Calculation of the Non-NYISO Facilities Payment Charge for Transmission Customers Based on Withdrawal Billing Units Not Used to Supply Station Power under Part 5 of the NYISO OATT	215
M.3.2.Calculation of the Non-NYISO Facilities Payment Charge for Transmission Customers Based on Withdrawal Billing Units to Supply Station Power under Part 5 of the NYISO OATT	215
M.4.Calculation of the Non-NYISO Facilities Payment Credit	216
M.5.OATT Schedule 1 Charge – Local Reliability Rules G.2 and G.3	216
M.6.OATT Schedule 1 Charge – Residual Costs Payment\Charge	217
M.6.1.Calculation of the Residual Costs Payment/Charge for Transmission Customers Based on Withdrawal Billing Units Not Used to Supply Station Power under Part 5 of the NYISO OATT	217
M.6.2.Calculation of the Residual Costs Payment/Charge for Transmission Customers Based on Withdrawal Billing Units to Supply Station Power under Part 5 of the NYISO OATT	219
M.6.3.Calculation of the Residual Costs Adjustment	220
M.7.Storm Watch Redispatch Costs and Allocation	221
M.7.1.Calculation of Storm Watch Redispatch Cost	221
M.7.2.Allocation of Storm Watch Redispatch Costs to Zone J Withdrawals	221
M.7.3.Allocation of Storm Watch Redispatch Costs Rebate to NYISO Wide Withdrawals	222

M.8.OATT Schedule 1 Charge – Special Case Resources and Curtailment Service Providers.....	222
M.8.1.Calculation of a Charge for the Recovery of Costs for Payments for Special Case Resources and Curtailment Service Providers Called to Meet the Reliability Needs of a Local System.....	222
M.8.2.Calculation of a Charge for the Recovery of Costs for Payments for Special Case Resources and Curtailment Service Providers Called to Meet the Reliability Needs of the NYCA.....	223
M.9.OATT Rate Schedule 1 Charge – Local Reliability Day-Ahead Margin Assurance Payments Charge	223
M.9.1.Calculation of the Local Reliability Day-Ahead Margin Assurance Payment (DAMAP) Charge for Transmission Customers Based on Withdrawal Billing Units Not Used to Supply Station Power under Part 5 of the NYISO OATT	223
M.9.2.Calculation of the Local Reliability DAMAP Charge for Transmission Customers Based on Withdrawal Billing Units to Supply Station Power under Part 5 of the NYISO OATT	224
M.9.3.Calculation of the Local Reliability DAMAP Credit.....	225
M.10.OATT Rate Schedule 1 Charge – NYCA Reliability DAMAP Charge	225
M.10.1.Calculation of the NYCA Reliability DAMAP Charge for Transmission Customers Based on Withdrawal Billing Units Not Used to Supply Station Power under Part 5 of the NYISO OATT.....	225
M.10.2.Calculation of the NYCA Reliability DAMAP Charge for Transmission Customers Based on Withdrawal Billing Units to Supply Station Power under Part 5 of the NYISO OATT	226
M.10.3.Calculation of the NYCA Reliability DAMAP Credit.....	226
M.11.OATT Schedule 1 Charge – Import Curtailment Guarantee Payment Charge.....	227
M.11.1.Calculation of the Import Curtailment Guarantee Payment Charge for Transmission Customers Based on Withdrawal Billing Units Not Used to Supply Station Power under Part 5 of the NYISO OATT	227
M.11.2.Calculation of the Import Supplier Guarantee Payment Charge for Transmission Customers Based on Withdrawal Billing Units to Supply Station Power under Part 5 of the NYISO OATT	228
M.11.3.Calculation of the Import Curtailment Guarantee Credit	228
M.12.OATT Schedule 1 Charge – Local Reliability Bid Production Cost Guarantee Charge.....	229

M.12.1.Calculation of the Local Reliability Bid Production Cost Guarantee (BPCG) Charge for Transmission Customers Based on Withdrawal Billing Units Not Used to Supply Station Power under Part 5 of the NYISO OATT	229
M.12.2.Calculation of the Local Reliability BPCG Charge for Transmission Customers Based on Withdrawal Billing Units to Supply Station Power under Part 5 of the NYISO OATT	230
M.12.3.Calculation of the Local Reliability BPCG Credit.....	230
M.13.OATT Schedule 1 Charge – Local Reliability SCR BPCG Charge	231
M.14.OATT Schedule 1 Charge – NYCA Reliability SCR BPCG Charge.....	231
M.15.OATT Rate Schedule 1 Charge – NYCA Reliability BPCG Charge	232
M.15.1.Calculation of the NYCA Reliability BPCG Charge for Transmission Customers Based on Withdrawal Billing Units Not Used to Supply Station Power under Part 5 of the NYISO OATT.....	232
M.15.2.Calculation of the NYCA Reliability BPCG Charge for Transmission Customers Based on Withdrawal Billing Units to Supply Station Power under Part 5 of the NYISO OATT	233
M.15.3.Calculation of the NYCA Reliability BPCG Credit.....	233
M.16.OATT Schedule 1 Charge – Dispute Resolution Payment/Charge	234
M.17.OATT Schedule 1 Charge – Credit for Financial Penalties	234
M.18.FERC Fee Charge –	235
M.18.1.Calculation of Physical FERC Fee Charge for Transmission Customers Participating in Physical Market Activity.....	235
M.18.2.Calculation of the FERC Fee Charge for Transmission Customers Participating in Non-Physical Market Activity.....	236
M.19.OATT Voltage Support Service Charge -	237
M.19.1.LSEs NOT taking service under Section 5 of the OATT to supply Station Power and Transmission Customers engaging in Wheels Through, Exports and Purchases from the LBMP Market where the Energy is delivered to a NYCA interconnection with another Control Area.....	237
M.19.2.LSEs taking service under Section 5 of the OATT to supply Station Power	238
M.20.OATT Regulation and Frequency Response Service Charge	239
M.20.1.LSEs NOT taking service under Section 5 of the OATT to supply Station Power	239

M.20.2.LSEs taking service under Section 5 of the OATT to supply Station Power	239
M.21.OATT Operating Reserves Service Charge -	240
M.21.1.LSEs NOT taking service under Section 5 of the OATT to supply Station Power and Transmission Customers engaging in Exports and Purchases from the LBMP Market where the Energy is delivered to a NYCA interconnection with another Control Area	240
M.21.2.LSEs taking service under Section 5 of the OATT to supply Station Power	241
M.22.OATT Black Start and System Restoration Service Charge	242
M.22.1.LSEs NOT taking service under Section 5 of the OATT to supply Station Power	242
M.22.2.LSEs taking service under Section 5 of the OATT to supply Station Power	242
M.22.3.LSEs NOT taking service under Section 5 of the OATT to supply Station Power	243
M.22.4.LSEs taking service under Section 5 of the OATT to supply Station Power	243
M.23.Monthly Power Supplier Intermittent Power Resource Forecasting Charge	244
M.24.Rate Mechanism for the Recovery of the Reliability Facilities Charge (“RFC”).....	244
M.25.Rate Mechanism for the Recovery of the Transco Facilities Charge (“TFC”) – Cost Recovery Methodology for All Responsible LSEs Except NYPA	245
M.26.Reliability Must Run	247
M.26.1.Calculation of RMR Charge for an RMR Generator Providing Service Under an Availability and Performance Rate	247
M.26.2.Calculation of RMR Charge for an RMR Generator Providing Service Under a Rate Other Than an Availability and Performance Rate	248
M.26.3.Calculation of RMR Charge for an Interim Service Provider	248
M.27.Recovery for Costs for Demand Reductions Associated with DER Aggregations	249
APPENDIX N. STATION POWER SETTLEMENTS	252

Revision History

Version	Effective Date	Revisions
1.0	09/03/1999	Initial Release
2.0	04/13/2011	All settlements completed and up to date.
2.1	06/01/2011	Changes related to BPCG Enhancement filing of March 30, 2011
2.2	02/13/2012	<p>Incorporation of Technical Bulletins or portions thereof into this manual</p> <ul style="list-style-type: none"> ➤ TB 016 – Rules to Provide Special Balancing Settlements to Certain Intermittent Resources, Certain NYC Steam Turbines, and Generators with Certain Power Purchase Contracts ➤ TB035 – Generator Settlement Rules During Ramping ➤ TB045 – Out of Merit Generation ➤ TB154 – Wind Resource Bidding, Dispatch, and Settlements ➤ TB155 – Special Settlement Rules for Generators Conducting Certain Scheduled Steady-State Tests ➤ TB173 – Settlement Automation of Ramapo PAR, Station 80, and Local Black Start/System Restoration Services ➤ TB177 – Supplemental Resource Evaluation (SRE) Settlement Enhancements ➤ TB179 – Situation-Specific Settlement Rules <p>Remove language regarding obsolete settlement cycle</p> <p>Other minor clarifications and revisions</p>
2.3	06/15/2012	<p>Incorporation of Technical Bulletins or portions thereof into this manual</p> <ul style="list-style-type: none"> ➤ TB 077 – Generator Start-Up Cost Guarantees ➤ TB 082 – Allocation of Uplift Costs to Load and Other Entities Associated with Virtual Trading ➤ TB 203 – Minimum Run Times Extending Past the Commitment Period, Late Day Start Commitments ➤ TB 206 – Weekly Invoicing Procedures
2.4	08/15/2012	<p>Incorporation of Technical Bulletins or portions thereof into this manual</p> <ul style="list-style-type: none"> ➤ TB 125 – Settlement for Day-Ahead Bilateral Transactions Involving Grandfathered Rights ➤ TB 156 – Incremental Cost Recovery for Generating Units Responding to NYSRC Local Reliability Rules I-R3 or I-R5 (Minimum Oil Burn Compensation) ➤ TB 181 – Process for Finalization of Day-Ahead Congestion Shortfall Settlements ➤ TB 182 – Day Ahead Reliability Commitments
2.5	10/17/2012	Updates related to software deployments

Version	Effective Date	Revisions
		<ul style="list-style-type: none"> ➤ Market to Market Coordination Project <p>Note: This manual does not include changes associated with FERC Order 755 (Regulation Compensation) approved by BIC 10/17/12. Due to continuing FERC review, the approved language is subject to change prior to being made effective. The manual will be updated and represented once the final language is known.</p>
2.6	03/13/2013	<p>Updates to reflect Tariff changes</p> <ul style="list-style-type: none"> ➤ Rate Schedule 1 for Non-Physical Market Participants ➤ Billing Issues Project
3.0	07/05/2013	<p>Update to reflect Tariff changes for FERC Order 755</p> <p>Note: These changes were approved by BIC on 10/17/12 but were subsequently pulled from the manual due to continuing FERC review. The additional Tariff filing did not require any changes to this manual</p>
3.1	10/16/2013	<p>Update related to software deployments</p> <ul style="list-style-type: none"> ➤ PTS redesign <p>Updates to reflect Tariff changes</p> <ul style="list-style-type: none"> ➤ Local Black Start program changes <p>Other ministerial changes</p>
3.2	04/16/2014	<p>Updates related to software deployments</p> <ul style="list-style-type: none"> ➤ CTS Preparatory changes <p>Other ministerial changes</p>
3.3	12/29/2014	<p>Updates related to Tariff changes</p> <ul style="list-style-type: none"> ➤ CTS PJM <p>Section 7.2.2.1</p> <ul style="list-style-type: none"> ➤ Updates related to tariff changes: Removal of Non-Firm Point-to-Point transactions <p>Section 8.1.5</p> <ul style="list-style-type: none"> ➤ Update the reference to the 5018 transmission line from 'Branchburg-Ramapo Interconnection' to 'Hopatcong-Ramapo Interconnection' <p>Other ministerial changes</p>
3.4	12/05/2016	<p>General Updates</p> <ul style="list-style-type: none"> ➤ Update references from “Market Mitigation and Analysis department” to “Customer Settlements Department” <p>Updates related to Tariff changes</p> <ul style="list-style-type: none"> ➤ Behind the Meter Net Generation ➤ FERC Fees ➤ CTS NE ➤ Shortage Pricing

Version	Effective Date	Revisions
		<ul style="list-style-type: none"> ➤ Scarcity Pricing ➤ Regulated Transmission Cost Recovery Section 4.1.7.1 <ul style="list-style-type: none"> ➤ Update the reference for PLU calculation from Appendix I Section 7.2.2.2 <ul style="list-style-type: none"> ➤ Update reference from “Market Mitigation and Analysis” to “Customer Settlements” Other ministerial changes
4.0	4/17/2019	General Updates <ul style="list-style-type: none"> ➤ Web page links Updates related to Software Deployments <ul style="list-style-type: none"> ➤ Reliability Must Run ➤ Intermittent Power Resource Forecasting Section 4.2.3.1 <ul style="list-style-type: none"> ➤ Update reference from CBL to ECBL Section 4.1.8 <ul style="list-style-type: none"> ➤ Local Reliability Rule reference change from I-R3 & I-R5 to G.2 and G.3 respectively Deletion of Appendix A and Appendix D Other ministerial changes
5.0	8/23/2019	Global <ul style="list-style-type: none"> ➤ Replacement of Meter Service Provider (MSP) and/or Meter Service Data Provider (MDSP) with Meter Authority General Updates Section 4.3.3 <ul style="list-style-type: none"> ➤ FIC calculation narrative update Other ministerial corrections
5.1	06/05/2020	Updates related to Software Deployments <ul style="list-style-type: none"> ➤ Energy Storage Resources Section 1.3.5 <ul style="list-style-type: none"> ➤ Interest calculation narrative update
5.2	09/07/2020	Updates related to Software Deployments <ul style="list-style-type: none"> ➤ Energy Storage Resources Transmission Service Charges <ul style="list-style-type: none"> ➤ Appendix A ➤ Section 7.8 Export and Wheel Through Transmission Service Charge ➤ Section 10.3 Transmission Service Charge MWh Reporting to Transmission Providers
5.3	11/11/2020	Update related to Software Deployments <ul style="list-style-type: none"> ➤ Enhanced Fast Start Section 4.1.7.1.1
5.4	10/28/2021	Update related to Software Deployments <ul style="list-style-type: none"> ➤ Large Scale Solar ➤ Co-located Storage Resources (CSR)

Version	Effective Date	Revisions
		<ul style="list-style-type: none"> ➤ Accounting Settlements Integration
6.0	04/16/2024	Recertified Update related to Software Deployments <ul style="list-style-type: none"> ➤ DER ➤ RT BPCG for Self committed units placed OOM Other ministerial corrections
7.0	04/30/2026	Sections 5.1.2, 5.1.3, and 5.1.4 <ul style="list-style-type: none"> ➤ Removed the standard power factor range from the payment language Section 5.1.1 and Appendix I.1.3 <ul style="list-style-type: none"> ➤ Added CHPE to sections describing payment methodology for Voltage Support Services, consistent with treatment of the Cross Sound Cable
8.0	07/01/2026	Section 1.3.2, 8.1.8.1, and Appendix M7 <ul style="list-style-type: none"> ➤ Removed references to monthly processing of Thunderstorm Alerts and updated to reflect hourly processing, consistent with software deployments.

Relation of This Manual to NYISO's Tariffs and Agreements

This Accounting and Billing Manual is intended solely for informational purposes and is subject to change. To the extent that information in this Accounting and Billing Manual is inconsistent with the NYISO's tariffs or agreements, the NYISO's tariffs and agreements will control.

1. Settlement and Invoicing Process

This section focuses on the settlement, invoicing, and clearing processes for wholesale market transactions encompassing the NYISO-administered Energy, Transmission Service, and Ancillary Services markets. This manual does not cover settlement, invoicing, or clearing processes for the NYISO-administered Transmission Congestion Contract or Installed Capacity auctions.

1.1. Settlement Processing

Day-Ahead Market (DAM) and Real-Time Balancing (Balancing) Market Energy, Transmission Service, and Ancillary Services settlements are processed daily for the preceding service day's market activity, with the exception of Station Power program and Intermittent Power Resource Forecasting cost recovery settlements, which are processed monthly. Settlement results and determinant data are published to the NYISO's Decision Support System, which is a Web-enabled data warehouse that avails this data to Market Participants through pre-formatted, settlement-specific reports and queries that may be configured by each Market Participant. Settlements are invoiced on a weekly basis, as detailed later in this manual. Settlements are subsequently resettled to provide for adjustments to metering data and any estimates used in previous invoices.

1.1.1. Processing Prior to Initial Invoice Issuance

This section focuses on the processing of settlements prior to their initial invoicing.

1.1.1.1. Initial Processing

Settlements are processed daily for Day-Ahead Market (DAM) and Real-Time Balancing (Balancing) Market Energy, Transmission Service, and Ancillary Services transaction for the preceding service day. Two days after the service day, settlement results and determinant data are published to the NYISO's Decision Support System, which is a data warehouse that avails this data to Market Participants through pre-formatted, settlement-specific reports and queries that may be configured by each Market Participant.

1.1.1.2. Reprocessing Prior to Initial Invoicing

Settlements may be based in whole or in part on estimates. Hourly revenue quality sub-zonal transmission tie-line interconnection and Generator metering data used for Balancing Market settlements are due to the NYISO one business day after the service day. Corrections to energy and ancillary services prices are due within four days of the service day. Prior to invoicing, the NYISO may reprocess settlements for any service day to incorporate updates to settlement determinant data (e.g., metering data, prices,

flagging of Generators dispatched out of economic order, transaction schedules, etc.).

The NYISO will make every effort to accommodate data updates prior to each invoice. In the event that the timing of requests to update data jeopardizes the timely issuance of invoices, the inclusion of such updates or their deferral to the subsequent resettlement/true-up of the service month will be at the discretion of the NYISO.

1.2. Weekly Invoice Processing

The NYISO invoices DAM and Balancing Market Energy, Transmission Service, Ancillary Services, TCC Auction results, TCC Congestion rents, and a pro-rata portion of the most recent Installed Capacity auction settlements on a weekly basis. The calculation of the pro-rata portion of the most recent Installed Capacity auction settlements to be included in a weekly invoice will be based on the number of billing days in the Complete Week Settlement Period or Stub Week Settlement Period that begins a month as a percentage of the days in the month. The billing data reflecting an issued weekly invoice will be versioned as 0.5.

Intermittent Power Resource Forecasting cost recovery and Station Power settlements are handled through the monthly invoice. See section 1.3 for additional details.

Invoices for Transmission Service Charges (TSCs) to Load Serving Entities serving load within the NYCA and Transmission Customers with energy exports or Wheels Through and out of the NYCA are issued by the respective Transmission Owners and are, therefore, not invoiced by the NYISO (see Appendix A).

Settlements in connection with the purchase and sale of Transmission Congestion Contracts and the allocation of Net Auction Revenues to Transmission Owners are conducted by the NYISO in accordance with the separate settlement timeframe set forth in NYISO procedures, and are, therefore, not part of the weekly or monthly invoice.

1.2.1. Settlement Period

The Complete Week Settlement Period used for a weekly invoice will be the seven day period that runs from Saturday to Friday, as long as all days of the seven day period are within the same month. The Complete Week Settlement Period will not include days from two different months. If there are any days in a Saturday to Friday period that are from another month, the Saturday to Friday period will be divided into two separate Stub Week Settlement Periods.

If a month begins on a day other than Saturday, the Stub Week Settlement Period that begins the month will include only the days from the first day of that month until the first Friday of that month. The Stub Week Settlement Period that begins the month will be the settlement period for the first weekly invoice for

that month.

If the month ends on a day other than Friday, the Stub Week Settlement Period that concludes the month will include only the days from the last Saturday of that month until the last day of that month. The Stub Week Settlement Period that concludes the month will be included on the monthly invoice for that month as part of the initial monthly settlement. The NYISO will not issue a separate weekly invoice for a Stub Week Settlement Period that concludes a month.

1.2.2. Invoice Format

Weekly invoices are rendered electronically through the NYISO's Web-enabled invoicing application. Hard-copy invoices are not issued to Market Participants. Customers are responsible for retrieving their invoices from the NYISO's Website upon the NYISO's notice of invoice posting. Customers access their invoices through a password protected login established through the NYISO Stakeholder Services at (518) 356-6060 or *email to:* Stakeholder_Services@nyiso.com .

Customers are responsible for keeping all contact information current with the NYISO and should immediately notify the NYISO of any changes to this information. The billing contacts established for each customer during the registration process are included on an email notification list, which is the method through which the NYISO notifies the marketplace of invoice issuance and invoice-related matters. Market Participants are notified of invoice postings via email notifications after invoices have been posted and are available to be retrieved from the NYISO's Website. The email notification identifies the periods being invoiced and the clearing dates that payments are due to and from the NYISO Clearing Account. Customers are provided access to their invoices only through their respective password-protected logins.

1.2.3. Invoicing Schedule

The NYISO issues weekly invoices on or about Wednesday of the week following either a Complete Week Settlement Period or a Stub Week Settlement Period that begins the month. The NYISO may issue an invoice on a day other than Wednesday to avoid issuing both a weekly invoice and a monthly invoice on the same date, as described in section 1.3.3 below, or to accommodate holidays. A weekly invoicing schedule is maintained by the NYISO and can be accessed through the "Processing & Invoice Schedules" folder on the following Webpage:

<https://www.nyiso.com/billings-and-settlements>

The schedule details the date that each invoice is scheduled to be issued, the days to be included in the invoice, and the dates that payments are due to and from the NYISO Clearing Account.

1.2.4. Clearing (Payment)

Market Participants are not permitted to net the balances of invoices issued in a given month. Payments due to the NYISO are to be deposited in the NYISO's Clearing Account by the close of business on the first banking day common to all Customers that falls on or after the second business day after the date on which the weekly invoice is issued by the NYISO (the requital date). Payments due from the NYISO are paid on the first banking day common to all Customers that falls on or after the second business day after the due date for Customer payments (the disbursement date). All payments due to or from the NYISO are to be made by either wire transfer in immediately available funds or other electronic funds transfer acceptable to the NYISO and acknowledged in writing by the Market Participant. Prepayments made by Market Participants to manage their credit requirements are applied as adjustments to each respective invoice.

1.3. Monthly Invoice Processing

The NYISO invoices Intermittent Power Resource Forecasting cost recovery, and Station Power settlements as well as DAM and Balancing Market Energy, Transmission Service, Ancillary Services net of any amounts previously invoiced through the weekly invoice, on a monthly basis. The results of any Load shifting or true-ups that would have been included in the normal monthly Installed Capacity settlement amount prior to the implementation of weekly invoicing along with any pro-rata portion of the monthly auction results attributable to the Stub Week Settlement Period that concludes a month will also be included in the monthly invoice. The billing data reflecting an issued monthly invoice will be versioned as follows:

- Initial monthly billing period = version 1
- 4 Month True-up period = version 2
- Final Bill Closeout period = version 3

1.3.1. Invoice Format

Monthly invoices are rendered electronically through the NYISO's Web-enabled invoicing application in the same manner described in section 1.2.1 above.

1.3.2. Invoice Adjustments

On the monthly invoice only, the NYISO may apply adjustments to an invoice to: (a) adjust settlements that have been computed incorrectly due to software or data errors that could not be resolved in time for timely invoicing; (b) settle disputes or settlements emanating from regulatory or legal proceedings whose provisions cannot be accommodated through the NYISO's settlement software; or (c) apply settlements to the invoice that have not been incorporated into the NYISO's settlement software. Adjustments applied to

an invoice are itemized and reported through the Consolidated Invoice and the Decision Support System. Manual Adjustments include, but are not limited to the following:

- Quick Start Cost Charges and Credits
- NERC ERO Charges
- Attachment N Reallocations
- Disputes and Penalties

The true-up process provides for the resettlement of invoice adjustments that were initially based on estimated billing units. To accomplish this, adjustments that were applied to the prior invoices of a service month based on estimated billing units are automatically backed-out and resettled in subsequent true-up invoices to provide for the reallocation of adjustment amounts in accordance with changes in the Market Participants' billing units, with interest applied to any changes in the adjustment reallocations accruing from the payment date of the service month's initial invoice (i.e., the first due date after service was rendered). The exception to this rule is any adjustment applied quarterly to recover charges: (a) of the NERC for its service as the Electric Reliability Organization ("ERO") for the United States and (b) of the Northeast Power Coordinating Council: Cross-Border Regional Entity, Inc., or its successors, incurred to carry out functions that are delegated by the NERC and related to ERO matters. Adjustments recovering these costs are applied to the monthly invoice issued four months following issuance of the monthly invoice for the service month that immediately followed the NYISO's receipt of the ERO's quarterly invoice.

1.3.3. Invoicing Schedule

The NYISO issues monthly invoices within five business days after the first day of the month following the service month. A monthly invoicing schedule is maintained by the NYISO and can be accessed through the Billing and Settlements webpage under the "Processing & Invoice Schedules" folder on the following Webpage:

<https://www.nyiso.com/billings-and-settlements>

The schedule details the date that each invoice is scheduled to be issued, the service months that are to be included in the invoice, and the dates that payments are due to and from the NYISO Clearing Account.

In the event that the issuance date for a monthly invoice falls on a Wednesday, a weekly invoice issued that week will be issued on Tuesday. This process will clearly delineate the billing results associated with the monthly invoice and the weekly invoice.

1.3.4. Consolidated Invoicing

The NYISO invoices monthly settlement balances on a consolidated basis. The monthly invoice,

typically comprises: the initial monthly invoicing of settlements for the service month immediately preceding the invoice issuance, comprised of resettlement of any day previously settled on a weekly invoice and the initial settlement of any days comprising a Stub Week Settlement Period that concludes the month; the resettlement of the service month initially invoiced four months prior, and close-out settlements for months that have gone through their review and correction periods and have been posted for a twenty-five day review period prior to such invoicing.

As previously stated, settlements may be based in whole or in part on estimates. Prior invoices for service months that have been based on estimates are subject to resettlement in order to adjust estimates to actual values or to revise such estimates.

The first resettlements may appear on the monthly invoice if any of the estimates used for the dates already invoiced on Weekly invoices have changed. Resettlements are also performed on the invoice issued four months after the issuance of the service month's initial invoice. Finally, the NYISO posts an advisory close-out invoice for a period of twenty-five days for Market Participants to review the NYISO's implementation of corrections or adjustments to their invoices prior to the NYISO issuing the close-out invoice for the service month.

Payments due to or from the NYISO resulting from the resettlement of a service month are subject to interest. Balances for each service month contained in the monthly invoice are netted to arrive at a net amount due to or from the Customer.

The NYISO may net any payments due a Customer or overpayments by a Customer, including interest owed a Customer, against current amounts due from the Customer or, if the Customer has no outstanding amounts due, the NYISO may pay to the Customer an amount equal to the overpayment.

1.3.5. Interest Payments and Charges

Interest payments and charges are calculated in accordance with the methodology specified for interest on refunds in the FERC's regulations at 18 C.F.R. § 35.19a (a)(2)(iii).

Interest payments and charges are calculated on those amounts in the customer's invoice that are not paid on the due date established by the NYISO tariffs. Interest on unpaid amounts is calculated from the due date of the invoice until the date of payment. For payments due to the NYISO, interest begins to accrue from the requital date. For payments due from the NYISO, interest begins to accrue from the disbursement date. For invoices that are a result of regulatory or legal proceedings that stipulate direct invoicing outside of the normal invoicing cycle, interest accrues from the payment dates identified in such rulings or settlement agreements. Invoices will be considered as having been paid on the date of receipt by the NYISO.

In addition, resettlement balances are subject to interest. The beginning date used in the calculation is the banking date of the billing period's issued initial invoice(V1). The 'Settlement Subtotal' of the billing period's resettlement amount (V2, V3, etc.) is used to determine the ending date of the interest calculation. If the 'Settlement Subtotal' is negative (Due to NYISO); use the requital date of the resettlement invoice. If the 'Settlement Subtotal' is positive (Due from NYISO); use the disbursement date of the resettlement invoice. These banking dates are located on the Monthly Invoicing Schedule, which can be accessed through the Billing and Settlements webpage under the "Processing & Invoicing Schedules" folder located at:

<https://www.nyiso.com/billings-and-settlements>

1.3.6. Clearing (Payment)

As previously described in section 1.2.4, Market Participants are not permitted to net the balances of invoices issued in a given month. All invoices are to be paid in full through the NYISO's Clearing Account. As with weekly invoicing, payments due to the NYISO for monthly invoices are to be deposited in the NYISO's Clearing Account by the close of business on the requital date. Payments due from the NYISO are paid on the disbursement date. All payments due to or from the NYISO are to be made by either wire transfer in immediately available funds or other electronic funds transfer acceptable to the NYISO and acknowledged in writing by the Market Participant. Prepayments made by Market Participants to manage their credit requirements are applied as adjustments to each respective invoice.

1.4. Resettlement (i.e., True-ups)

In order to update settlements based on estimates with actual values or further refine estimates, resettlements (a.k.a. true-ups) are performed four months after the issuance of the initial invoice for each service month

1.4.1. Meter Data Revision Sunset Provisions

Energy, Ancillary Services, and Station Power Program settlements are based on metered energy injections, sub-zonal transmission tie-line interconnection flows, and withdrawals. The metering systems that measure these quantities are maintained by the Meter Authorities (as defined in the Revenue Metering Requirements Manual, i.e., Member Systems and Meter Services Entities). The processing and transmission of meter data to the NYISO are performed by the Meter Authorities.

Due to the susceptibility of metering systems to periodic failure or interruption in associated communications networks, the NYISO administers a meter data correction process to facilitate the

identification and correction of meter data errors and gaps. Hourly revenue-quality meter data for Tie-line interconnections, Generators, and sub-zone Load meter data provided by Transmission Owners may be updated up to sixty (60) days after the issuance of a service month's initial monthly invoice. Corrections to such meter data after the cutoff at day-60 may be accommodated only through an order of the FERC or court of competent jurisdiction.

Load Serving Entities (LSEs) typically comprise an aggregation of multiple retail consumers. Retail consumption data availability is subject to the respective Meter Authorities' retail meter reading cycles. As a result, finalized LSE metering data is subject to revision up to one hundred fifty (150) days after the issuance of a service month's initial monthly invoice. Corrections to LSE meter data after the day-150 cutoff may be accommodated only through an order of the FERC or court of competent jurisdiction.

Any deadline that falls on a Saturday, Sunday or holiday for which the NYISO is closed will be observed on the NYISO's next business day.

1.5. Close-out Invoice and Resettlement Sunset Provision

Market Participants have a five-month period after the posting of a service month's initial invoice to review and challenge their settlements, with the exception of metering data, which is limited to challenge and revision within the time frames detailed above.

After the expiration of the applicable review and challenge periods, the NYISO must resolve all challenges and post an advisory close-out invoice within two months. In the event that challenges cannot be resolved within the two-month period, the NYISO may declare an Extraordinary Circumstance, which provides for the extension of the resolution period up to an additional four months, at which time the NYISO posts an advisory close-out invoice.

Market Participants have twenty-five (25) days to review an advisory close-out invoice for errors made by the NYISO in implementing resolutions to challenges. If no implementation errors are identified within the twenty-five-day review period, the NYISO will issue a close-out invoice for the service month. In the event, however, that an error in implementation is identified, the NYISO must correct such error within one month and repost the advisory close-out invoice for an additional twenty-five-day review period. In the event that an error is identified during the second twenty-five-day review period in the NYISO's corrections to the implementation errors identified during the initial twenty-five-day review period, the NYISO will have one month to correct such errors and then will issue a close-out invoice.

Close-out invoice balances due to or from the NYISO are subject to interest, as previously described. Further adjustments to settlements for a service month after issuance of its close-out invoice may be

accommodated only through an order of the FERC or court of competent jurisdiction.

Any deadline that falls on a Saturday, Sunday or holiday for which the NYISO is closed will be observed on the NYISO's next business day.

1.6. Settlement and Invoice Support

Settlement and invoice details, as well as other information to assist in reconciling those invoices, are made available to Market Participants through the NYISO's Market Access Login webpage. This page is essentially a Web portal providing access to a number of applications which allow Market Participants to view and/or download settlement and invoice details.

1.6.1. Bidding and Scheduling System

The Bidding and Scheduling System is an interface for Market Participants to submit Bids to schedule transmission service, energy purchases, and sell energy and ancillary services. Market Participants can view their Bid and schedule data for a period of ten days after the service day.

The Bidding and Scheduling System is comprised of two applications both accessed through the Market Access Login. The following webpage provides the links to market applications:

<https://www.nyiso.com/market-access-login1>

Further instructions for navigating the Bidding and Scheduling System applications are available in the NYISO's *Market Participant User's Guide*, posted on the NYISO's Website at:

<https://www.nyiso.com/manuals-tech-bulletins-user-guides>

1.6.2. Settlement Data Applications

The Settlement Data Applications provide Market Participants with the ability to view, and in some cases update, meter data, Invoices, and other supporting details.

The Settlement Data Applications are comprised of two applications accessed through the Market Access Login webpage at:

<https://www.nyiso.com/market-access-login1>

1.6.2.1. Customer Settlements Interface

The Customer Settlements Interface (CSI) application provides Market Participants with the ability to view, and in some cases update, their invoice reports, daily reconciliation data, working capital data, and metering reconciliation data for which they have permissions.

The CSI is accessed by selecting the Customer Settlements Interface item from the Settlement Data Applications list. The specific modules within the application are detailed below.

1.6.2.1.1. Consolidated Invoice

The NYISO issues monthly electronic invoices through its Consolidated Invoice module. The Consolidated Invoice module provides Market Participants with: (a) a summary of monthly settlement activity, by market sector, for each month being invoiced, which can be downloaded in either PDF or XLS format; (b) a summary of monthly settlement history, by settlement type, for each month being invoiced, which can be downloaded in XLS format; (c) a summary and descriptions of any adjustments that have been applied to the invoice, which can be downloaded in XLS format; (d) detail on any prepayment activity for the Market Participant pertaining to the monthly invoice, which can be downloaded in XLS format; (e) details on ICAP transactions for the Market Participant for the initial month invoiced, which can be downloaded in XLS format; and (f) details of any Bad Debt Loss Activity included on the Market Participants invoice, which can be downloaded in XLS format. As each day's settlements are processed throughout the month, Market Participants may observe through the Consolidated Invoice application their accumulated month-to-date settlement positions, which are labeled as a "DRAFT INVOICE" until the invoice is officially rendered.

The Consolidated Invoice module is accessed by selecting the Consolidated Invoice target once logged in through CSI.

1.6.2.1.2. Daily Reconciliation

The Daily Reconciliation module provides monetary and megawatthour (MWh) balances for each Customer's transactions for a single day or a period of consecutive days within a given month. The data queried can be downloaded in XLS format.

The Daily Reconciliation module is accessed by selecting the Daily Reconciliation target once logged in through CSI.

1.6.2.1.3. Working Capital

The Working Capital module provides Market Participants with a statement of activity for their Working Capital Account balances for a specified period of time which can be downloaded in XLS format.

The Working Capital module is accessed by selecting the Working Capital target once logged in through CSI.

1.6.2.1.4. Metering Reconciliation

The Metering Reconciliation module provides Meter Authorities with the ability to view and update

hourly revenue meter data for generators, sub-zonal transmission tie-line interconnections, and LSE buses. Hourly sub-zonal loads are also accessible through this module. Additionally, Market Participants have the ability to view the data that applies to them. The reports can be downloaded in XLS format.

The Metering Reconciliation module is accessed by selecting the Metering Reconciliation target once logged in through CSI.

For Behind-the-Meter Net Generation Resources, the Meter Authority must report hourly revenue meter values for all injections measured at the net facility meter on the generator PTID used for the facility.

For Behind-the-Meter Net Generation Resources, the Meter Authority must report hourly revenue meter values for all withdrawals measured at the net facility meter as part of the load bus (or buses) for which the Behind-the-Meter Net Generation Resource is registered.

In the event that the Meter Authority cannot measure hourly injection and withdrawal values independently at the facility net meter, the Meter Authority shall report a net hourly value. For hours in which the net hourly value indicates a net injection at the net facility meter, report the value of the generator's PTID. Alternatively, for hours in which the net hourly value indicates a net withdrawal at the facility net meter, report the value as part of the load bus (or buses) for which the Behind-the-Meter Net Generation Resource is registered.

A Meter Authority shall not report a negative hourly value (withdrawal) on the Behind-the-Meter Net Generation Resource generator PTID under any circumstances.

1.6.2.2. Additional instruction availability

Further instructions for navigating the Settlement Data applications are available in the NYISO's *Settlement Data Applications User's Guide*, posted on the NYISO's Website at:

<https://www.nyiso.com/manuals-tech-bulletins-user-guides>

1.6.3. Decision Support System (DSS)

Dispatch-interval (nominally five-minute), hourly, daily, weekly, and monthly settlement details may be accessed through the NYISO's Decision Support System (DSS). The DSS is a data warehouse application that provides registered and approved Market Participants with: (a) the capability to view or download preformatted, settlement-specific reports and (b) a query tool which allows Customers to create their own reports.

The DSS is accessible only to registered and approved Customers through the Market Access Login webpage at:

<https://www.nyiso.com/market-access-login1>

Instructions for navigating the DSS application are available through training sessions, conducted periodically by the NYISO. A number of documents are also accessible once logged into the DSS which provide guidelines for mapping settlement results and Consolidated Invoice values to the data elements stored in the DSS.

1.6.4. OASIS

The NYISO administers an Open Access Same-Time Information System (OASIS) that provides direct access to Market and transmission grid information, inclusive of transmission system transfer capability, day-ahead, hour ahead, and dispatch-interval LBMPs, Market Clearing Prices for Ancillary Services, and fixed rates used in settlements [e.g., monthly NTAC rate, monthly Open Access Transmission Tariff (OATT) and Market Administration and Control Area Services Tariff (Services Tariff or MST) SSC&D rates; annual Voltage Support Service rates, etc.]. NYISO's OASIS is viewable by accessing the various tabs of the Market & Operations Data section of the web page at:

<https://www.nyiso.com/energy-market-operational-data>

Information accessible from the NYISO's OASIS is viewable through Web browser and downloadable in multiple file formats (e.g., PDF, csv, html, etc.).

2. Market Participant Responsibilities and Controls

The NYISO's processing of transactions and the controls surrounding the processing of transaction data were designed under the assumption that certain internal controls would be implemented by Market Participants. The *Market Participants User's Guide (MPUG)* describes the nature of such controls that should be administered by Market Participants to complement the NYISO's controls. The list detailed in the *MPUG* should not be viewed as an exhaustive list of all internal controls that should be applied by Market Participant organizations. Other internal controls may be required at Market Participant organizations. Market Participant auditors should consider whether the internal controls detailed in the *MPUG* are in place and whether additional controls are warranted.

3. Settlement and Invoice Inquiries, Challenges, and Dispute Processes

3.1. Submission of Inquiries, Challenges, and Disputes

All settlements-related inquiries and challenges to settlements and settlement determinant data, and disputes should be submitted to the NYISO through Stakeholder Services, with the exception of requests to initiate the Expedited Dispute Resolution process, which are submitted directly to the Chief Financial Officer, as well as Stakeholder Services.

Stakeholder Services is available to address routine business inquiries from 8:00 a.m. until 5:00 p.m.(EST), Monday through Friday and can be contacted by emailing Stakeholder_Services@NYISO.com, or by calling 518-356-6060. Stakeholder Services is also available 24x7x365 to address urgent, real-time issues, such as problems with access to the MIS. In the event that system conditions preclude NYISO staff immediately answering this telephone line, the caller can either leave a message or try again within a few minutes. Market Participants should submit inquiries, challenges, and disputes to Stakeholder Services via email to Stakeholder_Services@NYISO.com or through the NYISO's Web-enabled Member Community at: <https://nyiso.force.com/MemberCommunity/s/login/>, with the exception of requests to initiate the Expedited Dispute Resolution Process, which must be submitted directly to the Chief Financial Officer.

Settlement-related inquiries should be sufficiently supported to facilitate a timely, relevant response to Customers' concerns. Inquiries and challenges should be supported by a thorough description of the issue(s) in question and the following information, where applicable:

- Invoice date, for inquiries/challenges pertaining to invoices;
- Adjustment IDs, for inquiries/challenges pertaining to invoice adjustments;
- Service date(s) and hour(s) for specific transaction(s) in question;
- Relevant LSE and LSE Bus names and point identifiers (PTIDs);
- Relevant Generator Bus names and point identifiers (PTIDs);
- Respective Transaction IDs for inquiries/challenges pertaining to LBMP Energy imports or exports;
- Respective Transaction IDs for inquiries/challenges pertaining to Internal, Import, Export, and Wheel Through Bilateral Transaction Transmission Service;
- Copies of the relevant settlement-specific reports accessible from the NYISO's Decision Support System (listed in Appendix A), with the settlements and/or billing determinant data in question highlighted; and
- Tariff references, whenever possible.

3.2. Inquiries, Settlement Challenges, and Updates Prior to Initial Invoicing

Issues that are most likely to be resolved prior to the issuance of the initial invoice for a billing period

pertain to settlement determinant data. The NYISO performs analyses designed to identify and correct certain anomalous performance and schedule data. In most instances, data corrections are made prior to the initial processing of a service day's settlements. Once settlements have been processed and publicly posted, Market Participants may identify and challenge the accuracy of this information. Whenever possible, the processing of data corrections is accommodated in order to render an accurate invoice at each invoicing opportunity. The NYISO exercises discretion over the incorporation of data corrections based on the materiality of the financial impacts from excluding the corrections versus the disruption of the settlement cycle that may be required to incorporate the corrections. Any data corrections not included in an invoice are appropriately tracked and incorporated into the next available invoicing of the affected service month's transactions.

3.2.1. Generation, Transmission Line, and Sub-Zone Load Meter Data Management

Generator, transmission line interconnection, and sub-zone Load meter data are required for settlement of Load Serving Entities' and Generators' Energy and Ancillary Services transactions. The NYISO OATT Sections 2.7.4.2.1 and 2.7.4.2.2 and Market Administration and Services Tariff Sections 7.4.1.1 and 7.4.1.2 detail the time periods during which sub-zone Load, transmission line interconnection and Generator hourly billing quality meter data may be revised and challenged. The NYISO's metering requirements/standards are detailed in the NYISO *Revenue Metering Requirements Manual*.

3.2.1.1. Responsibility for Metering Data Accuracy

The TOs are charged with maintaining revenue quality metering systems for transmission tie-line interconnections between and Generators within their respective transmission districts and the timely reporting of this data to the NYISO. It is the expectation of the NYISO that the TOs maintain reasonable and appropriate process controls over the accuracy and completeness of this data. The NYISO's *Revenue Metering Requirements Manual* provides administrative and processing guidelines, as well as the hardware specifications, to which sub-zonal transmission line interconnection and Generator hourly billing quality metering systems should be maintained.

The NYISO administers the processes through which metered data is submitted by the TOs and performs certain substantive testing to assist the TOs in identifying potential erroneous or missing data. The NYISO coordinates the timely reconciliation and correction of such erroneous or missing data with the TOs.

3.2.1.2. Meter Data Submission, Analysis, and Revisions

By noon the first business day following a service day, the TOs are required to submit all available sub-

zonal transmission tie-line interconnection, Generator, and sub-zone Load hourly meter data to the NYISO. The procedural guidelines and the file formats that are to be used by the TOs in submitting data are specified in the *Settlements Data Applications User Guide*, posted to the NYISO Website at:

<https://www.nyiso.com/manuals-tech-bulletins-user-guides>

The NYISO Settlements Department does not administer a seven-day a week operation; therefore, data analyses are performed by the NYISO on the first business day following the service day. At or about noon the first business day following the service day, the NYISO locks down the SDX database to prevent further metering data updates while performing analyses to assist the TOs in identifying potential erroneous or missing data.

By approximately 14:00 the first business day following the trade day, the NYISO will have identified, compiled, and reported potential sub-zonal transmission tie-line interconnection and Generator hourly meter data anomalies and missing hourly sub-zone Load data to the respective TOs for their review and reconciliation. In the event that observed anomalies may result in materially misstated settlements, the NYISO may interrupt the processing of settlements for the affected service day until such anomalies can be resolved with the respective TOs. If anomalies for a service day that was processed and posted during a non-business day which have resulted in materially misstated settlements, the NYISO will promptly notify the marketplace and diligently pursue data corrections with the respective TOs and schedule the reprocessing and reposting the affected service day's settlements as soon as practicable.

On or about two business days after a service day has been analyzed, the SDX database is unlocked to allow the TOs to submit further sub-zonal transmission tie-line interconnection, Generator, and sub-zone Load metering data updates. The database is relocked at day's end. The NYISO re-performs the analyses to assist the TOs in identifying any additional anomalies that may have been introduced into the database during the TOs' updates. Observed anomalies are managed through the aforementioned processes, in an iterative fashion.

Prior to the issuance of a service month's initial invoice, the TOs may be afforded the opportunity to submit additional data or to revise data already submitted. After each instance when the SDX database has been unlocked to allow data updates, the NYISO re-performs the analyses to assist the TOs in identifying any additional anomalies that may have been introduced into the database during the TOs' updates. Observed anomalies are managed through the aforementioned processes, in an iterative fashion.

3.2.1.3. Challenges to Transmission Interconnection, Generator, and Sub-Zone Load Metering Data Prior to Invoicing
Up to and including the last day of a service month, TOs and Suppliers may challenge the accuracy of

their respective transmission interconnection and Generator hourly meter data for the purposes of the initial monthly invoice. Challenges to sub-zonal transmission tie-line interconnection, Generator, and sub-zone Load hourly meter data should be submitted to the NYISO at: TSA@nyiso.com.

The NYISO issues monthly invoices within five business days after the first day of month following the service month; therefore, the submission of additional or corrected sub-zonal transmission tie-line interconnection, Generator, and sub-zone Load hourly meter data for inclusion in the initial monthly invoice beyond two business days of the end of the service month is at the NYISO's discretion.

3.2.2. Allocation of Sub-Zonal Loads to LSEs and LSE Meter Data Management Prior to Initial Invoicing

The NYISO OATT Sections 2.7.4.2.1 and 2.7.4.2.2 and Services Tariff Sections 7.4.1.1 and 7.4.1.2 detail the time periods during which LSE hourly billing quality metering data may be revised and challenged.

3.2.2.1. Sub-Zonal Load Allocation to LSEs for Initial Settlement

LSEs are usually an aggregation of multiple retail customers. As a result, LSEs' consumption is determined by the aggregation of the meter readings of their retail customers, as adjusted by the TOs according to their respective retail access tariff provisions for load profiling, distribution loss allocations, and unaccounted-for-energy (UFE) allocations. This information is seldom available until retail customer meter readings have been obtained well after the NYISO's issuance of a service month's initial monthly invoice. Since TOs' retail meter reading cycles span months, the NYISO's market design incorporates an estimation process to render an invoice for wholesale market purchases within five business days after the first day of the month following the service month, with an opportunity to "true-up" LSE withdrawals at four months after the issuance of a service month's initial invoice. The estimation process involves determining how much electricity is consumed within each TO's transmission district (i.e., sub-zone) and then allocating the sub-zonal withdrawal to the LSEs within the respective sub-zones.

The first step in allocating sub-zonal withdrawals to each LSE within a particular sub-zone is to determine the amount of electricity consumed within each sub-zone. Sub-zonal withdrawals are derived from the metering data for the transmission district (sub-zonal) transmission tie-line interconnections and Generator injections within each sub-zone, or as computed by the respective TOs and submitted to the NYISO, adjusted for transmission losses. Sub-zonal withdrawals are computed by adding the net transmission interconnection flows into a sub-zone to the total amount of energy injected into the sub-zone by Generators operating within the sub-zone, or are computed by the respective TOs and submitted to the NYISO, and subtracting the sub-zonal transmission losses. This calculation is performed for each Real-Time Dispatch (RTD) interval, each of which is nominally five minutes in length. The metering systems that

provide the real-time data are not typically revenue grade. As a result, the NYISO adjusts this data to revenue quality values using the transmission interconnection and Generator hourly revenue quality metering data submitted, as described above. Hourly sub-zonal withdrawals are computed in the same way as those at the RTD interval level.

Each RTD interval sub-zonal withdrawal value is adjusted by multiplying by the ratio of the hourly sub-zonal withdrawal, computed using revenue quality metering data, and the hourly integration of the RTD interval sub-zonal withdrawals over the hour. The hourly integration of RTD interval withdrawals is a time- and load-weighting of the RTD interval sub-zonal withdrawals over the hour. Each RTD interval withdrawal is multiplied by the length of the RTD interval (in seconds) and then divided by 3,600 seconds per hour, the results of which are summed over the hour to arrive at the hourly integrated real-time sub-zonal withdrawal.

The NYISO's market design methodology for allocating sub-zonal withdrawals to individual LSEs within each sub-zone for initial invoicing is based on the hourly forecasts provided by the LSEs in their hourly DAM Bids. For each sub-zone, the forecasted hourly consumptions of each LSE are totaled to determine a total hourly consumption forecast for the sub-zone. The hourly sub-zonal loads, as described above, are allocated to each LSE according to the ratio of their respective hourly forecasted withdrawal to the total of the forecasted hourly withdrawals submitted by all LSEs within a particular sub-zone.

Some LSEs are equipped with hourly interval recording metering systems. By noon the day following the service day, LSEs have the ability to update their hourly load forecasts with better estimates of their withdrawals, and LSEs equipped with interval recording metering systems (e.g., municipalities with metered points of demarcation) may update their forecast with actual metered withdrawals. LSEs that are designated as providing actual hourly metering data are excluded from the sub-zonal load allocation process described above, and their metered consumptions are excluded from the denominator of the allocation ratio for the service month's initial invoicing.

3.3. Settlement and Invoice Challenges

Settlement information is subject to review, comment, and challenge by Customers and correction or adjustment by the NYISO for errors in arithmetic, computation, or estimation at any time for up to five (5) months from the date of the initial settlement, subject to the following limitations:

- Suppliers, Meter Authorities may review, comment on, and challenge Generator and sub-zonal transmission tie-line interconnection metering data for fifty-five (55) days from the date of the initial invoice for the month in which service is rendered. Following this review period, the

NYISO has five (5) days to process and correct Generator and sub-zonal transmission tie-line interconnection metering data, after which time it will be finalized.

- Customers may review, comment on, and challenge the LSE bus metering data for one hundred forty-five (145) days from the date of the initial invoice for the month in which service is rendered. Following this review period, the NYISO has five (5) days to process and correct the LSE bus metering data, after which it will be finalized.

At ninety (90) days from the date of the initial invoice, the NYISO will have posted updated advisory settlement information for the service months' four-month resettlement. Customers may review, comment on, and challenge this settlement information up to approximately five business days prior to the issuance of the four-month resettlement. At approximately five business days prior to the issuance of the four-month resettlement, the NYISO temporarily suspends further updates to process the resettlement. Further updates are permitted once the four-month resettlement invoice has been issued.

Following the NYISO's issuance of an updated corrected invoice, Customers may continue to review, comment on, and challenge settlement information, excepting Generator, tie line, and LSE bus metering data, until the end of the Customers' review and challenge period. Any deadline that falls on a Saturday, Sunday or holiday for which the NYISO is closed will be observed on the NYISO's next business day.

The NYISO provides a number of courtesy emails which serve as reminders of some deadlines as noted in subsequent sections. These emails are sent to the Billing, Accounting, and Credit Policy Working Group and Billing and Customer Settlements email lists. Any Market Participants that are responsible for or have an interest in their companies' settlements are encouraged to subscribe to these email distribution lists. Market Participants may subscribe to these lists by contacting the NYISO Stakeholder Services Group. The NYISO maintains a schedule of meter data deadlines and challenge periods on its website:

<https://www.nyiso.com/billings-and-settlements>

3.3.1. Submission of Settlement and Invoice Challenges

To challenge settlement information contained in an invoice, a Customer must first make payment in full, including any amounts in dispute. Customer challenges to settlement information must:

- be submitted in writing, through the NYISO's Stakeholder Services group;
- be clearly identified as a settlement challenge;
- state the basis for the Customer's challenge, and
- include supporting documentation, where applicable.

The NYISO notifies all Customers of errors identified and the details of corrections or adjustments made as a result of challenges. The NYISO maintains a report on its Website listing each settlement

challenge, the effects of any warranted corrective measures, the quantification of the monetary impacts of such corrections by market sector and settlement type, and a status of the challenge's resolution. The report is reviewed during each Billing, Accounting, and Credit Policy Working Group meeting and is posted with the meeting materials at:

<https://www.nyiso.com/bacwg>

3.3.2. Transmission Interconnection, Generator, and Sub-Zone Load Metering Data Management and Challenges after Invoicing

The NYISO OATT Sections 2.7.4.2.1 and 2.7.4.2.2 and Services Tariff Sections 7.4.1.1 and 7.4.1.2 detail the time periods during which hourly billing quality meter data may be revised and challenged. The NYISO manages the metering data submission process and provides periodic notifications on an at least weekly basis to the marketplace to provide reasonable assurance that Market Participants are aware of the periods during which metering data may be challenged and revised, after which further revision may be accommodated only through an order of the FERC or court of competent jurisdiction.

3.3.2.1. Responsibility for Metering Data Accuracy

The TOs are charged with maintaining revenue quality metering systems for transmission line interconnections, Generators, and LSEs within their respective transmission districts, and the timely reporting of this data to the NYISO. It is the expectation of the NYISO that the TOs maintain reasonable and appropriate process controls over the accuracy and completeness of this data and the associated metering systems.

The NYISO administers the processes through which metering data is submitted by the TOs and performs certain substantive testing to assist the TOs in identifying potential erroneous or missing data. The NYISO coordinates the timely reconciliation and correction of such erroneous or missing data with the TOs. In the event that a Market Participant is unable to resolve a data challenge with the respective TO, the Market Participant should inform the NYISO of the dispute. The NYISO will consult with the reporting Market Participant and the responsible TO to determine what data is available. In the event that the NYISO is unable to facilitate a resolution to the Market Participant's challenge with the TO, the NYISO will determine the best data to be used in the settlement.

3.3.2.2. Revisions and Challenges to Transmission Interconnection, Generator, and Sub-Zone Load Metering Data after Invoicing

Submission of challenges to transmission interconnection, Generator, and sub-zone Load hourly meter data are limited to the 55-day period immediately following the issuance of a month's initial monthly invoice, and data updates are precluded beyond day-60. The NYISO manages the metering data submission

process and notifies the marketplace on an at least weekly basis to inform Market Participants of the defined time period during which they may challenge and provide for the revision of transmission interconnection, Generator, and sub-zone Load hourly metering data.

With the NYISO's issuance of a service month's initial monthly invoice, the associated email notification of the invoice posting includes verbiage announcing the beginning of the month's 55-day review and correction period for transmission interconnection, Generator, and sub-zone Load hourly metering data. The NYISO maintains a schedule of meter data deadlines and challenge periods on its website:

<https://www.nyiso.com/billings-and-settlements>

The schedule details the critical dates for each service month's metering data submissions, challenges, revisions, and preclusion from further challenge and revision.

The metering database remains locked until the end-of-business on the fifth business day after the issuance of the initial monthly invoice. As a result, data may not be updated during this period, except as needed to adjustment metering data for transmission interconnections with neighboring Control Areas to accommodate the reconciliation of interchange schedules to actual interchange flows through the NERC-required inadvertent interchange accounting and reporting process.

The NYISO must conclude its monthly inadvertent interchange analyses and desired net interchange (DNI) check-outs with its neighboring Control Areas (PJM, ISO-NE, IESO, and HQ) prior to the 16th of the month following the service month. In the event that inadvertent interchange analyses identify the need to revise transmission interconnection metering data, the NYISO coordinates such revisions with the affected TOs. Once any data revisions are completed, the database is relocked until the end-of-business on the fifth business day after the issuance of the initial monthly invoice.

At the end-of-business on the fifth business day after the issuance of the initial monthly invoice, the NYISO unlocks the metering database and sends an email informing the marketplace that the database has been unlocked and is available to receive transmission interconnection and Generator metering data updates. This email also serves as a notice to Suppliers to monitor their respective Generators' metering data for updates and to counter-party TOs to monitor the updates submitted by the TO - Meter Authorities for common transmission interconnections.

The metering database remains unlocked for a period of approximately thirty days, except for external Control Area transmission interconnections, to permit TOs an opportunity to submit updates. At the close of this period, the database is locked down, precluding further revisions by the TOs. At this point in time, transmission interconnection and Generator hourly meter data are subject to further revision only upon

written/emailed requests to the NYISO's Settlements Operations group at TSA@NYISO.com . The intent of this lock-down is to afford the counter-party TOs and Generators an opportunity to analyze the newly submitted data without the data being updated while performing such analyses.

As soon as practicable after the database has been locked down, the NYISO performs analyses to assist in the detection of potential data errors that may have been introduced into the database. Observed anomalies will be reported to the respective TOs for their review, reconciliation, or confirmation of their accuracy. In the event that errors are discovered after such lockdown, but within the 55-day period after the issuance of the month's initial monthly invoice, the NYISO coordinates the correction of such errors with the affected TOs and Suppliers.

In addition to the weekly marketplace notifications referenced above, the NYISO sends an email approximately two business-days prior to day-55 after the issuance of a service month's initial monthly invoice, reminding TOs and Suppliers of the impending lock-down date at which time transmission interconnection, Generator, and sub-zone Load meter data will no longer be subject to challenge. Generator, tie line, and sub-zone load metering data are no longer subject to revision at the close of business on day-60, absent an order by the FERC or court of competent jurisdiction.

3.3.3. LSE Metering Data Management and Challenges after Invoicing

The NYISO OATT Sections 2.7.4.2.1 and 2.7.4.2.2 and Services Tariff Sections 7.4.1.1 and 7.4.1.2 detail the time periods during which hourly billing quality meter data may be revised and challenged. The NYISO manages the metering data submission process and provides periodic notifications on an at least weekly basis to the marketplace to provide reasonable assurance that Market Participants are aware of the periods during which metering data may be challenged and revised, after which further revision may be accommodated only through an order of the FERC or court of competent jurisdiction.

3.3.3.1. Responsibility for Metering Data Accuracy

The TOs are charged with maintaining revenue quality metering systems for LSEs within their respective transmission districts and the timely reporting of hourly, revenue quality data to the NYISO. It is the expectation of the NYISO that the TOs administer this data in accordance with their respective retail access tariffs and maintain reasonable and appropriate process controls over the accuracy and completeness of this data and the associated metering systems.

The NYISO administers the processes through which LSE metering data is submitted by the TOs. In the event that a Market Participant is unable to resolve a data challenge with the respective TO, the Market Participant should inform the NYISO of the dispute. The NYISO will consult with the reporting Market

Participant and the responsible TO to facilitate timely resolution. In the event that the NYISO is unable to facilitate a resolution to the Market Participant's challenge with the TO, the NYISO will determine the best data to be used in the settlement.

3.3.3.2. Revisions and Challenges to LSE Metering Data

LSE hourly metering data accuracy may be challenged only through the 145-day period after the issuance of a service month's initial monthly invoice and are precluded from further revision 150 days following a service month's initial monthly invoice. LSE hourly metering data may be revised after the 150-day period following a service month's initial monthly invoice only through an order from the FERC or a court of competent jurisdiction.

The NYISO maintains marketplace awareness of the review and correction timeframes for LSE hourly metering data through periodic notices sent to the Billing, Accounting, and Credit Policy Working Group and Billing and Customer Settlements email lists.

On the first business-day of each week thereafter until the cutoff for LSE hourly meter data revisions 150 days following the initial monthly invoice, an email is informing the marketplace of the respective service months' review and correction periods for LSE hourly metering data.

In addition to the weekly notices, the NYISO emails a reminder notice approximately two business days prior to the day-70 due date of the impending due date. Upon receipt of all LSE data, the NYISO locks down the SDX database, preventing further data submissions without their being administered by NYISO Staff.

The NYISO accepts further updates to LSE meter data from the TOs up to the end of business on day-90 after the issuance of the service month's initial monthly invoice. The NYISO must process and post settlement results for the service month by close-of-business on day-89 after the issuance of a service month's initial monthly invoice. Requests to further update LSE meter data must be submitted in writing to NYISO's Settlement Operations group at: TSA@NYISO.com

In the event that meter data revisions are made during this review and correction period, the NYISO re-processes and re-posts updated settlement results and metering data to reflect such meter revisions, and provides appropriate market notices as previously detailed.

Four business days before the issuance of a service month's four-month true-up invoice, the NYISO temporarily suspends the acceptance of revisions to LSE hourly meter data in order to process and post the four-month true-up invoice.

The first business day after the issuance of the service month's four-month true-up, the NYISO will coordinate requests to unlock the SDX database for the submission of updated LSE meter data by the TOs.

Final LSE hourly metering data is due from TOs by day-130 after issuance of the service month's initial monthly invoice. Approximately four business days prior to the day-130 requirement for receiving revisions from the Transmission Owners, the NYISO sends an email reminding TOs and LSEs of the impending due date.

The NYISO posts updated settlement results, inclusive of all metering data updates, by day-135 after issuance of a service month's initial monthly invoice.

The NYISO sends an email approximately four business-days prior to day-145 after the issuance of a service month's initial monthly invoice, to remind MPs of the date when LSE meter data is no longer eligible for challenge. By day-150 after the issuance of a service month's initial monthly invoice, the NYISO re-processes and re-posts the month's settlements, inclusive of all final meter data. LSE metering data may be revised beyond the 150-day sunset provision only through an order of the FERC or court of competent jurisdiction.

3.4. Settlement and Invoice Disputes

3.4.1. Expedited Dispute Resolution Procedures for Unresolved Settlement Challenges

3.4.1.1. Applicability of Expedited Dispute Resolution Procedures

This section describes expedited dispute resolution procedures to address any dispute between a Customer and the NYISO regarding a Customer settlement that was not resolved in the ordinary settlement review, challenge, and correction process. Nothing herein restricts a Customer or the NYISO from seeking redress from the FERC in accordance with the Federal Power Act.

A Customer may request expedited dispute resolution if the Customer has previously presented a settlement challenge and has received from the NYISO a final, written determination regarding the settlement challenge. The scope of an expedited dispute resolution proceeding is limited to the subject matter of the Customer's prior settlement challenge.

Customer challenges regarding Generator, sub-zonal transmission tie-line interconnection, and LSE bus metering data are not eligible for formal dispute resolution proceedings under the NYISO Tariff. To ensure consistent treatment of disputes, separate requests for expedited dispute resolution regarding the same issue and the same service month or months may be resolved on a consolidated basis, consistent with applicable confidentiality requirements.

3.4.1.2. Initiation of Expedited Dispute Resolution Proceedings

To initiate an expedited dispute resolution proceeding, a Customer must submit a written request to

the NYISO Chief Financial Officer within eleven (11) business days from the date that the NYISO issues a final, written determination regarding a Customer settlement challenge. A Customer's written request for expedited dispute resolution must contain: (i) the name of the Customer making the request, (ii) an indication of other potentially affected parties, to the extent known, (iii) an estimate of the amount in controversy, (iv) a description of the Customer's claim with sufficient detail to enable the NYISO to determine whether the claim is within the subject matter of a settlement challenge previously submitted by the Customer, (v) copies of the settlement challenge materials previously submitted by the Customer to the NYISO, and (vi) citations to the NYISO Tariffs and other relevant materials on which the Customer's settlement challenge relies.

The NYISO Chief Financial Officer will acknowledge in writing receipt of the Customer's request to initiate an expedited dispute resolution proceeding. If the NYISO determines that the proceeding would be likely to aid in the resolution of the dispute, the NYISO will accept the Customer's request and provide written notice of the proceeding to all Customers through the ordinary means of communication for settlement issues. The NYISO will provide written notice to the Customer in the event that the NYISO declines its request for expedited dispute resolution.

3.4.1.3. Participation by Other Interested Customers

Any Customer with rights or interests that would be materially affected by the outcome of an expedited dispute resolution proceeding may participate, providing, however, that a Customer seeking or supporting a change to the NYISO's determination regarding a Customer settlement challenge previously raised the issue in a settlement challenge. To participate, a Customer must submit to the NYISO Chief Financial Officer, within eleven (11) business days from the date that the NYISO issues notice of the expedited dispute resolution proceeding, a written participation request that meets the requirements for an initiating request for expedited dispute resolution. If the NYISO determines that the Customer has met the requirements of this section, the NYISO will accept the Customer's request to participate in the dispute resolution proceeding.

3.4.1.4. Selection of a Neutral

As soon as reasonably possible following the NYISO's acceptance of a Customer's request for expedited dispute resolution, the NYISO will appoint a neutral to preside over the proceeding by randomly selecting from a list (i) provided to the NYISO by the American Arbitration Association or (ii) developed by the NYISO with input from the appropriate stakeholder committee, until an available neutral is found. To the extent possible, the neutral will be knowledgeable in electric utility matters, including electric transmission and bulk power issues and the financial settlement of electric markets.

No person will be eligible to act as a neutral who is a past or present officer, employee, or consultant to any of the disputing parties, or of an entity related to or affiliated with any of the disputing parties, or is otherwise interested in the matter in dispute except upon the express written consent of the parties. Any individual appointed as a neutral will make known to the disputing parties any such disqualifying relationship or interest, and a new neutral will be appointed, unless express written consent is provided by each party.

3.4.1.5. Conduct of the Expedited Dispute Resolution Proceeding

The neutral schedules the initial meeting of the disputing parties within five (5) business days of appointment. Except as otherwise provided by the NYISO Tariff, the neutral has discretion over the conduct of the dispute resolution process including but not limited to: (i) requiring the disputing parties to meet for discussion, (ii) allowing or requiring written submissions, (iii) establishing guidelines for such written submissions, and (iv) allowing the participation of Customers that have requested an opportunity to be heard.

Within sixty (60) days of the appointment of the neutral, if the dispute has not been resolved, the neutral will provide the disputing parties with a written, confidential, and nonbinding recommendation for resolving the dispute. The disputing parties will then meet in an attempt to resolve the dispute in light of the neutral's recommendation. If the disputing parties have not resolved the dispute within ten (10) days of receipt of the neutral's recommendation, the dispute resolution process will be concluded. Neither the recommendation of the neutral, nor statements made by the neutral or any party, including the NYISO, or their representatives, nor written submissions prepared for the dispute resolution process, will be admissible for any purpose in any proceeding.

3.4.1.6. Allocation of Costs

Each party to a dispute resolution proceeding is responsible for its own costs incurred during the expedited dispute resolution process and for a pro rata share of the costs of the neutral.

3.5. Customer Default

3.5.1. Default Event

An event of default ("Default") occurs when a Customer (the "Defaulting Party"):

- fails to comply with the NYISO's creditworthiness requirements and receive notice of such failure;
- fails to comply with NYISO Tariff provisions for eligibility to obtain services in response to sales tax issues;

- makes an assignment or any general arrangement for the benefit of creditors;
- fails to timely make a payment due to the NYISO, regardless of whether such payment is in dispute, and receives notice from the NYISO of such failure;
- fails to cure its default in another independent system operator/regional transmission organization market;
- files a petition or otherwise commences, authorizes, or acquiesces in the commencement of a case, petition, proceeding, or cause of action under any bankruptcy or insolvency law or similar law for the protection of debtors or creditors, or have such a petition, case, proceeding, or cause of action filed or commenced against it and such case, petition, proceeding, or cause of action is not withdrawn or dismissed within thirty (30) days after such filing or commencement;
- otherwise becomes bankrupt or insolvent (however evidenced);
- becomes unable or unwilling to pay its third-party debts as they fall due;
- otherwise becomes adjudicated a debtor in bankruptcy or insolvent (however evidenced);
- becomes unable (or admits in writing its inability) generally to pay its debts as they become due;
- becomes dissolved (other than pursuant to a consolidation, acquisition, amalgamation, or merger);
- has a resolution passed for its winding up official management or liquidation (other than pursuant to a consolidation, acquisition, amalgamation, or merger);
- seeks or becomes subject to the appointment of an administrator, provisional liquidator, conservator, assignee, receiver, trustee, custodian, or other similar entity or official for all or substantially all of its assets;
- has a secured party take possession of all or substantially all of its assets or has a distress, levy, execution, attachment, sequestration, or other legal process levied, enforced, or sued on or against all or substantially all of its assets and such secured party maintains possession, or any such process is not dismissed, discharged, stayed, or restrained, in each case within thirty (30) days thereafter;
- causes or is subject to any event with respect to which, under the applicable laws of any jurisdiction, said event has an analogous effect to any of the events specified above;
- takes any action in furtherance of, or indicating its consent to, approval of, or acquiescence in, any of the foregoing acts; or
- fails to perform any material covenant set forth in the Tariff or a Service Agreement (other than the events that are otherwise specifically covered in this Section as a separate Event of Default), and such failure is not excused by Force Majeure or cured within five (5) business days after written notice thereof to the Defaulting Party.

3.5.2. Cure of Default

The NYISO has the right to apply any amounts owed a Customer against any amounts owed to the NYISO by a Customer. A Customer has two (2) business days to cure a Default resulting from its failure to timely make a payment due to the NYISO. A Customer will have three (3) business days to cure a Default resulting from the Customer's failure to comply with the NYISO's creditworthiness requirements; provided, however, that a Customer will have one (1) business day to cure a default resulting from its failure to

comply with the NYISO's creditworthiness requirements following termination of a Prepayment Agreement. Further, by entering into Transactions under the NYISO Tariff, Customers' Service Agreements and Transactions constitute "forward contracts" within the meaning of the United States Bankruptcy Code.

3.5.3. The NYISO's Right to Suspend and/or Terminate Service

Upon an event of Default and expiration of any cure period, the NYISO has the right to suspend and/or terminate the Service Agreement immediately upon notice to the Commission in addition to any and all other remedies available hereunder or pursuant to law or in equity.

4. Energy Supplier Settlements

4.1. Energy Supplier Settlement – Generators

4.1.1. DAM Energy Supplier Settlement – Generators

Each Supplier that is scheduled by the NYISO to sell Energy in the DAM is paid the product of: (a) the Generator's Day-Ahead hourly LBMP and (b) the Generator's hourly Energy schedule, exclusive of any Energy scheduled day-ahead to support Bilateral Transactions. The calculation of the DAM Energy Supplier settlement for Generators is represented formulaically in Appendix B.

4.1.2. DAM Bid Production Cost Guarantee (BPCG) - Generators

The NYISO will determine if a Supplier eligible pursuant to Section 4.1.2.1 below for a Day-Ahead Bid Production Cost Guarantee payment will not recover its Day-Ahead Regulation Capacity Bid, Operating Reserves Bid, or its Minimum Generation Bid, Start-Up Bid, and Incremental Energy Bid to produce Energy in the Day-Ahead Market (including Energy provided by the Capacity scheduled for Regulation Service) through Day-Ahead revenue. Day-Ahead revenue includes Day-Ahead LBMP revenue, Day-Ahead Imputed LBMP Revenue and net Day-Ahead Ancillary Services revenues for Voltage Support Service, Regulation Service, and synchronized Operating Reserves. Such determination will be made for an entire Day-Ahead Market day, and such determination will be made separately for each Generator. On the basis of such determination (and subject to any mitigation that may apply) the NYISO will pay a Day-Ahead BPCG to the Supplier pursuant to the algorithm in Appendix E of this manual.

4.1.2.1. DAM BPCG Eligibility

A Supplier that bids on behalf of an ISO-Committed Fixed Generator or an ISO-Committed Flexible Generator or an ISO-Committed Flexible Aggregation that is committed by the NYISO in the Day-Ahead Market (DAM) will be eligible to receive a DAM BPCG payment as long as that Generator has not been committed in the Day-Ahead Market for any other hour of the day as a result of a Self-Committed Fixed or Self-Committed Flexible Bid. Energy Storage Resources and Aggregations comprised entirely of Energy Storage Resources that satisfy this eligibility criteria shall be eligible to receive a Day-Ahead Bid Production Cost guarantee payment regardless of whether the Resource Self-Manages its Energy Level.

4.1.2.2. Formulas for Determining DAM BPCG for Generators

The formula for determining the DAM BPCG paid to a Supplier is illustrated in Appendix E of this manual.

4.1.2.2.1. Proration of Start-Up Bid for Generators that are Committed in the Day-Ahead Market, or via Supplemental Resource Evaluation

4.1.2.2.1.1. *Eligibility to Recover Operating Costs and Resulting Obligations*

Generators committed in the Day-Ahead Market or via Supplemental Resource Evaluation (SRE) that are not able to complete their minimum run time within the Dispatch Day in which they are committed are eligible to include in their Start-Up Bid expected net costs of operating on the day following the Dispatch Day at the minimum operating level specified for the hour in which the Generator is committed, for the hours necessary to complete the Generator's minimum run time.

Generators that receive Day-Ahead or SRE schedules that are not scheduled to operate in real-time, or that do not operate in real-time, at the MW level included in the Minimum Generation Bid for the first hour of the Generator's Day-Ahead or SRE schedule, for the longer of (a) the duration of the Generator's Day-Ahead or SRE schedule or (b) the minimum run time specified in the Bid that was accepted for the first hour of the Generator's Day-Ahead or SRE schedule, will have the start-up cost component of the Bid Production Cost Guarantee calculation prorated in accordance with the formula illustrated in Appendix E. The rules for prorating the start-up cost component of the Bid Production Cost Guarantee calculation apply both to the operation within the Dispatch Day and to operation on the day following the Dispatch Day to satisfy the minimum run time specified for the hour in which the Generator was scheduled to start-up on the Dispatch Day.

Rules for calculating the reference level that the NYISO uses to test Start-Up Bids for possible mitigation are included in the Market Power Mitigation Measures that are set forth in Attachment H to the NYISO Services Tariff. Proration of the start-up cost component of a Generator's Bid Production Cost Guarantee based on the Generator's operation in real-time is different and distinct from the mitigation of a Start-Up Bid.

4.1.2.3. Proration of Eligible Start-Up Cost when a Generator is Not Scheduled, or Does Not Operate to Meet the Schedule Specified in the Accepted Day-Ahead Start-Up Bid

The start-up costs included in the Bid Production Cost Guarantee calculation may be reduced pro rata based on a comparison of the actual MWs delivered in real-time to an hourly minimum MW requirement. The hourly MWh requirement is determined based on the MW component of the Minimum Generation Bid submitted for the Generator's accepted start hour (as mitigated, where appropriate). The proration calculation is illustrated in Appendix E.

4.1.2.4. Day-Ahead BPCG for Demand Side Resources Scheduled to Provide Synchronized Operating Reserves and/or Regulation Service

The NYISO will determine if a Supplier that bids Demand Side Resources committed by the NYISO to

provide synchronized Operating Reserves and/or Regulation Service in the Day-Ahead Market will not recover its Day-Ahead synchronized Operating Reserves Bid to provide the amount of synchronized Operating Reserves that it was scheduled to provide, and/or its Day-Ahead Regulation Capacity Bid to provide the amount of Regulation Capacity that it was scheduled to provide. Such supplier will be eligible under Section 4.1.2.3.1 of this manual for a Day-Ahead Bid Production Cost Guarantee payment. Such determination will be made for an entire Day-Ahead Market day, and such determination will be made separately for each Demand Side Resource. On the basis of such determination, the NYISO will make a Bid Production Cost Guarantee payment to the Customer pursuant to this Section 4.1.2.3.

4.1.2.4.1. Eligibility for BPCG for Demand Side Resources Providing Synchronized Operating Reserves and/or Regulation Service in the Day-Ahead Market

Any Supplier that bids a Demand Side Resource that is committed by the NYISO to provide synchronized Operating Reserves and/or Regulation Service in the Day-Ahead Market will be eligible to receive a Bid Production Cost Guarantee payment under this Section 4.1.2.3.

4.1.2.4.2. Formula for Determining BPCG for Demand Side Resources Providing Synchronized Operating Reserves and/or Regulation Service in the Day-Ahead Market

The formula for determining BPCG for Demand Side Resources providing Synchronized Operating Reserves and/or Regulation Service is detailed in Appendix E of this manual.

4.1.3. Balancing Market Energy Supplier Settlement – Generators

4.1.3.1. Basis for Energy Settlements

Balancing Market Energy settlements are performed for each Real-Time Dispatch (RTD) interval, which are nominally five minutes in length and are based upon a Generator's measured performance, relative to its scheduled operation (inclusive of Energy scheduled to support Bilateral Transactions) and Bid parameters. The calculation of the Balancing Market Energy Supplier settlement for Generators is represented formulaically in Appendix B.

4.1.3.2. Adjustment of Actual Energy Injections and Actual Energy Withdrawals and Actual Demand Reductions to Revenue Quality Metered Values

Balancing Market Energy settlements are performed for each Real-Time Dispatch (RTD) interval, which are nominally five minutes in length. Generators' Actual Energy Injections, Actual Energy Withdrawals, and Actual Demand Reductions (in the case of DER Aggregations) are measured in real-time and transmitted to the NYISO typically in six (6) second scans by the NYISO's Energy Management System (EMS). The data obtained through the EMS' six-second scans are compiled into dispatch interval performance metrics by the NYISO's performance tracking application. Appendix G details the computation of dispatch interval

performance data.

The metering systems which measure Generators' instantaneous Energy injections and withdrawals are not typically comprised of revenue grade metering components and the sampling process through which this information is transmitted to the NYISO does not provide a revenue quality billing determinant; therefore, the values transmitted to the NYISO in real-time are subsequently adjusted to revenue quality values with data from revenue grade metering systems.

The day after the service day, the NYISO computes Generators' actual RTD interval Energy injections by averaging Generators' six-second instantaneous outputs over each RTD interval. By the first business day after the service day, hourly revenue quality metering data is submitted by the Meter Authority. Each RTD interval Energy injection value is adjusted by multiplying each RTD interval Energy injection value by the ratio of the (i) Generators' hourly revenue quality metered injection and (ii) the hourly integration of the Generators' RTD interval Actual Energy Injections over the hour.

For withdrawals by Withdrawal Eligible Generators the NYISO will also calculate the Generators' actual RTD interval Energy withdrawals by averaging Generators' six-second instantaneous outputs over each RTD interval. Each RTD interval Energy withdrawal value is adjusted by multiplying each RTD interval Energy withdrawal value by the ratio of the (i) Generators' hourly revenue quality metered withdrawal and (ii) the hourly integration of the Generators' RTD interval Actual Energy withdrawal over the hour. The sum of the adjusted Energy injection and withdrawal values is the megawatt output for the Withdrawal Eligible Generator used in the balancing energy settlement calculation.

For DER Aggregations with demand reduction capability, the NYISO will calculate the Aggregation's actual RTD interval demand reductions by averaging the six-second instantaneous demand reductions over each RTD interval. Each RTD interval demand reduction value is adjusted by multiplying the RTD interval demand reduction value by the ratio of (i) the DER Aggregation's hourly reported demand reduction to (ii) the hourly integration of the DER Aggregation's RTD interval actual demand reduction over the hour. The sum of the adjusted injection, withdrawal, and demand reduction values is the megawatt output for DER Aggregation used in the balancing energy settlement calculation.

4.1.3.3. Compensable Overgeneration

Compensable Overgeneration is a quantity of Energy provided over a given RTD interval that exceeds the Real-Time Scheduled Energy established by the NYISO for that Generator and for which the Supplier bidding that Generator may be paid pursuant to this section and the procedures detailed in Appendix B.

For Generators not covered by other provisions of this section and Intermittent Power Resources depending on wind or solar as their fuel for which the NYISO has imposed a Wind and Solar Output Limit in the given RTD interval, Compensable Overgeneration will initially equal 3% of the Generator's Normal Upper Operating Limit which may be modified by the NYISO if necessary to maintain good Control Performance.

For a Generator or Aggregation:

- (i) which is operating in Start-Up or Shutdown Periods, or Testing Periods; or
- (ii) which is a Limited Control Run of River Hydro Resource that has offered its Energy to the ISO in a given interval not using the ISO-committed Flexible or Self-Committed Flexible bid mode; or
- (iii) which is an Intermittent Power Resource that depends on landfill gas for its fuel and has offered its Energy to the ISO in a given interval not using the ISO-committed Flexible or Self-Committed Flexible bid mode; or
- (iv) which is an Intermittent Power Resource that depends on wind or solar energy for its fuel,

Compensable Overgeneration shall mean all Energy actually provided by the Generator or Aggregation that exceeds the Real-Time Scheduled Energy Injection established by the ISO for that Generator or Aggregation; provided however, this definition of Compensable Overgeneration shall not apply to an Intermittent Power Resource depending on wind or solar energy as its fuel for any interval for which the ISO has imposed a Wind and Solar Output Limit.

For a Generator or Aggregation operating in intervals when it has been designated as operating Out of Merit at the request of a Transmission Owner or the ISO, Compensable Overgeneration shall mean all Energy actually provided by the Generator or Aggregation that exceeds the Real-Time Scheduled Energy Injection up to the Energy level directed by the Transmission Owner or the ISO.

For a Generator comprised of a group of generating units at a single location, which grouped generating units are separately committed and dispatched by the ISO, and for which Energy injections are measured at a single location, Compensable Overgeneration shall mean that quantity of Energy provided by the Generator, during the period when one of its grouped generating units is operating in a Start-Up or Shutdown Period, that exceeds the Real-Time Scheduled Energy established by the ISO for that period, for that Generator, and for which the Generator may be paid pursuant to the procedures described in Appendix B.

4.1.3.4. Settlement Eligibility for Demand Reductions

A DER Aggregation may offer into the Day-Ahead Market or Real-Time Market below the Monthly Net Benefit Threshold. However, when a DER Aggregation receives a real-time Energy schedule, and the Real-Time LBMP calculated in that RTD interval for the applicable Transmission Node is less than the Monthly Net Benefit Threshold price, Demand Reductions by the DER Aggregation may not be eligible for Energy payments. The eligibility for energy payments for Demand Reductions and the interaction of Demand Reductions with the level of compensable generation is further described in the Balancing Market Energy Supplier settlement for Generators represented formulaically in Appendix B.

4.1.4. Real-Time Bid Production Cost Guarantee for Generators in RTD Intervals Other than Supplemental Event Intervals

The NYISO will determine if a Supplier eligible pursuant to Section 4.1.4.1 below for a Real-Time Bid Production Cost Guarantee payment will not recover its Real-Time Regulation Capacity Bid, Regulation Movement Bid, Operating Reserves Bid, or its Minimum Generation Bid, Start-Up Bid, and Incremental Energy Bid to produce Energy that was not scheduled in the Day-Ahead Market, including Energy provided by the Capacity scheduled for Regulation Service, through Real-Time LBMP revenue, Real-Time Imputed LBMP Revenue and net Real-Time Ancillary Services revenues for Voltage Support Service, Regulation Service, and synchronized Operating Reserves. Such determination will be made for an entire Dispatch Day (except for Supplemental Event Intervals). Such determination will be made separately for each Generator. On the basis of such determination, and subject to any mitigation that may apply, the NYISO will pay a Real-Time Bid Production Cost Guarantee payment to the Supplier pursuant to the algorithm in Appendix E of this manual.

An Energy Storage Resource with an ISO-Managed Energy Level for any hour of the Real-Time Market day shall not be eligible to receive a real-time Bid Production Cost guarantee payment for that day, provided however, an Energy Storage Resource shall be eligible for a real-time Bid Production Cost guarantee payment in accordance with Section 18.4.1.1.3 of the Services Tariff regardless of whether the Energy Level is ISO-Managed.

4.1.4.1. Eligibility for Receiving Real-Time BPCG for Generators and Aggregations in RTD Intervals Other Than Supplemental Event intervals

A Supplier will be eligible to receive a Real-Time Bid Production Cost Guarantee payment for intervals (excluding Supplemental Event Intervals) if it bids on behalf of (a) an ISO-Committed Flexible Generator or an ISO-Committed Fixed Generator (other than an Aggregation) that is committed by the NYISO in the Real-Time Market; (b) a Self-Committed Flexible Generator (other than an Aggregation) if the Generator's

minimum generation MW level does not exceed its Day-Ahead schedule at any point during the Dispatch Day; or (c) a Generator or Aggregation committed via SRE, or committed or dispatched by the NYISO as Out-of-Merit generation to ensure NYCA or local system reliability for the hours of the day that it is committed via SRE or is committed or dispatched by the NYISO as Out-of-Merit generation to meet NYCA or local system reliability without regard to the Bid mode(s) employed during the Dispatch Day or an ISO - Committed Flexible Aggregation comprised entirely of Energy Storage Resources that Self-Manages its Energy Level. Suppliers bidding on behalf of Resources that were not committed by the NYISO to operate in a given Dispatch Day, but which continue to operate due to minimum run time Constraints, will not receive such a supplemental payment.

A Supplier that bids on behalf of an ISO-Committed Fixed Generator or an ISO-Committed Fixed Aggregation or an ISO-Committed Flexible Generator that is committed by the NYISO in the Real-Time Market will not be eligible to receive a Real-Time Bid Production Cost Guarantee payment if that Generator or Aggregation has been committed in Real-Time, in any other hour of the day, as the result of a Self-Committed Fixed Bid, or a Self-Committed Flexible Bid with a minimum operating level that exceeds its Day-Ahead schedule, *provided however*, a Generator or Aggregation that has been committed in real time as a result of a Self-Committed Fixed Bid, or a Self-Committed Flexible Bid with a minimum operating level that exceeds its Day-Ahead schedule will not be precluded from receiving a Real-Time Bid Production Cost Guarantee payment for other hours of the Dispatch Day, in which it is otherwise eligible, due to these Self-Committed mode Bids if such Bid mode was used for: (i) a NYISO authorized Start-Up, Shutdown or Testing Period, or (ii) for hours in which such Generator or Aggregation was committed via SRE or committed or dispatched by the NYISO as Out-of-Merit to meet NYCA or local system reliability as long as the Generator's Out-of-Merit Upper Operating Limit is equal to or greater than any Self-Committed minimum operating level..

4.1.4.2. Formula for Determining Real-Time BPCG for Generators in RTD Intervals Other Than Supplemental Event Intervals

The formula for determining Real-Time BPCG for Generators in RTD intervals other than supplemental event intervals is detailed in Appendix E of this manual.

4.1.4.2.1. Proration of Start-Up Bid for Generators that are Committed in the Day-Ahead Market, or Via Supplemental Resource Evaluation

4.1.4.2.1.1. Eligibility to Recover Operating Costs and Resulting Obligations

Refer to Section 4.1.2.2.1.1 for a description of the eligibility requirements.

4.1.4.2.1.2. Proration of Eligible Start-Up Cost when a Generator is Not Scheduled, or Does Not Operate to Meet the Schedule Specified in the Accepted Day-Ahead or SRE Start-Up Bid

Refer to Section 4.1.2.2.1.2 for a description of the proration requirements.

4.1.4.2.2. Start Up Payments for Generators Scheduled to Start in Real Time by RTC or RTD

An ISO-Committed flexible unit, with both a Day-Ahead and a Real-Time schedule, may be eligible for two guaranteed start-up payments, each calculated separately. A Generator with a Day-Ahead schedule that has bid into the RT Market may be scheduled by the NYISO, if economic, by the Real-Time Commitment (RTC) software to start in hours other than those hours scheduled Day-Ahead. A Generator scheduled by RTC to start up outside of its DAM schedule also will be eligible for the start up costs submitted in the Real-Time Market for that unit. The unit must run within the scheduled hour to have its start-up cost included in the cost recovery calculation

ISO-Committed fixed units that have a Day-Ahead schedule and operate as self-committed fixed units in the Real-Time Market receive only Day-Ahead start-up guarantees.

4.1.4.2.3. 10minute Start-Up time Generators

A Generator with a 10-minutes start-up time that is economically committed by RTC or RTD must start (begin producing energy) within 20 minutes of the scheduled start time or its Real-Time Start-Up Bid will be set to \$0 for purposes of calculating its Real-Time BPCG.

4.1.4.2.3.1. All other Generators

All other Generators that are economically committed by RTC must start within 45 minutes of their scheduled start time or their Real-Time Start-Up Bids will be set to \$0 for purposes of calculating a Real-Time BPCG.

4.1.4.3. Real-Time BPCG for Demand Side Resources Providing Synchronized Operating Reserves and/or Regulation Service

The NYISO will determine if a Supplier that bids Demand Side Resources committed by the NYISO to provide synchronized Operating Reserves and/or Regulation Service will not recover its real-time synchronized Operating Reserves Bid to provide the amount of synchronized Operating Reserves that it was scheduled to provide, and/or its Real-Time Regulation Capacity and Movement Bids to provide Regulation Service. Such Supplier will be eligible under Section 4.1.4.3.1 of this manual for a Real-Time Bid Production Cost Guarantee payment. Such determination will be made for an entire Dispatch Day, and such determination will be made separately for each Demand Side Resource. On the basis of such determination, the NYISO will make a Bid Production Cost Guarantee payment to the Customer pursuant to the algorithm described in Appendix E of this manual.

4.1.4.3.1. Eligibility for BPCG for Demand Side Resources Providing Synchronized Operating Reserves and/or Regulation Service in the Real-Time Market

Any Supplier that bids a Demand Side Resource that is committed by the NYISO to provide synchronized Operating Reserves and/or Regulation Service in the Real-Time Market will be eligible to

receive a Bid Production Cost Guarantee payment under this Section 4.1.4.3.

4.1.4.3.2. Formula for Determining BPCG for Demand Side Resources Providing Synchronized Operating Reserves and/or Regulation Service in the Real-Time Market

The formula for determining BPCG for Demand Side Resources providing synchronized Operating Reserves and/or Regulation Service in the Real-Time Market is detailed in Appendix E of this manual.

4.1.5. BPCG for Generators for Supplemental Event Intervals

The NYISO will determine if a Supplier eligible pursuant to Section 4.1.5.1 below for a Bid Production Cost Guarantee payment for a Supplemental Event Interval will not recover its Real-Time Regulation Capacity Bid, Regulation Movement Bid, Operating Reserves Bid, or its Minimum Generation Bid and Incremental Energy Bid to produce Energy that was not scheduled Day-Ahead (including Energy provided by the Capacity scheduled for Regulation Service) through Real-Time revenue. Real-Time revenue includes Real-Time LBMP revenue, Real-Time Imputed LBMP Revenue and net Real-Time Ancillary Services revenues for Voltage Support Service, Regulation Service, and Operating Reserves in that interval. Such determination will be made separately for each Supplemental Event Interval, and such determination will be made separately for each Generator. On the basis of such determination, the NYISO will pay a Bid Production Cost Guarantee payment to the Supplier for a Supplemental Event Interval pursuant to the algorithm in Appendix E of this manual.

4.1.5.1. Eligibility for BPCG for Generators in Supplemental Event Intervals

For intervals in which the NYISO has called a large event reserve pick-up, as described in Section 4.4.3.1.1 of the NYISO Services Tariff, or an emergency, as described in Section 4.4.3.1.2 of the NYISO Services Tariff, any Supplier who meets the eligibility requirements for a Real-Time Bid Production Cost Guarantee payment described in Section 4.1.4.1 of this manual will be eligible to receive a BPCG under this Section 4.1.5.

A Supplier will be eligible to receive a Bid Production Cost Guarantee payment for a Generator producing energy during Supplemental Event Intervals occurring as a result of a NYISO emergency under Section 4.4.3.1.2 of the NYISO Services Tariff regardless of Bid mode used for the day.

Notwithstanding the above, a Supplier will not be eligible to receive a Bid Production Cost Guarantee payment for Supplemental Event Intervals if the Supplier is not eligible for a Real-Time Bid Production Cost Guarantee payment for the reasons described in Section 4.1.4 of this manual.

4.1.5.2. Real-Time BPCG for Generators in Supplemental Event Intervals

The formula for determining Real-Time BPCG for Generators in Supplemental Event Intervals is

detailed in Appendix E of this manual.

4.1.6. BPCG for Long Start-Up Time Generators Whose Starts Are Aborted by the NYISO Prior to their Dispatch

The NYISO will pay a Supplier eligible under Section 4.1.6.1 of this manual for a Bid Production Cost Guarantee payment for a long start-up time Generator (i.e., a Generator that cannot be scheduled by SCUC to start up in time for the next Dispatch Day) whose start is aborted by the NYISO prior to its dispatch for that portion of its Start-Up Bid that corresponds to that portion of its start-up sequence that it completed prior to being aborted. Such determination will be made for an entire Dispatch Day, and such determination will be made separately for each long start-up time Generator. On the basis of such determination, the NYISO will pay a Bid Production Cost Guarantee payment to the Supplier pursuant to the methodology described in Section 4.1.6.2 below.

4.1.6.1. Eligibility for BPCG for Long Start-Up Time Generators Whose Starts Are Aborted by the NYISO Prior to their Dispatch

A Supplier that bids on behalf of a long start-up time Generator (i.e., a Generator that cannot be scheduled by SCUC to start up in time for the next Dispatch Day) that is committed by the NYISO for reliability purposes as a result of a Supplemental Resource Evaluation and whose start is aborted by the NYISO prior to its dispatch, as described in Section 4.2.4 of the NYISO Services Tariff, will be eligible to receive a Bid Production Cost Guarantee payment under this Section 4.1.6.

4.1.6.2. Methodology for Determining BPCG for Long Start-Up Time Generators Whose Starts are Aborted by the NYISO Prior to their Dispatch

A Supplier whose long start-up time Generator's start-up is aborted will receive a prorated portion of its Start-Up Bid submitted for the hour in which the NYISO requested that the Generator begin its start-up sequence, based on the portion of the start-up sequence that it has completed prior to the signal to abort the start-up (e.g., if a long start-up time Generator with a seventy-two (72) hour start-up time has its start-up sequence aborted after forty-eight (48) hours, it would receive two-thirds (2/3) of its Start-Up Bid).

4.1.7. Day-Ahead Margin Assurance Payments (DAMAP)

If a Supplier that is eligible pursuant to Section 4.1.7.1 below buys out of a Day-Ahead Energy, Regulation Service, or Operating Reserve schedule in a manner that reduces its Day-Ahead Margin, it will receive a Day-Ahead Margin Assurance Payment (DAMAP), with the potential exceptions of Generators that lag behind their real-time Base Point Signals and Suppliers that have been derated. The purpose of such payments is to protect Suppliers' Day-Ahead Margins associated with real-time reductions after accounting for: (i) any real-time profits associated with offsetting increases in real-time Energy, Regulation Service, or

Operating Reserve Schedules; and (ii) any Supplier requested real-time derate granted by the NYISO.

4.1.7.1. DAMAP Eligibility

The following categories of Resources bid by Suppliers are eligible to receive DAMAP: (i) all Self-Committed Flexible and ISO-Committed Flexible Generators, other than Energy Storage Resources and Aggregations, that are either online and dispatched by RTD or available for commitment by RTC; (ii) Demand Side Resources committed to provide Operating Reserves or Regulation Service; (iii) any Resource, including an Energy Storage Resource or an Aggregation, that is scheduled out of economic merit order by the NYISO in response to a NYISO or Transmission Owner system security need or to permit the NYISO to procure additional Operating Reserves; (iv) any Resource, including an Energy Storage Resource or an Aggregation, internal to the NYCA that is derated or decommitted by the NYISO in response to a NYISO or Transmission Owner system security need or to permit the NYISO to procure additional Operating Reserves; (v) Energy Limited Resources or an Aggregation comprised entirely of Energy Limited Resources with a NYISO-approved real-time reduction in output from its Day-Ahead schedule and (vi) Limited Energy Storage Resources and Aggregations comprised entirely of Limited Energy Storage Resources scheduled to provide Regulation Service, as described in Section 25.3.2 of the ISO Services Tariff.

4.1.7.1.1. Exceptions to DAMAP Eligibility

Notwithstanding the above DAMAP eligibility criteria, no Day-Ahead Margin Assurance Payment shall be paid to:

- (i) a Resource, otherwise eligible for a DAMAP, in hours in which the NYISO has increased the Resource's minimum operating level above the Resource's Day-Ahead Market Energy schedule either, either: (i) at the Resource's request including through an adjustment to the Resource's self-commitment schedule;; or (ii) in order to reconcile the NYISO's dispatch with the Generator's actual output or to address reliability concerns that arise because the Generator is not following Base Point Signals; or (iii) an Intermittent Power Resource that depends on wind or solar energy as its fuel.
- (ii) a Resource, otherwise eligible for Day-Ahead Margin Assurance Payments, in hours in which the NYISO has increased the Resource's real-time minimum operating level at the Resource's request, including through an adjustment to the Resource's self-commitment schedule, above the MW level determined by subtracting the Resource's Day-Ahead Market Regulation Service schedule from its Day-Ahead Market Energy schedule.
- (iii) a Resource, otherwise eligible for Day-Ahead Margin Assurance Payments, in hours in which the

Resource reduces the MW quantity specified in its real-time Regulation Capacity Bid below its Day-Ahead Market Regulation Service schedule.

(iv) a Generator, otherwise eligible for a DAMAP, for: (i) any hour in which Incremental Energy Bids submitted in the Real-Time Market for that Generator exceed the Incremental Energy Bids submitted in the Day-Ahead Market, or the mitigated Day-Ahead Incremental Energy Bids, where appropriate, for the portion of that Generator's Capacity that was scheduled in the Day-Ahead Market; and (ii) the two hours immediately preceding and the two hours immediately following the hour(s) identified in (i).

(v) a Generator that is available for commitment by RTC and otherwise eligible for Day-Ahead Margin Assurance Payments, for (i) any hour in which the Start-Up Bids submitted in the real-time market for that Generator exceed the Start-Up Bids submitted in the Day-Ahead Market, or the mitigated Day-Ahead Start-Up Bids where appropriate, and that Generator was scheduled for Energy or Regulation Service in that hour in the Day-Ahead Market; and (ii) the two hours immediately preceding and the two hours immediately following the hour(s) in which the Start-Up Bids submitted in the real-time market for that Generator exceed the Start-Up Bids submitted in the Day-Ahead Market, or the mitigated Day-Ahead Start-Up Bids where appropriate, and that Generator was scheduled for Energy or Regulation Service in that hour in the Day-Ahead Market. If an otherwise eligible Generator's average Actual Energy Injection in an RTD interval (i.e., its Actual Energy Injections averaged over the RTD interval) is less than or equal to its penalty limit for under-generation value for that interval, the Generator is not eligible for DAMAP for that interval. The calculation of a Generator's penalty limit for undergeneration (PLU) is detailed in Appendix I of this manual.

(vi) a Generator that is available for commitment by RTC and otherwise eligible for Day-Ahead Margin Assurance Payments, for (i) any hour in which the dollar component of the Minimum Generation Bids submitted in the Real-Time Market for that Generator exceed the dollar component of the Minimum Generation Bids submitted in the Day-Ahead Market, or the dollar component of the mitigated Day-Ahead Minimum Generation Bids where appropriate, and that Generator was scheduled for Energy in that hour in the Day-Ahead Market; and (ii) the two hours immediately preceding and the two hours immediately following the hour(s) in which the dollar component of the Minimum Generation Bids submitted in the Real-Time Market for that Generator exceed the dollar component of the Minimum Generation Bids submitted in the Day-Ahead Market, or the dollar component of the mitigated Day-Ahead Minimum Generation Bids where appropriate, and

that Generator was scheduled for Energy in that hour in the Day-Ahead Market.

4.1.7.2. DAMAP to Generators

The hourly DAMAP paid to eligible Generators is computed as the greater of zero and the sum of (a) the hourly integrated RTD interval DAMAP associated with the Generator's supply of Energy over the subject hour; (b) the hourly integrated RTD interval DAMAP associated with the Generator's supply of Regulation Service over the subject hour; and (c) the hourly integrated RTD interval DAMAP associated with the Generator's supply of Operating Reserves summed for each Operating Reserves product over the subject hour.

The determination of eligible Generators' DAMAP is illustrated formulaically in Appendix H of this manual.

4.1.7.2.1. Energy Component of DAMAP Due to Generator

The DAMAP paid to a Supplier based on its Energy schedule is determined at the RTD interval level and is integrated and summed over the hour. The determination of the Energy component of DAMAP due to eligible Generators is illustrated formulaically in Appendix H of this manual. In the event of a Generator derate; the DAM Energy schedule used in the equations detailed in this section will be reduced as described below in Section 4.1.7.2.6.

4.1.7.2.2. Energy Component of DAMAP Due to Energy Limited Resources

For any day in which (i) an Energy Limited Resource is scheduled to supply Energy, Operating Reserve Service, or Regulation Service in the Day-Ahead Market; (ii) the sum of its schedules to provide these services exceeds its bid-in upper operating limit; (iii) the Energy Limited Resource requests a reduction for Energy limitation reasons; and (iv) the NYISO modifies the Energy Limited Resource's Day-Ahead upper operating limit; the imbalance charge imposed upon the Energy Limited Resource is computed as the product of (a) the sum of its Energy, Operating Reserve Service, and Regulation Service imbalances across all twenty-four hours of the Energy day and (b) the real-time price for each service in each hour at its location. If the total margin received by the Energy Limited Resource for the twenty-four hour day is less than its Day-Ahead margin, then the Generator will receive a DAMAP.

4.1.7.2.3. Regulation Component of DAMAP Due to Generator

The DAMAP paid to a Supplier based on its Regulation Service schedule is determined as follows at the RTD interval level and is integrated and summed over the hour. In the event of a Generator derate; the DAM Regulation Service schedule used in the equations detailed in this section will be reduced as described below in Section 4.1.7.2.6. The determination of the Regulation Service component of DAMAP due to eligible Generators is illustrated formulaically in Appendix H of this manual.

Real-Time Regulation Service Schedule < DAM Regulation Service Schedule

If the eligible Generator's Real-Time Regulation Service schedule over the RTD interval is lower than its DAM Regulation Service schedule, the DAMAP paid for the Generator's Regulation Service schedule for each RTD interval is computed as the product of (a) the Generator's DAM Regulation Capacity schedule for the hour containing that RTD interval minus the Generator's Real-Time Regulation Capacity schedule in that RTD interval and (b) the Real-Time Regulation Capacity Market Price in that RTD interval minus the Generator's DAM Bid to supply Regulation Capacity for the hour containing that RTD interval; plus the product of (a) Regulation Movement MW multiplied by negative 1 and (b) the greater of (i) zero and (ii) the Real-Time Market Price for Regulation Movement in that RTD interval minus the Real-Time Regulation Movement Bid price for the hour containing the RTD interval.

Real-Time Regulation Service Schedule ≥ DAM Regulation Service Schedule

If the eligible Generator's real-time Regulation Service schedule over the RTD interval is greater than or equal to its DAM Regulation Service schedule, the DAMAP paid for the Generator's Regulation Service schedule for each RTD interval is computed as the product of (a) the Generator's DAM Regulation Capacity schedule for the hour containing that RTD interval minus the Generator's real-time Regulation Capacity schedule over the RTD interval and (b) the greater of (i) zero and (ii) the Real-Time Regulation Capacity Market Price in that RTD interval minus the Generator's real-time Bid to supply Regulation Capacity for the hour containing that RTD interval; plus the product of (a) Regulation Movement MW multiplied by negative 1 and (b) the greater of (i) zero and (ii) the Real-Time Market Price for Regulation Movement in that RTD interval minus the real-time Regulation Movement Bid price for the hour containing the RTD interval.

4.1.7.2.4. Operating Reserve Component of DAMAP Due to Generator

The DAMAP paid to a Supplier based on its Operating Reserve Service schedule for each product p of Operating Reserve scheduled is determined as follows at the RTD interval level and is integrated and summed over the hour. In the event of a Generator derate, the DAM Operating Reserves Service schedule used in the equations detailed in this section will be reduced as described below in Section 4.1.7.2.6. The determination of the Operating Reserve component of DAMAP due to eligible Generators is illustrated formulaically in Appendix H of this manual.

Real-Time Operating Reserve Schedule < DAM Operating Reserve Schedule

If the eligible Generator's real-time Operating Reserve schedule for Operating Reserve product p is lower than its DAM Operating Reserve schedule for Operating Reserve product p , the DAMAP paid for the Generator's Operating Reserve schedule for Operating Reserve product p for each RTD interval is computed as the product of (a) the Generator's DAM Operating Reserve schedule for Operating Reserve

product p for the hour containing that RTD interval minus the Generator's real-time Operating Reserve schedule for Operating Reserve product p in that RTD interval and (b) the Real-Time Market Clearing Price for Operating Reserve product p in that RTD interval minus the Generator's DAM Bid to supply Operating Reserve for Operating Reserve product p for the hour containing that RTD interval.

Real-Time Operating Reserve Schedule \geq DAM Operating Reserve Schedule

If the eligible Generator's real-time Operating Reserve schedule for Operating Reserve product p is greater than or equal to its DAM Operating Reserves Service schedule for Operating Reserve product p , the DAMAP paid for the Generator's Operating Reserve schedule for Operating Reserve product p for each RTD interval is computed as the product of (a) the Generator's DAM Operating Reserves schedule for Operating Reserve product p for the hour containing that RTD interval minus the Generator's real-time Operating Reserve schedule for Operating Reserve product p in that RTD interval and (b) the Real-Time Market Clearing Price for Operating Reserve product p in that RTD interval.

4.1.7.2.5. DAMAP Due to Limited Energy Storage Resources

DAMAP for Limited Energy Storage Resources (LESR) scheduled to provide Regulation Service is payable only for intervals in which the NYISO has reduced the real-time Regulation Service offer (in megawatts) of a LESR and the NYISO is not pursuing LESR Energy Management for such Resource for such interval. The determination of DAMAP due to an eligible LESR is illustrated formulaically in Appendix H of this manual.

Real-Time Regulation Service Schedule $<$ DAM Regulation Service Schedule and Real-Time Regulation Capacity Market Price $>$ DAM Regulation Capacity Bid Price

If, in the hour containing the RTD interval, the LESR's real-time Regulation Service schedule is less than its DAM Regulation Service schedule and the Real-Time Regulation Capacity Market Price is greater than the Day-Ahead Regulation Capacity Bid price, then the DAMAP paid for the Resource's Regulation schedule is computed as the product of (a) the Generator's DAM Regulation Capacity schedule for the hour containing that RTD interval minus its real-time Regulation Capacity schedule in that RTD interval; (b) the Real-Time Regulation Capacity Market Price in that RTD interval minus the Generator's DAM Bid to supply Regulation Capacity for the hour containing that RTD interval; and (c) the LESR's Performance Index over the RTD interval; plus the product of (a) Regulation Movement MW multiplied by negative 1 and (b) the greater of (i) zero and (ii) the Real-Time Market Price for Regulation Movement in that RTD interval minus the real-time Regulation Movement Bid price for the hour containing that RTD interval. The calculation of the Performance Index is described in Appendix G of this manual.

***Real-Time Regulation Service Schedule < DAM Regulation Service Schedule and
Real-Time Regulation Capacity Market Price ≤ DAM Regulation
Capacity Bid Price***

If, in the hour containing the RTD interval, the LESR's real-time Regulation Service schedule is less than its DAM Regulation Service schedule and the Real-Time Regulation Capacity Market Price is less than or equal to the Day-Ahead Regulation Capacity Bid price, then the DAMAP paid for the Resource's Regulation schedule is computed as the product of (a) the Generator's DAM Regulation Capacity schedule for the hour containing that RTD interval minus its real-time Regulation Capacity schedule in that RTD interval; (b) the Real-Time Market Price for Regulation Capacity in that RTD interval minus the Generator's DAM Bid to supply Regulation Capacity for the hour containing that RTD interval; plus the product of (a) Regulation Movement MW multiplied by negative 1 and (b) the greater of (i) zero and (ii) the Real-Time Market Price for Regulation Movement in that RTD interval minus the real-time Regulation Movement Bid price for the hour containing that RTD interval.

Real-Time Regulation Service Schedule ≥ DAM Regulation Service Schedule

If the LESR's real-time Regulation Service schedule is greater than or equal to its DAM Regulation Service schedule in the hour containing the RTD interval, then the DAMAP paid for the Resource's Regulation schedule is computed as the product of (a) the Generator's DAM Regulation Capacity schedule for the hour containing that RTD interval minus its real-time Regulation Capacity schedule in that RTD interval and (b) the greater of (i) zero and (ii) the Real-Time Regulation Capacity Market Price in that RTD interval minus the Generator's real-time Bid to supply Regulation Capacity for the hour containing that RTD interval; plus the product of (a) Regulation Movement MW multiplied by negative 1 and (b) the greater of (i) zero and (ii) the Real-Time Market Price for Regulation Movement for the RTD interval minus the real-time Regulation Movement Bid price for the hour containing the RTD interval.

4.1.7.2.6. Adjustments to DAMAP Resulting from Generator Derates

Suppliers that request and are granted a derate of their Real-Time Operating Capacity, but are otherwise eligible to receive DAMAP, may receive a payment up to a Capacity level consistent with their revised Emergency Upper Operating Limit or Normal Upper Operating Limit, whichever is applicable. The foregoing rule is also applied to a Generator, otherwise eligible for a DAMAP, in hours in which the NYISO has derated the Generator's Operating Capacity in order to reconcile the NYISO's dispatch with the Generator's actual output, or to address reliability concerns that arise because the Generator is not following Base Point Signals.

If a Supplier's derated Real-Time Operating Capacity is lower than the sum of its DAM Energy, Regulation Service, and Operating Reserve Service schedules, the Generator's DAM schedules for Energy,

Regulation Service, and Operating Reserves Service used to compute the Generator's DAMAP will be reduced respectively when applied to the settlement rules described above. The reductions to an eligible Generator's DAM Energy, Regulation Service, and Operating Reserves Service schedules in computing the Generator's DAMAP, described above, are illustrated formulaically in Appendix H of this manual.

4.1.7.3. DAMAP to Demand Side Resources Scheduled to Provide Regulation Service and Operating Reserves Service

The hourly DAMAP for Demand Side resources scheduled to provide Regulation Service and Operating Reserves for each respective Operating Reserve product p is computed at the RTD interval level and is integrated and summed over the hour. The hourly DAMAP for Demand Side resources scheduled to provide Regulation Service and Operating Reserves for each respective Operating Reserve product p is computed as the greater of (a) zero and (b) the sum of the Regulation Service DAMAP and Operating Reserve DAMAP for each respective Operating Reserve product p due to the Resource over the hour, as described below in Sections 4.1.7.3.1 and 4.1.7.3.2, respectively, and as illustrated formulaically in Appendix H of this manual.

4.1.7.3.1. Regulation Service Component of DAMAP Due to Demand Side Resources

The DAMAP paid to a Demand Side Resource based on its Regulation Service schedule is determined as follows at the RTD interval level and is integrated and summed over the hour.

Real-Time Regulation Service Schedule < DAM Regulation Service Schedule

If the Demand Side Resource's Real-Time Regulation Service schedule is less than its Day-Ahead Regulation Service schedule, then the DAMAP paid for the Demand Side Resource's Regulation Service schedule for each RTD interval is computed as the product of (a) the Resource's DAM Regulation Capacity schedule for the hour containing that RTD interval minus the Resource's Real-Time Regulation Capacity schedule in that RTD interval and (b) the Real-Time Regulation Capacity Market Price in that RTD interval minus the Resource's DAM Bid to supply Regulation Capacity for the hour containing that RTD interval; plus the product of (a) Regulation Movement MW multiplied by negative 1 and (b) the greater of (i) zero and (ii) the Real-Time Market Price for Regulation Movement for the RTD interval minus the Real-Time Regulation Movement Bid price for the hour containing the RTD interval.

Real-Time Regulation Service Schedule \geq DAM Regulation Service Schedule

If the Demand Side Resource's Real-Time Regulation Service schedule is greater than or equal to its DAM Regulation Service schedule, then the DAMAP paid for the Demand Side Resource's Regulation Service schedule for each RTD interval is computed as the product of (a) the Resource's DAM Regulation Capacity schedule for the hour containing that RTD interval minus the Resource's Real-Time Regulation Service schedule in that RTD interval and (b) the greater of (i) zero and (ii) the Real-Time Regulation Capacity Market Price in that RTD interval minus the Resource's Real-Time Bid to supply Regulation Capacity for the

hour containing that RTD interval; plus the product of (a) Regulation Movement MW multiplied by negative 1 and (b) the greater of (i) zero and (ii) the Real-Time Market Price for Regulation Movement for the RTD interval minus the Real-Time Regulation Movement Bid price for the hour containing the RTD interval.

4.1.7.3.2. Operating Reserve Component of DAMAP Due to Demand Side Resources

The DAMAP paid to a Demand Side Resource based on its Operating Reserve schedules is determined as follows:

Real-Time Operating Reserve Schedule < DAM Operating Reserve Schedule

If the Demand Side Resource's Real-Time schedule for a given Operating Reserve product p is less than its Day-Ahead Operating Reserve schedule for Operating Reserve product p , then the DAMAP paid for the Demand Side Resource's Operating Reserve schedule for Operating Reserve product p for each RTD interval is computed as the product of (a) the Resource's DAM Operating Reserves Service schedule for the hour containing that RTD interval minus the Resource's Real-Time Operating Reserves Service schedule in that RTD interval; (b) the Real-Time Market Clearing Price for Operating Reserves Service in that RTD interval minus the Resource's DAM Bid to supply Operating Reserves Service for the hour containing that RTD interval; and (c) the Reserves Performance Index computed for the Demand Side Resource in the RTD interval, as described in section in Section 4.1.7.3.3, below.

Real-Time Operating Reserve Schedule \geq DAM Operating Reserve Schedule

If the Demand Side Resource's Real-Time schedule for Operating Reserve product p is greater than or equal to its Day-Ahead Operating Reserve schedule for Operating Reserve product p , then the DAMAP paid for the Demand Side Resource's Operating Reserve schedule for Operating Reserve product p for each RTD interval is computed as the product of (a) the Resource's DAM Operating Reserves Service schedule for the hour containing that RTD interval minus the Resource's Real-Time Operating Reserves Service schedule in that RTD interval; (b) the Real-Time Market Clearing Price for Operating Reserves Service in that RTD interval; and (c) the Reserve Performance Index computed for the Demand Side Resource in the RTD interval, as described in section in Section 4.1.7.3.3, below.

4.1.7.3.3. Reserve Performance Index for Demand Side Resource Suppliers of Operating Reserves

A Reserve Performance Index (RPI) is computed by the NYISO for the purpose of calculating the DAMAP for Demand Side Resources scheduled to provide Operating Reserves in the Day-Ahead Market. The RPI takes into account the actual Demand Reduction achieved by the Supplier of Operating Reserves following the NYISO's instruction to convert Operating Reserves to Demand Reduction.

The RPI is a factor with a value between 0.0 and 1.0 inclusive. For each interval in which the NYISO has not instructed the Demand Side Resource to convert its Operating Reserves to Demand Reduction, the

Resource's RPI is set to a value of one. For each interval in which the NYISO has instructed the Demand Side Resource to convert its Operating Reserves to Demand Reduction, the RPI is calculated as the greater of (a) zero and (b) the lesser of (i) one and (ii) the sum of (A) one-tenth and (B) the quotient of (c) the Average Actual Demand Reduction measured from the Resource over the RTD interval and (d) the Average scheduled Demand Reduction measured for the Resource over the RTD interval. In the event that the Average Actual Demand Reduction measured from the Demand Side Resource over the RTD interval zero or less, the RPI is set to zero.

The determination of a Demand Side Resource's RPI is illustrated formulaically in Appendix G of this manual.

4.1.8. Cost Recovery for Units Responding to Local Reliability Rule G.2 or G.3

4.1.8.1. Eligibility for Cost Recovery

A Supplier designated pursuant to the New York State Reliability Council's Local Reliability Rule G.2 -- Loss of Generator Gas Supply (New York City) or G.3 -- Loss of Generator Gas Supply (Long Island), as being required to burn an alternate fuel at designated minimum levels based on forecast Load levels in Load Zones J or K, will be eligible to recover costs associated with burning the required alternate fuel. The Supplier must register with the NYISO as described in NYISO Procedures. The periods of time for which Local Reliability Rule G.2 or G.3 is invoked and in which the Eligible Unit burns its required alternate fuel, including that period of time required to move into and out of Rule G.2 or G.3 compliance, will be referred to as the Eligibility Period.

4.1.8.2. Variable Operating Cost Recovery

For Eligibility Periods, the Eligible Unit will recover costs that vary with the amount of alternate fuel burned because Local Reliability Rule G.2 or G.3 was invoked ("variable operating costs") if: (i) such costs are not reflected in the reference level for that Eligible Unit for the hours included in the Eligibility Period, and (ii) the hour is one for which the commodity cost of the alternate fuel including taxes and emission allowance costs is greater than the commodity cost for natural gas, including taxes and emission allowance costs, as determined by the NYISO. These relative commodity cost determinations will use the same indices used by the NYISO to establish daily Reference Levels. Variable operating costs will include the commodity cost, associated taxes and emission allowance costs, of the required alternate fuel burned during an Eligibility Period pursuant to Rule G.2 or G.3.

4.1.8.3. Additional Cost Recovery

An eligible unit that seeks to recover costs incurred in connection with its compliance with Rule G.2 or

G.3, in addition to the commodity cost, associated taxes and emission allowance cost recovery addressed here, will negotiate an Implementation Agreement with the NYISO. The eligible unit and the NYISO will consult with and consider the input of the New York State Public Service Commission, and the Transmission Owner designated by Rule G.2 or G.3. Such Implementation Agreements will specify, among other terms and conditions, the facilities (or portions of facilities) used to meet obligations under Rule G.2 or G.3. The Implementation Agreement will indicate the rate to be charged during the period of the Implementation Agreement to recover such additional costs.

The Implementation Agreement may also include costs in addition to commodity cost, associated taxes and emission allowance costs of the alternate fuel incurred in connection with compliance with Rule G.2 or G.3 that vary with the amount of alternate fuel burned because G.2 or G.3 was invoked. These variable costs will be paid as variable operating costs so as to not duplicate payments.

Each such Implementation Agreement will last for one or more Capability Periods and will commence at the beginning of a Capability Period unless another date is approved by the Commission. If the Eligible Unit and the NYISO reach agreement on the terms and conditions of the Implementation Agreement, the NYISO will file it with the Commission for its review and acceptance.

In the event that the Eligible Unit and the NYISO have not come to an agreement six months prior to the beginning of the Capability Period that the Implementation Agreement is intended to govern, then either one of them may request the assistance of the Commission's Dispute Resolution Service. If the Dispute Resolution Service agrees to provide its assistance the Eligible Unit and the NYISO will participate in whatever dispute resolution process the Dispute Resolution Service may recommend. The Commission's Dispute Resolution Service may include other stakeholders to the extent confidentiality protections are in place. If, however, there is no agreement four months prior to the beginning of the relevant Capability Period then the Eligible Unit and the NYISO may each file an unexecuted Implementation Agreement for the Commission's review and acceptance.

In the event that any of these provisions are modified prior to the termination date of any Commission-accepted Implementation Agreement, such Implementation Agreement will remain in full force and effect until it expires in accordance with its contractual terms and conditions.

Rules for establishing Eligibility Periods are specified in NYISO Procedures.

4.1.8.4. Billing

Payments made by the NYISO to the Eligible Unit to pay variable operating costs and to pay the rate established by the Implementation Agreement will be in addition to any LBMP, Ancillary Service or other

revenues received as a result of the Eligible Unit's Day-Ahead or Real-Time dispatch for that day. Payment by the NYISO of variable operating costs will be based on the Eligibility Period, quantity of alternate fuel burned, and relative costs of alternate fuel compared to natural gas. Payment by the NYISO of the rate established in the Implementation Agreement for costs incurred other than variable operating costs will be made as part of the NYISO billing cycle regardless of whether an alternate fuel is burned pursuant to G.2 or G.3 and regardless of the relative cost of the alternate fuel compared to natural gas reflected in reference levels.

4.1.8.5. Other Provisions

The NYISO will make available for the Transmission Owner in whose subzone the Generator is located: (i) the identity of Generators determined by the NYISO to be eligible to recover the costs associated with burning the required alternate fuel; (ii) the start and stop hours for each claimed Eligibility Period and (iii) the amount of alternate fuel for which the Generator has sought to recover variable operating costs.

4.1.9. Performance Tracking

The NYISO administers a Performance Tracking System (PTS) to compute the difference between the Energy actually supplied and the Energy scheduled by the NYISO for all Suppliers located within the NYCA. The PTS is used to measure compliance with criteria associated with the provision of Energy and Ancillary Services as set forth in the NYISO Procedures. The PTS is also used to report metrics for Loads. The PTS processes affecting Regulation Service settlements are described formulaically in Appendix G and referenced by the Regulation Service settlement formulae in Appendix I.

4.1.10. Energy Storage Resource Charging at Retail- Generator Rebate

When a Load Serving Entity requires an Energy Storage Resource, including an Energy Storage Resource participating in an Aggregation, to pay a retail rate for its charging withdrawals, the ISO shall issue a credit to the affected Customer and assess an offsetting charge to the applicable Load Serving Entity in accordance with Services Tariff Section 7.2.8.

4.1.11. Energy Storage Resource Transmission Service Charges

Energy Storage Resources will also pay a TSC charge directly to the Transmission Owner in whose Transmission District the Energy Storage Resource is located for Actual Energy Withdrawals by the Energy Storage Resource when it is not providing a service as described in Appendix A. Aggregations containing one or more Energy Storage Resources shall pay a TSC directly to the Transmission Owner in whose Transmission District the Aggregation is located when (i) the Aggregation is not providing a service, and

(ii) the sum of the Aggregation's Energy injections and Demand Reductions, less the Aggregation's Energy withdrawals, is negative. These withdrawals will be calculated by the NYISO and reported to both the generator and Transmission Owner in their respective settlement statements and reports.

4.2. Energy Supplier Settlement – Demand Reduction Providers

4.2.1. DAM Energy Supplier Settlement – Demand Reduction Providers

For each Demand Reduction Provider that bids a Demand Reduction into the DAM and is scheduled to provide Energy from the Demand Reduction, the LSE providing Energy service to the Demand Side Resource that accounts for the Demand Reduction is paid the product of: (a) the DAM hourly LBMP at the applicable Demand Reduction Bus; and (b) the hourly demand reduction scheduled Day-Ahead (in MW). Each Demand Reduction Provider that bids a Demand Reduction into the DAM and is scheduled to provide Energy through Demand Reduction receives a Demand Reduction Incentive Payment equal to the product of: (a) the DAM hourly LBMP at the Demand Reduction bus; and (b) the lesser of the actual hourly Demand Reduction or the scheduled hourly Demand Reduction (in MW). The calculation of DAM Demand Reduction settlements is further described in Appendix B.

4.2.2. BPCG for Demand Reduction in the Day-Ahead Market

The NYISO will determine if a Demand Reduction Provider eligible under Section 4.2.2.1 of this manual for a Bid Production Cost Guarantee payment for Demand Reduction in the Day-Ahead Market will not recover its Day-Ahead Curtailment Initiation Cost and its Day-Ahead Demand Reduction Bid through Day-Ahead LBMP revenues. Such determination will be made for an entire Day-Ahead Market day, and such determination will be made separately for each Demand Side Resource. On the basis of such determination, the NYISO will pay a Bid Production Cost Guarantee payment to the Demand Reduction Provider pursuant to the algorithms described in Appendix E.

4.2.2.1. Eligibility for BPCG for Demand Reduction in the Day-Ahead Market

A Demand Reduction Provider that bids a Demand Side Resource that is committed by the NYISO in the Day-Ahead Market to provide Demand Reduction will be eligible to receive a Bid Production Cost Guarantee payment under this Section 4.2.2.

4.2.2.2. Formula for BPCG for Demand Reduction in the Day-Ahead Market

The formula for determining BPCG for Demand Reduction in the Day-Ahead Market is detailed in Appendix E of this manual.

4.2.3. Balancing Market Energy Supplier Settlement – Demand Reduction Providers

When actual Demand Reduction over an hour from a Demand Reduction Provider that is also the LSE providing Energy service to the Demand Side Resource(s) that produced the reduction is less than the Demand Reduction scheduled for that hour, that LSE is charged a Demand Reduction imbalance charge consisting of the product of: (a) the greater of the DAM LBMP or the Real-Time LBMP for that hour and (b) the difference between the scheduled Demand Reduction and the actual Demand Reduction in that hour.

When actual Demand Reduction over an hour from a Demand Reduction Provider that is not the LSE providing Energy service to the Demand Side Resource(s) that produced the reduction is less than the Demand Reduction scheduled over that hour, the LSE providing Energy service to the Demand Reduction Provider's Demand Side Resource(s) is charged a Demand Reduction imbalance charge equal to the product of (a) the Day-Ahead LBMP calculated for that hour for the applicable Load bus and (b) the difference between the scheduled Demand Reduction and the actual Demand Reduction at that bus in that hour. In addition, the Demand Reduction Provider is charged an amount equal to (a) the product of (i) the higher of the DAM LBMP or the Real-Time LBMP calculated for that hour for the applicable Load bus, and (ii) the difference between the scheduled Demand Reduction and the actual Demand Reduction at that bus in that hour and (b) minus the amount paid by the LSE providing service to the Demand Reduction Provider's Demand Side Resource(s).

4.2.3.1. Determination of Amount of Energy Curtailed

The amount of Demand Reduction achieved by the Demand Reduction Provider's Demand Side Resource is determined as the difference between the respective LSE's actual Energy withdrawal and its baseline load (i.e., Economic Customer Baseline Load, or ECBL). The ECBL is computed by the Demand Reduction Provider's Meter Services Entity (MSE). Performance data may not be available to the MSE within the time necessary to report the actual Demand Reduction for inclusion in the initial monthly invoicing of the respective service month; therefore, the Demand Side Resource is assumed to have achieved its scheduled Demand Reductions in the initial monthly invoicing of the service month. When settlements are resettled four months later, the Demand Reduction is computed as the greater of (a) 0 MW and (b) the lesser of (i) the Demand Reduction computed by the MSE and (ii) the scheduled Demand Reduction. The determination of a LSE's ECBL and the Demand Side Resource's Demand Reduction are detailed in Section 24.2 of the NYISO OATT.

4.3. Energy Supplier Settlement – LBMP Energy Imports

4.3.1. DAM Energy Supplier Settlement – LBMP Energy Imports

Each Supplier whose External Generator is scheduled to sell Energy in the DAM is paid the product of: (a) the DAM hourly LBMP at the Point of Receipt (i.e., Proxy Bus) of the transaction and (b) the External Generator's hourly Energy schedule. The calculation of the DAM Energy Supplier settlement for LBMP Market Energy Imports is represented formulaically in Appendix B.

4.3.2. Day-Ahead BPCG for Imports

The NYISO will determine if a Supplier supplying an Import and eligible under Section 4.3.2.1 of this manual for a Day-Ahead Bid Production Cost Guarantee payment will not recover its Day-Ahead Decremental Bid through Day-Ahead LBMP revenue and Day-Ahead Imputed LBMP Revenue. Such determination will be made for an entire Day-Ahead Market day and such determination will be made separately for each Import transaction. On the basis of such determination, the NYISO will pay a Day-Ahead Bid Production Cost Guarantee payment to the Supplier pursuant to the algorithm in Appendix E.

4.3.2.1. Eligibility to Receive a Day-Ahead BPCG for Imports

A Supplier that bids an Import that is committed by the NYISO in the Day-Ahead Market will be eligible to receive a Day-Ahead Bid Production Cost Guarantee payment.

4.3.2.2. BPCG Calculated by Transaction ID

For purposes of calculating a Day-Ahead Bid Production Cost Guarantee payment for an Import under this Section 4.3.2, the NYISO will treat the Import as being from a single Resource for all hours of the Day-Ahead Market day in which the same Transaction ID is used, and the NYISO will treat the Import as being from a different Resource for all hours of the Day-Ahead Market day in which a different Transaction ID is used.

4.3.2.3. Formula for Day-Ahead BPCG for Imports

The formula for determining Day-Ahead BPCG for Imports is detailed in Appendix E of this manual.

4.3.3. Balancing Market Supplier Settlement – LBMP Energy Imports

A Supplier whose External Generator is scheduled after the determination of the Day-Ahead schedule, or who is scheduled to supply additional or less Energy to the LBMP Energy market after the determination of the Day-Ahead schedule, is paid the product of: (a) actual Energy scheduled by RTD in each RTD interval, minus the amount of Energy scheduled Day-Ahead for the External Generator in that hour, in megawatt hours; and (b) the Real-Time LBMP at the Point of Receipt (i.e., Proxy Bus), in \$/MWh. The calculation of

the Balancing Market Energy Supplier settlement for LBMP Market Energy Imports is represented formulaically in Appendix B.

4.3.3.1. Financial Impact Charge for LBMP Energy Import Transactions Failing the NYISO Checkout Process

If the checkout failure occurred for reasons within the Supplier's or Transmission Customer's control, the Supplier or Transmission Customer that was scheduled to make the injection is charged a Financial Impact Charge (FIC), computed as the product of: (1) the amount of the Import scheduled by RTC minus the External Generator's Actual Energy Injections and (2) the greater of the Real-time Market Congestion Component of the LBMP in the relevant interval, or zero.

The Financial Impact Charge settlement for LBMP Energy Import Transactions failing the NYISO checkout process is illustrated formulaically in Appendix B.

4.3.4. Real-Time BPCG for Imports

External transactions are not eligible to receive Bid Production Cost Guarantee payments in the Real-Time Market.

4.3.5. Import Curtailment Guarantee Payments

4.3.5.1. Eligibility for an Import Curtailment Guarantee Payment for an Import Curtailed by the NYISO

In the event that the Energy injections for an Import scheduled by RTC or RTD at a Proxy Generator Bus, other than a CTS Enabled Proxy Generator Bus, are Curtailed at the request of the NYISO, and (i) the real-time Energy Profile MW is equal to or greater than the Day-Ahead Energy Schedule for that interval, and (ii) the real-time Decremental Bid is less than or equal to the default real-time Decremental Bid amount as established by NYISO procedures, then the Supplier or Transmission Customer that is subjected to the Curtailment, in addition to the charge for Energy Imbalance, will be eligible for an Import Curtailment Guarantee Payment as described below. Suppliers scheduling Imports at CTS Enabled Proxy Generator Buses shall not be eligible for Import Curtailment Guarantee payments for those Transactions. The NYISO Customer Settlements Department will determine whether the Transaction associated with an injection failed for reasons within the Supplier's or Transmission Customer's control.

4.3.5.2. Formula for an Import Curtailment Guarantee Payment for an Import Curtailed by the NYISO

The formula for determining an Import Curtailment Guarantee Payment for an Import Curtailed by the NYISO is detailed in Appendix E of the manual.

4.4. Energy Supplier Settlement – Virtual Energy Suppliers

4.4.1. DAM Energy Supplier Settlement – Virtual Suppliers

Each Customer that submits a Virtual Supply Transaction Bid into the NYISO DAM and has a schedule accepted to sell Energy in a Load Zone in the DAM will receive a payment equal to the product of (a) the DAM hourly zonal LBMP for that Load Zone; and (b) the hourly scheduled Energy for the Customer in that Load Zone. The calculation of the DAM Energy Supplier settlement for Virtual Supply is represented formulaically in Appendix B of this manual.

4.4.2. Balancing Market Energy Supplier Settlement – Virtual Suppliers

Since Virtual Supply Transactions, by their virtual nature, result in no Actual Energy Injections, the Supplier is charged for the Energy imbalance equal to the product of: (a) the Supplier's Real-Time LBMP calculated in that hour for that load zone; and (b) the difference between the Supplier's Actual Energy Injection (i.e., 0 MW) and the scheduled Day-Ahead Energy injection for that hour in that load zone. The calculation of the Balancing Market Energy Supplier settlement for Virtual Supply is represented formulaically in Appendix B of this manual.

4.5. Energy Settlement – Emergency Demand Response Program Participants

If the NYISO activates the Emergency Demand Response Program (EDRP), Curtailment Service Providers, including Special Case Resources, which cause a verified demand reduction in response to the activation of the EDRP, are paid for four hours of demand reduction or for the period of time that the EDRP is activated, whichever is greater.

If the NYISO activates the EDRP for more than four hours, each Curtailment Service Provider is paid the product of (a) the higher of \$500/MWh or the zonal Real-Time LBMP and (b) the verified demand reduction, in megawatt hours starting with the hour specified by the NYISO as the starting time of the activation, or, in the event that the NYISO specified that the demand reduction begin as soon as possible, starting with the hour that the Curtailment Service Provider began its response.

If the NYISO activates the EDRP for four hours or less, each Curtailment Service Provider is paid as if the EDRP had been activated for four hours. Each Curtailment Service Provider that causes a verified demand reduction is paid the product of (a) the higher of \$500/MWh or the zonal Real-Time LBMP per hour for the duration of the NYISO activation of the Emergency Demand Response Program or two hours whichever is greater, starting with the hour specified by the NYISO as the starting time of the activation, or, in the event that the NYISO specified that the demand reduction begin as soon as possible, starting with the

hour that the Curtailment Service Provider began its response and (b) the amount of verified demand reduced, in megawatt hours. Each Curtailment Service Provider is paid the zonal Real-Time LBMP per megawatt hour of verified demand reduced for the remainder of the four hour minimum payment period, provided that a verified demand reduction was effectuated by the time specified in the NYISO's notice.

4.5.1. Concurrent Enrollment in More Than One Demand Response Program

If a Curtailment Service Provider, including Special Case Resources, is enrolled in both the Emergency Demand Response Program and the Demand Side Ancillary Service Program, verifiable load reduction will be applied first to the supply of Operating Reserves or Regulation. Any remaining verifiable load reduction will be applied to the Emergency Demand Response Program.

4.5.2. BPCG for Special Case Resources

The NYISO will determine if a Supplier eligible under Section 4.5.2.1 of this manual for a Bid Production Cost Guarantee payment for a Special Case Resource will not recover its Minimum Payment Nomination through Real-Time LBMP revenues. Such determination will be made for an entire Dispatch Day, and such determination will be made separately for each Special Case Resource. On the basis of such determination, the NYISO will make a Bid Production Cost Guarantee payment to the Supplier pursuant to the methodology in Section 4.5.1.2 of this manual.

4.5.2.1. Eligibility for Special Case Resources BPCG

Any Supplier that bids a Special Case Resource that is committed by the NYISO for an event in the Real-Time Market will be eligible to receive a Bid Production Cost Guarantee payment under this Section 4.5.1. Suppliers will not be eligible for a Special Case Resource Bid Production Cost Guarantee payment for the period over which a Special Case Resource is performing a test.

4.5.2.2. Methodology for Determining Special Case Resources BPCG

A Special Case Resource Bid Production Cost Guarantee payment will be made when the Minimum Payment Nomination for any Special Case Resource committed by the NYISO over the period of requested performance or four (4) hours, whichever is greater, exceeds the LBMP revenue received for performance by that Special Case Resource; provided, however, that the NYISO will set to zero the Minimum Payment Nomination for Special Case Resource Capacity in each interval in which such Capacity was scheduled Day-Ahead to provide Operating Reserves, Regulation Service, or Energy.

5. Ancillary Services Supplier Settlements

The provisions herein describe the determination of settlements for Ancillary Services Suppliers. The NYISO Ancillary Services Manual should be consulted for eligibility, qualification and scheduling criteria regarding the provision of Ancillary Services. The NYISO Ancillary Services Manual is located on the NYISO website at:

<https://www.nyiso.com/manuals-tech-bulletins-user-guides>

5.1. Voltage Support Service

5.1.1. Method for Determining the Payments for Voltage Support Service

Payments to synchronous Generators and synchronous condensers eligible to provide Voltage Support Service (VSS) are based upon a fixed dollar amount per MVar (annual dollar per MVar rate), as specified in Rate Schedule 2 (Section 15.2) of the NYISO Services Tariff, and the tested MVar capability as determined by annual capability testing performed by the Generator and verified by the NYISO. The rate provided in Rate Schedule 2 (Section 15.2) of the Services Tariff is used to calculate payments to all eligible and qualified Suppliers providing VSS as applied on a Resource-specific basis. Suppliers must be electrically located within the NYCA to qualify for VSS payment.

Aggregations are not eligible to provide Voltage Support Service.

5.1.2. Payments for Voltage Support Service Provided by Suppliers with Installed Capacity Contracts

Each month, Suppliers of VSS, whose Resource(s) meet the requirements to supply Installed Capacity, as described in Article 5 (Section 5) of the NYISO Services Tariff, and are under contract to supply Installed Capacity will receive one-twelfth (1/12th) of their annual payment for VSS. The annual payment to the Supplier is calculated as the product of the annual dollar per MVar rate and the tested MVar capability of the Generator or synchronous condenser, less the demonstrated performance that is within the standard power factor range, pursuant to section 15.2 of the NYISO Services Tariff. These settlement provisions are described formulaically in Appendix I.

5.1.3. Payments for Voltage Support Service Provided by Suppliers without Installed Capacity Contracts

Each month, Suppliers of VSS, whose Generators are not under contract to supply Installed Capacity, Suppliers of VSS with synchronous condensers, and Qualified Non-Generator Voltage Support Resources other than the Cross-Sound Scheduled Line receive one-twelfth (1/12th) of their annual payment, pro-

rated by the number of hours that the Generator, synchronous condenser, or Qualified Non-Generator Voltage Support Resource other than the Cross-Sound Scheduled Line operated in that month, as recorded by the NYISO. The Supplier's annual payment is calculated as: (i) in the case of Generators and synchronous condensers, the product of the annual dollar per MVar rate and the tested MVar capability of the Generator or synchronous condenser; and (ii) in the case of Qualified Non-Generator Voltage Support Suppliers, other than the Cross-Sound-Scheduled Line, the product of the annual dollar per MVar rate and its tested MVar capability less the demonstrated performance that is within the standard power factor range, as determined pursuant to the NYISO Procedures. These settlement provisions are described formulaically in Appendix I of this manual.

If a synchronous condenser or Qualified Non-Generator Voltage Support Resource energizes at the request of the NYISO in order to provide VSS, the Resource is compensated for the cost of the Energy it consumes to energize converters and other equipment required to provide VSS.

5.1.4. Payments to the Cross-Sound Scheduled Line and CHPE MTF for Voltage Support Services Provided

If the Cross-Sound Scheduled Line and the CHPE MTF are Suppliers of VSS, then each month, the Cross-Sound Scheduled Line and the CHPE MTF will each receive one-twelfth (1/12th) of their respective annual payments, pro-rated by the number of hours each line was energized during the month, as recorded by the NYISO. The annual payment is calculated as the product of the annual dollar per MVar rate and the tested Reactive Power (MVar) capability measured at maximum real power flow, less the demonstrated performance that is within the standard power factor range, pursuant to section 15.2 of the NYISO Services Tariff, as described in the NYISO Ancillary Services Manual. These settlement provisions are described formulaically in Appendix I of this manual.

5.1.5. Payments for Lost Opportunity Cost

A Supplier providing VSS from a Generator that is being dispatched by the NYISO also receives a payment for Lost Opportunity Costs (LOCs) in the event the NYISO dispatches or directs the Generator to reduce its real power (MW) output below its Economic Operating Point in order to allow the unit to produce or absorb more Reactive Power (MVar), unless the Supplier is already receiving Day-Ahead Margin Assurance Payments for the reduction.

The LOC payment is calculated as the product of: (a) the amount of the reduction in output below the Generator's Economic Operating Point; (b) the duration of the reduction; and (c) the Real-Time LBMP at the Generator's bus minus the Generator's Energy Bid for the reduced output of the Generator. These settlement provisions are described formulaically and illustrated graphically in Appendix I of this manual.

5.1.6. Failure to Perform by Suppliers

A Resource or Qualified Non-Generator Voltage Support Resource will have failed to provide voltage support if it:

- Fails at the end of 10 minutes to be within 5% (+/-) of the requested Reactive Power (MVARs) level of production or absorption as requested by the NYISO or applicable Transmission Owner for levels below its Normal Operating limit, which must be at least 90% of its Dependable Maximum Net Capability (DMNC);
- Fails at the end of 10 minutes to be at 95% or greater of the Resource's demonstrated Reactive Power capability (tested at its Normal Operating Limit or at 90% of its DMNC, whichever is greater in MW) in the appropriate lead or lag direction when requested to go to maximum lead or lag reactive capability by the NYISO or applicable Transmission Owner; or
- Fails to maintain its Automatic Voltage Regulator (AVR) in-service and in automatic voltage control mode, or fails to commence timely repairs to the AVR.

Any resource that fails to provide voltage support when it is being paid to provide voltage support and is not otherwise excused pursuant to a forced outage, derate or maintenance outage will be penalized, as described below.

5.1.6.1. Failure to Respond to NYISO's Request for Steady State Voltage Control

If a Resource or a Qualified Non-Generator Voltage Support Resource fails to comply with the NYISO's request for steady-state voltage control, the NYISO will withhold Voltage Support Service payments from the non-complying Supplier equivalent to one-twelfth (1/12th) of the annual payment for that specific Resource or a Qualified Non-Generator Voltage Support Resource (or an amount equal to the last month's voltage support payment made to it, if it is not an Installed Capacity provider). The Supplier will also be liable for any additional cost in procuring replacement Voltage Support Service including LOC incurred by the NYISO as a direct result of the Supplier's non-performance. For each instance of failure to perform, the non-complying Supplier will be subject to the charges described herein. If a Resource fails to comply with the NYISO's request on three (3) separate days, within a thirty (30) day period, then upon the third occurrence, the non-complying Supplier will no longer be eligible for Voltage Support Service payments for service provided by that Resource or Qualified Non-Generator Voltage Support Resource.

Reinstatement of Payments

The NYISO may reinstate payments once the Supplier complies with the following conditions to the NYISO's satisfaction:

- the Supplier's Resource or Qualified Non-Generator Voltage Support Resource must successfully perform a Reactive Power (MVAR) capability test, and
- provide VSS for 30 consecutive days without any compliance failures. No payments for VSS or LOC will be made to the Supplier during this period.

5.1.6.2. Failure to Provide Voltage Support Service When a Contingency Occurs on the NYS Power System

If a Supplier's Resource or Qualified Non-Generator Voltage Support Resource fails to respond to a contingency, based on NYISO review and analysis, the NYISO will withhold VSS payments from the non-complying Supplier as follows. Upon initial failure, the NYISO will withhold from the Supplier one-twelfth (1/12th) of the annual payment for the specific Resource or Qualified Non-Generator Voltage Support Resource (or an amount equal to the last month's voltage support payment made to it, if it is not an Installed Capacity provider). In the event of a second Failure within the same thirty (30) day period, the NYISO will withhold from the Supplier one-fourth (1/4th) of the annual payment for the specific Resource or Qualified Non-Generator Voltage Support Resource (or an amount equal to the last three (3) months' voltage support payments made to it, if it is not an Installed Capacity provider).

Reinstatement of Payments

The Supplier that is in violation will be prohibited from receiving VSS payments for the non-complying Resource or Qualified Non-Generator Voltage Support Resource until the Supplier complies with the following conditions to the NYISO's satisfaction:

- the Supplier's Resource or Qualified Non-Generator Voltage Support Resource successfully performs a Reactive Power (MVAR) capability test, and
- provides VSS for 30 consecutive days without any compliance failures. No payments for VSS or LOC will be made to the Supplier during this period.

5.1.6.3. Failure to Maintain Automatic Voltage Regulator in Service

A Resource will be disqualified as a Supplier of VSS after it fails to maintain the AVR in operation and fails to commence timely repairs following a failure of the AVR within a 30-day period.

Reinstatement of Payments

The Supplier will not receive VSS payments for the disqualified Resource until the Supplier complies with the following conditions:

- The Supplier provides documentation to the NYISO of the completion of the repairs;
- The Supplier's Resource successfully performs a Reactive Power (MVAR) capability test; and
- The Resource provides VSS for 30 consecutive days without any compliance failures. No payments for VSS or VSS LOC are made to the Supplier during this period.

5.2. Regulation and Frequency Response Service

5.2.1. Regulation Service Settlements – Day-Ahead Market

Each Supplier that is scheduled Day-Ahead to provide Regulation Service is paid the product of the Day-Ahead Regulation Capacity Market Price in each hour for which its Generator is scheduled and the amount

of Regulation Capacity that the Generator is scheduled Day-Ahead to provide for that hour. These settlement provisions are described formulaically in Appendix I.

ISO-Committed Flexible Generators that provide Regulation Service may be eligible to receive a Day-Ahead Bid Production Cost Guarantee payment as described in Section 4 of this manual.

No Regulation Service payments are made to any Supplier providing Regulation Service in excess of the amount of Regulation Service scheduled by the NYISO in the Day-Ahead Market, except to the extent that a Supplier is directed to provide the excess amount by the NYISO.

5.2.2. Regulation Service Settlements – Real-Time Markets

When the Supplier's real-time Regulation Service schedule is less than its Day-Ahead Regulation Service schedule, the Supplier is charged for the imbalance equal to the product of: (i) the Real-Time Regulation Capacity Market Price and (ii) the difference between the Generator's Day-Ahead Regulation Capacity schedule and its real-time Regulation Capacity schedule. When the Supplier's real-time Regulation Service schedule is greater than its Day-Ahead Regulation Service schedule, including those Suppliers that were not scheduled to provide Regulation Service in the DAM, the Supplier is paid for the additional Regulation Service equal to the product of: (i) the Real-Time Regulation Capacity Market Price and (ii) the difference between the Generator's real-time Regulation Capacity schedule and its Day-Ahead Regulation Capacity schedule. These settlement provisions are described formulaically and illustrated graphically in Appendix I.

Additionally, the NYISO will pay Suppliers with real-time Regulation Capacity schedules a real-time payment for Regulation Movement provided in each interval. The payment amount shall equal the product of: (i) the Real-Time Regulation Movement Market Price in that interval; (ii) the Regulation Movement instructed during the interval; and (iii) the performance factor calculated for the Regulation Service provider in that interval.

The NYISO administers a Performance Tracking System (PTS) to monitor the performance of Generators that provide Regulation service. Payments by the NYISO to each Regulation Service provider are based in part on the Generator's performance with respect to expectations. The PTS is also used to assess a performance charge to all Regulation Service providers with Real-Time Regulation Service schedules and to determine penalties assessed to non-regulating Generators that do not follow their RTD base points, thereby increasing the regulation burden. The PTS processes affecting Regulation Service settlements are described formulaically in Appendix G and referenced by the Regulation Service settlement formulae in Appendix I.

A Supplier that bids on behalf of an ISO-Committed Flexible Regulation Service provider may be eligible to receive a Real-Time Bid Production Cost Guarantee payment as described in Section 4 of this manual. No Regulation Service payments will be made to any Supplier providing Regulation Service in excess of the amount of Regulation Service scheduled by the NYISO in real-time, except to the extent that a Supplier is directed to provide the excess amount by the NYISO.

Whenever a Supplier's real-time Regulation Service schedule is reduced by the NYISO to a level lower than its Day-Ahead schedule for that product, the Supplier's Day-Ahead Margin is protected, after accounting for any margin associated with other products that the Supplier's Resource is scheduled to provide in real-time for that time period. The settlement provisions for Day-Ahead Margin Preservation are described formulaically in Appendix H.

5.2.3. Energy Settlement Rules for Generators Providing Regulation Service

For any interval in which a Generator or Aggregation that is not a Limited Energy Storage Resource or an Aggregation of Limited Energy Storage Resources is providing Regulation Service, it shall receive a settlement payment for Energy consistent with a real-time Energy injection equal to the lower of its actual Energy it provides or its AGC Base Point Signal. Demand Side Resources participating in the NYISO's Demand Side Ancillary Services Program and providing Regulation Service shall not receive a settlement payment for Energy.

Demand Reductions from Aggregations providing Regulation Service are only eligible for payment for Energy when the real-time LBMP, at the Aggregation's Transmission Node, meets or exceeds the Monthly Net Benefit Threshold calculated in accordance with Section 4.5.7 of the Services Tariff for the applicable period. When the Monthly Net Benefit Threshold is satisfied, Aggregations will receive an Energy payment for Demand Reductions equal to the lower of the Demand Reductions' contribution to the actual Energy provided or the Aggregation's AGC Base Point Signal.

For any hour in which a Limited Energy Storage Resource or Aggregation of Limited Energy Storage Resources has injected or withdrawn Energy, pursuant to an ISO schedule to do so, it shall receive a settlement payment (if the amount calculated is positive) or charge (if the amount calculated is negative).

These settlement provisions are described formulaically in Appendix B.

5.2.3.1. Additional Payments/Charges When AGC Base Point Signals Exceed RTD Base Point Signals

For any interval in which a Generator that is providing Regulation Service receives an AGC Base Point

Signal that is higher than its RTD Base Point Signal, it receives or pays a Regulation Revenue Adjustment Payment (RRAP) or Regulation Revenue Adjustment Charge (RRAC). If the Energy Bid Price of the Generator is higher than the LBMP at its location in that interval, the Generator receives a RRAP. Conversely, for any interval in which such a Generator's Energy Bid Price is lower than the LBMP at its location at that interval, the Generator is assessed a RRAC. Demand Side Resources providing Regulation Service and Limited Energy Storage Resources are not eligible for a RRAP and are not liable for a RRAC. These settlement provisions are described formulaically in Appendix I. If the result of the calculation of the formula in Appendix I is positive, the Generator is paid a RRAP. If the result is negative, the Generator is subject to a RRAC.

5.2.3.2. Additional Charges/Payments When AGC Base Point Signals Are Lower than RTD Base Point Signals

For any interval in which a Generator that is providing Regulation Service receives an AGC Base Point Signal that is lower than its RTD Base Point Signal, the Supplier is paid a RRAP or charged a RRAC. If the Energy Bid Price of the Generator is higher than the LBMP at its location in that interval, the Generator is assessed a RRAC. Conversely, for any interval in which the Generator's Energy Bid Price is lower than the LBMP at its location in that interval, the Generator is paid a RRAP. Demand Side Resources providing Regulation Service and Limited Energy Storage Resources are not eligible for a RRAP and are not liable for a RRAC. These settlement provisions are described formulaically in Appendix I of this manual. If the result of the calculation of the formula in Appendix I is positive, then the Generator is paid a RRAP. If it is negative then the Generator is subject to a RRAC.

5.2.4. Charges to Suppliers Not Providing Regulation Service

5.2.4.1. Persistent UnderGeneration Charges

An Energy Supplier, other than those excluded through section 5.2.4.2 below, that is not providing Regulation Service and that persistently operates at a level below its schedule [to provide Energy](#) pays a persistent undergeneration charge to the NYISO, unless its output is greater than or equal to its Penalty Limit for Undergeneration; provided, however, no persistent undergeneration charges apply to a Fixed Block Unit that has reached 70% of its Normal Upper Operating Limit. Persistent undergeneration charges per interval are calculated as the product of (i) the Energy Difference; (ii) the greater of the Day-Ahead Regulation Capacity Market Price and the Real-Time Regulation Capacity Market Price; and (iii) the length of the RTD interval, in seconds, divided by 3,600 seconds. The Energy Difference in MW, referenced above, is determined by subtracting the actual Energy provided by the Supplier from its penalty limit for undergeneration for the dispatch interval. If the Energy Difference is less than or equal to zero, no persistent undergeneration charges apply. These settlement provisions are described formulaically in

Appendix I of this manual.

5.2.4.2. Exemptions

The following types of Generators are not subject to persistent undergeneration charges:

- a. Generators, except for the Generator of a Behind-the-Meter Net Generation Resource, providing Energy under contracts (including PURPA contracts), executed and effective on or before November 18, 1999, in which the power purchaser does not control the operation of the supply source but would be responsible for payment of the persistent undergeneration;
- b. Existing topping turbine Generators and extraction turbine Generators producing electric Energy resulting from the supply of steam to the district steam system in operation on or before November 18, 1999 and/or topping or extraction turbine Generators utilized in replacing or repowering existing steam supplies from such units (in accordance with good engineering and economic design) that cannot follow schedules, up to a maximum total of 533 MW of such units;
- c. Limited Control Run of River Hydro;
- d. Intermittent Power Resources and Aggregations of Intermittent Power Resources that depend on landfill gas as their fuel;
- e. Intermittent Power Resources and Aggregations of Intermittent Power Resources that depend on wind or solar energy as their fuel;
- f. Capacity Limited Resources, Aggregations of Capacity Limited Resources, Energy Limited Resources, and Aggregations of Energy Limited Resources to the extent that their Real-Time Energy injections are equal to or greater than their bid-in upper operating limits but are less than their Real-Time Scheduled Energy Injections, unless the Generator or Resource has bid in that hour as ISO-Committed Flexible or Self-Committed Flexible;
- g. Generators operating in their Start-Up Period or Shutdown Period and, for Generators comprised of a group of generating units at a single location, which grouped generating units are separately committed and dispatched by the NYISO, and for which Energy Injections are measured at a single location, each of the grouped generating units when one of the grouped generating units is operating in its Start-Up or Shut down Period; and
- h. Generators operating during a Testing Period as indicated by the use of Out-of-Merit Code 25 (see list of tests in Appendix C) or new units undergoing startup tests provided they have submitted best effort Bids and received base points.
- i. Energy Storage Resources with schedules to withdraw energy are instead subject to persistent over-withdrawal charges.

For Generators and Resources described in Sections a, b, c, and d above, this exemption shall not apply in an hour if the Generator or Resource has bid in that hour as ISO-Committed Flexible or Self-Committed Flexible.

5.2.4.3. Overgeneration Charges

An Intermittent Power Resource that depends on wind or solar energy as its fuel, for which the NYISO has imposed a Wind and Solar Output Limit that operates at a level above its schedule will pay an overgeneration charge to the NYISO, unless its operation is within a tolerance. Overgeneration charges per interval are calculated as the product of: (i) the Energy Difference; (ii) the greater of the Day-Ahead Regulation Capacity Market Price and the Real-Time Regulation Capacity Market Price; and (iii) the length of the RTD interval, in seconds, divided by 3,600 seconds. The Energy Difference in (MW), referenced

above, is determined by subtracting the RTD Base Point Signal for the dispatch interval plus a tolerance from the actual Energy provided by the Supplier for the dispatch interval. The Energy Difference is set to zero for any Energy Difference that is otherwise negative. The tolerance is equal to 3% of the Supplier's Normal Upper Operating Limit or Emergency Upper Operating Limit, as applicable. These settlement provisions are described formulaically in Appendix I of this manual.

5.2.4.4. Persistent Over-Withdrawal Charges

An Energy Storage Resource, an Aggregation of Energy Storage Resources, or DER Aggregation that includes at least one Withdrawal-Eligible Generator that is (a) scheduled to withdraw Energy, (b) not providing Regulation Services, and (c) persistently withdrawing Energy at a level exceeding its withdrawal schedule, shall pay a persistent over-withdrawal charge to the ISO, unless its operation is within the applicable tolerance described below. These settlement provisions are described formulaically in Appendix I of this manual.

5.3. Operating Reserve Service

5.3.1. DAM Settlement of Operating Reserve

Each Supplier, including Demand Side Resources, that is scheduled Day-Ahead to provide Operating Reserve is paid the product of the applicable Day-Ahead Market Clearing Price for the relevant Operating Reserves product, based on its location and quality (i.e., 10-Minute Synchronous, 10-Minute Non-Synchronous, & 30-Minute) of the Operating Reserves scheduled, and the amount of Operating Reserve that the Supplier is scheduled to provide in each hour. These settlement provisions are described formulaically in Appendix I of this manual.

5.3.2. Other Day-Ahead Payments

ISO-Committed Flexible Generators providing Operating Reserves may be eligible to receive a Day-Ahead Bid Production Cost Guarantee payment as described in Section 4 of this manual. Also ISO-Committed Demand Side Resources providing Operating Reserves may be eligible for a DAM Bid Production Cost Guarantee payment as described in Section 4 of this manual.

5.3.3. Balancing Settlement of Operating Reserve

If a Supplier, including Demand Side Resources, deviates from its Day-Ahead schedule to provide Operating Reserves, including deviations that result from schedule modifications made by the NYISO, the deviation is settled pursuant to the following rules.

5.3.3.1.1. When Real-Time Schedule Is Less than DAM Schedule

When the Supplier's real-time Operating Reserves schedule is less than its Day-Ahead Operating Reserves schedule, the Supplier pays a charge for the imbalance equal to the product of (i) the Real-Time Market Clearing Price for the relevant Operating Reserves product in the relevant location and (ii) the difference between the Supplier's Day-Ahead and real-time Operating Reserves schedules. These settlement provisions are described formulaically in Appendix I of this manual.

5.3.3.1.2. When Real-Time Schedule Exceeds DAM Schedule

When the Supplier's real-time Operating Reserves schedule is greater than its Day-Ahead Operating Reserves schedule, the NYISO pays the Supplier for the imbalance equal to the product of (i) the Real-Time Market Clearing Price for the relevant Operating Reserve product in the relevant location and (ii) the difference between the Supplier's Day-Ahead and real-time Operating Reserves schedules. These settlement provisions are described formulaically in Appendix I of this manual.

5.3.3.2. Other Real-Time Payments

The NYISO pays Generators that are selected to provide Operating Reserves, but are directed to convert to Energy production, or, for Withdrawal-Eligible Generators, to reduce Energy withdrawals in real-time, the applicable Real-Time LBMP for all Energy they are directed to produce in excess of their Day-Ahead schedule. A Supplier that bids on behalf of a Generator that provides Operating Reserves or a Demand Side Resource that provides Operating Reserves may be eligible for a Bid Production Cost Guarantee payment described in Section 4 of this manual.

Any Generator that provides Energy during a large event reserve pickup or a maximum generation event may be eligible for a Real-Time Bid Production Cost Guarantee payment as described in Section 4 of this manual.

Generators or Demand Side Resources providing Operating Reserves may be eligible to receive a Real-Time Bid Production Cost Guarantee payment as described in Section 4 of this manual.

Whenever the NYISO reduces the schedule of a Supplier, including Demand Side Resources, to a level lower than its Day-Ahead schedule for that product, the Supplier's Day-Ahead Margin will be protected after accounting for any margin associated with other products that the Resource is scheduled to provide in real-time for that time period. The NYISO produces a Performance Index for purposes of calculating a Day Ahead Margin Assurance payment for a Demand Side Resource providing Operating Reserves. The Performance Index takes account of the actual Demand Reduction achieved by the Supplier of Operating Reserves following the NYISO's instruction to convert Operating Reserves to Demand Reduction. The Performance Index is a factor with a value between 0.0 and 1.0, inclusive. For each interval in which the

NYISO has not instructed the Demand Side Resource to convert its Operating Reserves to Demand Reduction, the Performance Index will have a value of one. For each interval in which the NYISO has instructed the Demand Side Resource to convert its Operating Reserves to Demand Reduction the Performance Index is calculated as the higher of zero or the lesser of (a) the ratio of the average actual demand reduction over the interval and the average scheduled demand reduction over the interval, plus 0.1 and (b) 1. The settlement provisions for Day Ahead Margin Assurance payments are described formulaically in Appendix H of this manual.

5.3.4. Quick Start Reserves

Suppliers providing Quick Start Reserves receive monthly payments for each block of Generator units that provided Quick Start Reserves in any hour of the previous month, unless the block of Generator units also produced Energy during the hour. If a Quick Start Reserves Supplier fails to have the block of Generator units synchronized at the amount of its Hour-Ahead Energy Bid within fifteen (15) minutes of a remote start-up, the Supplier will be subject to the provisions applicable to Suppliers of 10-Minute Non-Spinning Reserves and 30-Minute Reserves that fail to provide Energy within the time allotted; provided, however, that charges against Quick Start Reserves payments will be based upon the blended rate provided formulaically in Appendix I of this manual.

Any block of Generator units requested for Quick Start Reserves for any portion of an hour will be deemed to have provided Quick Start Reserves for the entire hour unless the block of Generator units also produced Energy during the hour. In addition to payments due to a Supplier of Quick Start Reserves, the Supplier will be eligible to receive payments for Energy, Installed Capacity, Operating Reserves, and other Ancillary Services.

5.4. Black Start Capability Service

5.4.1. Settlements for Generators under the Black Start and System Restoration Services Plans Developed by the NYISO and by Individual Transmission Owners Other Than Consolidated Edison

By May 1st of each year, Generators which were selected to provide Black Start and System Restoration Services under the Black Start and System Restoration Services plans developed by the NYISO and by individual Transmission Owners, except for the Consolidated Edison Transmission District, must provide the following cost information to the NYISO based upon FERC Form No. 1 or equivalent data:

- Capital and fixed operation and maintenance costs associated with only that equipment which provides Black Start and System Restoration Services capability;
- Annual costs associated with training operators in Black Start and System Restoration Services; and

- Annual costs associated with Black Start and System Restoration Services testing in accordance with the NYISO Plan or the plan of an individual Transmission Owner.

Each Generator will be paid on the basis of its costs filed with the NYISO. The daily rate for Black Start and System Restoration Services will be determined by dividing the Generator's annual cost by the number of days in the year from May 1st through April 30th of the following year. Black Start and System Restoration Services settlement provisions are described formulaically in Appendix I of this manual.

Any Generator that is awarded Black Start and System Restoration Services payments and that fails a Black Start and System Restoration Services capability test will forfeit all payments for such services since its last successful test. Payments to that Generator will not resume until the Generator successfully passes the test.

5.4.2. Payments to Generators Providing Black Start and System Restoration Services under the Consolidated Edison Transmission District Plan

5.4.2.1. Generators Identified in the Plan filed November 1, 2012

Generators which were selected to provide Black Start and System Restoration Services under the Consolidated Edison Transmission District Black Start and System Restoration Services plan filed with NYISO as of November 1, 2012 will be compensated in accordance with the following provisions.

5.4.2.1.1. Commitment Groups

The NYISO will, in conjunction with Consolidated Edison and the Suppliers, determine in which one of three groups (“Commitment Groups”) a generating unit committed to provide Restoration Services under the Consolidated Edison Plan prior to November 1, 2012, will be included. The Commitment Groups shall have the following initial commitment periods:

- Commitment Group 1: November 1, 2012 – April 30, 2015
- Commitment Group 2: November 1, 2012 – April 30, 2016
- Commitment Group 3: November 1, 2012 – April 30, 2017

The NYISO will also assign a generating unit that is committed to provide Restoration Services under the Consolidated Edison Plan on or after November 1, 2012, to one of these Commitment Groups.

At the conclusion of each commitment period, a generating unit will begin a new three (3) year commitment period to provide Restoration Services under the Consolidated Edison Plan; provided, however, that the unit will not begin a new commitment period if the Supplier or Consolidated Edison provides the NYISO with notice at least two years prior to the conclusion of the previous commitment period that the unit will no longer be part of the Consolidated Edison Plan following the conclusion of that commitment period.

If a Supplier withdraws a unit that is committed to provide Restoration Services from the ISO's energy and capacity markets, the unit may cease its provision of Restoration Services at the same time without completing its commitment period. However, if the Supplier returns the unit to the NYISO's energy and capacity markets within three years of its withdrawal, the unit will be required to provide Restoration Services for that portion of its commitment period that it had not completed.

5.4.2.1.2. Standard Compensation

Except as set forth below, Generators which were selected to provide Black Start and System Restoration Services under the Black Start and System Restoration Services plans developed by Consolidated Edison Transmission District as of November 1, 2012 will be paid each Billing Period the pro rata share of the sum of the annual payment amounts for the provision of Restoration Services under the Consolidated Edison Plan at each of the Suppliers facilities, as determined for each facility as follows:

By May 1st of each year, the NYISO will calculate the annual Restoration Services payment amount for each Supplier's facility for the compensation period of May 1 of that year through the following April 30; except that the NYISO will calculate by November 1, 2012, the annual Restoration Services payment amount for the initial November 1, 2012, through April 30, 2013, period, using a pro rata adjustment of the annual amounts in Tables A and B of Appendix I for the shortened six-month compensation period, and the ISO shall recalculate the annual Restoration Services payment amount if, during the May 1 through April 30 compensation period, one of the Generator's units withdraws from the Consolidated Edison Plan or fails a Black Start Capability Test.

The annual Restoration Services payment amount for each Supplier's facility shall be equal to the sum of the annual payment amounts, calculated according to the following formula, for: (i) each unit at a Supplier's facility providing Restoration Services under the Consolidated Edison Plan that is the sole user of equipment necessary to black start the unit and is not designated with other units as a group by the NYISO ("Sole Black Start Unit"), and (ii) each group of units at the Supplier's facility providing Restoration Services under the Consolidated Edison Plan that share the equipment necessary to black start the units or are otherwise designated as a group by the NYISO ("Black Start Unit Group"). The NYISO will designate a Supplier's unit as a Sole Black Start Unit or as part of a Black Start Unit Group at the start of the unit's commitment period, and this designation shall not be subject to change for the duration of the unit's commitment period. These settlement provisions are described formulaically in Appendix I of this manual.

5.4.2.1.3. Unit-Specific Compensation

A supplier will be entitled to recover, through the NYISO Services Tariff, the actual, incremental cost of its unit's or units' provision of Restoration Services under the Consolidated Edison Plan. If the Supplier

determines that its actual, incremental cost of providing Restoration Services to the NYISO from its unit(s) exceeds the payment amount determined under Section 5.4.2.1.2 above, the Supplier may follow the steps outlined in Rate Schedule 5 of the Services Tariff for FERC approval of the additional costs. Upon approval by FERC, the NYISO will pay a Supplier, each Billing Period, the pro rata share of the FERC-approved annual rate for its unit(s), except as set forth in Section 5.4.2.1.5 below, as described formulaically in Appendix I of this manual.

5.4.2.1.4. Eligibility for Additional Cost Recovery

The NYISO will reimburse Suppliers for equipment damage if the NYISO reasonably finds: (1) the damage resulted from operating such equipment in response to operational orders from the ISO, or Consolidated Edison, pursuant to the NYISO Tariffs, (2) that reasonably available and customary insurance was not available for the damages incurred, and (3) the damage would not have occurred but for the Supplier's provision of Restoration Services. The burden of making such showings will be upon the Supplier.

The payments for each Billing Period will also include compensation for legitimate, verifiable, and adequately documented costs incurred solely as a result of a Supplier's compliance with NERC critical infrastructure protection ("CIP") reliability standards applicable to the provision of Restoration Services, i.e., a CIP cost that would not have been incurred if it were not providing Restoration Services. The Supplier will provide such invoices to the NYISO, which will review and determine if compensation is appropriate.

5.4.2.1.5. Forfeiture of Payments as a Result of Failed Black Start Capability Tests

If a Supplier's unit fails a Black Start Capability Test, the Supplier will forfeit all Restoration Service payments for that unit from the date of the failed test; except that, if the Generator's unit successfully completes the Black Start Capability Test within thirty days of the failed test, the Supplier will not forfeit its payments. This thirty-day period may be extended if agreed upon by the NYISO, the Supplier, and Consolidated Edison. If the Supplier does not successfully complete its Black Start Capability Test within this thirty day, or extended, period and successfully completes the test at a later date, it will receive its Restoration Services payments only from the date of the later, successful test going forward.

5.4.2.2. Generators Electing to Remain Under the Plan in Effect as of October 1, 2005

Generators that were designated in the Consolidated Edison Black Start and System Restoration Service plan filed with the NYISO as of October 1, 2005 which are also named in the revised Consolidated Edison Black Start and System Restoration Services plan filed with the NYISO as of November 1, 2012 and which requested, by December 3, 2012, to be maintained under the October 1, 2005 plan continue to receive

annual compensation for providing Black Start and System Restoration Services based on the unit type and the level of their interconnection to the New York State Transmission System for the duration of their original commitment period. The annual amounts are paid in twelve equal monthly payments pursuant to the following table:

	Steam Turbine	Gas Turbine
138 KV	\$300,000/yr/unit	\$300,000/yr/site
345 KV	\$350,000/yr/unit	\$350,000/yr/site

These monthly payments will also include compensation for legitimate, verifiable, and adequately documented operator Black Start and System Restoration Service training costs and costs associated with annual tests of Black Start and Restoration Services capability that Generators invoice to the NYISO, subject to the NYISO's independent review. If a Generator fails a Black Start and System Restoration Services capability test, it will be subject to a pro rata reduction in its annual payments based on the elapsed time between the unsuccessful test and a subsequent successful test.

Generators will also be reimbursed for equipment damage that the NYISO reasonably finds: (1) to have resulted from operating such equipment in response to operational orders from the NYISO, or Consolidated Edison, pursuant to the NYISO Services Tariff or the NYISO OATT, (2) that reasonably available and customary insurance was not available for the damages incurred and (3) would not have occurred but for the Generator's provision of Black Start and System Restoration Services. Further, the NYISO will reimburse the owners of the Astoria Station steam units 3, 4 and 5 and Astoria Station gas turbines 4-3 and 4-4 for equipment upgrades that the NYISO reasonably finds are needed to minimize the risk of equipment damage at the Astoria Station site in the Consolidated Edison Transmission District. The burden of making such showings will be upon the owners of the specified Generators. Any such reimbursement will be made available for review by the Commission upon request by a Market Participant.

5.4.2.3. Generators Electing to Switch to the Plan in Effect as of November 1, 2012

Generators that were designated in the Consolidated Edison Black Start and System Restoration Service plan filed with the NYISO as of October 1, 2005 which are also named in the revised Consolidated Edison Black Start and System Restoration Services plan filed with the NYISO as of November 1, 2012 and which did not request, by December 3, 2012, to be maintained under the old plan will be compensated pursuant to the provisions described in section 5.4.2.1 above.

5.4.2.4. Generators Identified after November 1, 2012

After November 1, 2012, Consolidated Edison may designate from time to time additional generating units with Restoration Services capability to be included in the Consolidated Edison Plan, if it determines

that additional Restoration Services are needed. A Supplier's generating unit that is committed to provide Restoration Services under the Consolidated Edison Plan after November 1, 2012, will provide, and be paid for providing, Restoration Services pursuant to the provisions described in section 5.4.2.1 above. In addition, all units commencing commercial operation after November 1, 2012, which provide Restoration Services, will be compensated pursuant to the provisions described in section 5.4.2.1 above.

6. Energy Purchase Settlements

6.1. Energy Settlement – Load Serving Entities (LSEs)

6.1.1. DAM Energy Settlement – LSEs

Each LSE that bids into the Day-Ahead Market and has a schedule accepted by the NYISO to purchase Energy in the Day-Ahead Market will pay the product of: (a) the Day-Ahead hourly Zonal LBMP at each Point of Withdrawal; and (b) the scheduled Energy at each Point of Withdrawal, inclusive of any Energy scheduled as a result of Price Capped Load Bids. In addition, for each Demand Reduction Provider that bids a Demand Reduction into the Day-Ahead Market and is scheduled in SCUC to provide Energy from the Demand Reduction, the LSE providing Energy service to the Demand Side Resource that accounts for the Demand Reduction will be paid the product of: (a) the Day-Ahead hourly LBMP at the applicable Demand Reduction Bus; and (b) the hourly demand reduction scheduled Day-Ahead (in MW).

The LSE DAM Energy settlement is illustrated formulaically in Appendix J of this manual.

6.1.2. Balancing Market Energy Settlement – LSEs

When the Actual Energy Withdrawals¹ by an LSE over an RTD interval exceed the Energy withdrawals scheduled over that RTD interval, the LSE is charged the Real-Time LBMP for Energy equal to the product of: (a) the Real-Time LBMP calculated in that RTD interval for each applicable Load Zone; and (b) the difference between the Actual Energy Withdrawals and the scheduled Energy withdrawals, inclusive of Energy purchases scheduled in the DAM and Energy scheduled through Bilateral Transactions sinking at the LSE's bus, in that Load Zone.

When an LSE's Actual Energy Withdrawals over an RTD interval are less than its Energy withdrawals scheduled Day-Ahead over that RTD interval, the LSE is paid the product of: (a) the Real-Time LBMP calculated in that RTD interval for each applicable Load Zone; and (b) the difference between the scheduled Energy withdrawals, inclusive of Energy purchases scheduled in the DAM and Energy scheduled through Bilateral Transactions sinking at the LSE's bus, and the LSE's Actual Energy Withdrawals in that Load Zone. In addition, a Customer LSE providing Energy service to a Demand Reduction Provider's Demand Side Resource in a Load Zone will be charged the product of: (a) the Real-Time hourly LBMP for that Load Zone; and (b) the actual Demand Reduction at the Demand Reduction Bus in that Load Zone.

When actual Demand Reduction over an hour from a Demand Reduction Provider that is also the LSE providing Energy service to the Demand Side Resource(s) that produced the reduction is less than the

¹ The determination of LSE Actual Energy Withdrawals is described in subsection 3.2.2.1.

Demand Reduction scheduled for that hour, that LSE will pay a Demand Reduction imbalance charge consisting of the product of: (a) the greater of the Day-Ahead LBMP or the Real-Time LBMP for that hour and (b) the difference between the scheduled Demand Reduction and the actual Demand Reduction in that hour.

When actual Demand Reduction over an hour from a Demand Reduction Provider that is not the LSE providing Energy service to the Demand Side Resource(s) that produced the reduction is less than the Demand Reduction scheduled over that hour, then (1) the LSE providing Energy service to the Demand Reduction Provider's Demand Side Resource(s) will pay a Demand Reduction imbalance charge equal to the product of (a) the Day-Ahead LBMP calculated for that hour for the applicable Load bus and (b) the difference between the scheduled Demand Reduction and the actual Demand Reduction at that bus in that hour.

The LSE Balancing Market Energy settlement is illustrated formulaically in Appendix J of this manual.

6.1.3. Energy Storage Resource Retail Settlement – LSEs

When a Load Serving Entity requires an Energy Storage Resource, including an Energy Storage Resource participating in an Aggregation, to pay a retail rate for its charging withdrawals, the ISO shall issue a credit to the affected Customer and assess an offsetting charge to the applicable Load Serving Entity in accordance with Services Tariff Section 7.2.8.

6.2. Energy Settlement – LBMP Energy Exports

6.2.1. DAM Energy Settlement – LBMP Energy Exports

Each Customer that bids into the Day-Ahead Market and has a schedule accepted by the NYISO to purchase Energy in the Day-Ahead Market will pay the product of: (a) the Day-Ahead hourly LBMP for the Proxy Generator Bus Point of Delivery (Withdrawal); and (b) the scheduled Energy at each Proxy Generator Bus Point of Delivery (Withdrawal) for the Export Transaction.

The DAM LBMP Energy Export settlement is illustrated formulaically in Appendix J of this manual.

6.2.2. Balancing Market Settlement – LBMP Energy Exports

Customers are subject to the Real-Time Market settlement for all withdrawals not scheduled on a Day-Ahead basis, including Real-Time deviations from any Bilateral Transaction schedules. Settlements with External Loads are based upon hourly scheduled withdrawals.

When a Customer's Actual Energy Withdrawals over an RTD interval exceed its Energy withdrawals

scheduled Day-Ahead over that RTD interval, the Customer is paid or charged the product of: (a) the Real-Time LBMP calculated in that RTD interval for the Proxy Generator Bus Point of Delivery (Withdrawal) for the Transaction; and (b) the difference between the scheduled Energy withdrawals scheduled in the DAM and Actual Energy Withdrawals scheduled in RTD sinking at the Proxy Generator Bus Point of Delivery (Withdrawal) for the Transaction.

When a Customer's Actual Energy Withdrawals over an RTD interval are less than its Energy withdrawals scheduled Day-Ahead over that RTD interval, the Customer is paid or charged the product of: (a) the Real-Time LBMP calculated in that RTD interval for the Generator Proxy Bus Point of Delivery (Withdrawal) for the Transaction; and (b) the difference between the scheduled Energy withdrawals scheduled in the DAM and Actual Energy Withdrawals scheduled in Real-Time sinking at the Generator Proxy Bus Point of Delivery (Withdrawal) for the Transaction.

The Balancing Market LBMP Energy Export settlement is illustrated formulaically in Appendix J of this manual.

6.2.2.1. Financial Impact Charge for LBMP Energy Export Transactions Failing the NYISO Checkout Process

If an Energy withdrawal at a Proxy Generator Bus scheduled by RTC fails in the NYISO's checkout process, the Supplier or Transmission Customer that was scheduled to make the withdrawal will pay or be paid the energy imbalance charge described above. In addition, if the checkout failure occurred for the reasons within the Supplier's or Transmission Customer's control it will be required to pay the "Financial Impact Charge" described below.

If an Energy withdrawal at a Proxy Generator Bus is determined to have failed for reasons within a Supplier's or Transmission Customer's control, the Financial Impact Charge will equal: (i) the difference computed by subtracting the actual real-time Energy withdrawal from the amount of the Export scheduled by RTC; multiplied by (ii) the product of negative one and the lesser of the congestion component of the Real-Time LBMP for the relevant interval, or zero.

The Financial Impact Charge settlement for LBMP Energy Export Transactions failing the NYISO checkout process is illustrated formulaically in Appendix J of this manual.

6.3. Energy Settlement - Virtual Loads

6.3.1. DAM Energy Settlement - Virtual Loads

Each Customer that submits a Bid for a Virtual Transaction and has a schedule accepted by the NYISO to purchase Energy in the Day-Ahead Market will pay the product of: (a) the Day-Ahead hourly Zonal LBMP at

each Point of Withdrawal; and (b) the scheduled Energy at each Point of Withdrawal.

The DAM Energy settlement for Virtual Load is illustrated formulaically in Appendix J of this manual.

6.3.2. Balancing Market Energy Settlement – Virtual Loads

The Actual Energy Withdrawal in a Load Zone by a Customer scheduled Day-Ahead to purchase Energy in a Virtual Transaction is zero and the Customer will be paid the product of: (1) the Real-Time LBMP calculated in that hour for the applicable Load Zone; and (b) the scheduled Day-Ahead Energy Withdrawal of the Customer for that Hour in that Load Zone.

The Balancing Market Energy settlement for Virtual Load is illustrated formulaically in Appendix J of this manual.

6.4. Energy Settlement – Station Power

Station Power is the energy used by a Generator to operate electrical equipment and for the incidental heating, lighting, air conditioning, and office equipment needs of buildings, or portions thereof, that are: (a) owned by the same entity that owns the Generator; (b) located on the Generator site; and (c) used by the Generator exclusively for the production of Energy and any useful thermal energy associated with the production of Energy. Station Power does not include any Energy: (i) used to power synchronous condensers; (ii) used for pumping at a pumped storage facility or for charging a Limited Energy Storage Resource and Energy Storage Resources when that Energy is stored for later injection back to the grid; or (iii) provided during a Black Start restoration by Generators that provide Black Start Capability Service ; or (iv) used by a Resource in an Aggregation. Station Power may be procured in three ways: Self-Supply, Remote Self-Supply, and Third Party Supply.

Station Power settlements are illustrated by example in Appendix N of this manual.

6.4.1. Self-Supply Station Power

A Generator may self-supply Station Power during any calendar month when either: (i) its net output for that month is positive; or (ii) its net output for that month is negative and the Generator, during the same month, has available at other Generators owned by the same entity that owns the Generator positive net output in an amount at least sufficient to offset fully such negative net output (hereinafter referred to as “remote self-supply of Station Power”). A Generator may not remotely self-supply Station Power from Generators that are owned by its owner’s corporate affiliates.

Self-Supply of Station Service is accomplished by the netting of generation output against station

service load over a monthly period for the same unit or complex of units associated with the same Corporate Entity (CE). Since all netting occurs within the footprint of the generation facility, no charges are assessed.

When a Generator has positive net output for an interval and is delivering Energy into the New York State Power System, it will be paid the Real-Time or Day-Ahead LBMP at its bus, as appropriate, for all of the Energy delivered pursuant to the NYISO Services Tariff. Conversely, when a Generator has negative net output for an interval and is self-supplying Station Power from the New York State Power System as described in Sections 6.4.2, 6.4.3, and Appendix N, herein, it will pay the Real-Time or Day-Ahead Zonal LBMP, as appropriate, for all of the Energy consumed, pursuant to the NYISO Services Tariff. When a Generator self-supplies Station Power during any month the Generator will not incur any charges for Transmission Service.

6.4.2. Third-Party Station Power

In the event that the monthly net of generation output for a CE is negative, then Third-Party Station Power occurred. In addition, some Remote Self-Supply Station Power may have occurred, as well. Third-Party Station Service is determined by computing the remaining station service load after Self-Supplied and Remote Self-Supplied Station Service have been netted against such station service load, over a monthly period for units by the same CE.

For CEs that have a negative monthly net generation, the absolute value of that negative monthly amount, or Third-Party Station Power, is allocated across all units of the CE having net negative outputs for the month, by allocating such Station Power against the units with the largest net negative values first, until all Third-Party Station Power has been allocated.

For each unit having Third-Party Station Power allocations, the wholesale cost of such Third-Party Station Power is determined by multiplying: (i) the hourly integrated Zonal LBMP by (ii) hourly net negative generation value and the unit's allocation of Third-Party Supply and then dividing by the total of all hourly negative values for the month. These costs are aggregated over the month and charged to the respective LSE. The Generator(s) are paid a rebate equivalent to this wholesale cost. This calculation is detailed in Appendix N.

6.4.3. Remote Self-Supply Station Power

Remote Self-Supply of Station Service is accomplished by the netting of remotely located generation output against remaining station service load, after Self-Supplied Station Service has been netted against such station service load, over a monthly period for units by the same CE. Generators having Remote Self-

Supply Station Service are assessed NTAC for all megawatt hours of Self-Supply.

When a Generator remotely self-supplies Station Power, the Generator will, to the extent that Transmission Service is involved, pay for Transmission Service for the quantity of Energy that the Generator remotely self supplies. Such Transmission Service will be provided under Section 3 of the NYISO OATT and will be charged the hourly rate under Schedule 7 (Section 6.7) of the NYISO OATT for firm Point-to-Point Transmission Service, provided however, that the terms and charges under Schedules 1 (Section 6.1) through 3 (Section 6.3), 5 (Section 6.5), 6 (Section 6.6), 8 (Section 6.8), and 9 (Section 6.9) of the NYISO OATT will not apply to such service.

7. Transmission Usage Charge (TUC) and Trading Hub Energy Settlements

7.1. TUC Settlements – Internal Transactions

7.1.1. DAM TUC Settlements – Internal Transactions

As part of the Transmission Usage Charge (TUC) charged to all Transmission Customers whose internal transmission service has been scheduled Day-Ahead, each such Transmission Customer is charged or paid in its TUC the product of (a) the amount of Energy scheduled Day-Ahead to be withdrawn by that Transmission Customer in each hour, in megawatt hours; and (b) the Marginal Losses Component of the Day-Ahead LBMP at the Point of Delivery (i.e., Load Zone in which Energy is scheduled to be withdrawn) for the Transaction, in \$/MWh, minus the Marginal Losses Component of the Day-Ahead LBMP at the internal Generator Bus Point of Receipt (Injection) for the Transaction, in \$/MWh.

In addition, all Transmission Customers scheduling internal transmission service Day-Ahead, will be charged or paid, in their TUC, the product of (a) the difference between the amount of Energy scheduled Day-Ahead to be withdrawn by that Transmission Customer in each hour, in megawatts, and the megawatts of the associated grandfathered transmission right times one hour; and (b) the Congestion Component of the Day-Ahead LBMP at the internal Point of Delivery (i.e., Load Zone in which Energy is scheduled to be withdrawn) for the Transaction in \$/MWh, minus the Congestion Component of the Day-Ahead LBMP at the internal Generator Bus Point of Receipt (Injection) for the Transaction, in \$/MWh, plus the Adjustment to Congestion Relief; provided however the Transmission Customer acknowledged the associated grandfathered transmission right, if any, when scheduling the Transaction Day-Ahead.

The calculation of the Adjustment to Congestion Relief is described in Section 7.5 below.

DAM TUC settlements for Internal Transactions are described formulaically in Appendix K of this manual.

7.1.1.1. DAM Replacement Energy to Support Internal Transactions

If the Internal Bilateral Transaction was scheduled in the Day-Ahead Market, and the Day-Ahead Schedule for the Generator designated as the Supplier of Energy for that Bilateral Transaction called for that Generator to produce less Energy than was scheduled Day-Ahead to be consumed in association with that Transaction, the NYISO will supply the Load with Energy from the Day-Ahead LBMP Market. The Transmission Customer scheduling the Bilateral Transaction will continue to pay the Day-Ahead TUC and in addition, the Generator designated as the Supplier of Energy for the Bilateral Transaction will pay the Day-Ahead LBMP price, at the internal Generator Bus Point of Receipt (Injection) for the Transaction, for

the replacement amount of Energy in (megawatt hours) purchased in the LBMP Market.

DAM Replacement Energy settlements for Generators designated as the Suppliers of Energy for Bilateral Transactions that are scheduled to produce less Energy than is necessary to support the Internal Transactions are described formulaically in Appendix B of this manual.

7.1.2. Balancing Market TUC Settlements – Internal Transactions

As part of the Transmission Usage Charge (TUC) charged to all Transmission Customers whose internal transmission service was scheduled after the determination of the Day-Ahead schedule, or either increased or decreased the amount of the internal transmission service after the determination of the Day-Ahead Transaction schedule, each such Transmission Customer is charged or paid the product of (a) actual Energy Withdrawals by RTD in each hour, minus the amount of Energy scheduled Day-Ahead to be withdrawn by that Transmission Customer in that hour, in megawatt hours; and (b) the Marginal Losses Component of the Real-Time LBMP at the Point of Delivery (i.e., Load Zone in which Energy is scheduled to be withdrawn) for the Transaction, in \$/MWh, minus the Marginal Losses Component of the Real-Time LBMP at the internal Generator Bus Point of Receipt (Injection) for the Transaction, in \$/MWh.

Also as part of the TUC charged to all Transmission Customers whose internal transmission service was scheduled after the determination of the Day-Ahead schedule, or either increased or decreased the amount of the internal transmission service after the determination of the Day-Ahead Transaction schedule, each such Transmission Customer is charged or paid the product of (a) actual Energy Withdrawals by RTD in each hour, minus the amount of Energy scheduled Day-Ahead to be withdrawn by that Transmission Customer in that hour, in megawatt hours; and (b) the Congestion Component of the Real-Time LBMP at the Point of Delivery (i.e., Load Zone in which Energy is scheduled to be withdrawn) for the Transaction, in \$/MWh, minus the Congestion Component of the Real-Time LBMP at the internal Generator Bus Point of Receipt (Injection) for the Transaction, in \$/MWh.

Balancing Market TUC settlements for Internal Transactions are described formulaically in Appendix K of this manual.

7.1.2.1. Real-Time Replacement Energy to Support Internal Transactions

If the Generator designated as the Supplier of Energy for that Bilateral Transaction is dispatched in real-time to produce less Energy than necessary to supply the Transaction, the NYISO will supply the Load with Energy from the Real-Time LBMP Market. The Transmission Customer scheduling the Bilateral Transaction will continue to pay the respective TUC and in addition, the Generator designated as the Supplier of Energy for the Bilateral Transaction will pay the Real-Time LBMP price, at the internal

Generator Bus Point of Receipt (Injection) for the Transaction, for any additional Replacement Energy (in megawatt hours) necessary to supply the Transaction.

Real-Time Replacement Energy settlements for Generators designated as the Suppliers of Energy for that Bilateral Transactions that are dispatched in real-time to produce less Energy than necessary to supply the Transactions are described formulaically in Appendix B of this manual.

7.1.2.2. Transactions Supplied by Certain Resources Pursuant to PURPA Contracts or Supplying Steam to NYC

The amount of Transmission Service scheduled hour-ahead in the RTC for Transactions supplied by one of the following Generators will retroactively be set equal to that Generator's actual output in each RTD interval: (i) Generators providing Energy under contracts executed and effective on or before November 18, 1999 (including PURPA contracts) in which the power purchaser does not control the operation of the supply source but would be responsible for penalties for being off-schedule; and (ii) Existing topping turbine Generators and extraction turbine Generators producing electric Energy resulting from the supply of steam to the district steam system located in New York City (LBMP Zone J) in operation on or before November 18, 1999 and/or topping or extraction turbine Generators utilized in replacing or repowering existing steam supplies from such units (in accordance with good engineering and economic design) that cannot follow schedules, up to a maximum total of 499 MW of such units. This procedure will not apply for those hours the Generator supplying that Transaction has bid in a manner that indicates it is available to provide Regulation Service or Operating Reserves.

7.2. TUC Settlements – Import Bilateral Transactions

7.2.1. DAM TUC Settlements – Import Bilateral Transactions

As part of the Transmission Usage Charge (TUC) charged to all Transmission Customers whose import transmission service has been scheduled Day-Ahead, each such Transmission Customer is charged or paid in its TUC the product of (a) the amount of Energy scheduled Day-Ahead to be withdrawn by that Transmission Customer in each hour, in megawatt hours; and (b) the Marginal Losses Component of the Day-Ahead LBMP at the Point of Delivery (i.e., Load Zone in which Energy is scheduled to be withdrawn) for the Transaction, in \$/MWh, minus the Marginal Losses Component of the Day-Ahead LBMP at the Point of Receipt (i.e., Proxy Generator Bus in which Energy is scheduled to be injected into the NYCA) for the Transaction, in \$/MWh.

In addition, all Transmission Customers scheduling Import Transactions Day-Ahead, will be charged or paid, in their TUC, the product of (a) the difference between the amount of Energy scheduled Day-Ahead to be withdrawn by that Transmission Customer in each hour, in megawatts, and the megawatts of the

associated Grandfathered Transmission Rights times one hour; and (b) the Congestion Component of the Day-Ahead LBMP at the Point of Delivery (i.e., Load Zone in which Energy is scheduled to be withdrawn) for the Transaction, in \$/MWh, minus the Congestion Component of the Day-Ahead LBMP at the Point of Receipt (i.e., Proxy Generator Bus in which Energy is scheduled to be injected into the NYCA) for the Transaction, in \$/MWh, plus the Adjustment to Congestion Relief; provided however the Transmission Customer acknowledged the associated Grandfathered Right, if any, when scheduling the transaction Day-Ahead.

The calculation of the Adjustment to Congestion Relief is described in Section 7.5 below.

DAM TUC settlements for Import Bilateral Transactions are described formulaically in Appendix K of this manual.

7.2.1.1. DAM Replacement Energy for Curtailed Imports

If the Import Bilateral Transaction was scheduled in the Day-Ahead Market at an amount less than what was bid for that Bilateral Transaction, the NYISO will supply the Load with Energy from the Day-Ahead LBMP Market. The Transmission Customer scheduling the Bilateral Transaction will continue to pay the Day-Ahead TUC and in addition, the Transmission Customer for the Bilateral Transaction, if it takes service under the NYISO Market Administration and Control Area Services Tariff (Services Tariff), will pay the Day-Ahead LBMP price, at the Proxy Generator Bus Point of Receipt (Injection) for the Transaction, for the replacement amount of Energy in (megawatt hours) purchased in the LBMP Market. If the Transmission Customer for the Bilateral Transaction does not take service under the Services Tariff, it will pay the greater of 150 percent of the Day-Ahead LBMP at the Proxy Generator Bus Point of Receipt (Injection) for the Transaction or \$100/MWh, for the replacement amount of Energy.

DAM Replacement Energy settlements for Curtailed Import Transactions are described formulaically in Appendix K of this manual.

7.2.2. Balancing Market TUC Settlements – Import Bilateral Transactions

As part of the Transmission Usage Charge (TUC) charged to all Transmission Customers whose import transmission service was scheduled after the determination of the Day-Ahead schedule, or either increased or decreased the amount of the Import Transmission Service after the determination of the Day-Ahead Transaction schedule, each such Transmission Customer is charged or paid the product of (a) Actual Energy Withdrawals by RTD in each hour, minus the amount of Energy scheduled Day-Ahead to be withdrawn by that Transmission Customer in that hour, in megawatt hours; and (b) the Marginal Losses Component of the Real-Time LBMP at the Point of Delivery (i.e., Load Zone in which Energy is scheduled to

be withdrawn) for the Transaction, in \$/MWh, minus the Marginal Losses Component of the Real-Time LBMP at the Point of Receipt (i.e., the Proxy Generator Bus in which Energy is scheduled to be injected into the NYCA) for the Transaction, in \$/MWh.

Also as part of the TUC charged to all Transmission Customers whose Import Transmission Service was scheduled after the determination of the Day-Ahead schedule, or either increased or decreased the amount of the Import Transmission Service after the determination of the Day-Ahead Transaction schedule, each such Transmission Customer is charged or paid the product of (a) Actual Energy Withdrawals by RTD in each hour, minus the amount of Energy scheduled Day-Ahead to be withdrawn by that Transmission Customer in that hour, in megawatt hours; and (b) the Congestion Component of the Real-Time LBMP at the Point of Delivery (i.e., Load Zone in which Energy is scheduled to be withdrawn) for the Transaction, in \$/MWh, minus the Congestion Component of the Real-Time LBMP at the Point of Receipt (i.e., the Proxy Generator Bus in which Energy is scheduled to be injected into the NYCA) for the Transaction, in \$/MWh.

Balancing Market TUC settlements for Import Bilateral Transactions are described formulaically in Appendix K of this manual.

7.2.2.1. Real-Time Replacement Energy for Curtailed Imports

If the Import Bilateral Transaction was scheduled at an amount less than what was bid for that Bilateral Transaction, the NYISO will supply the Load with Energy from the Real-Time LBMP Market. The Transmission Customer scheduling the Bilateral Transaction will continue to pay the respective TUC and in addition, the Transmission Customer for the Bilateral Transaction, if it takes service under the NYISO Services Tariff, will pay the Real-Time LBMP price, at the Proxy Generator Bus Point of Receipt (Injection) for the Transaction, for the replacement amount of Energy in (megawatt hours) purchased in the LBMP Market. If the Transmission Customer for the Bilateral Transaction does not take service under the Services Tariff, it will pay the greater of 150 percent of the Real-Time LBMP at the Proxy Generator Bus Point of Receipt (Injection) for the Transaction or \$100/MWh, for the replacement amount of Energy.

If the Energy injections scheduled by RTC at a Proxy Generator Bus are Curtailed at the request of the NYISO, then the Supplier of the Transmission Customer whose Transaction is Curtailed, in addition to paying the charge for Replacement Energy necessary to serve the Load, will be paid the product (if positive) of: (a) the Real-Time LBMP at the Proxy Generator Bus minus the higher of the Real-Time Bid price and zero; and (b) the DAM scheduled Energy injection minus the actual Energy injections at that Proxy Generator Bus for the dispatch hour. An Internal Generator supplying Energy for such Transmission Service that is Reduced or Curtailed may sell its excess Energy in the Real-Time LBMP Market.

Real-Time Replacement Energy settlements for Curtailed Import Transactions are described

formulaically in Appendix K of this manual.

7.2.2.2. Financial Impact Charge for TUC Imports Failing the NYISO Checkout Process

If an Energy injection scheduled by RTC at a Proxy Generator Bus fails in the NYISO's checkout process the Supplier or Transmission Customer that was scheduled to make the injection will pay the Energy Imbalance Charge described above. In addition, if the checkout failure occurred for reasons within the Supplier's or Transmission Customer's control it will be required to pay a "Financial Impact Charge." If an Energy injection at a Proxy Generator Bus is determined to have failed for reasons within a Supplier's or Transmission Customer's control, the Financial Impact Charge will equal: (i) the difference computed by subtracting the actual real-time Energy injection from the amount of the Import scheduled by RTC; multiplied by (ii) the greater of the congestion component of the Real-Time LBMP for the relevant interval, or zero.

All Financial Impact Charges collected by the NYISO will be used to reduce the charges assessed under Rate Schedule 1 of the NYISO Services Tariff. In the event that the Energy injections scheduled by RTC at a Proxy Generator Bus are Curtailed at the request of the NYISO then the Supplier or Transmission Customer that is subjected to the Curtailment, in addition to the charge for Energy Imbalance will be paid the product (if positive) of: (a) the Real-Time LBMP at the Proxy Generator Bus minus the higher of its real-time Bid and zero; and (b) the DAM scheduled Energy injections minus the actual Energy injections at that Proxy Generator Bus for the dispatch hour.

Settlements for Financial Impact Charges for Import Transactions failing the NYISO checkout process are described formulaically in Appendix K of this manual.

7.3. TUC Settlements – Export Bilateral Transactions

7.3.1. DAM TUC Settlements – Export Bilateral Transactions

As part of the Transmission Usage Charge (TUC) charged to all Transmission Customers whose Export Transmission Service has been scheduled Day-Ahead, each such Transmission Customer is charged or paid in its TUC the product of (a) the amount of Energy scheduled Day-Ahead to be withdrawn by that Transmission Customer in each hour for the Transaction, in megawatt hours; and (b) the Marginal Losses Component of the Day-Ahead LBMP at the Point of Delivery (i.e., the Proxy Generator Bus where Energy is scheduled to be withdrawn from the NYCA) for the Transaction, in \$/MWh, minus the Marginal Losses Component of the Day-Ahead LBMP at the internal Generator Bus Point of Receipt (Injection) for the Transaction, in \$/MWh.

In addition, all Transmission Customers scheduling export transmission service Day-Ahead, will be charged or paid, in their TUC, the product of (a) the difference between the amount of Energy scheduled Day-Ahead to be withdrawn by that Transmission Customer in each hour for the Transaction, in megawatts, and the megawatts of the associated Grandfathered Transmission Rights times one hour; and (b) the Congestion Component of the Day-Ahead LBMP at the Point of Delivery (i.e., the Proxy Generator Bus where Energy is scheduled to be withdrawn from the NYCA) for the Transaction, in \$/MWh, minus the Congestion Component of the Day-Ahead LBMP at the internal Generator Bus Point of Receipt (Injection) for the Transaction, in \$/MWh, plus the Adjustment to Congestion Relief; provided however the Transmission Customer acknowledged the associated Grandfathered Transmission Right, if any, when scheduling the Transaction Day-Ahead.

The calculation of the Adjustment to Congestion Relief is described in Section 7.5.

DAM TUC settlements for Export Bilateral Transactions are described formulaically in Appendix K of this manual.

7.3.1.1. Suppliers Scheduled Day-Ahead below Export Bilateral Contract Commitments

If the Generator designated as the Supplier of Energy for the Bilateral Transaction is scheduled to produce less Energy than is necessary to supply the Transaction, the NYISO will supply the Transmission Customer with Energy from the Day-Ahead LBMP Market. The Transmission Customer scheduling the Bilateral Transaction will continue to pay the respective TUC and in addition, the Supplier of Energy for the Bilateral Transaction will pay the Day-Ahead LBMP price, at the internal Generator Bus Point of Receipt (Injection) for the Transaction, for any additional Replacement Energy (in megawatt hours) necessary to supply the Transaction.

DAM settlements for Generators designated as the Suppliers of Energy for a Bilateral Transaction that are scheduled to produce less Energy than is necessary to supply the Transaction Export Bilateral Transactions are described formulaically in Appendix B of this manual.

7.3.2. Balancing Market TUC Settlements – Export Bilateral Transactions

As part of the Transmission Usage Charge (TUC) charged to all Transmission Customers whose Export Transmission Service was scheduled after the determination of the Day-Ahead schedule, or either increased or decreased the amount of the Export Transmission Service after the determination of the Day-Ahead Transaction schedule, each such Transmission Customer is charged or paid the product of (a) actual Energy Withdrawals by RTD in each hour, minus the amount of Energy scheduled Day-Ahead to be withdrawn by that Transmission Customer in that hour, in megawatt hours; and (b) the Marginal Losses

Component of the Real-Time LBMP at the Point of Delivery (i.e., the external bus where Energy is scheduled to be withdrawn from the NYCA) for the Transaction, in \$/MWh, minus the Marginal Losses Component of the Real-Time LBMP at the internal Generator Bus Point of Receipt (Injection) for the Transaction, in \$/MWh.

Also as part of the TUC charged to all Transmission Customers whose export transmission service was scheduled after the determination of the Day-Ahead schedule, or either increased or decreased the amount of the export transmission service after the determination of the Day-Ahead Transaction schedule, each such Transmission Customer is charged or paid the product of (a) actual Energy Withdrawals by RTD in each hour, minus the amount of Energy scheduled Day-Ahead to be withdrawn by that Transmission Customer in that hour, in megawatt hours; and (b) the Congestion Component of the Real-Time LBMP at the Point of Delivery (i.e., the external bus where Energy is scheduled to be withdrawn from the NYCA) for the Transaction, minus the Congestion Component of the Real-Time LBMP at the internal Generator Bus Point of Receipt (Injection) for the Transaction, in \$/MWh.

Balancing Market TUC settlements for Export Bilateral Transactions are described formulaically in Appendix K of this manual.

7.3.2.1. Suppliers Scheduled In Real-Time below Export Bilateral Contract Commitments

If the Generator designated as the Supplier of Energy for that Export Bilateral Transaction is dispatched to produce less Energy than is necessary to supply the Transaction, the NYISO will supply the Transmission Customer with Energy from the Real-Time LBMP Market. The Transmission Customer scheduling the Bilateral Transaction will continue to pay the respective TUC and in addition, the Supplier of Energy for the Bilateral Transaction will pay the Real-Time LBMP price, at the internal Generator Bus Point of Receipt (Injection) for the Transaction, for any additional replacement Energy (in megawatt hours) necessary to supply the Transaction.

Real-Time Market settlements for Generators designated as the Suppliers of Energy for a Bilateral Transaction that are scheduled to produce less Energy than is necessary to supply the Transaction Export Bilateral Transactions are described formulaically in Appendix B of this manual.

7.3.2.2. Financial Impact Charge for Export Transactions Failing the NYISO Checkout Process

If an Energy withdrawal at a Proxy Generator Bus scheduled by RTC fails in the NYISO's checkout process, the Supplier or Transmission Customer that was scheduled to make the withdrawal will pay or be paid the Energy Imbalance Charge described above. In addition, if the checkout failure occurred for the reasons within the Supplier's or Transmission Customer's control it will be required to pay the "Financial

Impact Charge” described below.

If an Energy withdrawal at a Proxy Generator Bus is determined to have failed for reasons within a Supplier’s or Transmission Customer’s control, the Financial Impact Charge will equal: (i) the difference computed by subtracting the actual real-time Energy withdrawal from the amount of the Export scheduled by RTC; multiplied by (ii) the product of negative one and the lesser of the Real-Time Market Congestion Component of the LBMP in the relevant interval, or zero.

Settlements for Financial Impact Charges for Export Transactions failing the NYISO checkout process are described formulaically in Appendix K of this manual.

7.4. TUC Settlements – Wheel Through Transactions

7.4.1. DAM TUC Settlements – Wheel Through Transactions

As part of the Transmission Usage Charge (TUC) charged to all Transmission Customers who schedule Day-Ahead Wheels Through, each such Transmission Customer is charged or paid in its TUC the product of (a) the Transmission Customer’s Day-Ahead scheduled Wheels Through in each hour, in megawatt hours; and (b) the Marginal Losses Component of the Day-Ahead LBMP at the Point of Delivery (i.e., the Proxy Generator Bus where Energy is scheduled to be withdrawn from the NYCA) for the Transaction, in \$/MWh, minus the Marginal Losses Component of the Day-Ahead LBMP at the Point of Receipt (i.e., the Proxy Generator Bus where Energy is scheduled to be injected into the NYCA) for the Transaction, in \$/MWh.

In addition, all Transmission Customers scheduling Wheels Through Day-Ahead, will be charged or paid, in their TUC, the product of (a) the difference between the Transmission Customer’s Day-Ahead scheduled Wheels Through in each hour, in megawatts and the megawatts of the associated Grandfathered Transmission Rights times one hour; and (b) the Congestion Component of the Day-Ahead LBMP at the Point of Delivery (i.e., the Proxy Generator Bus where Energy is scheduled to be withdrawn from the NYCA) for the Transaction, in \$/MWh, minus the Congestion Component of the Day-Ahead LBMP at the Point of Receipt (i.e., the Proxy Generator Bus where Energy is scheduled to be injected into the NYCA) for the Transaction, in \$/MWh provided however the Transmission Customer acknowledged the associated Grandfathered Transmission Right, if any, when scheduling the Transaction Day-Ahead.

DAM TUC settlements for Wheels Through are described formulaically in Appendix K of this manual.

7.4.2. Balancing Market TUC Settlements – Wheel Through Transactions

As part of the Transmission Usage Charge (TUC) charged to all Transmission Customers who schedule Wheels Through after the determination of the Day-Ahead schedule, or who either increased or decreased

the amount of the Wheel Through Transmission Service after the determination of the Day-Ahead Transaction schedule, each such Transmission Customer is charged or paid the product of (a) actual Energy Withdrawals by RTD in each hour, minus the amount of Energy scheduled Day-Ahead to be withdrawn by that Transmission Customer in that hour, in megawatt hours; and (b) the Marginal Losses Component of the Real-Time LBMP at the Point of Delivery (i.e., the external bus where Energy is scheduled to be withdrawn from the NYCA) for the Transaction, in \$/MWh, minus the Marginal Losses Component of the Real-Time LBMP at the Point of Receipt (i.e., the Proxy Generator Bus where Energy is scheduled to be injected into NYCA) for the Transaction, in \$/MWh.

Also as part of the TUC charged to all Transmission Customers who schedule Wheels Through after the determination of the Day-Ahead schedule, or who either increased or decreased the amount of the Wheel Through transmission service after the determination of the Day-Ahead Transaction schedule, each such Transmission Customer is charged or paid the product of (a) actual Energy Withdrawals by RTD in each hour, minus the amount of Energy scheduled Day-Ahead to be withdrawn by that Transmission Customer in that hour, in megawatt hours; and (b) the Congestion Component of the Real-Time LBMP at the Point of Delivery (i.e., the external bus where Energy is scheduled to be withdrawn from the NYCA) for the Transaction, in \$/MWh, minus the Congestion Component of the Real-Time LBMP at the Point of Receipt (i.e., the Proxy Generator Bus where Energy is scheduled to be injected into NYCA) for the Transaction, in \$/MWh.

Balancing Market TUC settlements for Wheel Through Bilateral Transactions are described formulaically in Appendix K of this manual.

7.4.2.1. Financial Impact Charge for Wheel Through Transactions Failing the NYISO Checkout Process

If a Wheel Through Transaction scheduled by RTC at a Proxy Generator Bus fails in the NYISO's checkout process and the checkout failure occurred for reasons within the Supplier's or Transmission Customer's control, the Supplier or Transmission Customer will be required to pay a "Financial Impact Charge."

If a Wheel Through Transaction is determined to have failed for reasons within a Supplier's or Transmission Customer's control, the Financial Impact Charge will equal the sum of: (a) the Financial Impact Charge associated with the failed checkout at the Point of Injection and (b) the Financial Impact Charge associated with failed checkout at the Point of Withdrawal.

The Energy injection portion of Financial Impact Charge will equal: (i) the difference computed by subtracting the actual real-time Energy injection from the amount of the Import scheduled by RTC; multiplied by (ii) the greater of the congestion component of the Real-Time LBMP for the relevant interval,

or zero.

The Energy withdrawal portion of the Financial Impact Charge will equal: (i) the difference computed by subtracting the actual real-time Energy withdrawal from the amount of the Export scheduled by RTC; multiplied by (ii) the product of negative one and the lesser of the congestion component of the Real-Time LBMP for the relevant interval, or zero.

Settlements for Financial Impact Charges for Wheel Through Transactions failing the NYISO checkout process are described formulaically in Appendix K of this manual.

7.5. Adjustment to Congestion Relief for Transactions Claiming Grandfathered Transmission Rights

A grandfathered transmission right (GTR) protects the owner from paying for some or the entire congestion component of the TUC over a specified path. The GTR will indicate a Point of Receipt and Point of Withdrawal. The Point of Receipt can be either a specific Generator or a Zone.

The GTR is considered to match a Bilateral Transaction under two specific scenarios. First, if the Point of Receipt of the GTR is a generator and the Point of Receipt of the Bilateral Transaction is that same generator, the Point of Delivery of the Bilateral Transaction must be either the same zone as the GTR Point of Delivery or to a load bus within that zone for them to match. Second, if the Point of Receipt of the GTR is a zone and the Point of Receipt of the Bilateral Transaction is a generator within that zone, the Point of Delivery of the Bilateral Transaction must be either the same zone as the GTR Point of Delivery or a load bus within that zone for them to match. However, in this second case, because the pricing points for the Point of Receipt will be different, an adjustment must be made.

The Congestion Cost for a Bilateral Transaction involving GTRs is equal to the product of: (i) the total MWs associated with the Bilateral Transaction less the MWs associated with the GTR and (ii) the LBMP congestion cost on the transaction. If the Point of Receipt of the GTR is a Zone rather than a Generator Bus an adjustment is added to the formula above to reflect the differences in the Congestion Cost between the Bilateral Transaction and the GTR due to any differences in their Points of Receipt. The specific calculation varies depending on the relationship between the LBMP congestion cost of the Bilateral Transaction and the LBMP congestion cost of the GTR. This settlement and the treatment of the seven possible relationships are described formulaically in Appendix K.

7.6. NYPA Transmission Adjustment Charge (NTAC)

7.6.1. Exports and Wheels Through

Transmission Customers scheduling Export or Wheel Through Transactions pay an NTAC based on

their real-time Transaction schedules. The NTAC charge will not apply to Exports and Wheels Through (a) scheduled with the NYISO to destinations (i.e., Points of Delivery) within the New England Control Area, provided that the conditions listed in Section 2.7.2.1.4 of the NYISO Open Access Transmission Tariff (OATT) are satisfied or (b) scheduled quantities that are Curtailed by the NYISO.

The NTAC charged to Transmission Customers scheduling Export or Wheel Through Transactions is the product of (a) the monthly NTAC Rate and (b) the real-time, hourly Energy scheduled as Exports or Wheels Through in each hour, in megawatt hours.

7.6.2. Imports, Internal Bilaterals, and Loads within the NYCA

Each LSE serving Load in the NYCA is charged an NTAC based on the LSE's Actual Energy Withdrawals. The NTAC charged to LSEs is the product of (a) the monthly NTAC Rate and (b) the LSEs' real-time, hourly Actual Energy Withdrawals, in megawatt hours.

7.6.3. Energy Storage Resource

Energy Storage Resource in the NYCA is charged an NTAC based on the Energy Storage Resource's Actual Energy Withdrawals when the Energy Storage Resource is not providing a service. An Aggregation containing one or more Energy Storage Resources will pay an NTAC to the ISO when (i) the Aggregation is not providing a service, and (ii) the sum of the Aggregation's Energy injections and Demand Reductions, less the Aggregation's Energy withdrawals, is negative. An Energy Storage Resource, and an Aggregation containing one or more Energy Storage Resources, is providing a "service" when it is withdrawing Energy if it also: (1) receives a Real-Time Market schedule for Operating Reserves; or (2) receives a Real-Time Market schedule for Regulation Service; or (3) is a qualified Supplier of Voltage Support Service to the ISO in accordance with Section 15.2 of the ISO Services Tariff; or (4) is dispatched by the ISO as Out-of-Merit to meet NYCA or local system reliability in the same hour.

An Energy Storage Resource that participates as a Co-located Storage Resource will only pay an NTAC for net Actual Energy Withdrawals by the combined Co-located Storage Resources. An Energy Storage Resource that participates as a Co-located Storage Resource will not pay an NTAC when it receives charging Energy from its co-located Intermittent Power Resource behind the Co-located Storage Resources' shared Point of Injection/Point of Withdrawal.

7.7. Trading Hub Energy Settlements

7.7.1. Day-Ahead Market Energy Settlements at Trading Hub Point of Injection Buses

Each Trading Hub Energy Owner who bids a Bilateral Transaction into the Day-Ahead Market with a Trading Hub as its Point of Injection (Source) and has its schedule accepted by the NYISO will be charged the product of: (a) the Day-Ahead hourly zonal LBMP for the Load Zone associated with that Trading Hub; and (b) the Bilateral Transaction scheduled megawatts.

Day-Ahead Market Energy Settlements at Trading Hub Point of Injection Buses are described formulaically in Appendix K.

7.7.2. Real-Time Market Energy Settlements at Trading Hub Point of Injection Buses

Each Trading Hub Energy Owner who bids a Bilateral Transaction into the Real-Time Market with a Trading Hub as its Point of Injection (Source) and has its schedule accepted by the NYISO will be charged the product of: (a) the hourly integrated Real-Time LBMP for the Load Zone associated with that Trading Hub; and (b) the Bilateral Transaction scheduled megawatts.

Real-Time Market Energy Settlements at Trading Hub Point of Injection Buses are described formulaically in Appendix K of this manual.

7.7.3. Day-Ahead Market Energy Settlements at Trading Hub Point of Withdrawal Buses

Each Trading Hub Energy Owner who bids a Bilateral Transaction into the Day-Ahead Market with a Trading Hub as its Point of Withdrawal (Sink) and has its schedule accepted by the NYISO will be paid the product of: (a) the Day-Ahead hourly zonal LBMP for the Load Zone associated with that Trading Hub; and (b) the Bilateral Transaction scheduled megawatts.

Day-Ahead Market Energy Settlements at Trading Hub Point of Withdrawal Buses are described formulaically in Appendix K of this manual.

7.7.4. Real-Time Market Energy Settlements at Trading Hub Point of Withdrawal Buses

Each Trading Hub Energy Owner who bids a Bilateral Transaction into the Real-Time Market with a Trading Hub as its Point of Withdrawal (Sink) and has its schedule accepted by the NYISO will be paid the product of: (a) the hourly integrated Real-Time LBMP for the Load Zone associated with that Trading Hub; and (b) the Bilateral Transaction scheduled megawatts.

Real-Time Market Energy Settlements at Trading Hub Point of Withdrawal Buses are described formulaically in Appendix K of this manual.

7.8. Export and Wheel Through Transmission Service Charge

7.8.1. External Transaction TSC MWh Reporting

Export and Wheel through transaction customers will pay a TSC charge directly to the Transmission Owner as described in Appendix A. These withdrawals will be calculated by the NYISO and reported to both the generator and Transmission Owner in their respective settlement statements and reports.

8. Ancillary Services and Other Charges

8.1. NYISO Annual Budget Charge and Other Non-Budget Rate Schedule 1 Charges and Payments (OATT)

For purposes of Section 8.1 of this manual and the related provisions in Appendix M of this manual, the term *Transmission Customer* refers to both a Transmission Customer taking service under the *NYISO OATT* and a Customer taking service under the *NYISO Services Tariff*.

The NYISO will bill each Transmission Customer on a monthly basis under Rate Schedule 1 to recover the NYISO's annual budgeted costs as set forth in Section 8.1.1 of this manual.

The NYISO will separately bill each Transmission Customer under Rate Schedule 1 for certain other charges and payments not related to the NYISO annual budget charge. Specifically, the NYISO will bill each Transmission Customer on a quarterly basis to recover NERC and NPCC charges as set forth in Section 8.1.2 of this manual and on a monthly basis to recover FERC charges. The NYISO will also bill each Transmission Customer on a monthly basis to recover the following costs or allocate the following received payments under Rate Schedule 1:

- a. Bad debt loss charges as set forth in Section 8.1.4;
- b. Working Capital Fund charges as set forth in Section 8.1.5;
- c. Non-NYISO facilities payment charges as set forth in Section 8.1.6;
- d. Charges to recover costs for payments made to Suppliers pursuant to incremental cost recovery for units that responded to Local Reliability Rules G.2 and G.3 as set forth in Section 8.1.7;
- e. Charges to recover and payments to allocate residual costs as set forth in Section 8.1.8;
- f. Charges for Special Case Resources and Curtailment Service Providers called to meet reliability needs as set forth in Section 8.1.9;
- g. Charges to recover DAMAP costs as set forth in Section 8.1.10;
- h. Charges to recover Import Curtailment Guarantee Payment costs as set forth in Section 8.1.11;
- i. Charges to recover Bid Production Cost Guarantee payment costs as set forth in Section 8.1.12;
- j. Charges to recover and payments to allocate settlements of disputes as set forth in Section 8.1.13; and
- k. Payments to allocate financial penalties collected by the NYISO as set forth in Section 8.1.14; and
- l. Charges to recover FERC Fee charges as set forth in Section 8.1.15.

The calculation methodologies for the NYISO annual budget charge and other non-budget Rate Schedule 1 charges and payments are illustrated formulaically in Appendix M of this manual.

8.1.1. NYISO Annual Budget Charge

The NYISO will charge, and each Transmission Customer will pay, a charge for the NYISO's recovery of

its annual budgeted costs. The NYISO annual budgeted costs that are recoverable through Rate Schedule 1 are set forth in Section 8.1.2 of this manual. The NYISO will calculate the charge for the recovery of these NYISO annual budgeted costs from each Transmission Customer on the basis of its participation in physical market activity as illustrated formulaically in Appendix M of this manual. The NYISO will also calculate this charge for each Transmission Customer on the basis of its participation in non-physical market activity (which includes engaging in Virtual Transactions or purchasing Transmission Congestion Contracts), the Special Case Resource program, and the Emergency Demand Response program as illustrated formulaically in Appendix M of this manual. The NYISO will use the revenue collected from Transmission Customers based on their participation in non-physical market activity, the Special Case Resource program, and the Emergency Demand Response program to fully recover any of its annual budgeted costs for the immediately preceding calendar year that it has not already recovered from Transmission Customers based on their participation in physical market activities for that year. The NYISO will distribute any additional revenue collected from Transmission Customers based on their participation in non-physical market activity, the Special Case Resource program, and the Emergency Demand Response program for the remainder of the calendar year to each Transmission Customer on the basis of its physical market activity as illustrated formulaically in Appendix M of this manual.

8.1.2. NYISO Annual Budgeted Costs

The NYISO annual budgeted costs to be recovered through Rate Schedule 1 include, but are not limited to, the following costs associated with the operation of the NYS Transmission System by the NYISO, and the administration of the NYISO Tariffs and NYISO Related Agreements by the NYISO:

- Processing and implementing requests for Transmission Service including support of the NYISO OASIS node;
- Coordination of Transmission System operation and implementation of necessary control actions by the NYISO and support for these functions;
- Performing centralized security constrained dispatch to optimally re-dispatch the NYS Power System to mitigate transmission Interface overloads and provide balancing services;
- Administration and operation of the LBMP market and all other markets administered by the NYISO;
- Administration of Control Area Services;
- Administration of the NYISO's Market Power Mitigation Measures and the NYISO's Market Monitoring Plan;
- Maintenance of reliability in the NYCA;
- Provision of Transmission Service;
- Preparation of settlement statements;
- New York State Transmission System studies, when the costs of the studies are not recoverable from a Transmission Customer;

- Engineering services and operations planning;
- Data and voice communications network service coordination;
- Metering maintenance and calibration scheduling;
- Record keeping and auditing;
- Training of NYISO personnel;
- Development and maintenance of information, communication, and control systems;
- Professional services;
- Carrying costs on NYISO assets, capital requirements, and debts;
- Tax expenses, if any;
- Administrative and general expenses;
- Insurance premiums and deductibles related to NYISO operations;
- Any indemnification of or by the NYISO pursuant to Section 2.11.2 of the *NYISO OATT* or Section 12.4 of the *NYISO Services Tariff*;
- Regulatory fees other than those specified in Rate Schedule 1; and
- The NYISO's share of the expenses of Northeast Power Coordinating Council (NPCC), Inc. or its successor.

8.1.3. NERC and NPCC Charges

The NYISO receives an invoice from NERC and NPCC (as defined below) on a quarterly basis for the recovery of the upcoming calendar quarter's costs related to the dues, fees, and related charges of:

1. The NERC for its service as the Electric Reliability Organization for the United States (*ERO*), recovered pursuant to FERC Docket Nos. RM05-30-000, RR06-1-000, and RR06 3-000 and related dockets, and
2. The NPCC: Cross-Border Regional Entity, Inc, or its successors, incurred to carry out functions that are delegated by the NERC and are related to ERO matters pursuant to Section 215 of the FPA.

The NYISO will charge on a quarterly basis, and each Transmission Customer taking service under the NYISO Tariffs will pay, a charge for the recovery of the NERC and NPCC costs as illustrated formulaically in Appendix M of this manual.

8.1.4. Bad Debt Loss Charge

The NYISO will charge, and each Transmission Customer will pay, a charge for the recovery of bad debt losses in accordance with the methodology established in Attachment U of the *NYISO OATT*.

8.1.5. Working Capital Fund Charge

The NYISO will charge, and each Transmission Customer will pay, a charge for the collection and maintenance of the Working Capital Fund in accordance with the methodology established in Attachment V of the *NYISO OATT*.

8.1.6. Non-NYISO Facilities Payment Charge

The NYISO will charge, and each Transmission Customer will pay, a charge, as illustrated formulaically in Appendix M of this manual, for the recovery of the costs for the NYISO's monthly payments to the owners of facilities that are needed for the economic and reliable operation of the NYS Transmission System. At present, the NYISO makes such payments to:

1. Consolidated Edison Co. of New York, Inc. (ConEd) for the purchase, installation, operation, and maintenance of phase angle regulators at the Hopatcong-Ramapo Interconnection between the NYISO and PJM Interconnection, LLC, and
2. Rochester Gas & Electric Corporation for the installation of a 135 MVAR Capacitor Bank at Rochester Station 80 on the cross-state 345 kV system.

8.1.7. Payments Made to Generators Pursuant to Incremental Cost Recovery for Units Responding to Local Reliability Rules G.2 and G.3

The NYISO will charge, and each Transmission Customer will pay based on its Withdrawal Billing Units that are not used to supply Station Power as a third-party provider, a charge for the recovery of the costs of payments to Suppliers pursuant to the incremental cost recovery for units that responded to either (i) Local Reliability Rule G.2 or (ii) Local Reliability Rule G.3, as applicable, for each month, as illustrated formulaically in Appendix M of this manual.

8.1.8. Residuals Costs Payment\Charge

The NYISO's payments for market transactions by Transmission Customers will not equal the NYISO's payments to Suppliers for market transactions. Part of the difference consists of Day-Ahead Congestion Rent, which is balanced by the TOs and discussed in Section 10.1 of this manual. Part of the difference also involves Storm Watch costs, which are described in Section 8.1.8.1 of this manual. The remainder comprises a residual adjustment, which the NYISO will calculate and each Transmission Customer will receive or pay on the basis of its Withdrawal Billing Units. The most significant component of the residual adjustment is the residual costs payment or charge as illustrated formulaically in Appendix M of this manual.

8.1.8.1. Storm Watch Costs

This section describes how Storm Watch costs involve redistributing balancing congestion residuals from NYCA Transmission Customers to Transmission Customers in Load Zone J (N.Y.C.).

Storm Watch, which is also known as Thunderstorm Alert or TSA, is a Local Reliability Rule (LRR) that is activated during actual or anticipated severe weather conditions under which region-specific portions of the New York Transmission System are operated in a more conservative manner by reducing transmission

transfer limits. As provided for in *NYISO Services Tariff* Section 4.1.8, the NYISO calculates Storm Watch Costs by multiplying the Real-Time Shadow Price of any binding constraint associated with a Storm Watch, by the higher of (i) zero; or (ii) the scheduled Day-Ahead flow across the constraint minus the scheduled real-time flow across the constraint (see Transmission and Dispatch Operations Manual Section 4.2.9.1).

Consolidated Edison is the only TO that has the authority to activate the Storm Watch LRR. As a result and as further provided for in *NYISO Services Tariff* Section 4.1.8, redispatching costs incurred as a result of reductions in Transfer Capability caused by activation of a Storm Watch are recovered by the NYISO exclusively from Transmission Customers in Load Zone J (N.Y.C.).

Upon receipt of a request from ConEd to implement a Storm Watch, the NYISO applies the requisite transmission constraint sets to redispatch the transmission grid in a fashion that reliability is effectively supported for the N.Y.C. region. Since the NYISO must manage the overall reliability of the NYCA during the implementation and termination of a the Storm Watch protocols, it may be necessary to ramp into and out of the Storm Watch contingencies in a manner that NYCA transmission grid reliability is also maintained. As a result, the implementation of Storm Watch protocols may lag ConEd's request for implementation, and the termination may lag ConEd's direction to terminate a Storm Watch in order to effectively manage NYCA reliability.

The calculation of Storm Watch redispatch costs and associated allocations are described formulaically in Appendix M of this manual.

8.1.9. Recovery of Special Case Resources and Curtailment Service Providers Costs

The NYISO will charge, and each Transmission Customer will pay, a charge for the recovery of Special Case Resources (SCR) and Curtailment Service Providers (CSP) costs for each month. This charge will be equal to the sum of the hourly charges for the Transmission Customer, as illustrated formulaically in Appendix M of this manual, for each hour in the relevant month and, where applicable, for each Subzone.

8.1.9.1. Recovery of Costs of Payments for Special Case Resources and Curtailment Service Providers Called to Meet the Reliability Needs of a Local System

The NYISO will recover the costs of payments to SCRs and CSPs that were called to meet the reliability needs of a local system. To do so, the NYISO will charge, and each Transmission Customer that serves Load in the Subzone for which the reliability services of the SCRs and CSPs were called will pay, based on its Withdrawal Billing Units that are not used to supply Station Power as a third-party provider, a charge as illustrated formulaically in Appendix M of this manual, for each Subzone.

8.1.9.2. Recovery of Costs of Payments for Special Case Resources and Curtailment Service Providers Called to Meet the Reliability Needs of the New York Control Area

The NYISO will recover the costs of payments to SCRs and CSPs called to meet the reliability needs of the NYCA. To do so, the NYISO will charge, and each Transmission Customer will pay, based on its Withdrawal Billing Units except for Withdrawal Billing Units for Wheels Through, Exports, or to supply Station Power as a third-party provider, a charge as illustrated formulaically in Appendix M of this manual.

8.1.10. Day-Ahead Margin Assurance Payments

The NYISO will charge, and each Transmission Customer will pay, a charge for the recovery of Day-Ahead Margin Assurance Payments (DAMAP) costs for each month. This monthly charge will be equal to the sum of the charges and credits for the Transmission Customer, as broken out in the following two subsections and illustrated formulaically in Appendix M of this manual, for each hour or each day, as applicable, in the relevant month and for each Subzone, where applicable.

8.1.10.1. Day-Ahead Margin Assurance Payments Resulting from Meeting the Reliability Needs of a Local System

The NYISO will recover the costs for DAMAPs incurred to compensate Resources for meeting the reliability needs of a local system, as illustrated formulaically in Appendix M of this manual.

8.1.10.2. Day-Ahead Margin Assurance Payments Resulting from Meeting the Reliability Needs of the NYCA

The NYISO will recover the costs for DAMAPs incurred to compensate Resources for meeting the reliability needs of the NYCA, as illustrated formulaically in Appendix M of this manual.

8.1.11. Import Curtailment Guarantee Payments

The NYISO will charge, and each Transmission Customer will pay based on its Withdrawal Billing Units, a charge for the recovery of the costs of all Import Curtailment Guarantee Payments paid to Import Suppliers each month. This monthly charge will be equal to the sum of the charges and credits for the Transmission Customer, as illustrated formulaically in Appendix M of this manual, for each hour in the relevant month.

8.1.12. Bid Production Cost Guarantee Payments

The NYISO will charge, and each Transmission Customer will pay, a charge for the recovery of Bid Production Cost Guarantee (BPCG) and Demand Reduction Incentive Payment costs for each month. This monthly charge will be equal to the sum of the charges and credits for the Transmission Customer, as broken out below and described formulaically in Appendix M of this manual, for each day and for each Subzone, where applicable.

8.1.12.1. Recovery of Costs of Demand Reduction Bid Production Cost Guarantees and Demand Reduction Incentive Payments

After accounting for imbalance charges paid by Demand Reduction Providers, the NYISO will recover the costs associated with Demand Reduction BPCG payments and Demand Reduction Incentive Payments from Transmission Customers pursuant to the methodology established in Attachment R of the *NYISO OATT*.

8.1.12.2. Recovery of the Costs of Bid Production Cost Guarantees for Additional Generating Units Committed to Meet Forecast Load

If the sum of all Day-Ahead Bilateral Transaction schedules, excluding schedules of Bilateral Transactions with Trading Hubs as their POWs, and all Day-Ahead Market purchases to serve Load in the Day-Ahead schedule is less than the NYISO's Day-Ahead forecast of Load, the NYISO may commit Resources in addition to the reserves that it normally maintains, to enable it to respond to contingencies to meet the NYISO's Day-Ahead forecast of Load. The NYISO will recover a portion of the costs associated with BPCG payments for the additional Resources committed Day-Ahead to meet the Day-Ahead forecast of Load from Transmission Customers pursuant to the methodology established in Attachment T of the *NYISO OATT*. The NYISO will recover the residual costs of such BPCG payments not recovered through the methodology in Attachment T of the *NYISO OATT* through the methodology outlined in Section 8.1.12.6 of this manual.

8.1.12.2.1. Allocation of Costs based upon NYISO forecast load

BPCG costs resulting from the commitment of additional physical supply and imports required to secure system reliability when the NYISO's Day-Ahead load forecast exceeds Day-Ahead purchases of Energy, and Bilaterals, to serve NYCA Load will be allocated as follows:

- To the extent that the NYISO forecast does not exceed actual load, these costs are allocated to bidding entities that are short in real time. These are loads whose real-time consumption is more than they acquired in the DAM. This includes physical loads that have bid their Day-Ahead requirements and virtual suppliers (where their virtual supply is netted against any virtual load scheduled for the same Billing Organization).
- To physical loads, by load-weighted share, to the extent that the NYISO load forecast exceeds actual load. This is net of Attachment T allocations.

8.1.12.2.2. Locational Considerations

The New York Control Area (NYCA) is divided into four locations for the purpose of determining the allocation of the costs based upon NYISO forecast load. The locations were chosen to reflect the major constraints in the NYCA transmission system. Each location is composed of one or more LBMP zones and each LBMP zone exists in only one location.

A determination that the DA forecast Load exceeded the DA Bid load (but not actual RT Load) is done daily based upon the deficiency (the extent to which the NYISO forecast, or actual energy withdrawal,

exceeds the DAM net energy purchase) in each of the four locations. The total daily deficiency of a location is determined by accumulating the hourly deficiencies of the location over a day. A surplus (the extent to which the DAM net energy purchase exceeds the NYISO forecast or actual real-time energy withdrawal) within a given hour at that location will offset a deficiency within the same hour at that location but will not offset a deficiency in a different hour or a different location. The ratio of a location's total daily deficiency, as compared to the accumulated total daily deficiency of all locations in the NYCA, serves to allocate the appropriate share of BPCG to each of the four locations.

BPCG costs allocated to a given location are then further allocated to individual Transmission Customers within that location based upon the Transmission Customer's contribution to the deficiency relative to the total deficiency of the location.

8.1.12.3. Recovery of Costs for Bid Production Cost Guarantees Resulting from Meeting the Reliability Needs of a Local System

The NYISO will recover the costs for BPCG payments incurred to compensate Suppliers for their Resources, other than SCRs, that are committed or dispatched to meet the reliability needs of a local system through a charge for each subzone, as illustrated formulaically in Appendix M of this manual.

8.1.12.3.1. BPCG Allocation for TO-Requested DARU and Other Day-Ahead Committed Local Reliability Units

In order to appropriately allocate the Day-Ahead BPCG payments made to TO-Requested Day-Ahead Reliability Units and other Day-Ahead committed local reliability units, the NYISO assigns a commitment reason to each hour that a generator was committed in the Day-Ahead Market to indicate whether the unit was committed for DARU, for LRR, or was committed economically. Day-Ahead BPCG for units solely committed (in any single day) for TO-requested DARU or LRR reasons is recovered through allocations to LSEs' Loads in the requesting TO's service territory based on their load ratio shares in the TO's subzone during the given day. Day-Ahead BPCG for units solely committed economically is recovered through NYISO-wide load ratio shares during the given day. If a resource has a partial DARU, LRR, or economic commitment over the dispatch day, the BPCG associated with the DARU and LRR commitments is allocated to the corresponding local loads, and any remaining BPCG is allocated based on NYISO-wide load ratio shares as defined below.

Recovery of generator BPCG is divided among those loads responsible for the uplift associated with the various commitment types. For each hour that a generator was committed in the DAM, a commitment reason is associated with that generator, indicating if the unit was committed for DARU, LRR, or economically. For each of these commitment types, the NYISO sums the number of hours for which the unit

was scheduled in the DAM.

The NYISO allocates DAM startup costs by commitment reason, by taking the product of: (a) the daily DAM startup cost for the generator, and (b) the ratio of the DAM total scheduled hours for that commitment type to the DAM total scheduled hours for the dispatch day. This calculation is performed at the generator level.

Next the NYISO calculates the unit's DAM total net cost (total cost (excluding startup cost) - revenue), which can be positive or negative, for each hour. The NYISO sums the hourly DAM total net cost values for the generator for the day by commitment type to create a daily DAM total net cost by commitment type. These two values are added together to arrive at the daily unadjusted BPCG amount for the generator, provided however that if the sum of the two values is not positive it is considered to be zero. The ratio of the daily unadjusted BPCG value for each commitment type to the total daily unadjusted BPCG value for the generator is multiplied by the daily DAM BPCG paid to the given generator. This produces the daily DAM BPCG settlement for each commitment type (DARU, LRR, economic) to be allocated to the loads responsible for each commitment type.

8.1.12.3.2. For Commitment Type TO-Requested DARU BPCG:

The daily DAM BPCG settlement dollars associated with DARU commitments (as described above) are summed for all generators by subzone. Each LSE serving load in that subzone pays a share of the daily DAM BPCG settlement dollars associated with DARU commitments for all generators in that subzone, based on the ratio of its daily load in that subzone to total daily load in that subzone.

8.1.12.3.3. For Commitment Type LRR BPCG:

The daily DAM BPCG settlement dollars associated with LRR commitments (as described above) are summed for all generators in the NYC subzone. LRR commitments in the DAM are made only to satisfy NYC Local Reliability Requirements. Each load in the NYC subzone pays a share of the daily DAM BPCG settlement dollars associated with LRR commitments for all generators in the NYC subzone, based on the ratio of its daily load to total daily load in the NYC subzone.

8.1.12.4. Recovery of Costs of Bid Production Cost Guarantees for Special Case Resources Called to Meet the Reliability Needs of a Local System

The NYISO will recover the costs of BPCG payments incurred to compensate SCRs called to meet the reliability needs of a local system. To do so, the NYISO will charge, and each Transmission Customer that serves Load in the Subzone where the SCR is located will pay based on its Withdrawal Billing Units that are not used to supply Station Power as a third-party provider, a charge, as illustrated formulaically in Appendix M of this manual.

8.1.12.5. Recovery of Costs of Bid Production Cost Guarantees for Special Case Resources Called to Meet the Reliability Needs of the New York Control Area

The NYISO will recover the costs of BPCG payments incurred to compensate SCRs called to meet the reliability needs of the NYCA. To do so, the NYISO will charge, and each Transmission Customer that serves Load in the NYCA will pay based on its Withdrawal Billing Units except for Withdrawal Billing Units for Wheels Through, Exports, or to supply Station Power as a third-party provider, a charge, as illustrated formulaically in Appendix M of this manual.

8.1.12.6. Recovery of Costs of New York Control Area Reliability Bid Production Cost Guarantees

The NYISO will recover the costs of all BPCG payments not recovered through Sections 8.1.12.1, 8.1.12.2, 8.1.12.3, 8.1.12.4, and 8.1.12.5 of this manual, including the residual costs of BPCG payments for additional Resources not recovered through the methodology in Attachment T of the *NYISO OATT*, from all Transmission Customers, as illustrated formulaically in Appendix M of this manual.

8.1.13. Dispute Resolution Payment\Charge

The NYISO will calculate, and each Transmission Customer will receive or pay, a dispute resolution payment or charge, as illustrated formulaically in Appendix M of this manual, for the distribution of funds received by the NYISO or the recovery of funds incurred by the NYISO in the settlement of a dispute.

8.1.14. Credit for Financial Penalties

The NYISO will distribute to each Transmission Customer on a monthly basis, as illustrated formulaically in Appendix M of this manual, any payments that it has collected from Transmission Customers to satisfy: (i) Financial Impact Charges issued pursuant to Sections 4.5.3.2 and 4.5.4.2 of the *NYISO Services Tariff*; (ii) ICAP sanctions issued pursuant to Section 5.12.12 of the *NYISO Services Tariff*; (iii) ICAP deficiency charges pursuant to Section 5.14.3.1 of the *NYISO Services Tariff*, except as provided in Section 5.14.3.2 of the *NYISO Services Tariff*; (iv) market power mitigation financial penalties pursuant to Section 23.4.3.6 of Attachment H of the *NYISO Services Tariff*, except as provided in Section 23.4.4.3.2 of Attachment H of the *NYISO Services Tariff*; and (v) any other financial penalties set forth in the *NYISO Services Tariff* or the *NYISO OATT*. The NYISO will perform this calculation separately for the allocation of the revenue from each financial penalty.

8.1.15. Calculation of FERC Fee Costs

The NYISO shall charge, and each Transmission Customer will pay, a charge for the recovery of the annual FERC fee, as illustrated formulaically in Appendix M of this manual. The annual FERC fee will be allocated ninety-four (94%) to physical market activity and six (6%) to non-physical market activity

respectively. Pursuant to NYISO procedures, the six (6%) of the annual FERC fee allocated to non-physical activity shall be further allocated approximately four percent (4%) to Transmission Congestion Contracts and approximately two percent (2%) to Virtual Transactions. The total charge to each Transmission Customer for recovery of the annual FERC fee shall be the sum of the Transmission Customer's Physical FERC Fee Charge and the Transmission Customer's Non-Physical FERC Fee Charge.

8.2. Scheduling, System Control, and Dispatch Service (Services Tariff)

8.2.1. Annual Budget and Other Non-Budget Charges and Payments

The terms of Schedule 1 of the NYISO OATT are hereby incorporated by reference into this Services Tariff. In applying the terms of Schedule 1 of the NYISO OATT in connection with this Tariff, all terms in Schedule 1 of the NYISO OATT that are applicable to "Transmission Customers" will be similarly applicable to "Customers" under this Rate Schedule 1, and the NYISO will interpret all other defined terms and cross references in Schedule 1 that are specific to the NYISO OATT consistent with the similar terms and provisions of this Tariff, unless otherwise specified.

8.3. Voltage Support Service

Transmission Customers pay the NYISO for Voltage Support Service. The NYISO computes the Voltage Support Service rate as the quotient of: (a) the sum of (i) the projected NYISO payments to generation facilities and Qualified Non-Generator Voltage Support Resources providing Voltage Support Service, based on Sections 15.2.2.1, 15.2.2.2, and 15.2.2.3 of Rate Schedule 2 of the NYISO Services Tariff, and (ii) the total of prior year payments to generation facilities and Qualified Non-Generator Voltage Support Resources supplying Voltage Support Service less the total of payments received by the NYISO from Transmission Customers and LSEs in the prior year for Voltage Support Service (including all payments for penalties); and (b) the annual forecasted transmission usage for the year as projected by the NYISO, including Load within the NYCA, Exports and Wheels Through.

Transmission Customers engaging in Wheels Through, Exports and Purchases from the LBMP Market where the Energy is delivered to a NYCA interconnection with another Control Area, except for Export Transactions at a CTS Enabled Interface with ISO New England resulting from Exports that are not associated with wheels through New England, pay the NYISO a charge for Voltage Support Service equal to the Voltage Support Service rate, as determined above, multiplied by their Energy scheduled in the hour. LSEs pay to the NYISO a charge for Voltage Support Service equal to the Voltage Support Service rate, as determined above, multiplied by the Energy consumed by the LSE's Load located in the NYCA in the hour, provided however, LSEs taking service under Section 5 of the OATT to supply Station Power as a third-

party provider pay to the NYISO a charge for Voltage Support Service equal to the Voltage Support Service rate, as determined above, multiplied by the LSE's Station Power provided under Section 5 of the OATT. For LSEs and all Wheels Through, Exports and Purchases from the LBMP Market for Energy delivered to a NYCA interconnection with another Control Area, except for Export Transactions at a CTS Enabled Interface with ISO New England resulting from Exports that are not associated with wheels through New England, the NYISO calculates the payment hourly. The NYISO bills each Transmission Customer or LSE monthly.

The allocation of the NYISO's costs associated with the provision of Voltage Support Service is illustrated formulaically in Appendix M of this manual.

8.4. Regulation and Frequency Response Service

The NYISO charges Transmission Customers and LSEs serving Load in the NYCA for Regulation and Frequency Response for each hour. For all Actual Energy Withdrawals by Load located in the NYCA, the LSE is considered the Transmission Customer on all Transmission Service and purchases in the LBMP Markets. The NYISO charges Transmission Customers or LSEs taking service under Section 5 of the NYISO OATT to supply Station Power as third-party providers for Regulation and Frequency Response for each day. The Regulation and Frequency Response charge is determined as an hourly or a daily rate, as appropriate, multiplied by the LSE's or Transmission Customer's Load for the hour or by the Transmission Customers or LSEs withdrawals to provide Station Power as a third party provider for the day.

The Regulation and Frequency Response Rate, for the hour or for the day, as appropriate, is computed as the quotient of: (a) the aggregate of Day-Ahead Market and Real-Time Market payments made by the NYISO to Regulation Service Suppliers, including Regulation Revenue Adjustment payments, for the hour or the day, as appropriate, less charges paid by Suppliers, for the hour or the day, as appropriate, for (i) poor Regulation Service performance, (ii) real-time imbalances, and (iii) Regulation Revenue Adjustment charges, less charges paid by Generators that do not provide Regulation Service and do not follow their RTD Base Points sufficiently accurately, as described in Rate Schedule 3-A (Section 15.3A) of the NYISO Services Tariff for the hour or for the day, and (b) the total Load in the NYCA for the hour or for the day, as appropriate.

In any hour where the charges paid by Generators and Suppliers exceed the payments made to Suppliers for this service, the NYISO will not assess a charge against any LSE and any surplus will be applied to the following hour as an offset to subsequent payments. Charges to be paid by LSE for this service are aggregated to render a monthly charge. The NYISO credits charges paid for Regulation and

Frequency Response by Transmission Customers or LSEs taking service under Section 5 of the NYISO OATT to supply Station Power as third-party providers for the day on a Load ratio share basis to Transmission Customers and LSEs serving Load in the NYCA for that day.

The allocation of the NYISO's costs associated with the provision of Regulation and Frequency Response Service is illustrated formulaically in Appendix M of this manual.

8.5. Energy Imbalance Service

For each Transmission Customer that has executed a Service Agreement under the NYISO Services Tariff, Energy Imbalance Service is considered to be supplied by the Real-Time Market and is charged at the Real-Time LBMP. For each Transmission Customer that is not a Customer under the Services Tariff and is receiving service under Section 3 or Section 4 of the OATT, the NYISO will establish a deviation band of +/- 1.5 percent (with a minimum of 2 MW) of the scheduled transaction to be applied hourly to any Energy imbalance that occurs as a result of the Transmission Customer's scheduled transaction(s). Parties should attempt to eliminate Energy imbalances within the limits of the deviation band within thirty (30) days or within such other reasonable period of time as may be established by the NYISO that is generally accepted in the region and consistently adhered to by the NYISO. If an Energy imbalance is not corrected within thirty (30) days or such other reasonable period of time as may be established by the NYISO that is generally accepted in the region and consistently adhered to by the NYISO, the Transmission Customer will compensate the NYISO for such service, subject to the charges described below. Also, Energy imbalances outside the deviation band will be subject to these charges, as well.

For hours when the Transmission Customer's Actual Energy Withdrawals are greater than that customer's scheduled Energy delivery and applicable tolerance band, the Transmission Customer is charged an amount equal to the greater of 150% of the Real-Time LBMP at the Point of Delivery (Withdrawal) or \$100 per megawatt hour. In the event that the Transmission Customer's Actual Energy delivery exceeds that customer's Actual Energy Withdrawals, the Transmission Customer will not receive payment for such Energy.

Energy imbalances resulting from inadvertent interchange between Control Areas will continue to be addressed by the procedures that Control Area operators currently use to address such imbalances. Any increase or decrease in costs resulting from pay back of accumulated inadvertent interchange will be included as a component of the Residual Adjustment.

8.6. Operating Reserves Service

Each Transmission Customer engaging in an Export, except for Export Transactions at a CTS Enabled

Interface with ISO New England resulting from Exports that are not associated with wheels through New England, and each LSE pays an hourly charge equal to the product of: (a) the cost to the NYISO of providing all Operating Reserves for a given hour; and (b) the ratio of (i) the LSE's hourly Load or the Transmission Customer's hourly scheduled Export, except for Export Transactions at a CTS Enabled Interface with ISO New England resulting from Exports that are not associated with wheels through New England to (ii) the sum of all Load in the NYCA and all scheduled Exports, except for Export Transactions at a CTS Enabled Interface with ISO New England resulting from Exports that are not associated with wheels through New England, for a given hour. The cost to the NYISO of providing Operating Reserves in each hour is equal to the total amount that the NYISO pays to procure Operating Reserves on behalf of the market in the Day-Ahead Market and the Real-Time Market, less payments collected from entities that are scheduled to provide less Operating Reserves in the Real-Time Market than in the Day-Ahead Market during that hour. The NYISO aggregates the hourly charges to produce a total charge for a given Dispatch Day.

Transmission Customers taking service under Section 5 of the OATT to supply Station Power as third-party providers pay the NYISO a daily charge for Operating Reserves Service equal to the product of (a) the cost to the NYISO of providing all Operating Reserves for the day less any revenues from penalties collected during the day and (b) the ratio of (i) the Transmission Customer's Station Power supplied under Section 5 of the OATT for the day to (ii) the sum of all Load in the NYCA and all scheduled Exports, except for Export Transactions at a CTS Enabled Interface with ISO New England resulting from Exports that are not associated with wheels through New England, for the day. The NYISO credits the daily charges paid for Operating Reserves by Transmission Customers taking service under Section 5 of the OATT to supply Station Power as third-party providers on a Load ratio share basis to the Load in the NYCA for that day and all scheduled Exports for that day, except for Export Transactions at a CTS Enabled Interface with ISO New England resulting from Exports that are not associated with wheels through New England.

Transmission Customers, including LSEs, may provide for Self-Supply of Operating Reserve by placing generation facilities supplying any one of the Operating Reserves under NYISO Operational Control. The amount that any such customer will be charged for Operating Reserves Services will be reduced by the market value of the services provided by the specified generation facilities as determined in the NYISO Services Tariff.

The allocation of the NYISO's costs associated with the provision of Operating Reserves Service is illustrated formulaically in Appendix M of this manual.

8.6.1. Quick-Start Reserves Service

Amounts due to a Supplier of Quick Start Reserves, pursuant to this Rate Schedule 6 (Section 15.6) of

the Services Tariff, that are attributable to local reliability are recovered from LSEs in the Transmission District of the Supplier selling the Quick Start Reserves on the basis of each LSE's contribution to Load share in the month the payment obligation is incurred.

8.7. Black Start Service

Transmission Customers pay a Black Start and System Restoration Services charge on all Transactions to supply Load in the NYCA (including Internal Bilateral and Import Transactions) equal to the product of (a) the Transmission Customer's hourly Load Ratio Share and (b) the hourly embedded cost charge for Black Start and System Restoration Services (net of all payments forfeited due to a Generator's failure to pass a required test of its ability to provide Black Start and System Restoration Services).

The full restoration of the NYS Power System will require additional Black Start and System Restoration Services from Generators, which are located in local Transmission Owner areas and which are not presently listed in the NYISO Black Start Plan. Although the NYISO Plan will restore a major portion of the NYS Power System, there are portions of the NYS Power System that will remain under Transmission Owner restoration control. Where the Transmission Owners' restoration plans require additional local Black Start and System Restoration Services, the NYISO makes payments for such local services directly to the Generators that provide them, pursuant to Section 15.5.2 or 15.5.4 of Rate Schedule 5 of the NYISO Services Tariff. The LSEs in those local Transmission Owner areas will be additionally charged for Black Start and System Restoration Services by the NYISO using the formula set forth in the following paragraph.

The NYISO charges LSEs in those local Transmission Owner areas an amount equal to the product of (a) the Transmission Customer's hourly Load Ratio Share of Load requiring local Black Start and System Restoration Services, and (b) the hourly embedded cost charge for providing local Black Start and System Restoration Services capability (net of all payments forfeited due to a local generation facility's failure to pass a Black Start and System Restoration Services capability test), as described in Rate Schedule 5 (Section 15.5) of the Services Tariff.

The allocations of the NYISO's costs associated with the provision of Black Start and Local Black Start and System Restoration Service are illustrated formulaically in Appendix M of this manual.

8.8. Penalty Cost Recovery

This section describes the NYISO's cost recovery process, as provided for under Rate Schedule 11 (Section 6.11) of the NYISO OATT, for monetary penalties assessed by the FERC, NERC and/or NPCC against the NYISO as the Registered Entity for a violation of a NERC Reliability Standard(s).

8.8.1. Allocation of Costs Associated with NERC Penalty Assessments When NYISO is the Registered Entity

The defined terms referenced herein are defined in Section 6.11.1.2 of Schedule 11 or Section 1 of the OATT. If the FERC, NERC and/or NPCC assesses a monetary penalty against the NYISO as the Registered Entity for a violation of a NERC Reliability Standard(s), and the conduct of a Customer or Customers contributed to the Reliability Standard violation(s) at issue, then the NYISO may directly allocate such penalty costs or a portion thereof to the Customer or Customers whose conduct contributed to the Reliability Standards violation(s), provided that all of the following conditions have been satisfied:

- Pursuant to the Compliance Monitoring and Enforcement Program (CMEP), the Customer or Customers received notice and an opportunity to fully participate in the underlying CMEP proceeding;
- The CMEP proceeding produced a root cause finding, subsequently filed with FERC, that the Customer contributed, either in whole or in part, to the NERC Reliability Standards violation(s); and
- A NERC filing of the root cause finding identifying the Customer's or Customers' conduct as causing or contributing to the Reliability Standards violation charged against the NYISO as the Registered Entity is made at FERC.

The NYISO will notify the Customer or Customers found to have contributed to a violation, either in whole or in part, in the CMEP proceedings. Such notification will set forth in writing the NYISO's intent to invoke this section and directly assign the costs associated with a monetary penalty to the Customer or Customers. Such notification will (i) state that the NYISO believes the criteria for direct assignment and allocation of costs under this Schedule have been satisfied; and (ii) describe the underlying factual basis supporting a penalty cost assignment, including a description of the conduct contributing to the violation and the nature of the violation of the NYISO Tariffs or NYISO Related Agreement requirements. A failure by a Customer or Customers to participate in the CMEP proceedings will not prevent the NYISO from directly assigning the costs associated with a monetary penalty to the responsible Customer or Customers provided all other conditions set forth herein have been satisfied.

Where the Regional Entity's and/or NERC's root cause analysis finds that more than one party's conduct contributed to the Reliability Standards violation(s), the NYISO will inform all involved Customers and will make an initial apportionment for purposes of the cost allocation on a basis reasonably proportional to the parties' relative fault consistent with NERC's root cause analysis. If the NYISO and the involved Customer(s) agree on the proportion of penalty cost allocation, such agreement will be submitted to the FERC pursuant to Section 205 of the Federal Power Act for approval. Should the Customer(s) disagree with the NYISO's initial apportionment of the penalty based on each party's relative fault, then the parties will meet in an attempt to informally resolve the penalty allocation. If the parties cannot agree informally, the matter will be submitted to the FERC pursuant to Section 205 of the Federal Power Act.

Once there is a final order by FERC regarding the NYISO's ability to directly assign the penalty amounts, the NYISO will include such amounts in the appropriate Customer's or Customers' next monthly invoice. Such payment amount will be due with interest calculated at the FERC authorized refund rate from the date of payment of the penalty by the NYISO, provided however, nothing precludes the Customer or Customers from paying such penalty when it becomes due for the NYISO to avoid paying interest costs. If the Customer pays such penalty under protest when it becomes due and prior to a final order by FERC and such Customer is thereafter found not liable, the Customer is entitled to a refund of the penalty amount from the NYISO, with interest calculated at the FERC authorized refund rate from the date the Customer pays the penalty.

The allocation of costs associated with NERC penalty assessments is illustrated formulaically in Appendix M of this manual.

8.8.2. Allocation of Costs Associated with NERC Penalty Assessments When Customer is the Registered Entity

If the FERC, NERC and/or NPCC assesses a monetary penalty against a Customer as the Registered Entity for a violation of a NERC Reliability Standard(s), and the conduct of the NYISO contributed to the Reliability Standard violation(s) at issue, then such Customer may directly allocate such penalty costs or portion thereof to the NYISO to the extent the NYISO's conduct contributed to the Reliability Standards violation(s), provided that the following conditions have been satisfied:

- Pursuant to the CMEP, the NYISO received notice and an opportunity to fully participate in the underlying CMEP proceeding;
- The CMEP proceeding produced a root cause finding, subsequently filed with FERC, that the NYISO contributed, either in whole or in part, to the NERC Reliability Standards violation(s); and
- A NERC filing of the root cause finding identifying the NYISO's conduct as causing or contributing to the Reliability Standards violation charged against the Customer as the Registered Entity is made at FERC.

The Customer must notify the NYISO if the NYISO is found to have contributed to a violation, either in whole or in part in the CMEP proceedings. Such notification must set forth in writing the Customer's intent to invoke Section 6.11.1.4 of Schedule 11 of the OATT and directly assign the costs associated with a monetary penalty to the NYISO. Such notification must (i) state that the Customer believes the criteria for direct assignment and allocation of costs under this provision have been satisfied; and (ii) describe the underlying factual basis supporting a penalty cost assignment, including a description of the conduct contributing to the violation and, where applicable, the nature of the violation of the NYISO Tariffs or NYISO Related Agreement requirements. A failure by the NYISO to participate in the CMEP proceedings will not prevent the Customer from directly assigning the costs associated with a monetary penalty to the

NYISO provided all other conditions set forth herein have been satisfied.

Where the Regional Entity's and/or NERC's root cause analysis finds that the NYISO's conduct contributed to the Reliability Standards violation(s), the Customer must inform the NYISO and make an initial apportionment for purposes of the cost allocation on a basis reasonably proportional to the parties' relative fault consistent with NERC's root cause analysis. If the NYISO and the involved Customer agree on a proportion of penalty cost allocation, such agreement must be submitted to the FERC pursuant to Section 205 of the Federal Power Act. Should the NYISO disagree with the Customer's initial apportionment of the penalty based on each party's relative fault, then the parties will meet in an attempt to informally resolve the penalty allocation. If the parties cannot agree informally, the matter will be submitted to the FERC pursuant to Section 205 of the Federal Power Act.

Once there is a final order by FERC regarding the Customer's direct assignment of costs to the NYISO, the NYISO will pay such amount with interest calculated at the FERC authorized refund rate from the date of payment of the penalty by the Registered Entity. The NYISO will thereafter pursue the recovery of such costs in accordance with Section 8.8.4, below. Nothing precludes the NYISO from paying such penalty when it becomes due for the Registered Entity to avoid paying interest costs. If the NYISO pays such penalty under protest when it becomes due and prior to a final order by FERC and the NYISO thereafter is found not liable, the NYISO is entitled to a refund of the penalty amount from the Customer with interest calculated at the FERC authorized refund rate from the date of payment of the penalty by the NYISO. The NYISO will thereafter refund any amounts that were collected from all Customers pursuant to Section 8.8.4, below.

The allocation of costs associated with NERC penalty assessments is illustrated formulaically in Appendix M of this manual.

8.8.3. Allocation of Costs Associated with Other Reliability Penalty Assessments

The NYISO is responsible for performing specific functions under other applicable state and federal regulatory requirements and may be assessed penalties by other regulatory bodies for violations of applicable regulatory requirements. Section 8.8.4 of this manual furnishes a mechanism by which the NYISO may seek to recover monetary penalties imposed by such regulatory authorities. Penalties that are assessed against the NYISO on or after the effective date of this Section will be recoverable as provided in this Section regardless of the date of the violation(s) for which the penalty is assessed. Notwithstanding any provisions of the NYISO Tariffs or NYISO Related Agreements, including those provisions requiring stakeholder approval for Section 205 filings in certain instances, the NYISO has the independent authority to make Section 205 filings in accordance with the provisions of this Schedule 11 after consultation with

the Management Committee as provided in Section 5.1.1.3 of the Services Tariff or Section 2.11.6(c) of the NYISO OATT.

8.8.4. Allocation of Costs Associated with Penalty Assessments

Where a particular Customer or Customers cannot be identified as the root cause of a penalty assessment against the NYISO or if the NYISO is assessed a penalty because of its own action or inaction that resulted in a reliability standard violation or a violation of applicable state or federal regulatory requirements, or if the NYISO is allocated a penalty as described above in Section 8.8.2, the NYISO may seek to recover such penalty costs in accordance with this provisions described herein. Any penalty assessments must first be approved by FERC on a case-by-case basis, as provided in Reliability Standard Compliance and Enforcement in Regions with Regional Transmission Organizations or Independent System Operators, Docket No. AD07-12-000, 122 FERC ¶ 61,247 (2008), or any successor policy.

Any and all costs associated with the imposition of NERC Reliability Standards penalties or penalties assessed by other regulatory authorities that may be assessed against the NYISO either directly by NERC, other regulatory authority or allocated by a Customer or Customers under Schedule 11 (Section 6.1.1) of the OATT will be (i) paid by the NYISO notwithstanding the limitation of liability provisions in the OATT Tariff or the Services Tariff; and (ii) recovered through an allocation of 50% to all injection billing units and 50% to all withdrawal billing units, after consultation with the Management Committee as provided in Section 5.1.1.3 of the Services Tariff or Section 2.11.6(c) of the NYISO OATT, or as otherwise approved by the FERC. The rate to be applied to injection and withdrawal billing units in each month is the quotient of the amount of these costs to be included in the month divided by the sum of the total injection and withdrawal billing units for the month. This rate is then multiplied by each Transmission Customer's aggregate injection and withdrawal billing units for the month. The Transmission Customer's injection billing units are based on Actual Energy Injections (for all internal injections) or Scheduled Energy Injections (for all Import Energy injections) in the New York Control Area, including injections for Wheels Through. The Transmission Customer's withdrawal billing units are based on its Actual Energy Withdrawals for all Transmission Service to supply Load in the NYCA, and hourly schedules for all Wheels Through and Exports.

Once there is a final order by FERC regarding the NYISO's ability to recover penalty amounts, the NYISO will include such amounts in the next monthly invoice utilizing the billing units for the month of infraction. For purposes of this calculation, the "month of infraction" is defined as the service month in which the violation occurred. Should the penalty be assessed for a violation occurring over multiple service months, the penalty to be recovered for each service month will be the total penalty to be recovered divided by the

number of months over which the violation occurred.

Whenever practicable, the NYISO will recover this charge in the invoice issued in the month following the month in which the NYISO incurs the penalty charge. The NYISO may recover penalty charges over several months if, in its discretion, the NYISO determines such method of recovery to be a prudent course of action. In the event that one or more entities who otherwise would have been apportioned a share of the penalty are no longer Customers, the NYISO will adjust the remaining Customers' shares of the penalty costs, on a proportional basis, if necessary to fully recover the penalty charge.

8.9. Reliability Facilities Charge Recovery

This section describes the NYISO's cost recovery process, as provided for under Rate Schedule 10 (Section 6.10) of the NYISO OATT, for costs related to each regulated reliability transmission project undertaken pursuant to a determination by the NYISO that a regulated solution is needed to address reliability needs identified by the NYISO in its reliability planning process in accordance with Section 31.2.6.4 of Attachment Y of the NYISO OATT and the NYISO/TO Reliability Agreement.

8.9.1. Allocation of Costs Associated with Reliability Facilities Charge

The Reliability Facilities Charge (RFC) recovers costs related to each regulated reliability transmission project undertaken pursuant to a determination by the NYISO that a regulated solution is needed to address reliability needs identified by the NYISO in its reliability planning process in accordance with Section 31.2.6.4 of Attachment Y of the NYISO OATT and the NYISO/TO Reliability Agreement. A regulated reliability transmission project includes a regulated backstop transmission project or a regulated transmission Gap Solution proposed by a Responsible Transmission Owner, or an alternative regulated transmission project proposed by a TO or an Other Developer, provided that such alternative regulated transmission project has been determined by the appropriate state regulatory agency(ies) as the preferred solution to the identified Reliability Need. The RFC does not apply to projects undertaken by TOs pursuant to Local Transmission Owner Planning Processes in accordance with Section 31.1.1.2 and Section 31.2.1 of Attachment Y of the NYISO OATT.

The RFC comprises the revenue requirements related to: (i) each regulated reliability transmission project filed with FERC by a TO pursuant to the provisions of this Section 8.9; (ii) any costs incurred by NYPA and filed with FERC by the NYISO pursuant to the provisions of this Section 8.9; and (iii) any FERC-approved costs incurred by an Other Developer as set forth in Section 8.9.4, below, and filed with FERC by the NYISO or Other Developer pursuant to the provisions of this Section 8.9. Any costs incurred by LIPA and allocable to other Transmission Districts will be collected under a separate LIPA RFC and filed with

FERC by the NYISO, as set forth in Section 8.9.3, below.

The RFC provides for full recovery of all reasonably incurred costs related to the preparation of proposals for, and the development, construction, operation, and maintenance of, any regulated reliability transmission project undertaken pursuant to Attachment Y of the OATT, including all reasonable costs related to such a project that is halted in accordance with the provisions of the NYISO's tariff and the NYISO/TO Reliability Agreement. Subject to regulatory acceptance, the RFC will include a reasonable return on investment and any applicable incentives. The RFC is separate from the Transmission Service Charge (TSC) and the NYPA Transmission Adjustment Charge (NTAC) determined in accordance with Attachment H of the NYISO OATT. With respect to the recovery of costs incurred by LIPA and NYPA, the provisions of Section 8.9.2 below, will not apply to LIPA or NYPA, except as provided for in Section 8.9.3 below. The recovery of costs related to development, construction, operation, and maintenance of a regulated reliability transmission project undertaken by LIPA or NYPA will be pursuant to the provisions of Section 8.9.3, below. The recovery of costs related to development, construction, operation, and maintenance of an Alternative Regulated Solution proposed by an Other Developer will be pursuant to the provisions of Section 8.9.4, below.

The RFC in Rate Schedule 10 serves as a template for the cost recovery mechanism to be utilized by a TO or Other Developer to request cost recovery when filing a project for approval with FERC. Therefore, each project may have different cost allocation methodologies that are specific to the nature of the project and would be reflected in additional Rate Schedules in the NYISO OATT. This manual will only reflect the template of Rate Schedule 10. However, the computation of the RFC for all projects described in Sections 8.9.2, 8.9.3, and 8.9.4 below is represented formulaically in Appendix M of this manual. The addition of formulas in new Rate Schedules for specific projects will also be reflected in Appendix M of this manual.

8.9.2. Recovery of Transmission Owner's Costs Related to Regulated Reliability Transmission Solutions

Each Transmission Owner will have on file at FERC the rate treatment that will be used to derive and determine the revenue requirement to be included in the RFC, and for the LIPA RFC as applicable, for regulated transmission projects undertaken pursuant to a determination by the NYISO that a regulated solution is needed to address reliability needs identified by the NYISO in its reliability planning process in accordance with Section 31.2.6.4 of Attachment Y of the NYISO OATT. The filing will provide for the recovery of the full revenue requirement for a regulated reliability transmission project consistent with FERC regulations including but not limited to any incentives for the construction of transmission projects provided for in Section 219 of the Federal Power Act and the FERC regulations implementing that section. Pursuant to a determination by the NYISO that a regulated solution is needed to address reliability needs

identified by the NYISO in its reliability planning process in accordance with Section 31.2.6.4 of Attachment Y of the NYISO OATT, the Responsible TO(s) proceeding with a Regulated Transmission Backstop Solution or a TO proceeding with an Alternative Regulated Transmission Solution that is selected by the appropriate state agency as the preferred solution, will proceed with the approval process for all necessary federal, state, and local authorizations for the requested project to which this RFC applies.

Upon receipt of all necessary federal, state, and local authorizations, including FERC acceptance of the rate treatment, the TO(s) will commence construction of the project.

Upon completion of the project, the TO(s) or the NYISO, as applicable, will make an informational filing with FERC to provide the final project cost and resulting revenue requirement to be recovered pursuant to this Section 8.9. The final project cost and resulting revenue requirement will be reduced by any amounts that, pursuant to Section 25.7.12.3.3 of Attachment S to the NYISO OATT, have been previously committed by or collected from Developers for the installation of System Deliverability Upgrades (SDUs) required for the interconnection of generation or merchant transmission projects. The resulting revenue requirement will become effective and recovery of project costs pursuant to this Section 8.9 will commence upon the making of the informational filing with FERC, and will not require and will not be dependent on a re-opening or review of the TO(s)' revenue requirements for the TSCs and NTAC set forth in Attachment H of the NYISO OATT.

This section also applies to the recovery of all reasonably incurred costs related to either a regulated backstop transmission project or an alternative regulated transmission project that has been selected by the appropriate state agency(ies) as the preferred solution and that is later halted, including but not limited to reasonable and necessary expenses incurred to implement an orderly termination of the project, in accordance with the provisions of the NYISO OATT and the NYISO/TO Reliability Agreement. Following the informational filing, the NYISO will bill the RFC or LIPA RFC, as applicable. The Transmission Owners may propose a non-transmission solution subject to state jurisdiction to address a reliability need included in the Comprehensive Reliability Plan, provided that the appropriate state agency(ies) has established procedures to ensure full and prompt recovery of all reasonably incurred costs related to a project, comparable to those set forth in the OATT for cost recovery for regulated reliability transmission projects.

The RFC is billed by the NYISO and paid by the LSEs, including TOs, competitive LSEs, and municipal systems, located in load zones to which the costs of the transmission facilities have been allocated in accordance with Attachment Y of the NYISO OATT. The filed annual revenue requirement will be the basis for the monthly RFC Rate (\$/MWh) as described below and is applied by the NYISO to each LSE based on its Actual Energy Withdrawals available for the prior month for those zones that are determined to be

allocated the costs of the project in accordance with Attachment Y of the NYISO OATT. To the extent that incremental transmission rights owned by the TO or Other Developer sponsoring the project are created as a result of a transmission project implemented in accordance with Attachment Y of the NYISO OATT, those incremental transmission rights that can be sold will be auctioned or otherwise sold by the NYISO. The NYISO will disburse or credit the associated revenues on a monthly basis to the LSEs in proportion to their funding of the Reliability Facilities. This revenue will be used as an offset in the calculation of the RFC as described below. The incremental transmission rights will continue to be sold for the depreciable life of the project, and the revenues offset discussed above will commence upon the first payment of revenues related to a sale of incremental transmission rights on or after the RFC is implemented for a specific project. These incremental revenues will not require and will not be dependent on any reopening or any review of the TO(s)' TSCs or NTAC under Attachment H of the NYISO OATT.

The NYISO will maintain all data required to calculate the RFC. The NYISO Long Term Planning Department will maintain the annual revenue requirements to be included in the RFC on file with FERC and the allocation of the costs to the appropriate load zones for the RFC. The NYISO Auxiliary Market Operations Department will track and maintain the revenue from the sale of the incremental transmission rights for the RFC. For each project, the data, including the timing of the data, used for each RFC will be provided to all stakeholders for review at the Electric System Planning Working Group prior to the calculation of the RFC. The data will then be provided to Customer Settlements for billing.

The NYISO will calculate the RFC to be recovered from each LSE for each month as follows:

The monthly Reliability Facilities costs that will be recovered from LSEs from each affected zone are computed as the sum over all projects of: (a) the Annual Revenue Requirements for each project, as described in this Section 8.9.2, above, minus the annual revenue from incremental transmission rights for each project as described in this Section 8.9.2, above; divided by (b) 12 months; and multiplied by (c) the Zonal cost allocation for each project to which the costs of the transmission facilities have been allocated in accordance with Attachment Y of the NYISO OATT.

The monthly RFC rate used for the recovery of such monthly Reliability Facilities costs for each affected zone is then computed as the quotient of: (a) the monthly Reliability Facilities costs, as computed above, for the respective Zone, and (b) the total Actual LSE Energy Withdrawals in the respective Zone for the same month.

Load Serving Entities are then charged an RFC for each affected Zone for the month equal to the product of: (a) the LSE's total Actual LSE Energy Withdrawals in the Zone in that month and (b) the monthly RFC rate for the respective Zone, as computed above.

The LSE's monthly charge is an aggregate of the RFCs, as calculated above for that LSE, for all Zones in the given month. The RFC amount will appear on the LSEs invoice as a series of manual adjustments for each individual project and each individual zone.

The NYISO will collect the appropriate RFC revenues on a monthly basis and remit those revenues to the appropriate TO(s) in accordance with the NYISO billing and settlement procedures pursuant to Section 2.7.2.5 of the NYISO OATT.

8.9.3. Recovery of Costs by an Unregulated Transmitting Utility

An Unregulated Transmitting Utility is a TO that, pursuant to Section 201(f) of the FPA, is not subject to the Commission's jurisdiction under Sections 205 and 206 of the FPA. The recovery of costs related to the preparation of proposals for, and the development, construction, operation, and maintenance of, a regulated reliability transmission project undertaken pursuant to Attachment Y of the NYISO OATT by LIPA, as an Unregulated Transmitting Utility, will be conducted as follows.

Upon the request of the NYISO, an Unregulated Transmitting Utility will proceed with the process of receiving any necessary authorization for the requested project. Upon receipt of all necessary federal, state, and local authorizations, the Unregulated Transmitting Utility will commence with construction of the project.

Transmission Owners other than LIPA that propose an alternative regulated transmission project on Long Island would recover any costs per Section 8.9.2, above. Other Developers that propose an alternative regulated transmission project on Long Island would recover any costs per Section 8.9.4, below. Any costs incurred for a regulated backstop reliability transmission project or an alternative regulated transmission project undertaken by LIPA, as an Unregulated Transmitting Utility, will be recovered as follows:

- a. *For costs to LIPA customers:* Cost will be recovered pursuant to a rate recovery mechanism approved by the LIPA's Board of Trustees pursuant to Article 5, Title 1-A of the New York Public Authorities Law, Sections 1020-f(u) and 1020-s. Upon approval of the rate recovery mechanism, LIPA will provide to the NYISO, for purposes of inclusion within the NYISO OATT and filing with FERC on an informational basis only, a description of the rate recovery mechanism and the rate that LIPA will charge and collect from responsible entities within the Long Island Transmission District in accordance with the NYISO cost allocation methodology pursuant to Section 31.4.2.2 of Attachment Y of the NYISO OATT.
- b. *For costs to other Transmission Districts:* Where the NYISO determines that there are responsible entities outside of the Long Island Transmission District that should be allocated a portion of the costs of the regulated backstop reliability transmission solution or an alternative regulated transmission solution undertaken by LIPA, LIPA will inform the NYISO of the amount of such costs. Such costs will be an allocable amount of the cost base recovered through the recovery mechanism described in Section 8.9.3(a), above, in accordance with the formula set forth in Section 8.9.2, above. The costs of a LIPA regulated

backstop reliability transmission project or an alternative regulated transmission solution allocable to responsible entities outside of the Long Island Transmission District will constitute the “revenue requirement” that the NYISO will include and recover through a separate “LIPA RFC.” The NYISO will file the LIPA RFC with the Commission as an informational filing. The NYISO will file such RFC for Commission review under the same “comparability” standard as is applied to review of changes in LIPA’s TSC under Attachment H of the NYISO OATT. LIPA will intervene in support of such filing at the Commission and will take the responsibility to resolve all concerns about the contents of the filing that might be raised in such proceeding.

The NYISO will bill for LIPA the LIPA RFC to responsible entities in Transmission Districts other than the Long Island Transmission District consistent with Section 8.9.2, above, and will remit the revenues collected to LIPA on a monthly basis.

The inclusion in the NYISO OATT or in a FERC filing on an informational basis of the charges for recovery of costs incurred by LIPA or NYPA related to a regulated project undertaken pursuant to Attachment Y in the NYISO OATT, as provided for above in this section, or the inclusion of such charges in the NYISO RFC described in Section 8.9.3(b), above, will not be deemed to modify the treatment of such rates as non-jurisdictional pursuant to Section 201(f) of the FPA.

8.9.4. Recovery of Costs Incurred by an Other Developer Related to an Alternative Regulated Solution

The RFC will be used as the mechanism to recover the costs of an alternative regulated reliability transmission project, pursuant to a determination by the NYISO that a regulated solution is needed to address reliability needs identified by the NYISO in its reliability planning process in accordance with Section 31.2.6.4 of Attachment Y of the NYISO OATT, that is proposed, developed, or constructed by an Other Developer who is otherwise authorized to propose, develop, or construct a regulated transmission project under applicable state and federal law; that has been determined by the appropriate state regulatory agency(ies) as the preferred solution to the identified Reliability Need; and that is authorized by FERC to recover costs under this rate mechanism, *provided, however*, nothing in this cost recovery mechanism will be deemed to create any additional rights for an Other Developer to proceed with a regulated transmission project that such Other Developer does not otherwise have at law. The provisions detailed in Section 8.9.2, above, will be applicable to the recovery of the costs incurred by an Other Developer for proposing, developing, and constructing an alternative regulated transmission project that has been determined by the appropriate state regulatory agency(ies) as the preferred solution to the identified Reliability Need.

Upon receipt of all necessary federal, state, and local authorizations, including FERC acceptance of a Section 205 filing authorizing cost recovery under the NYISO tariff, the Other Developer will commence construction of the project. Upon completion of the project, the Other Developer and/or the NYISO, as

applicable, will file with FERC to provide the final project cost and resulting revenue requirement to be recovered pursuant to this Section 8.9. The resulting revenue requirement will become effective and recovery of project costs pursuant to this Section 8.9 will commence upon the acceptance of the filing by FERC. This section also applies to the recovery of all reasonably incurred costs related to a project that has been selected as the preferred solution by the appropriate state regulatory agency(ies) and is later halted, including but not limited to reasonable and necessary expenses incurred to implement an orderly termination of the project, in accordance with the provisions of the NYISO OATT.

Other Developers may also propose a non-transmission solution subject to state jurisdiction to address a Reliability Need included in the Comprehensive Reliability Plan.

8.10. Recovery of the Highway Facilities Charge

The Highway Facilities Charge (HFC) recovers the portion of the costs related to Highway System Deliverability Upgrades (Highway SDUs) required for deliverability under Section 25.7.12 of Attachment S of the NYISO OATT that are allocated to LSEs. This rate mechanism does not apply to: (i) the extent that a Highway SDU is undertaken and funded pursuant to Attachment Y of the NYISO OATT; (ii) costs for System Upgrade Facilities or Highway SDUs that are allocated to Developers or Interconnection Customers in accordance with Attachments S, X, or Z of the NYISO OATT; or (iii) costs of transmission expansion projects undertaken in connection with an individual request for Transmission Service under Sections 3.7 or 4.5 of the NYISO OATT.

The HFC comprises the revenue requirements related to each Highway SDU filed with FERC by a TO pursuant to the provisions of this Section 8.10. The HFC in Rate Schedule 10 serves as a template for the cost recovery mechanism to be utilized by a TO or Other Developer to request cost recovery when filing a project for approval with FERC. Therefore, each project may have different cost allocation methodologies that are specific to the nature of the project and would be reflected in additional Rate Schedules in the NYISO OATT. This manual will only reflect the template of Rate Schedule 12. The addition of formulas in new Rate Schedules for specific projects will also be reflected in Appendix M of this manual. The HFC provides for full recovery of all reasonably incurred costs related to the development, construction, operation, and maintenance of any Highway SDU undertaken pursuant to Attachment S of the NYISO OATT (including costs for a Highway SDU that is subsequently halted through no fault of the constructing TO) that are allocated to LSEs.

Subject to regulatory acceptance, the HFC includes a reasonable return on investment. The HFC is separate from the Transmission Service Charge (TSC) and the NYPA Transmission Adjustment Charge

(NTAC) determined in accordance with Attachment H of the NYISO OATT and the Reliability Facilities Charge (RFC) established in accordance with Attachment Y and Rate Schedule 10 (Section 6.10) of the NYISO OATT.

8.10.1. Recovery of Transmission Owner's Costs Related to Highway System Delivery Upgrades

Prior to the implementation of any HFC, each TO must file with FERC the rate treatment that will be used to derive and determine the revenue requirement to be included in the HFC for Highway SDUs undertaken pursuant to a Class Year Deliverability Study and allocated to LSEs in accordance with Section 25.7.12 of Attachment S of the NYISO OATT. The rate treatment will provide for the recovery of the full revenue requirement for that portion of a Highway SDU that is allocated to LSEs consistent with the provisions of Attachment S and this Section 8.10.

Pursuant to 8.10a determination by the NYISO that the threshold for construction of a Highway SDU has been crossed in accordance with Section 25.7.12.3.1 of Attachment S of the NYISO OATT, the TO(s) responsible for constructing the Highway SDU will proceed with the approval process for all necessary federal, state, and local authorizations for the requested project to which this HFC applies. Upon receipt of all necessary federal, state, and local authorizations, including FERC acceptance of the rate treatment, the TO(s) will commence construction of the project.

The portion of the cost of the Highway SDU to be allocated to LSEs is reduced by any Headroom payments made to the constructing TO by a subsequent Developer or Interconnection Customer prior to the completion of the project. Upon completion of the project, the TO(s) will make an informational filing with FERC to provide the final project cost and resulting revenue requirement to be recovered through the HFC. The recovery of project costs through the HFC will commence on the effective date proposed in the informational filing and accepted by FERC and does not require and is not dependent on a re-opening or review of the TO(s)' revenue requirements for the TSCs and NTAC set forth in Attachment H of the NYISO OATT. Following the informational filing, the NYISO will bill the HFC as applicable.

8.10.2. Highway Facilities Charge Revenue Requirement Recovery

The HFC is invoiced by the NYISO and paid by the LSEs allocated in accordance with Section 25.7.12.3.2 of Attachment S of the NYISO OATT. All LSEs to which costs have been allocated, including TOs, non-TO LSEs, and municipal systems, are invoiced by the NYISO.

The revenue requirement filed, as described in Section 8.10.1 of this manual, is the basis for the monthly HFC, and is allocated by the NYISO to each LSE based on its proportionate share of the ICAP requirement in the statewide Capacity market, adjusted to subtract locational Capacity requirements as set

forth in Attachment S of the NYISO OATT. The monthly HFC includes operation and maintenance costs for the proportionate share of the Highway SDU funded by LSEs.

Load Serving Entities will not be responsible for actual costs in excess of their share of the final Class Year estimated cost of the Highway SDU if the excess results from causes within the control of a TO(s) responsible for constructing the Highway SDU as described in Section 25.8.6.4 of Attachment S of the NYISO OATT.

To the extent that Incremental Transmission Congestion Contracts (TCCs) are created as a result of a Highway SDU implemented in accordance with Attachment S of the NYISO OATT, that portion of those Incremental TCCs attributed to LSEs pursuant to Attachment S that can be sold will be auctioned or otherwise sold by the NYISO. The NYISO will disburse or credit the associated revenues to the LSEs in proportion to their funding of their Highway SDUs. Such revenues will be disbursed or credited monthly as an offset to the monthly HFC. These Incremental TCCs will continue to be sold for so long as LSEs are responsible for funding the Highway SDU through an HFC, and the disbursements or credits discussed above will commence upon the first payment of revenues related to a sale of Incremental TCCs on or after the HFC is first invoiced for a specific Highway SDU. These incremental revenues do not require and are not dependent on any reopening or any review of the TO(s)' TSCs or NTAC under Attachment H of the NYISO OATT.

The NYISO will collect the appropriate HFC revenues on a monthly basis and remit those revenues to the appropriate TO(s) in accordance with the NYISO's billing and settlement procedures pursuant to the NYISO OATT. The monthly HFC will be based on the ICAP requirement in the statewide Capacity market, adjusted to subtract locational Capacity requirements for those LSEs determined to be allocated the costs of the project in accordance with Section 25.7.12 of Attachment S of the NYISO OATT.

For Year 1, the LSEs' ICAP requirements for the most recent NYISO Capability Year prior to the in-service date of the Highway SDU will be used for cost allocation. For subsequent years, the billing cycle will be adjusted, if necessary, to start following the establishment of the LSEs' ICAP requirements for the current Capability Year. Each LSE's share of the monthly HFC will be computed as the quotient of: the (a) product of (i) the Monthly HFC and (ii) the LSE's ICAP Requirement minus the LSE's Locational ICAP Requirement, if applicable; and (b) the Statewide ICAP Requirement minus the Sum of Locational ICAP Requirements.

NYISO's Interconnection Planning Department will track the annual revenue requirements to be included in the HFC on file with FERC and supplied to Customer Settlements. The NYISO Auxiliary Market Operations will keep track of LSE's monthly ICAP requirements and supply them to Customer Settlements

for billing. The HFC will appear on the monthly invoice as a manual adjustment for both the TOs and LSEs.

Billing true-ups to account for load shifting between LSEs will be based on the existing ICAP methodology, as appropriate. These true-ups will occur on a monthly basis. Revenue shortfalls, if any, will be allocated to the remaining LSEs in proportion to their respective ICAP requirements for the Capability Year. Billing adjustments for revenue shortfalls will occur on a monthly basis.

8.10.3. Headroom Accounting

As new generators and merchant transmission facilities come on line and use the Headroom created by a prior Highway SDU, the Developers or Interconnection Customers of those new facilities will reimburse prior Developers or Interconnection Customers or will compensate the LSEs who funded the Highway SDU Headroom in accordance with Sections 25.8.7 and 25.8.8 of Attachment S of the NYISO OATT.

Developer(s) or Interconnection Customer(s) of the subsequent project(s) will make a lump sum payment(s) to the constructing TO(s) proportional to the electrical use of the Headroom in the account by the Developers' or Interconnection Customers' project(s). Such payments will be made as soon as the cost responsibilities of the subsequent Developer(s) or Interconnection Customer(s) are determined in accordance with Attachment S of the NYISO OATT.

Payments to the constructing TO(s) will be based on the depreciated amount of the Highway SDU in the constructing Transmission Owner(s)' accounting records. The constructing TO(s) will adjust its (their) revenue requirement(s) to account for the payments received from the subsequent Developer(s) or Interconnection Customer(s) to lower the HFC charged to LSEs going forward.

The NYISO will credit the subsequent Developer(s) or Interconnection Customer(s) with any revenues derived from the monetization of Incremental TCCs created by the Highway SDU in proportion to the use of Headroom by the Developers' or Interconnection Customers' project(s). Credits to the LSEs from sales of Incremental TCCs will be reduced proportionately.

8.11. Charges for Intermittent Power Resource Forecasting Service

The NYISO will charge each Intermittent Power Resource, except for Intermittent Power Resources in a DER Aggregation, that depends on wind or solar energy as its fuel that is interconnected in the New York Control Area in order to provide Energy to the LBMP Market or bilaterally to a Load internal or external to the NYCA, pursuant to the NYISO Service Tariff or the NYISO OATT, and that has entered commercial operation for forecasting service pursuant to Rate Schedule 7 of the NYISO Services Tariff, provided however no charge will be assessed against any Intermittent Power Resource in commercial operation as

of January 1, 2002 with nameplate capacity of 12 MWs or fewer.

The NYISO will calculate forecasting charge which will include a fixed component and a variable component that varies by the nameplate capacity of the Intermittent Power Resource subject to this charge (“Forecasting Service Charge”). Such charge will be based upon the costs the NYISO incurs in producing a forecast of the expected generation output of each Intermittent Power resource subject to this charge.

Intermittent Power Resource will pay the Forecasting Service Charge each month as illustrated formulaically in Appendix M of this manual.

8.12. Reliability Must Run (RMR) Charge Recovery

This section describes the NYISO’s cost recovery process, as provided for under Rate Schedule 14 (Section 6.14) of the NYISO OATT, for costs related to each Reliability Must Run (RMR) contract to address reliability needs identified by the NYISO. The allocation of costs associated with RMR are illustrated formulaically in Appendix M of this manual.

8.13. Recovery for Costs for Demand Reductions Associated with DER Aggregations

This section describes the NYISO’s cost recovery process for payments to DER Aggregations for demand reductions, as described in OATT Attachment R - Cost Allocation and Measurement and Verification Methodologies for Demand Reductions by Distributed Energy Resources in a DER Aggregation (Section 24) of the NYISO OATT. The allocation of costs associated with payments to DER Aggregation for demand reductions are illustrated formulaically in Appendix M of this manual.

9. Transmission Congestion Contract Settlements

The amount paid or charged to Primary Holders of Transmission Congestion Contracts (TCCs) is computed as the product of (a) the nominal value of the TCC, in megawatts (MW), and (b) the Congestion Component of the LBMP at the Point of Withdrawal for the respective TCC minus the Congestion Component of the LBMP at the Point of Injection for the respective TCC.

The NYISO pays or charges Primary Holders of TCCs for Congestion Rents from revenues collected from (i) Congestion Rents, (ii) Outage/Return-to-Service Congestion Rent Shortfall Charges and Uprate/Derate Congestion Rent Shortfall Charges, and (iii) Net Congestion Rents.

The Congestion payment to Primary TCC Holders is illustrated formulaically in Appendix L of this manual.

10. Transmission Owner Settlements

10.1. Net DAM Congestion Rent Balancing

10.1.1. Calculation and Allocation of Net Congestion Rents

10.1.1.1. Calculation of Net Congestion Rents

For each hour of the Day-Ahead Market (DAM), the NYISO settles all Congestion settlements related to the DAM, which include (i) Congestion Rent charges or payments for Energy Transactions in the DAM and Bilateral Transactions scheduled in the DAM; (ii) Congestion payments or charges to Primary Holders of Transmission Congestion Contracts (TCCs); (iii) Outage/Return-to-Service Congestion Rent Shortfall Charges and Uprate/Derate Congestion Rent Shortfall Charges, summed for all Transmission Owners over the hour, as described in Section 10.1.1.3 of this manual; and (iv) Outage/Return-to-Service Congestion Rent Surplus Payments and Uprate/Derate Congestion Rent Surplus Payments, summed for all Transmission Owners over the hour, as described in Section 10.1.1.3 of this manual.

For each hour of the DAM, the NYISO calculates Net Congestion Rents as Congestion Rent charges or payments for Energy Transactions scheduled in the DAM plus Congestion Rent charges or payments for Bilateral Transactions scheduled in the DAM minus Congestion payments or charges to Primary Holders of TCCs minus Outage/Return-to-Service Congestion Rent Shortfall Charges and Uprate/Derate Congestion Rent Shortfall Charges minus Outage/Return-to-Service Congestion Rent Surplus Payments and Uprate/Derate Congestion Rent Surplus Payments.

10.1.1.2. Allocation of Net Congestion Rents

Hourly Net Congestion Rents are summed over the month and allocated to the Transmission Owners. Positive monthly Net Congestion Rent results in payments to the Transmission Owners, whereas negative balances result in charges to the Transmission Owners. The monthly Net Congestion Rent allocated to each Transmission Owner is computed as the product of (A) the monthly Net Congestion Rent, derived as the sum of the hourly Net Congestion Rents over the month and (B) the quotient of (a) the sum of (i) the Transmission Owner's one-month portion of the revenue imputed to the Direct Sale or the sale in any Centralized TCC Auction sub-auction of Original Residual TCCs that are valid in that month; (ii) sum of the one-month portion of the revenue the Transmission Owner has received as payment for the Direct Sale of ETCNL or for its ETCNL released in the Centralized TCC Auction sub-auction held for TCCs valid for that month; (iii) the one-month portion of the Net Auction Revenues the Transmission Owner has received in Centralized TCC Auction sub-auctions and Reconfiguration Auctions held for TCCs valid for that month, exclusive of any revenue from the sale of Original Residual TCCs; and (iv) the one-month portion of the

imputed value of Grandfathered TCCs and Grandfathered Rights, valued at their Market Clearing Prices in the Reconfiguration Auction for that month (or one-sixth of the average Market Clearing Price in stage 1 rounds in the 6-month sub-auction of the last Centralized TCC Auction if no Reconfiguration Auction was held for that month), provided that the Transmission Owner is the selling party and the Existing Transmission Agreement related to each Grandfathered TCC and Grandfathered Right remains valid in that month; divided by (b) the total revenues for all Transmission Owners received from the sources detailed above in the dividend of this equation for the month. Refer to Section 20.2.5 of the OATT Attachment N for further detail on the computation of the aforementioned variables.

The determination and allocation of Net Congestion Rent is illustrated formulaically in Appendix L of this manual.

10.1.1.3. Charges and Payments to Transmission Owners for DAM Outages and Returns-to-Service

For each hour of the DAM, the NYISO identifies all constraints that are binding in the Power Flow solution for the final schedules for the hour. For each hour, the NYISO computes the financial impact of each binding constraint and determines whether the constraints are the result of DAM transmission facility outages, returns-to-service, uprates, and/or derates. The NYISO determines to what extent such DAM transmission facility outages, returns-to-service, uprates, and/or derates lead to the creation of the binding constraints and associated Congestion Rent Shortfalls and/or Surpluses. The NYISO charges Transmission Owners for the Congestions Rent Shortfalls and pays Transmission Owners for the Congestion Rent Surpluses attributable to DAM transmission facility outages, returns-to-service, uprates, and derates of the transmission facilities for which they are responsible.

The determination of Congestion Rent Shortfalls and Surpluses attributable to DAM transmission facility outages, returns-to-service, uprates, and derates and the allocation of such Congestion Rent Shortfalls and Surpluses to Transmission Owners are described in detail and formulaically in Section 20.2.4 of Open Access Transmission Tariff (OATT) Attachment N of this manual.

10.1.1.4. Process for Finalization of Day-Ahead Congestion Shortfall Settlements

10.1.1.4.1. Initial Invoice to be Based on Estimate

The NYISO will initially invoice DAM Shortfall Settlements using estimate values, in accordance with the NYISO tariffs. The remainder of this Section describes the process for truing up this initial estimate according to the tariff.

10.1.1.4.2. Completion of DAM Shortfall Settlement Calculations

The NYISO will complete the calculation of TOs' DAM Shortfall Settlements for a given service month consistent with Sections 20.2.4 and 20.2.5 of Attachment N of the NYISO's Open Access Transmission Tariff

and Sections 17.5.2.4 and 17.5.2.5 of Attachment B of its Market Administration and Control Area Services Tariff. The NYISO will complete these settlement calculations and identify the adjustments on the 4 month true-up invoice for the service month.

10.1.1.4.3. Transmission Owner Review of DAM Equipment Outage Responsibility

As soon as is reasonably practical at the conclusion of a service month, the NYISO will provide a report of TO responsibility for those equipment outages that affect the Day-Ahead Market ("DAM equipment outages") for review by the TOs. TOs will agree to or modify the outage responsibility assignments in accordance with NYISO tariffs, NYISO Procedures, and the process described below.

Each TO will provide the NYISO with one or more email addresses for correspondence concerning DAM equipment outage review and responsibility reassignment. A TO identified in the NYISO report of Transmission Owner responsibility for DAM equipment outages may request a change by modifying the report for the affected outages. The TO must provide the modified report to the NYISO by email to the DCR Settlement project mailbox (DCRSettlement@NYISO.com) AND must:

- For changes to a specific TO, reply to the NYISO email and, at a minimum, copy the other TO(s) referenced in the requested outage change
- For changes to shared responsibility (e.g. for an external event or NYISO directed outage), reply to the NYISO email and copy ALL Transmission Owners since all will be affected by the requested change

The sum of partial responsibilities for outage responsibility modification must total 100%.

Responsibility reassignment requests will be presented not later than 15 business days from receipt of the DAM equipment outage report.

The TO(s) referenced in the requested outage responsibility reassignment change will confer with the requesting TO to come to a resolution and notify the NYISO of the resolution within 10 business days of the outage responsibility reassignment request. If the TO(s) referenced in the requested change acknowledges and accepts the change, it will be incorporated into the allocation of DAM Congestion Residual.

If the TO requests shared outage responsibility reassignment (e.g., for an outage caused by an external event), then the responsibility reassignment will be incorporated into the DAM Congestion Residual allocation, unless another TO objects within 10 business days of the request.

Failure of a TO to comply with the procedures and deadlines set forth above for requesting or objecting to proposed responsibility assignments or reassignments will result in it (the TO) being deemed not to dispute the proposed assignment or reassignment.

Should the above process fail to resolve any DAM equipment outage responsibility reassignment, either because a TO identified to receive responsibility reassignment fails to accept the reassignment, or any TO

objects to reassignment as a shared outage responsibility for an outage caused by an external event or otherwise, the NYISO will inform all Transmission Owners of the disputed responsibility reassignment and will moderate a discussion of the dispute. Failing a resolution from this discussion, the provisions of the tariffs and NYISO Procedures will apply to the allocation of responsibility.

10.1.1.4.4. Transmission Owner Review of Invoices

The NYISO will present the Transmission Owners with reports of the invoice adjustments related to DAM Shortfall Settlements, excluding interest charges, and the supporting calculations. These reports will be made available as soon as is reasonably practical, but no later than the time at which the service month 4 month true-up invoice that presents these adjustments is made available.

Prior to the NYISO's issuance of the service month 4 month true-up invoice, a TO may advise the NYISO of any portion or portions of a DAM Shortfall Settlement that it believes to be incorrect. Notice of the potential errors will be submitted in writing, clearly identified as such, stating the basis for the concern and providing any applicable supporting documentation. The NYISO will review the potential errors submitted by Transmission Owners and make any necessary changes or corrections to DAM Shortfall Settlements as soon as reasonably practicable. The NYISO will then provide the corrected DAM Shortfall Settlements to Transmission Owners for an additional review. Notwithstanding the above, once the 4 month true-up invoice for the service month presenting DAM Shortfall Settlement adjustments is issued, any challenge will be made in accordance with the provisions of section 7.4 of the NYISO's Market Administration and Control Area Services Tariff.

10.1.1.4.5. Inclusion in Regular Monthly Invoice

Following the review period described above, and at such time as the NYISO determines that no further corrections are necessary, the NYISO will calculate and apply interest to the DAM Shortfall Settlements for a given service month and include them as line-item manual adjustments in the 4-month service month true-up settlement invoice to be posted.

10.2. NYPA Transmission Adjustment Charge (NTAC)

Pursuant to Section 7.6 of this manual, the NYISO charges an NTAC to LSEs, Customers scheduling Export or Wheel Through Transactions not sinking in the New England Control Area and withdrawals by Energy Storage Resources when not providing a service or Aggregations containing one or more Energy Storage Resources. A monthly payment is made to NYPA of the NTAC collected through this charge.

The calculation of the payment of NTAC collected from LSEs and Transmission Customers to NYPA is illustrated formulaically in Appendix K of this manual.

10.3. Transmission Service Charge MWh Reporting to Transmission Providers

10.3.1. External Transaction TSC MWh Reporting

Export and Wheel through transaction customers will pay a TSC charge directly to the Transmission Owner as described in Appendix A. These withdrawals will be calculated by the NYISO and reported to both the generator and Transmission Owner in their respective settlement statements and reports.

10.3.2. Energy Storage Resource Storage Withdrawals TSC MWh Reporting

Energy Storage Resources (ESR) and Aggregations containing one or more Energy Storage Resources will pay a TSC charge directly to the Transmission Owner in whose Transmission District the Energy Storage Resource is located for Actual Energy Withdrawals by the Energy Storage Resource when it is not providing a service as described in Appendix A. These withdrawals will be calculated by the NYISO and reported to both the generator and Transmission Owner in their respective settlement statements and reports.

Appendix A. Information regarding TSCs

A Transmission Service Charge (TSC) is applied by the eight NYCA Transmission Owners on all external withdrawal transactions (exports and wheel-throughs) to recover a portion of the cost of maintaining the transmission system; owned by the Transmission Owner except destinations within the New England Control Area provided that the conditions listed in Section 2.7.2.1.4 of the Tariff are satisfied. The NYISO is responsible for reporting the MWh values for each external withdrawal transaction that flows between the NYISO and a corresponding control area. The collection of TSC charges are the responsibility of the Transmission Owner and are not administered through the NYISO's settlements process.

Energy Storage Resources (ESR) will also pay a TSC charge directly to the Transmission Owner in whose Transmission District the Energy Storage Resource is located for Actual Energy Withdrawals by the Energy Storage Resource when it is not providing a service. Aggregations containing one or more Energy Storage Resources will pay a TSC directly to the Transmission Owner in whose Transmission District the Aggregation is located when (i) the Aggregation is not providing a service, and (ii) the sum of the Aggregation's Energy injections and Demand Reductions, less the Aggregation's Energy withdrawals, is negative.

An Energy Storage Resource, and an Aggregation containing one or more Energy Storage Resources, is providing a "service" when it is withdrawing Energy if it also: (1) receives a Real-Time Market schedule for Operating Reserves; or (2) receives a Real-Time Market schedule for Regulation Service; or (3) is a qualified Supplier of Voltage Support Service to the ISO in accordance with Section 15.2 of the ISO Services Tariff; or (4) is dispatched by the ISO as Out-of-Merit to meet NYCA or local system reliability in the same hour.

An Energy Storage Resource that participates as a Co-located Storage Resource will only pay a TSC for net Actual Energy Withdrawals by the combined Co-located Storage Resources. An Energy Storage Resource that participates as a Co-located Storage Resource will not pay a TSC when it receives charging Energy from its co-located Intermittent Power Resource behind the Co-located Storage Resources' shared Point of Injection/Point of Withdrawal.

When an Energy Storage Resource is subjected to a TSC, the TSC shall be payable regardless of whether the withdrawals are scheduled or unscheduled. The NYISO will determine the amount of Actual Energy Withdrawals subject to the TSC charge.

Appendix B. Supplier Energy Settlement Formulae

B.1. Day-Ahead Energy Settlements for Generators and Virtual Supply

$$\sum_{h=1}^N \{[(EH_{gh}^{DA} - TH_{gh}^{DA}) \times (LBMPe_{gh}^{DA} + LBMPl_{gh}^{DA} - LBMPc_{gh}^{DA})] \times 1 \text{ hour}\}$$

Where:

- N : Number of hours in the Dispatch Day
- EH_{gh}^{DA} : Energy scheduled Day-Ahead to be produced or consumed by Generator g in hour h expressed in terms of MW;
- TH_{gh}^{DA} : Energy scheduled to support Bilateral Transactions Day-Ahead to be produced by Generator g in hour h expressed in terms of MW;
- $LBMPe_{gh}^{DA}$: Energy component of the Day-Ahead LBMP at Generator g 's bus in hour h expressed in \$/MWh;
- $LBMPl_{gh}^{DA}$: Losses component of the Day-Ahead LBMP at Generator g 's bus in hour h expressed in \$/MWh;
- $LBMPc_{gh}^{DA}$: Congestion component of the Day-Ahead LBMP at Generator g 's bus in hour h expressed in \$/MWh;

B.2. Real-Time, Balancing Energy Settlements for Generators other than Limited Energy Storage Resources

$$\sum_{h=1}^N \{[(EIWB_{gi}^{RT} - EH_{gh}^{DA} - (TH_{gh}^{DA} + TH_{gi}^{RT}) + EDRB_{gi}^{RT}) \times (LBMPe_{gi}^{RT} + LBMPl_{gi}^{RT} - LBMPc_{gi}^{RT})] \times [s_i^{RT} \div 3600 \text{ seconds}]\}$$

Where:

- N : Number of hours in the Dispatch Day
- s_i^{RT} : Length of RTD interval i , expressed in seconds
- EH_{gh}^{DA} : Energy scheduled Day-Ahead to be produced or consumed by Generator g in hour h containing RTD interval i , expressed in terms of MW;
- TH_{gh}^{DA} : Energy scheduled to support Bilateral Transactions Day-Ahead to be produced by Generator g in hour h containing RTD interval i , expressed in terms of MW;
- TH_{gi}^{RT} : Energy scheduled after the DAM to support Bilateral Transactions to be produced by Generator g in RTD interval i , expressed in terms of MW;

- $LBMPe_{gi}^{RT}$: Energy component of the Real-Time LBMP at Generator g 's bus in RTD interval i , expressed in \$/MWh;
- $LBMPl_{gi}^{RT}$: Losses component of the Real-Time LBMP at Generator g 's bus in RTD interval i , expressed in \$/MWh;
- $LBMPc_{gi}^{RT}$: Congestion component of the Real-Time LBMP at Generator g 's bus in RTD interval i , expressed in \$/MWh;
- $EIWB_{gi}^{RT}$: Energy settlement megawatt basis for energy injections and withdrawals for Generator g in RTD interval i , expressed in terms of megawatts, as determined below;
- $EIWB_{gi}^{RT}$ = Generator g 's actual megawatt injections and withdrawals when:
 - ✧ RTD interval i is either a Reserve, Large Event, or Max-Gen pick-up interval or one of the three intervals following the pick-up interval;
 - ✧ Generator g is a Pump Storage unit and is not scheduled to provide Regulation Service in RTD interval i ; or
 - ✧ Generator g is out of merit for reliability reasons (i.e., OOM Type = 1, 2, 4, 23, 24, 25, 26, 27, 40, 50, 80, and 81), except for instances when out of merit as an Energy Limited Resource (i.e., OOM Type 21), as indicated in the Table 2 in Appendix C;
 - ✧ Generator g is classified as a PURPA unit and has offered its Energy to the ISO in a given interval not using the ISO-committed Flexible or Self-Committed Flexible bid mode.
 - ✧ Generator g is not scheduled to provide regulation service in the real time market and the Real-Time LBMP for RTD interval i is negative.
 - ✧ Generator g that uses Wind or Solar as its fuel source for which the ISO has not imposed a Wind and Solar Output Limit in the given RTD interval.
 - $EIWB_{gi}^{RT}$ = the lesser of Generator g 's actual megawatt injections and withdrawals and its RTD Ramped Base Point MW over RTD interval i when Generator g is out of merit for operator intervention/modify UOL or operator intervention/modify both, as detailed in the Table 5 in Appendix C (i.e., OOM Type = 31 or 33);
 - $EIWB_{gi}^{RT}$ = the lesser of Generator g 's actual megawatt injections and withdrawals and its RTD Average AGC Base Point MW over RTD interval i when Generator g is scheduled to provide Regulation Service in RTD interval i ;
 - $EIWB_{gi}^{RT}$ = the lesser of (a) Generator g 's actual megawatt injections and withdrawals over RTD interval i and either: (b) Generator g is scheduled to inject, the Generator g 's RTD Ramped Base Point over RTD interval i plus 3% of its Upper Operating Limit [or zero when the RTD Ramped Base Point is 0 MW] or (c) if the Generator is scheduled to withdraw, the Generator g 's RTD Ramped Base Point over RTD interval i plus 3% of the absolute value of its Lower Operating Limit when:
 - ✧ Generator g is out of merit for reliability reasons as an Energy Limited Resource (i.e., OOM Type 21) per the Table 2 in Appendix C; or

✧ Under any other conditions not specifically identified above.

$EDRB_{gi}^{RT}$: Energy demand reductions basis for Generator g in RTD interval i , expressed in terms of megawatts;

- $EDRB_{gi}^{RT}$ = Generator g 's actual demand reductions when:
 - ✧ RTD interval i is either a Reserve, Large Event, or Max-Gen pick-up interval or one of the three intervals following the pick-up interval;
 - ✧ Generator g is out of merit for reliability reasons (i.e., OOM Type = 1, 2, 4, 23, 24, 25, 26, 27, 40, 50, 80, and 81), except for instances when out of merit as an Energy Limited Resource (i.e., OOM Type 21), as indicated in the Table 2 in Appendix C;
 - ✧ Generator g is not scheduled to provide regulation service in the real time market and the Real-Time LBMP for RTD interval i is negative.
- $EDRB_{gi}^{RT}$ = Actual demand reductions shall be set to zero when the real time Real-Time LBMP calculated in that RTD interval for the applicable Transmission Node is less than the Monthly Net Benefit Threshold price, otherwise:
 - $EDRB_{gi}^{RT}$ = the lesser of Generator g 's actual demand reductions and the maximum of zero or its RTD Ramped Base Point MW minus actual injections and withdrawals over RTD interval i when Generator g is out of merit for operator intervention/modify UOL or operator intervention/modify both, as detailed in the Table 5 in Appendix C (i.e., OOM Type = 31 or 33);
 - $EDRB_{gi}^{RT}$ = the lesser of Generator g 's actual demand reductions and the maximum of zero or RTD Average AGC Base Point MW minus actual injections and withdrawals over RTD interval i when Generator g is scheduled to provide Regulation Service in RTD interval i .
 - $EDRB_{gi}^{RT}$ = the lesser of (a) Generator g 's actual demand reductions over RTD interval i and either: (b) Generator g is scheduled to inject, the maximum of zero or Generator g 's RTD Ramped Base Point over RTD interval i plus 3% of its Upper Operating Limit [or zero when the RTD Ramped Base Point is 0 MW] minus actual injections and withdrawals or (c) if the Generator is scheduled to withdraw, the maximum of zero or the Generator g 's RTD Ramped Base Point over RTD interval i plus 3% of the absolute value of its Lower Operating Limit when:
 - ✧ Generator g is out of merit for reliability reasons as an Energy Limited Resource (i.e., OOM Type 21) per the Table 2 in Appendix C; or
 - ✧ Under any other conditions not specifically identified above.

B.3. Real-Time, Balancing Energy Settlements for Limited Energy Storage Resources

$$\sum_{h=1}^N \{(EInjections_h - EWithdrawals_h) \times LBMP_h\}$$

Where:

- N : Number of hours in the Dispatch Day
- $EInjections_h$: Energy injected by the Limited Energy Storage Resource in hour h
- $EWithdrawals_h$: Energy withdrawn by the Limited Energy Storage Resource in hour h
- $LBMP_h$: Time-weighted average LBMP in hour h calculated for the location of the Limited Energy Storage Resource

B.4. Day-Ahead Energy Settlements for LBMP Market Energy Imports

$$\sum_{h=1}^N \{[-TH_{th}^{DA} \times (LBMPe_{pth}^{DA} + LBMPl_{pth}^{DA} - LBMPc_{pth}^{DA})] \times 1 \text{ hour}\}$$

Where:

- N : Number of hours in the Dispatch Day
- TH_{th}^{DA} : LBMP Market Energy Import Transaction megawatts scheduled Day-Ahead to be imported through Transaction t in hour h expressed in terms of MW;
- $LBMPe_{pth}^{DA}$: Energy component of the Day-Ahead LBMP at Proxy Bus p , scheduled as the Point of Injection for LBMP Market Energy Import Transaction t , in hour h expressed in \$/MWh;
- $LBMPl_{pth}^{DA}$: Losses component of the Day-Ahead LBMP at Proxy Bus p , scheduled as the Point of Injection for LBMP Market Energy Import Transaction t , in hour h expressed in \$/MWh;
- $LBMPc_{pth}^{DA}$: Congestion component of the Day-Ahead LBMP at Proxy Bus p , scheduled as the Point of Injection for LBMP Market Energy Import Transaction t , in hour h expressed in \$/MWh;

B.5. Real-Time, Balancing Energy Settlements for LBMP Market Energy Imports

$$\sum_{h=1}^N \{[-1(TH_{ti}^{RT} - TH_{th}^{DA}) \times (LBMPe_{pti}^{RT} + LBMPl_{pti}^{RT} - LBMPc_{pti}^{RT})] \times [s_i^{RT} \div 3600 \text{ seconds}]\}$$

Where:

- N : Number of RTD intervals i in the day;
- s_i^{RT} : Length of RTD interval i , expressed in seconds;

- TH_{th}^{DA} : LBMP Market Energy Import Transaction megawatts scheduled Day-Ahead to be imported through Transaction t in hour h containing RTD interval i , expressed in terms of MW;
- TH_{ti}^{RT} : LBMP Market Energy Import Transaction megawatts scheduled in RTD interval i to be imported through Transaction t , expressed in terms of MW;
- $LBMPe_{pti}^{RT}$: Energy component of the Real-Time LBMP at Proxy Bus p , scheduled as the Point of Injection for LBMP Market Energy Import Transaction t , in RTD interval i , expressed in \$/MW;
- $LBMPl_{pti}^{RT}$: Losses component of the Real-Time LBMP at Proxy Bus p , scheduled as the Point of Injection for LBMP Market Energy Import Transaction t , in RTD interval i , expressed in \$/MW;
- $LBMPc_{pti}^{RT}$: Congestion component of the Real-Time LBMP at Proxy Bus p , scheduled as the Point of Injection for LBMP Market Energy Import Transaction t , in RTD interval i , expressed in \$/MW.

B.6. Financial Impact Charge (FIC) for LBMP Market Energy Imports Failing the NYISO Check-out Process

If Transaction Check -out Failure under MP Control,

$$\sum_{i=1}^N \{[(TH_{ti}^{RTC} - TH_{ti}^{RT}) \times (s_i^{RT} \div 3600 \text{ seconds})] \times \max[LBMPc_{porti}^{RT}, 0]\}$$

Otherwise \$0.

Where:

- N : Number of RTD intervals i in the day;
- s_i^{RT} : Length of RTD interval i , expressed in hours;
- TH_{ti}^{RTC} : LBMP Energy Import Transaction megawatts scheduled by RTC₁₅ for hourly transactions and Rolling RTC for intra-hourly transactions containing RTD interval i to be imported through Transaction t , expressed in terms of MW;
- TH_{ti}^{RT} : LBMP Energy Import Transaction megawatts scheduled in RTD interval i to be imported through Transaction t , expressed in terms of MW;
- $LBMPc_{porti}^{RT}$: Congestion component of the Real-Time LBMP at Proxy Generator Bus por , scheduled as the Point of Receipt for LBMP Energy Import Transaction t , in RTD interval i , expressed in \$/MW;

B.7. Incentive payment for Day-Ahead Demand Reduction Providers

$$\sum_{h=1}^N \{ \min(DRR_{rh}^{RT}, DRH_{rh}^{DA} \times 1 \text{ hour}) \times (LBMPe_{bh}^{DA} + LBMPl_{bh}^{DA} - LBMPc_{bh}^{DA}) \}$$

Where:

- N : Number of hours in the Dispatch Day
- DRH_{rh}^{DA} : Demand Reduction scheduled Day-Ahead to be produced by Demand Response Providers' Demand Side Resources r in hour h expressed in terms of MW;
- DRR_{rh}^{RT} : Demand Reduction produced by Demand Response Providers' Demand Side Resources r in hour h , expressed in terms of megawatt hours;
- $LBMPe_{bh}^{DA}$: Energy component of the Day-Ahead LBMP at Demand Side Resource r 's bus b in hour h expressed in \$/MWh;
- $LBMPl_{bh}^{DA}$: Losses component of the Day-Ahead LBMP at Demand Side Resource r 's bus b in hour h expressed in \$/MWh;
- $LBMPc_{bh}^{DA}$: Congestion component of the Day-Ahead LBMP at Demand Side Resource r 's bus b in hour h expressed in \$/MWh;

B.8. Demand Reduction Imbalance Charge to Demand Reduction Providers and LSEs

If the invoice version is version 1 (i.e., the initial monthly invoicing of a service month) and no Demand Reduction megawatt hour data has been provided by the MSE before the initial monthly invoice of the service month, then the Demand Reduction Imbalance Charge for the Demand Reduction Provider is \$0; otherwise, in instances where the Demand Reduction Provider is also the LSE providing Energy service to the Demand Side Resource(s) scheduled to produce the Demand Reduction:

$$\sum_{h=1}^N \left\{ \left[\max(\min\{DRR_{rh}^{RT}, DRH_{rh}^{DA} \times 1 \text{ hour}\}, 0) - (DRH_{rh}^{DA} \times 1 \text{ hour}) \right] \right. \\ \left. \times \max \left[\sum_{i=1}^n (\{LBMPe_{ri}^{RT} + LBMPl_{ri}^{RT} - LBMPc_{ri}^{RT}\} \times \{s_i^{RT} \div 3600 \text{ seconds}\}), (LBMPe_{rh}^{DA} \right. \right. \\ \left. \left. + LBMPl_{rh}^{DA} - LBMPc_{rh}^{DA}) \right] \right\}$$

In instances where the Demand Reduction Provider is not the LSE providing Energy service to the Demand Side Resource(s) scheduled to produce the Demand Reduction, the LSE providing Energy service to the Demand Side Resource(s) is charged as follows:

$$\sum_{h=1}^N \{ [\max(\min\{DRR_{rh}^{RT}, DRH_{rh}^{DA} \times 1 \text{ hour}\}, 0) - (DRH_{rh}^{DA} \times 1 \text{ hour})] \\ \times (LBMPe_{rh}^{DA} + LBMPl_{rh}^{DA} - LBMPc_{rh}^{DA}) \}$$

and the Demand Reduction Provider is also charged as follows:

$$\sum_{h=1}^N \left\{ \left((\max\{\min[DRR_{rh}^{RT}, DRH_{rh}^{DA} \times 1 \text{ hour}], 0\} - \{DRH_{rh}^{DA} \times 1 \text{ hour}\}) \right. \right. \\ \left. \times \max \left(\sum_{i=1}^n \{ [LBMPe_{ri}^{RT} + LBMPl_{ri}^{RT} - LBMPc_{ri}^{RT}] \times [s_i^{RT} \div 3600 \text{ seconds}] \}, \{ LBMPe_{rh}^{DA} \right. \right. \\ \left. \left. + LBMPl_{rh}^{DA} - LBMPc_{rh}^{DA} \right) \right\} \\ - \left[(\max\{\min[DRR_{rh}^{RT}, DRH_{rh}^{DA} \times 1 \text{ hour}], 0\} - \{DRH_{rh}^{DA} \times 1 \text{ hour}\}) \right] \\ \times (LBMPe_{rh}^{DA} + LBMPl_{rh}^{DA} - LBMPc_{rh}^{DA}) \}$$

Where:

- N : Number of hours in the Dispatch Day
- n : Number of RTD intervals in hour h ,
- s_i^{RT} : Length of RTD interval i , expressed in seconds;
- DRH_{rh}^{DA} : Demand Reduction scheduled Day-Ahead to be produced by Demand Response Providers' Demand Side Resources r in hour h , expressed in terms of MW;
- DRR_{rh}^{RT} : Demand Reduction produced by Demand Response Providers' Demand Side Resources r in hour h , expressed in terms of MW;
- $LBMPe_{rh}^{DA}$: Energy component of the Day-Ahead LBMP at Demand Side Resource r 's bus in hour h , expressed in \$/MWh;
- $LBMPl_{rh}^{DA}$: Losses component of the Day-Ahead LBMP at Demand Side Resource r 's bus in hour h , expressed in \$/MWh;
- $LBMPc_{rh}^{DA}$: Congestion component of the Day-Ahead LBMP at Demand Side Resource r 's bus in hour h , expressed in \$/MWh;
- $LBMPe_{ri}^{RT}$: Energy component of the Real-Time LBMP at Demand Side Resource r 's bus in RTD interval i , expressed in \$/MWh;
- $LBMPl_{ri}^{RT}$: Losses component of the Real-Time LBMP at Demand Side Resource r 's bus in RTD interval i , expressed in \$/MWh;
- $LBMPc_{ri}^{RT}$: Congestion component of the Real-Time LBMP at Demand Side Resource r 's bus in RTD interval i , expressed in \$/MWh;

B.9. Real-Time, Balancing Energy Settlements for Virtual Supply

$$\sum_{h=1}^N \{[(EB_{gi}^{RT} - EH_{gh}^{DA}) \times (LBMPe_{gi}^{RT} + LBMPl_{gi}^{RT} - LBMPc_{gi}^{RT})] \times [s_i^{RT} \div 3600 \text{ seconds}]\}$$

Where:

- N : Number of hours in the Dispatch Day
- s_i^{RT} : Length of RTD interval i , expressed in seconds
- EH_{gh}^{DA} : Energy scheduled Day-Ahead to be produced by Virtual Supply bus g in hour h containing RTD interval i , expressed in terms of MW;
- $LBMPe_{gi}^{RT}$: Energy component of the Real-Time LBMP at Virtual Supply bus g 's bus in RTD interval i , expressed in \$/MWh;
- $LBMPl_{gi}^{RT}$: Losses component of the Real-Time LBMP at Virtual Supply bus g 's bus in RTD interval i , expressed in \$/MWh;
- $LBMPc_{gi}^{RT}$: Congestion component of the Real-Time LBMP at Virtual Supply bus g 's bus in RTD interval i , expressed in \$/MWh;
- EB_{gi}^{RT} : Energy settlement megawatt basis for Virtual Supply bus g in RTD interval i , expressed in terms of megawatts;

Appendix C. Out of Merit Operation Impacting Settlements

Table 0.1 All Out of Merit Types

OOM Type	OOM Description
1	Committed for ISO Reliability
2	OOM for TO Reliability
3	OOM Generator Request
4	OOM for Reserves
21	ISO Energy Limited Res
23	ISO Voltage Support
24	TO Voltage Support
25	OOM for Testing
26	ISO Com Failure
27	TO Com Failure
28	Gen Request/Modify UOL
29	Gen Request/Modify MinGen
30	Gen Request/Modify both
31	Ops Intervene/Modify UOL
32	Ops Intervene/Modify MinGen
33	Ops Intervene/Modify both
40	NYISO Gen Audit
50	Start-Up/Shut Down
60	SYS OOM NYISO SCR/EDRP
61	SYS OOM CE TDRP
80	MWH – OOM for ISO Reliability
81	MWH – OOM for TO Reliability
82	MWH – OOM for Gen Request
90	CSR POI Scheduling Limit – OOM for ISO Reliability
91	CSR POI Scheduling Limit – OOM for TO Reliability
92	CSR POI Scheduling Limit – OOM Generator Request

Table 0.2 Out of Merit for Reliability

OOM Type	Reason for OOM
1	Committed for ISO Reliability
2	OOM for TO Reliability
4	OOM for Reserves
21	ISO Energy Limited Res
23	ISO Voltage Support
24	TO Voltage Support
25	OOM for Testing
26	ISO Com Failure
27	TO Com Failure
40	NYISO Gen Audit
50	Start-Up/Shut Down
80	MWH – OOM for ISO Reliability
81	MWH – OOM for TO Reliability
90	CSR POI Scheduling Limit – OOM for ISO Reliability
91	CSR POI Scheduling Limit – OOM for TO Reliability

Table 0.3 Out of Merit for Local Reliability

OOM Type	Reason for OOM
2	OOM for TO Reliability
24	TO Voltage Support
81	MWH – OOM for TO Reliability
91	CSR POI Scheduling Limit – OOM for TO Reliability

Table 0.4 Out of Merit for Voltage Support

OOM Type	Reason for OOM
23	ISO Voltage Support
24	TO Voltage Support

Table 0.5 Out of Merit Due to Operator Intervention

OOM Type	Reason for OOM
31	Ops Intervene/Modify UOL
32	Ops Intervene/Modify MinGen
33	Ops Intervene/Modify both

Table 0.6 Out of Merit with Gen Increase

OOM Type	Reason for OOM
29	Gen Request/Modify MinGen

30	Gen Request/Modify both
32	Ops Intervene/Modify MinGen
33	Ops Intervene/Modify both

Table 0.7 Out of Merit Due to Generator Request

OOM Type	Reason for OOM
28	Gen Request/Modify UOL
29	Gen Request/Modify MinGen
30	Gen Request/Modify both
82	MWH – OOM for Gen Request
92	CSR POI Scheduling Limit – OOM Generator Request

Table 0.8 Items Included in OOM 25

DMNC Tests
 VAr Tests
 RATA Tests
 Mill Fineness Checks
 Reheat Intercept/Stop Valve Leakage Tests
 N2 Leakage Tests
 Boiler Efficiency Tests
 GT Monthly Operational Tests
 Particulate Tests
 NOx Tests
 Full Load Fuel Oil Tests
 Control System Performance Tests

Appendix D. Intentionally left blank

Appendix E. Bid Production Cost Guarantee Formulae

E.1. Day-Ahead Bid Production Guarantee (DAM BPCG)

$$\max \left[\sum_{h=1}^N \left\{ \int_{MGH_{gh}^{DA}}^{EH_{gh}^{DA}} C_{gh}^{DA} + MGC_{gh}^{DA} MGH_{gh}^{DA} + SUC_{gh}^{DA} NSUH_{gh}^{DA} - LBMP_{gh}^{DA} EH_{gh}^{DA} - NASR_{gh}^{DA} \right\}, 0 \right]$$

Where:

Supplier_g: Generator *g* or Aggregation *g*;

N: Number of hours in the Day-Ahead Market Day;

EH_{gh}^{DA} : Energy scheduled Day-Ahead to be produced by or withdrawn by Supplier *g*, which is eligible to withdraw Energy, in hour *h* expressed in terms of MWh;

MGH_{gh}^{DA} : Energy scheduled Day-Ahead to be produced as the minimum generation segment by Supplier *g* in hour *h* expressed in terms of MWh;

C_{gh}^{DA} : Incremental Energy Bid cost submitted by Supplier *g*, or when applicable the mitigated Incremental Energy Bid cost curve for Supplier *g*, in the Day-Ahead Market for hour *h* expressed in terms of \$/MWh;

MGC_{gh}^{DA} : Minimum Generation Bid by Supplier *g*, or when applicable the mitigated Minimum Generation Bid for Supplier *g*, for hour *h* in the Day-Ahead Market, expressed in terms of \$/MWh.

If Supplier *g* was committed in the Day-Ahead Market, or in the Real-Time Market via Supplemental Resource Evaluation (SRE), on the day prior to the Dispatch Day and Supplier *g* has not yet completed the minimum run time reflected in the accepted Bid for the hour in which it was scheduled to start on the day before the Dispatch Day (as mitigated, where appropriate), then Supplier *g* will have its minimum generation cost set equal to the revenues received for energy produced at its minimum operating level for purposes of calculating a Day-Ahead Bid Production Cost Guarantee until Supplier *g* completes the minimum run time reflected in the accepted Bid for the hour in which it was scheduled to start on the day before the Dispatch Day;

SUC_{gh}^{DA} : Start-Up Bid by Supplier *g* in hour *h*, or when applicable the mitigated Start-Up Bid for Supplier *g* in hour *h*, in the Day-Ahead Market expressed in terms of \$/start; *provided, however,* that the Start-Up Bid for Supplier *g* in hour *h* or, when applicable, the mitigated Start-Up Bid, for Supplier *g* in hour *h*, may be subject to pro rata reduction in accordance with the rules illustrated formulaically in section E.3 below. Bases for pro rata reduction include, but are not limited to, failure to be scheduled, and to operate in real-time to produce, in each hour, the MWh specified in the accepted Minimum Generation Bid that was submitted for the first hour of Supplier *g*'s Day-Ahead or SRE schedule, and failure to operate for the minimum run time specified in the Bid submitted for the first hour of Supplier *g*'s Day-Ahead or SRE schedule.

If a Supplier *g* was committed in the Day-Ahead Market, or in the Real-Time Market via SRE, on the day prior to the Dispatch Day, and Supplier *g* has not yet completed the minimum run time reflected in the accepted Bid for the hour in which it was

scheduled to start on the day before the Dispatch Day (as mitigated, where appropriate) plus the contiguous hour that follows the conclusion of such minimum run time, then Supplier g will have its Start-Up Bid set to zero for purposes of calculating a Day-Ahead Bid Production Cost Guarantee.

For a long start-up time Supplier (i.e., a Supplier that cannot be scheduled by SCUC to start up in time for the next Dispatch Day) that is committed by the NYISO and runs in real-time, the Start-Up Bid for Supplier g in hour h will be the Supplier's Start-Up Bid, or when applicable the mitigated Start-Up Bid for Supplier g , for the hour (as determined at the point in time in which the NYISO provided notice of the request for start-up);

- $NSUH_{gh}^{DA}$: Number of times Supplier g is scheduled Day-Ahead to start up in hour h ;
- $LBMP_{gh}^{DA}$: Day-Ahead LBMP at Supplier g 's bus in hour h expressed in \$/MWh;
- $NASR_{gh}^{DA}$: Net Ancillary Services revenue, expressed in terms of \$, paid to Supplier g as a result of having been committed to produce Energy for the LBMP Market and/or Ancillary Services Day-Ahead in hour h which is computed as follows:

$$NASR_{gh}^{DA} = VSS_{gh} + (REGCS_{gh}^{DA} - REGCB_{gh}^{DA}) + (OPResS_{gh}^{DA} - OPResB_{gh}^{DA})$$

Where:

- VSS_{gh} : Voltage Support Service payments received for hour h by Supplier g who is not a Supplier of Installed Capacity and has been scheduled to operate in that hour;
- $REGCS_{gh}^{DA}$: Regulation Capacity payments made to Supplier g for all Regulation Capacity scheduled Day-Ahead for hour h
- $REGCB_{gh}^{DA}$: Supplier g 's Day-Ahead Regulation Capacity Bid to provide that amount of Regulation Capacity in hour h ;
- $OPResS_{gh}^{DA}$: Payments made to Supplier g for providing Spinning Reserve and synchronized 30-Minute Reserve in hour h for Day-Ahead commitments to provide such reserves
- $OPResB_{gh}^{DA}$: Supplier g 's Day-Ahead Bid to provide Spinning Reserve and synchronized 30-Minute Reserve in hour h .

E.2. Total Energy Required to be Provided in Order to Avoid Proration of a Generator's Start-Up Costs

$$MinOpMW_{gh} \times n_{gh}$$

Where:

- $MinOpMW_{gh}$: Minimum operating level (in MW) specified by Generator g in its hour h Bid;
- n_{gh} : The last hour that Generator g must operate when started in hour h to complete both its minimum run time and its Day-Ahead schedule calculated as follows:

$$n_{gh} = \max(LastHrDASched_{gh}, LastMinRunHr_{gh})$$

Where:

$LastHrDASched_{gh}$: The last date/hour in a contiguous set of hours in the Dispatch Day, beginning with hour h , in which Generator g is scheduled to operate in the Day-Ahead Market;

$LastMinRunHr_{gh}$: The last date/hour in a contiguous set of hours in which Generator g would need to operate to complete its minimum run time if it starts in hour h .

E.3. Calculation of Prorated Start-Up Cost

$$SubmittedSUC_{gh} \times \left(\sum_{h=s}^{n_{gh}} MinOpEnergy_{ghs} \div TotalMWReq_{gh} \right)$$

Where:

$SubmittedSUC_{gh}$: The Start-Up Bid submitted (as mitigated where appropriate) for Generator g that is scheduled to start in hour h ;

$MinOpEnergy_{ghs}$: the amount of Energy produced during hour h by Generator g during the time required to complete both its minimum run time and its Day-Ahead schedule, if that generator started in hour s calculated as follows:

$$MinOpEnergy_{ghs} = \min(MetActEnergy_{gh}, MinOpMW_{gh})$$

Where:

$MetActEnergy_{gh}$: the metered amount of Energy produced by Generator g during hour h .

$MinOpMW_{gh}$: Minimum operating level (in MW) specified by Generator g in its hour h Bid;

Additional Rules that Apply to the Calculation of Prorated Start-Up Cost

1. For any hour that a Generator is derated below the minimum operating level specified in its accepted Start-Up Bid for reliability, either by the NYISO or at the request of a Transmission Owner, the Generator will receive credit for that hour as if the Generator had produced metered actual MWh equal to its $MinOpMW_{gh}$.
2. A Generator must be scheduled and operate in real-time to produce Energy consistent with the $MinOpMW_{gh}$ specified in the accepted Start-Up Bid for each hour that it is expected to run. These rules do not specify or require any particular bidding construct that must be used to achieve the desired commitment. However, submitting a self-committed Bid may preclude a Generator from receiving a BPCG.
3. This proration logic applies to all Generators committed in the Day Ahead Market or via SRE.

E.4. Formula for Determining Real-Time BPCG for Generators and Aggregations in RTD Intervals Other Than Supplemental Event Intervals

Real-Time Bid Production Cost Guarantee for Supplier g , which is not an Energy Storage Resource or an Aggregation that contains Energy Storage Resource(s) =

$$\text{Max} \left[\left(\sum_{i \in M} \left(\int_{\max(EI_{gi}^{DA}, MGI_{gi}^{RT})}^{\max(EI_{gi}^{RT}, MGI_{gi}^{RT})} C_{gi}^{RT} + MGC_{gi}^{RT} * (MGI_{gi}^{RT} - MGI_{gi}^{DA}) - LBMP_{gi}^{RT} * (EI_{gi}^{RT} - EI_{gi}^{DA}) \right) * \frac{S_i}{3600} \right) - (NASR_{gi}^{TOT} - NASR_{gi}^{DA}) - RRAP_{gi} + RRAC_{gi} + \sum_{j \in L} SUC_{gj}^{RT} * (NSUI_{gj}^{RT} - NSUI_{gj}^{DA}) \right), 0 \right]$$

Real-Time Bid Production Cost Guarantee for Supplier g , which is an Energy Storage Resource or an Aggregation that contains Energy Storage Resource(s) =

$$\text{Max} \left(0, \sum_{i \in M} (InjBPCG_{gi} + WthBPCG_{gi}) \right)$$

where, when an Energy Storage Resource or an Aggregation that contains Energy Storage Resource(s) has a real-time schedule to inject Energy:

$$\begin{aligned} InjBPCG_{gi} = & \left(\left(\int_{\max(EI_{gi}^{DA}, 0)}^{EI_{gi}^{RT}} C_{gi}^{RT} - LBMP_{gi}^{RT} * (EI_{gi}^{RT} - \max(EI_{gi}^{DA}, 0)) \right) * \frac{S_i}{3600} \right) - (NASR_{gi}^{TOT} - NASR_{gi}^{DA}) \\ & - RRAP_{gi} + RRAC_{gi} \end{aligned}$$

and, when an Energy Storage Resource or an Aggregation that contains Energy Storage Resource(s) has a real-time schedule to withdraw Energy =

$$\begin{aligned}
 WthBPCG_{gi} = & \left(\left(\int_{\min(EI_{gi}^{DA}, 0)}^{EI_{gi}^{RT}} C_{gi}^{RT} - LBMP_{gi}^{RT} * (EI_{gi}^{RT} - \min(EI_{gi}^{DA}, 0)) \right) * \frac{S_i}{3600} \right) - (NASR_{gi}^{TOT} - NASR_{gi}^{DA}) \\
 & - RRAP_{gi} + RRAC_{gi}
 \end{aligned}$$

Where:

- $Supplier_g$: Generator g or Aggregation g ;
- S_i : Length of RTD interval i , expressed in seconds
- C_{gi}^{RT} : Bid cost submitted by Supplier g , or when applicable the mitigated Bid cost for Supplier g , in the RTD for the hour that includes RTD interval i expressed in terms of \$/MWh, except in intervals in which the dispatch of the Supplier is constrained by its downward ramp rate for that interval, unless that Supplier was scheduled to provide Regulation Service in that interval and its RTD basepoint was less than its AGC basepoint, and except in hours in which the NYISO has increased Supplier g 's minimum operating level, either (i) at the Supplier's request including through an adjustment to the Resource's self-commitment schedule, or (ii) in order to reconcile the NYISO's dispatch with the Supplier's actual output or to address reliability concerns that arise because the Supplier is not following Base Point Signals, in which case it will be equal to zero;
- MGI_{gi}^{RT} : metered Energy provided by minimum generation segment of Supplier g in RTD interval i expressed in terms of MW;
- MGI_{gi}^{DA} : Energy scheduled Day-Ahead to be produced by minimum generation segment of Supplier g in hour h containing RTD interval i expressed in terms of MW;
- MGC_{gi}^{RT} : Minimum Generation Bid by Supplier g , or when applicable the mitigated Minimum Generation Bid for Supplier g , in the Real-Time Market for the hour that includes RTD interval i , expressed in terms of \$/MWh, which Bid or mitigated Bid may include costs pursuant to Section 4.1.8 of the NYISO Services Tariff;
- If Supplier g was committed in the Day-Ahead Market, or in the Real-Time Market via Supplemental Resource Evaluation ("SRE"), on the day prior to the Dispatch Day *and* Supplier g has not yet completed the minimum run time reflected in the accepted Bid for the hour in which it was scheduled to start on the day before the Dispatch Day (as mitigated, where appropriate), *then* Supplier g will have its minimum generation cost set equal to the revenues received for energy produced at its minimum operating level for purposes of calculating a Real-Time Bid Production Cost Guarantee until Supplier g completes the minimum run time reflected in the accepted Bid for the hour in which it was scheduled to start on the day before the Dispatch Day;
- SUC_{gj}^{RT} : Start-Up Bid by Supplier g , or when applicable the mitigated Start-Up Bid for Supplier g , for hour j into RTD expressed in terms of \$/start, which Bid or mitigated Bid may

include costs pursuant to Section 4.1.8 of the NYISO Services Tariff; *provided, however,*

(i) the Start-Up Bid will be deemed to be zero for (1) Self-Committed Fixed and Self-Committed Flexible Suppliers, (2) Suppliers that are economically committed by RTC or RTD that have 10-minute start-up times that are not synchronized and producing Energy within 20 minutes after their scheduled start time, and (3) Suppliers that are economically committed by RTC that have greater than 10-minute start-up times that are not synchronized and producing Energy within 45 minutes after their scheduled start time;

(ii) if a Supplier has been committed via SRE and its SRE schedule immediately precedes or follows a real-time commitment that did not result from a Day-Ahead commitment, the Supplier's Start-Up Bid included in its daily Real-Time Bid Production Cost Guarantee calculation for this contiguous real-time commitment period will be the Start-Up Bid submitted in response to the SRE request (subject to mitigation, where appropriate);

(iii) if a Supplier has been committed via SRE and its SRE schedule immediately precedes or follows a real-time schedule that resulted from a Day-Ahead commitment, then the Supplier's Start-Up Bid included in its daily real-time Bid Production Cost Guarantee calculation for this contiguous real-time commitment period will be set to zero;

(iv) the real-time Start-Up Bid for Supplier g for the hour j or, when applicable, the mitigated real-time Start-Up Bid, for Supplier g for the hour containing interval i , may be subject to *pro rata* reduction in accordance with the rules illustrated formulaically in this Appendix E. Bases for *pro rata* reduction include, but are not limited to, failure to be scheduled and operate in real-time to produce, in each hour, the MWh specified in the accepted Minimum Generation Bid that was submitted for the first hour of Supplier g 's Day-Ahead or SRE schedule, and failure to operate for the minimum run time specified in the Bid submitted for the first hour of Supplier g 's Day-Ahead or SRE schedule; and

(v) if Supplier g was committed in the Day-Ahead Market, or in the Real-Time Market via SRE, on the day prior to the Dispatch Day, *and Supplier g has not yet completed the minimum run time reflected in the accepted Bid for the hour in which it was scheduled to start on the day before the Dispatch Day (as mitigated, where appropriate) plus the contiguous hour that follows the conclusion of such minimum run time, then Supplier g will have its Start-Up Bid set to zero for purposes of calculating a Real-Time Bid Production Cost Guarantee;*

$NSUI_{gj}^{RT}$: number of times Supplier g started up in the hour j ;

$NSUI_{gj}^{DA}$: number of times Supplier g is scheduled Day-Ahead to start up in hour j ;

$LBMP_{gi}^{RT}$: Real-Time LBMP at Supplier g 's bus in RTD interval i expressed in terms of \$/MWh;

M : the set of eligible RTD intervals in the Dispatch Day consisting of all of the RTD intervals in the Dispatch Day except:

(i) Supplemental Event Intervals (which are addressed separately in section E.5 below);

(ii) intervals during authorized Start-Up Periods, Shutdown Periods, or Testing Periods for Supplier g ;

- L : the set of all hours in the Dispatch Day,
- EI_{gi}^{RT} : either, as the case may be:
 (i) if $EOP_{ig} > AE_{ig}$ then $\min[\max(AE_{ig}, RTSen_{ig}), EOP_{ig}]$; or
 (ii) if otherwise, then $\max[\min(AE_{ig}, RTSen_{ig}), EOP_{ig}]$;
- EI_{gi}^{DA} : Energy scheduled in the Day-Ahead Market to be provided or withdrawn by Supplier g in hour h that includes RTD interval i expressed in terms of MW;
- $RTSen_{ig}$: Real-Time Energy scheduled for Supplier g in interval i , and calculated as the arithmetic average of the 6-second AGC Base Point Signals sent to Supplier g during the course of interval i expressed in terms of MW;
- AE_{ig} : either, (1) when scheduled to withdraw, average Energy Injections plus average Demand Reductions minus average Energy withdrawals by Supplier g in interval i expressed in terms of MW; or (2) otherwise, average Energy injections plus average Demand Reductions minus average Energy withdrawals by Supplier g in interval i but not more than $RTSen_{ig}$ plus any Compensable Overgeneration expressed in terms of MW;;
- EOP_{ig} : the Economic Operating Point of Supplier g in interval i expressed in terms of MW;
- $NASR_{gi}^{TOT}$: Net Ancillary Services revenue, expressed in terms of \$, paid to Supplier g as a result of either having been committed Day-Ahead to operate in the hour that includes RTD interval i or having operated in interval i which is computed by summing the following: (1) Voltage Support Service payments received by that Supplier for that RTD interval, if it is not a Supplier of Installed Capacity; (2) Regulation Service payments that would be made to that Supplier for that hour based on a Performance Index of 1, less the Regulation Capacity and Regulation Movement Bids placed by that Supplier to provide Regulation Service in that hour at the time it was committed to produce Energy for the LBMP Market and/or Ancillary Services to do so; (3) payments made to that Supplier for providing Spinning Reserve or synchronized 30-Minute Reserve in that hour, less the Bid placed by that Supplier to provide such reserves in that hour at the time it was scheduled to do so; and (4) Lost Opportunity Cost payments made to that Supplier in that hour as a result of reducing that Supplier's output in order for it to provide Voltage Support Service.
- $NASR_{gi}^{DA}$: The proportion of the Day-Ahead net Ancillary Services revenue, expressed in terms of \$, that is applicable to interval i calculated by multiplying the $NASR_{gh}^{DA}$ for the hour that includes interval i by $s_i/3600$.
- $RRAP_{gi}$: Regulation Revenue Adjustment Payment for Supplier g in RTD interval i expressed in terms of \$;
- $RRAC_{gi}$: Regulation Revenue Adjustment Charge for Supplier g in RTD interval i expressed in terms of \$.

Note: See also the Calculation of Prorated Start-Up Costs in section E.3 of this Appendix.

E.5. Formula for Determining Real-Time BPCG for Generators and Aggregations in Supplemental Event Intervals

Real-Time Bid Production Cost Guarantee Payment for Generator or Aggregation g, which is not an Energy Storage Resource or an Aggregation that contains an Energy Storage Resource(s) =

$$\sum_{i \in P} \left(\max \left(\left(\int_{\max(EI_{gi}^{DA}, MGI_{gi}^{RT})}^{\max(EI_{gi}^{RT}, MGI_{gi}^{RT})} C_{gi}^{RT} + MGC_{gi}^{RT} * (MGI_{gi}^{RT} - MGI_{gi}^{DA}) \right) * \frac{S_i}{3600} \right), 0 \right) - LBMP_{gi}^{RT} * (EI_{gi}^{RT} - EI_{gi}^{DA}) - (NASR_{gi}^{TOT} - NASR_{gi}^{DA}) - RRAP_{gi} + RRAC_{gi}$$

Real-Time Bid Production Cost Guarantee for Supplier g, which is an Energy Storage Resource or an Aggregation that contains an Energy Storage Resource(s) =

$$\text{Max} \left(0, \sum_{i \in P} (InjBPCG_{gi} + WthBPCG_{gi}) \right)$$

where, when an Energy Storage Resource or an Aggregation that contains an Energy Storage Resource(s) has a real-time schedule to inject Energy:

$$InjBPCG_{gi} = \left(\left(\int_{\max(EI_{gi}^{DA}, 0)}^{EI_{gi}^{RT}} C_{gi}^{RT} - LBMP_{gi}^{RT} * (EI_{gi}^{RT} - \max(EI_{gi}^{DA}, 0)) \right) * \frac{S_i}{3600} \right) - (NASR_{gi}^{TOT} - NASR_{gi}^{DA}) - RRAP_{gi} + RRAC_{gi}$$

and, when an Energy Storage Resource or an Aggregation that contains an Energy Storage Resource(s) has a real-time schedule to withdraw Energy =

$$WthBPCG_{gi} = \left(\left(\int_{\min(EI_{gi}^{DA}, 0)}^{EI_{gi}^{RT}} C_{gi}^{RT} - LBMP_{gi}^{RT} * (EI_{gi}^{RT} - \min(EI_{gi}^{DA}, 0)) \right) * \frac{S_i}{3600} \right) - (NASR_{gi}^{TOT} - NASR_{gi}^{DA}) - RRAP_{gi} + RRAC_{gi}$$

where:

Supplier_g: Generator g or Aggregation g

P: the set of Supplemental Event Intervals in the Dispatch Day but excluding any intervals in which there are maximum generation pickups or large event reserve pickups where EI_{gi}^{RT} less than or equal to EI_{gi}^{DA} ; and

EI_{gi}^{RT} : (i) for any intervals in which there are maximum generation pickups, and the three intervals following, for Suppliers in the location for which the maximum generation pickup has been called -- the average Actual Energy Injections, expressed in MWh, for Generator g in interval i, and for all other Suppliers as defined in section E.4 above.
(ii) for any intervals in which there are large event reserve pickups and the three intervals following, as defined in section E.4 above.

C_{gi}^{RT} : Bid cost submitted by Supplier g, or when applicable the mitigated Bid cost for Supplier g, in the RTD for the hour that includes RTD interval i expressed in terms of \$/MWh, except in hours in which the NYISO has increased Supplier g's minimum operating level, either (i) at the Supplier's request, or (ii) in order to reconcile the NYISO's dispatch with the Supplier's actual output or to address reliability concerns that arise because the Supplier is not following Base Point Signals, in which case it will be deemed to be zero;

The definition of all other variables is identical to those defined in section E.4 above.

Bids Used For Intervals at the End of the Hour

For RTD intervals in an hour that start 55 minutes or later after the start of that hour, a Bid used to determine Real-Time BPCG above will be the Bid for the next hour in accordance with NYISO Procedures. For RTD-CAM intervals in an hour that start 50 minutes or later after the start of that hour, a Bid used to determine Real-Time BPCG above will be the Bid for the next hour, in accordance with NYISO Procedures.

E.6. Day-Ahead BPCG for Imports

$$\max \left[\sum_{h=1}^N (DecBid_{th}^{DA} - LBMP_{th}^{DA}) * SchImport_{th}^{DA}, 0 \right]$$

Where:

- N : Number of hours in the Day-Ahead Market day;
- $DecBid_{th}^{DA}$: Decremental Bid, in \$/MWh, supplied for Import t for hour h ;
- $LBMP_{th}^{DA}$: Day-Ahead LBMP, in \$/MWh, for hour h at the Proxy Generator Bus that is the source of the Import t ; and
- $SchImport_{th}^{DA}$: Total Day-Ahead schedule, in MWh, for Import t in hour h .

E.7. Day-Ahead BPCG for Demand Reduction

$$\max \left\{ \left[\sum_{h=1}^N (MinCurCost_d^h + IncrCurCost_d^h - CurRev_d^h) + CurInitCost_d \right], 0 \right\}$$

Where:

- $CurInitCost_d = \left(\sum_{h=1}^N (Min(ActCur_d^h, SchdCur_d^h)) \div (\sum_{h=1}^N SchdCur_d^h) \right) \times CurCost_d$
- $MinCurCost_d^h = Min \left((max(Actcur_d^h, 0), MinCur_d^h) \right) \times MinCurBid_d^h$;
- $IncrCurCost_d^h = \int_{MinCur_d^h}^{max(MinCur_d^h, min(SchdCur_d^h, ActCur_d^h))} IncrCurBid_d^h$;
- $CurRev_d^h = LBMP_{dh}^{DA} \times min(max(ActCur_d^h, 0), SchdCur_d^h)$;
- N : number of hours in the Day-Ahead Market day;
- $CurInitCost_d$: daily Curtailment Initiation Cost credit for Day-Ahead Demand Reduction Provider d ;
- $MinCurCost_d^h$: minimum Curtailment cost credit for Day-Ahead Demand Reduction Provider d in hour h ;
- $IncrCurCost_d^h$: incremental Curtailment cost credit for Day-Ahead Demand Reduction Provider d for hour h ;
- $CurCost_d$: total Bid Curtailment Initiation Costs for Day-Ahead Demand Reduction Provider d for the day;
- $CurRev_d^h$: actual revenue for Day-Ahead Demand Reduction Provider d in hour h ;
- $ActCur_d^h$: actual Energy curtailed by Day-Ahead Demand Reduction Provider d in hour h expressed in terms of MWh;
- $SchdCur_d^h$: Energy scheduled Day-Ahead to be curtailed by Day-Ahead Demand Reduction Provider d in hour h expressed in terms of MWh;

- $MinCurBid_h^d$: minimum Curtailment initiation Bid submitted by Day-Ahead Demand Reduction Provider d for hour h expressed in terms of \$/MWh;
- $IncrCurBid_h^d$: Bid cost submitted by Day-Ahead Demand Reduction Provider d for hour h expressed in terms of \$/MWh;
- $MinCur_h^d$: Energy scheduled Day-Ahead to be produced by the minimum Curtailment segment of Day-Ahead Demand Reduction Provider d for hour h expressed in terms of MWh; and
- $LBMP_{dh}^{DA}$: Day-Ahead LBMP for Day-Ahead Demand Reduction Provider d for hour h expressed in \$/MWh.

E.8. Day-Ahead BPCG for Demand Side Resources Providing Synchronized Operating Reserves and/or Regulation Service

$$\max \left\{ \left[- \sum_{h=1}^N NASR_{dh}^{DA} \right], 0 \right\}$$

Where:

- N : number of hours in the Day-Ahead Market day;
- $NASR_{dh}^{DA}$: Net Ancillary Services revenue, in \$, paid to Demand Side Resource d as a result of having been committed to provide Ancillary Services Day-Ahead in hour h which is computed as follows:

$$NASR_{dh}^{DA} = (REGCS_{dh}^{DA} - REGCB_{dh}^{DA}) + (OPResS_{dh}^{DA} - OPResB_{dh}^{DA})$$

Where:

- $REGCS_{dh}^{DA}$: Regulation Capacity payments made to that Demand Side Resource d for all Regulation Capacity it is scheduled Day-Ahead for hour h ;
- $REGCB_{dh}^{DA}$: Demand Side Resource d 's Day-Ahead Regulation Capacity Bid to provide that amount of Regulation Service in hour h ;
- $OPResS_{dh}^{DA}$: Payments made to Demand Side Resource d for providing Spinning Reserve and synchronized 30-Minute Reserve in hour h for Day-Ahead commitments to provide such reserves;
- $OPResB_{dh}^{DA}$: Demand Side Resource d 's Day-Ahead Bid to provide Spinning Reserve and synchronized 30-Minute Reserve in hour h .

E.9. Real-Time BPCG for Demand Side Resources Providing Synchronized Operating Reserves and/or Regulation Service

$$\max \left[- \sum_{i=1}^L NASR_{di}^{RT}, 0 \right]$$

Where:

- L : set of RTD intervals in the Dispatch Day;
- $NASR_{di}^{RT}$: Net Ancillary Services revenue, in \$, paid to Demand Side Resource d as a result of operating in RTD interval i in a manner different than that of Demand Side Resource d 's Day-Ahead Commitment for the hour containing RTD interval i which is computed as follows:

$$NASR_{di}^{RT} = (REGCS_{di}^{RT} - REGCB_{di}^{RT}) + (REGMS_{di}^{RT} - REGMB_{di}^{RT}) + (OPResS_{di}^{RT} - OPResB_{di}^{RT})$$

Where:

- $REGCS_{di}^{RT}$: Regulation Capacity payments that would be made to Demand Side Resource d for additional Regulation Capacity scheduled in real time for RTD interval i ;
- $REGCB_{di}^{RT}$: Demand Side Resource d 's Real-Time Market Regulation Capacity Bid to provide that amount of Regulation Capacity in the hour containing interval i ;
- $REGMS_{di}^{RT}$: Regulation Movement payments that would be made to Demand Side Resource d for all Regulation Movement scheduled for RTD interval based on a Performance Index of 1,
- $REGMB_{di}^{RT}$: Demand Side Resource d 's Real-Time Market Regulation Movement Bid to provide that amount of Regulation Movement in the hour containing interval i ;
- $OPResS_{di}^{RT}$: Payments made to Demand Side Resource d for providing Spinning Reserve or synchronized 30-Minute Reserve, net of the Spinning Reserve or synchronized 30-Minute Reserve scheduled in the Day-Ahead Market in the hour containing interval i ;
- $OPResB_{di}^{RT}$: The Bid placed by Demand Side Resource d to provide such reserves in the hour containing interval i at the time it was scheduled to do so;

E.10. Import Curtailment Guarantee Payment for a Supplier Whose Import Was Curtailed by the NYISO

$$\sum_{h=1}^N \max \left\{ \left[\sum_{i=1}^H \left((RTLBM P_{ti} \times \{DAen_{ti} - RTDen_{ti}\}) - \max \left(\int_{RTDen_{ti}}^{DAen_{thi}} DABid_{thi}, 0 \right) \times \{s_i^{RT} \div 3600 \text{ seconds}\} \right) \right], 0 \right\}$$

Where:

- N : the number of hours in the Dispatch Day;
- H : the number of intervals in hour h ;
- s_i^{RT} : Length of RTD interval i , expressed in seconds;
- $RTLBM P_{ti}$: the Real-Time LBMP, in \$/MWh, for interval i at the Proxy Generator Bus which is the source of the Import t ;

- $DABid_{thi}$: the Day Ahead Bid prices associated with the Day-Ahead energy schedule, in \$/MWh, for Import t in hour h containing interval i ;
- $DAen_{thi}$: the Day Ahead scheduled Energy injections, in MWh, for Import t in hour h containing interval i as determined by Security Constrained Unit Commitment (SCUC); and
- $RTDen_{ti}$: the scheduled Energy injections, in MWh, for Import t in interval i as determined by Real-Time Dispatch (RTD).

Appendix F. Economic Operating Point

A Generator's Economic Operating Point (EOP) is a point on its Incremental Energy Bid curve that is a function of the Real-Time LBMP at the Generator's bus, the Generator's Real-Time Energy injection, Real-Time Scheduled Energy Injection, stated response rate and EOP in the previous RTD interval, which may be the Generator's Real-Time Scheduled Energy Injection. A Supplier's Economic Operating Point may be above, below, or equal to its Real-Time Scheduled Energy Injection.

If the RTD interval LBMP, depicted as *RTD RT Total Price (\$/MWh)* in the diagram below, is less than the cost component of the first point on a Generator's Bid curve, depicted as P_1 in the diagram below, then the Generator's EOP is equal to the megawatt component of the first point on the Generator's cost curve (i.e., Q_1). Note, for an Energy Storage Resource the EOP will be set to the Lower Operating Limit.

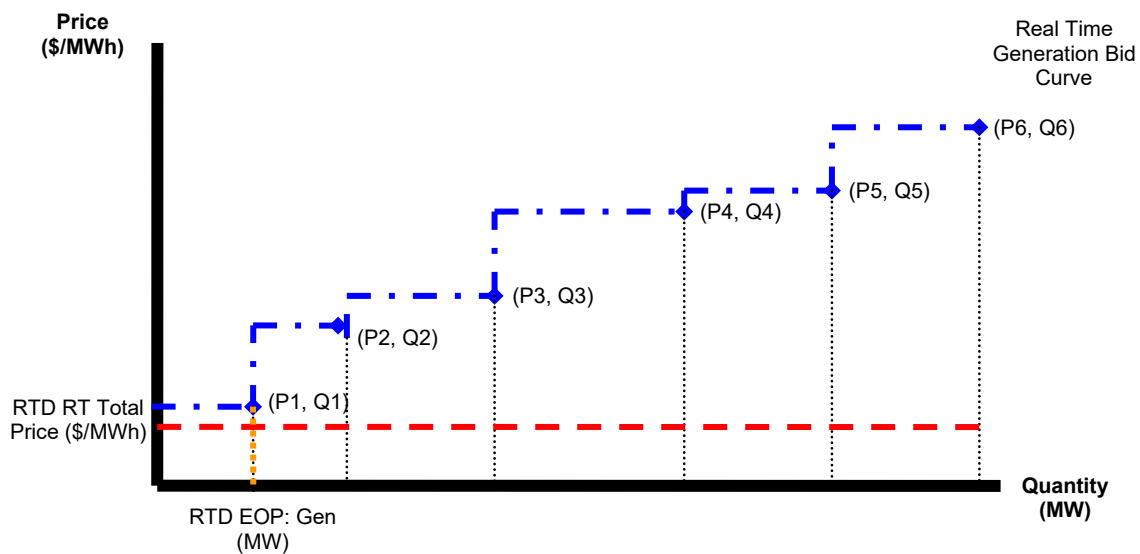

If the RTD interval LBMP (i.e., *RTD RT Total Price (\$/MWh)*) is greater than the cost component of the last point on a Generator's Bid curve, depicted as P_6 in the diagram below, then the Generator's EOP is equal to the megawatt component of the last point on its cost curve (i.e., Q_6).

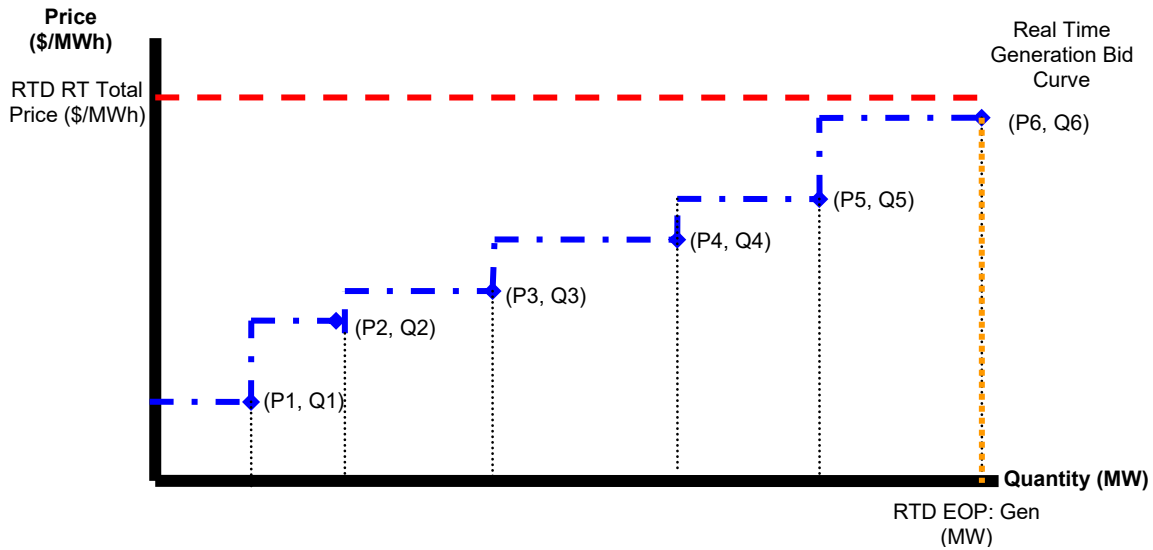

If the RTD interval LBMP is greater than or equal to the cost component of the first point on a Generator’s Bid curve (i.e., P_1) and less or equal to the cost component of the last point on the unit’s cost curve (i.e. P_6), then in order to determine a Generator’s EOP the Generation Bid block that the RTD interval LBMP intersects first must be identified by determining the lowest-priced block point where RTD Gen Bid: Price_n (\$/MWh) \geq RTD RT Total Price (\$/MWh). For example, in the diagram below the RTD interval LBMP intersects the given Generation Bid block on a vertical line; therefore, the EOP is equal to the lower Generation Bid block megawatt value of the given block (i.e., Q_3).

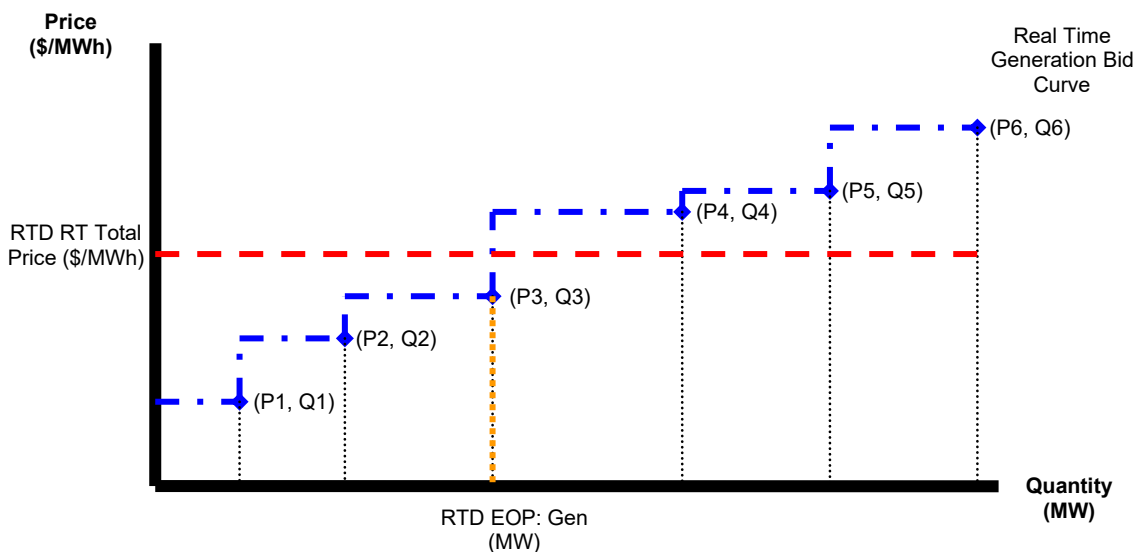

If the RTD interval LBMP intersects the given Generation Bid block on a horizontal line and the Generator’s RTD Base Point is greater than the megawatt component of the last point on the Generator’s Bid curve, as in the diagram below, then the Generator’s EOP is equal the its RTD Base Point.

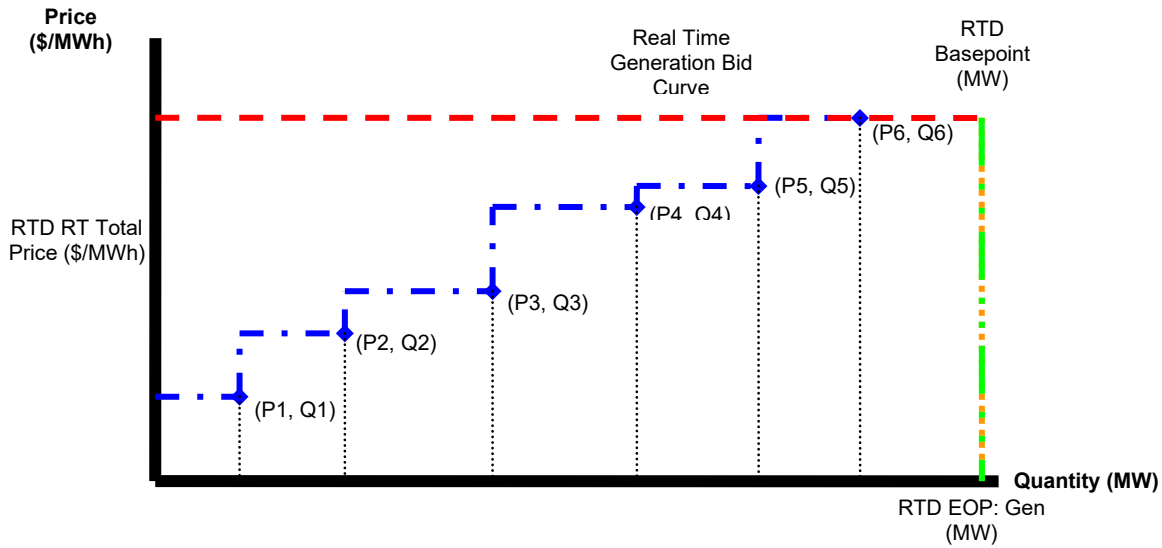

Similarly, if the RTD interval LBMP intersects the given Generation Bid block on a horizontal line and the Generator was Base Pointed within the same Bid block, the Generator’s EOP is equal to its RTD Base Point.

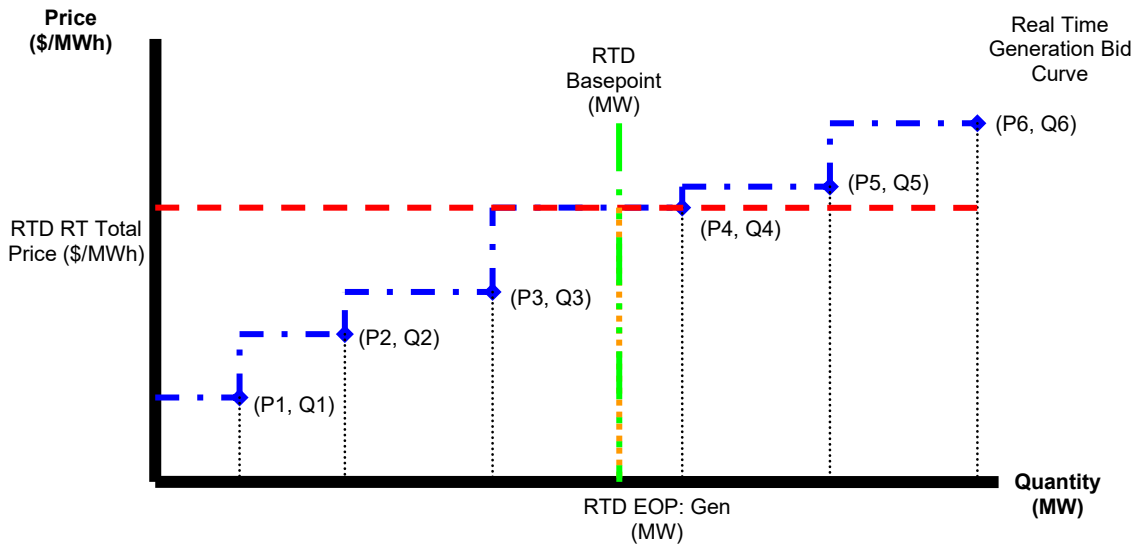

In the diagram below, however, the RTD interval LBMP intersects the given Generation Bid block on a horizontal line; however, the Generator was Base Pointed beyond its economics. In this case, the Generator’s EOP is equal to the higher Generation Block MW (i.e., Q_4) of the block where the RTD interval LBMP intersects the Generation Bid.

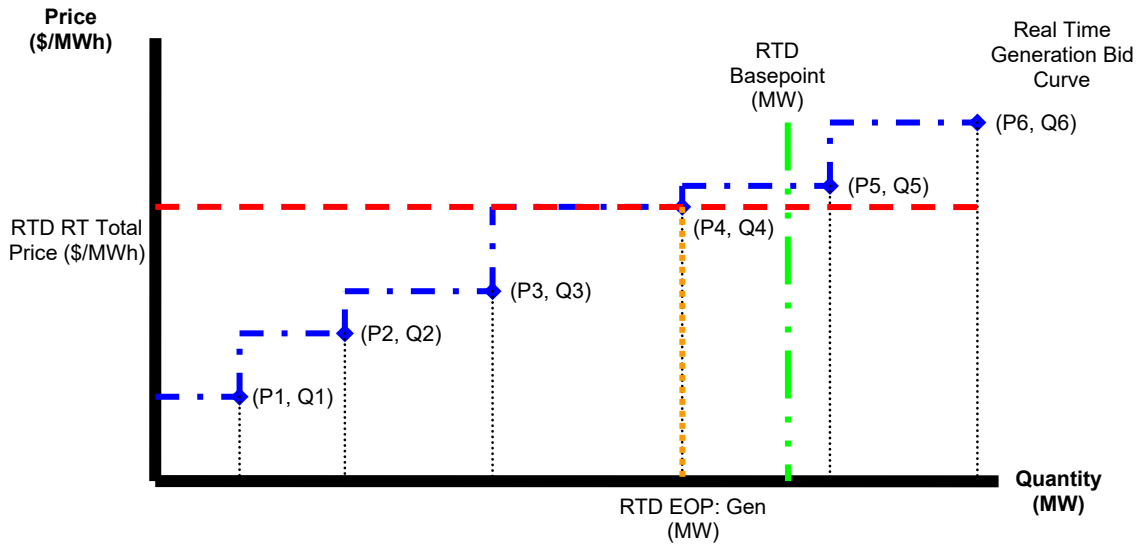

In the diagram below, the RTD interval LBMP intersects the given Generation Bid block on a horizontal line and the Generator was Base Pointed below the given Generation Bid block. In this case, the Generator's EOP is equal to the lower Generation Block MW (i.e., Q_3) of the block where the RTD interval LBMP intersects the Generation Bid.

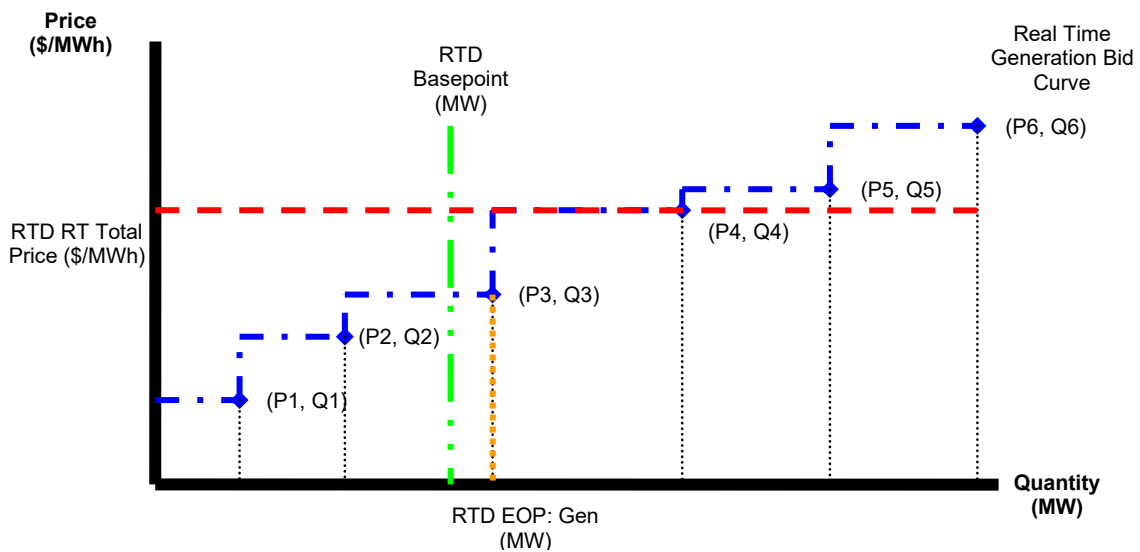

Appendix G. Real-Time Performance Tracking

The NYISO's Performance Tracking System (PTS) produces RTD-interval calculations for use by the Billing and Settlement System (BSS) and Market Information System (MIS). The calculations produced by the PTS are unit average output over an RTD interval, average tie flow over an RTD interval, unit average desired generation over an RTD interval, unit average ramped RTD base point over an RTD interval, unit positive control error for regulating units, unit negative control error for regulating units, unit regulation performance index, unit Reserve Performance Index, and total regulation movement.

G.1. Average Injection over an RTD Interval

$$\sum_{s=1}^n EI_{gs}^{RT} \div n$$

Where:

- n : Number of Real-Time EMS data scans s over RTD interval i
- EI_{gs}^{RT} : Energy injected by Generator g during EMS data scan s , expressed in terms of MW;

G.2. Average Withdrawal over an RTD Interval

$$\sum_{s=1}^n EW_{gs}^{RT} \div n$$

Where:

- n : Number of Real-Time EMS data scans s over RTD interval i
- EW_{gs}^{RT} : Energy withdrawal by Generator g during EMS data scan s , expressed in terms of MW;

G.3. Average Demand Reduction over an RTD Interval

$$\sum_{s=1}^n DR_{gs}^{RT} \div n$$

Where:

- n : Number of Real-Time EMS data scans s over RTD interval i
- DR_{gs}^{RT} : Demand Reduction by DER Aggregation g during EMS data scan s , expressed in terms of MW;

G.4. Average Tie Flow over an RTD Interval

$$\sum_{s=1}^n EF_{gs}^{RT} \div n$$

Where:

- n : Number of Real-Time EMS data scans s over RTD interval i
- EF_{ts}^{RT} : Tie-line flow across Tie-line t during EMS data scan s , expressed in terms of MW;

G.5. Average Ramped RTD Base-point per RTD Interval

$$\sum_{s=1}^n RTD_{gs}^{RT} \div n$$

Where:

- n : Number of Real-Time EMS data scans s over RTD interval i
- RTD_{gs}^{RT} : RTD ramped base point issued to Generator g during EMS data scan s , expressed in terms of MW;

For an LESR, Average Ramped RTD Base-point will always be 0.

G.6. Unit Average Desired Generation per RTD Interval

G.6.1. For Suppliers providing Regulation Service

$$\sum_{s=1}^n AGC_{gs}^{RT} \div n$$

G.6.2. For Suppliers not providing Regulation Service:

$$RTD_{gi}^{RT}$$

Where:

- n : Number of Real-Time EMS data scans s over RTD interval i
- AGC_{gs}^{RT} : AGC base point issued to Generator g during EMS data scan s , expressed in terms of MW;
- RTD_{gs}^{RT} : RTD ramped base point issued to Generator g over RTD interval i , expressed in terms of megawatts [as computed above];

For an LESR, Average Desired MW will always be 0.

G.7. Negative Control Error for Suppliers providing Regulation Service

$$\left\{ \sum_{s=1}^n \text{Max}[(AGC_{gsmin}^{RT} - EI_{gs}^{RT}), 0] \right\} \div n$$

Where:

- n : Number of 30-second blocks within RTD interval i
- AGC_{gsmin}^{RT} : Minimum Desired (AGC) base point for Generator g over the 30-second block of 6-second EMS data scan s , expressed in terms of MW;
- EI_{gs}^{RT} : Energy injected by Generator g during EMS data scan s , expressed in terms of MW;

G.8. Positive Control Error for Suppliers that are providing Regulation Service

$$\left\{ \sum_{s=1}^n \text{Max}[(EI_{gs}^{RT} - AGC_{gsmax}^{RT}), 0] \right\} \div n$$

Where:

- n : Number of 30-second blocks within RTD interval i
- AGC_{gsmax}^{RT} : Maximum Desired (AGC) base point for Generator g over the 30-second block of 6-second EMS data scan s , expressed in terms of MW;
- EI_{gs}^{RT} : Energy injected by Generator g during EMS data scan s , expressed in terms of MW;

G.9. Regulation Performance Index

$$\text{Min} \left\{ \text{Max} \left[\left(\frac{\text{Reg}_{gi}^{RT} - (\text{PCE}_{gi}^{RT} + \text{NCE}_{gi}^{RT})}{\text{Reg}_{gi}^{RT}} + 0.10 \right), 0 \right], 1 \right\} \times \{ \text{RGPD} \div s_i^{RT} \}$$

Where:

- s_i^{RT} : Length of RTD interval i , expressed in seconds;
- Reg_{gi}^{RT} : Regulation Capacity Schedule for Generator g during RTD interval i , expressed in terms of MW;
- RGPD : Amount of time that Generator g provided Regulation Service during RTD interval i , expressed in terms of seconds
- PCE_{gi}^{RT} : Positive Control Error for Generator g over RTD interval i , as computed above;
- NCE_{gi}^{RT} : Negative Control Error for Generator g over RTD interval i , as computed above;

Note: This does not apply to intervals initiated as a result of a Reserve, Large Event, or Maximum Generation Pick-up and the 3 intervals that follow. In these cases the Performance Index is 1.

G.10. Reserve Performance Index

$$\text{Min} \left\{ \left[\frac{\{\sum_{i=1}^n \text{Max}(ADR_{di}^{RT}, 0)\} \div n}{\{\sum_{i=1}^n \text{Max}(SDR_{di}^{RT}, 0)\} \div n} + 0.10 \right], 1 \right\}$$

Where:

- n : Number of Real-Time EMS data scans s over RTD interval i
- SDR_{di}^{RT} : Average scheduled demand reduction for Demand Side Resource d , over interval i , expressed as MW;
- ADR_{di}^{RT} : Average actual demand reduction by Demand Side Resource d , over interval i , expressed as MW;

G.11. Total Regulation Movement

$$\sum_{i=1}^n \text{RTMreg}_{gs}$$

Where:

- n : Number of Real-Time EMS data scans s over RTD interval i ;
- RTMreg_{gs} : Total MW movement that Generator g was instructed to provide during EMS data scan s expressed in terms of MW

Appendix H. DAM Margin Assurance Payments (DAMAP)

Day-Ahead Margin Assurance Payments (DAMAP) to Generators and Demand Side Resources are determined through the equations illustrated formulaically in this appendix and described in Section 4.1.5 of this manual.

H.1. Hourly DAMAP for Generators

$$\max \left\{ 0, \sum_{i=1}^n \left[CDAMPEn_{iu} + \sum_p (CDAMPRes_{iup}) + CDAMPReg_{iu} \right] \right\}$$

Where:

- n : Number of intervals i in hour h
- $CDAMPEn_{iu}$: Energy component of the DAMAP to Supplier u for interval i , expressed in \$;
- $CDAMPRes_{iup}$: Operating Reserves Service component of the DAMAP to Supplier u for interval i , determined separately for each Operating Reserves Service product p , expressed in \$;
- $CDAMPReg_{iu}$: Regulation Service component of the DAMAP to Supplier u for interval i , expressed in \$;

H.2. RTD Interval Energy Component of DAMAP When Eligible Generators' Real-Time Energy Schedules are Less Than Their DAM Energy Schedules

If the Generator's (i) Day-Ahead Energy schedule is to inject Energy (i.e., greater than zero MW) and its real-time Energy schedule is lower than its Day-Ahead Energy schedule; or (ii) Day-Ahead Energy schedule is to withdraw Energy (i.e., less than zero MW) and its real-time Energy schedule is greater than its Day-Ahead Energy schedule, then:

$$CDMAPen_{iu} = \left((DASen_{hu} - LL_{iu}) * RTPen_{iu} - \int_{LL_{iu}}^{DASen_{hu}} DABen_{hu} \right) * \frac{Seconds_i}{3600}$$

Where:

- $CDMAPen_{iu}$ = the Energy contribution of RTD interval i to the Day-Ahead Margin Assurance Payment for Supplier u ;
- $DASen_{hu}$ = Day-Ahead Energy schedule for Supplier u in hour h ;
- $DABen_{hu}$ = Day-Ahead Energy Bid cost for Supplier u in hour h , including the Minimum Generation Bid and Incremental Energy Bids;

$RTSen_{iu}$ = real-time Energy scheduled for Supplier u in interval i , and calculated as the arithmetic average of the 6-second AGC Base Point Signals sent to Supplier u during the course of interval i ;

$RTBen_{iu}$ = real-time Energy Bid cost for Supplier u in interval i , including the Minimum Generation Bid and Incremental Energy Bids.

AE_{iu} = either, (1) when $RTSen_{iu}$ is greater than zero MW, average Energy injections plus average Demand Reductions minus average Energy withdrawals by Supplier u in interval i but not more than $RTSen_{iu}$ plus Compensable Overgeneration; or (2) when $RTSen_{iu}$ is less than or equal to zero MW, average Energy injections plus average Demand Reductions minus average Energy withdrawals by Supplier u in interval i ;

$RTPen_{iu}$ = real-time price of Energy at the location of Supplier u in interval i ;

LL_{iu} = When the Day-Ahead Energy schedule is to inject, given that $RTSen_{iu} < DASen_{hu}$, either:

(a) if $RTSen_{iu} < EOP_{iu}$, then $LL_{iu} = \max(\min(\max(RTSen_{iu}, \min(AE_{iu}, EOP_{iu})), DASen_{hu}), 0)$; or

(b) if $RTSen_{iu} \geq EOP_{iu}$, then $LL_{iu} = \max(\min(RTSen_{iu}, \max(AE_{iu}, EOP_{iu})), DASen_{hu}), 0)$

When the Day-Ahead Energy schedule is to withdraw, given that $RTSen_{iu} > DASen_{hu}$:

$LL_{iu} = \min(\max(DASen_{hu}, AE_{iu}, EOP_{iu}), RTSen_{iu}, 0)$

UL_{iu} = When the Day-Ahead Energy schedule is to inject, or Day-Ahead Energy schedule is zero MW and real-time Energy schedule is to inject, given that $RTSen_{iu} \geq DASen_{hu}$, either:

(a) if $RTSen_{iu} \geq EOP_{iu} \geq DASen_{hu}$, then $UL_{iu} = \max(\min(RTSen_{iu}, \max(AE_{iu}, EOP_{iu})), DASen_{hu})$; or

(b) otherwise, then $UL_{iu} = \max(RTSen_{iu}, \min(AE_{iu}, EOP_{iu}), DASen_{hu})$

When the Day-Ahead Energy schedule is to withdraw, or Day-Ahead Energy schedule is zero MW and real-time Energy schedule is to withdraw, given that $RTSen_{iu} \leq DASen_{hu}$:

$UL_{iu} = \min(\max(AE_{iu}, EOP_{iu}), RTSen_{iu}, DASen_{iu})$

EOP_{iu} = the Economic Operating Point of Supplier u in interval i calculated without regard to ramp rates;

$Seconds_i$ = number of seconds in interval i

H.3. RTD Interval Energy Component of DAMAP When Eligible Generators' Real-Time Energy Schedules are Greater Than or Equal to Their DAM Energy Schedules

If the Generator's (i) Day-Ahead Energy schedule is to inject Energy (i.e., greater than zero MW) and its real-time Energy schedule is greater than or equal to its Day-Ahead Energy schedule; or (ii) Day-Ahead Energy schedule is to withdraw Energy (i.e., less than zero MW), and real-time Energy schedule less than or equal to its Day-Ahead Energy schedule; or (iii) Day-Ahead Energy schedule is for zero MW, then:

$$CDMAPen_{iu} = \min \left[\left(DASen_{hu} - UL_{iu} \right) * RTPen_{iu} + \int_{DASen_{hu}}^{UL_{iu}} RTBen_{iu} \right) * \frac{Seconds_i}{3600}, 0 \right]$$

Where:

- $CDMAPen_{iu}$ = the Energy contribution of RTD interval i to the Day-Ahead Margin Assurance Payment for Supplier u ;
 - $DASen_{hu}$ = Day-Ahead Energy schedule for Supplier u in hour h ;
 - $DABen_{hu}$ = Day-Ahead Energy Bid cost for Supplier u in hour h , including the Minimum Generation Bid and Incremental Energy Bids;
 - $RTSen_{iu}$ = real-time Energy scheduled for Supplier u in interval i , and calculated as the arithmetic average of the 6-second AGC Base Point Signals sent to Supplier u during the course of interval i ;
 - $RTBen_{iu}$ = real-time Energy Bid cost for Supplier u in interval i , including the Minimum Generation Bid and Incremental Energy Bids.
 - AE_{iu} = either, (1) when $RTSen_{iu}$ is greater than zero MW, average Energy injections plus average Demand Reductions minus average Energy withdrawals by Supplier u in interval i but not more than $RTSen_{iu}$ plus Compensable Overgeneration; or (2) when $RTSen_{iu}$ is less than or equal to zero MW, average Energy injections plus average Demand Reductions minus average Energy withdrawals by Supplier u in interval i
 - $RTPen_{iu}$ = real-time price of Energy at the location of Supplier u in interval i ;
 - LL_{iu} = When the Day-Ahead Energy schedule is to inject, given that $RTSen_{iu} < DASen_{hu}$, either:
 - (a) if $RTSen_{iu} < EOP_{iu}$, then $LL_{iu} = \max(\min(\max(RTSen_{iu}, \min(AE_{iu}, EOP_{iu})), DASen_{hu}), 0)$; or
 - (b) if $RTSen_{iu} \geq EOP_{iu}$, then $LL_{iu} = \max(\min(RTSen_{iu}, \max(AE_{iu}, EOP_{iu})), DASen_{hu}), 0)$
- When the Day-Ahead Energy schedule is to withdraw, given that $RTSen_{iu} > DASen_{hu}$:
- $$LL_{iu} = \min(\max(DASen_{hu}, AE_{iu}, EOP_{iu}), RTSen_{iu}, 0)$$

UL_{iu} = When the Day-Ahead Energy schedule is to inject, or Day-Ahead Energy schedule is zero MW and real-time Energy schedule is to inject, given that $RTSen_{iu} \geq DASen_{hu}$, either:

(c) if $RTSen_{iu} \geq EOP_{iu} \geq DASen_{hu}$, then $UL_{iu} = \max(\min(RTSen_{iu}, \max(AE_{iu}, EOP_{iu})), DASen_{hu})$; or

(d) otherwise, then $UL_{iu} = \max(RTSen_{iu}, \min(AE_{iu}, EOP_{iu}), DASen_{hu})$

When the Day-Ahead Energy schedule is to withdraw, or Day-Ahead Energy schedule is zero MW and real-time Energy schedule is to withdraw, given that $RTSen_{iu} \leq DASen_{hu}$:

$$UL_{iu} = \min(\max(AE_{iu}, EOP_{iu}), RTSen_{iu}, DASen_{iu})$$

EOP_{iu} = the Economic Operating Point of Supplier u in interval i calculated without regard to ramp rates;

$Seconds_i$ = number of seconds in interval i

H.4. RTD Interval Regulation Service Component of DAMAP When Eligible Generators' Real-Time Regulation Schedules are Different than their DAM Regulation Schedules

H.4.1. Real-Time Regulation Service schedule less than Day-Ahead Regulation Service schedule:

$$CDMAPReg_{iu} = \{[(\{SReg_{hu}^{DA} - REDReg_{iu}\} - SReg_{iu}^{RT}) \times (PReg_{iu}^{RT} - BReg_{hu}^{DA})] \times [s_i^{RT} \div 3600 \text{ seconds}]\} + \{[-1 \times RegM_{iu}^{RT}] \times \max[0, PRegM_{iu}^{RT} - BRegM_{iu}^{RT}]\}$$

Where:

s_i^{RT} : Length of RTD interval i , expressed in seconds;

$SReg_{hu}^{DA}$: Day Ahead Regulation Service schedule for Supplier u in hour h containing RTD interval i , expressed in MW;

$REDReg_{iu}$: Adjustment to reflect changes in the Emergency Upper Operating Limit or Normal Upper Operating Limit, whichever is applicable, in the event that Supplier u requests and is granted a derate of its Real-Time Operating Capacity as described in H.10.2 below;

$SReg_{iu}^{RT}$: the Real-Time Regulation Service scheduled for Supplier u in RTD interval i , expressed in MW;

$PReg_{iu}^{RT}$: the Real-Time Regulation Capacity Market Price at the location of Supplier u in RTD interval i , expressed in \$/MW;

$BReg_{hu}^{DA}$: DAM Regulation Capacity Bid price by Supplier u in hour h , expressed in \$/MW;

$RegM_{iu}^{RT}$: the Real-Time Regulation Movement for Supplier u in RTD interval i , expressed in MW;

$BRegM_{iu}^{RT}$: the Real-Time Regulation Movement Bid price by Supplier u in RTD interval i , expressed in \$/MW;

H.4.2. Real-Time Regulation Service schedule greater than or equal to the Day-Ahead Regulation Service schedule:

$$CDMAPReg_{iu} = \{[(SReg_{hu}^{DA} - REDReg_{iu}) - SReg_{iu}^{RT}] \times \max(0, PReg_{iu}^{RT} - BReg_{iu}^{RT})\} \\ \times [s_i^{RT} \div 3600 \text{ seconds}] + \{-1 \times RegM_{iu}^{RT}\} \times \max[0, (PRegM_{iu}^{RT} - BRegM_{iu}^{RT})]$$

Where:

s_i^{RT} : Length of RTD interval i , expressed in seconds;

$SReg_{hu}^{DA}$: Day Ahead Regulation Service schedule for Supplier u in hour h containing RTD interval i , expressed in MW;

$REDReg_{iu}$: Adjustment to reflect changes in the Emergency Upper Operating Limit or Normal Upper Operating Limit, whichever is applicable, in the event that Supplier u requests and is granted a derate of its Real-Time Operating Capacity as described in H.10.2 below;

$SReg_{iu}^{RT}$: the Real-Time Regulation Service scheduled for Supplier u in RTD interval i , expressed in MW;

$PReg_{iu}^{RT}$: the Real-Time Regulation Capacity Market Price at the location of Supplier u in RTD interval i , expressed in \$/MW;

$BReg_{iu}^{RT}$: the Real-Time Regulation Capacity Bid price by Supplier u in RTD interval i , expressed in \$/MW;

$RegM_{iu}^{RT}$: the Real-Time Regulation Movement for Supplier u in RTD interval i , expressed in MW;

$PRegM_{iu}^{RT}$: Real-Time Regulation Movement Market Price at the location of Supplier u in interval i ;

$BRegM_{iu}^{RT}$: the Real-Time Regulation Movement Bid price by Supplier u in RTD interval i , expressed in \$/MW;

H.5. RTD Interval Operating Reserves Component of DAMAP When Eligible Generators' Real-Time Reserves Schedules for any Operating Reserves Products are Different than their DAM Reserves Schedules

H.5.1. Real-Time Operating Reserve less than Day-Ahead Operating Reserve:

$$CDMAPRes_{iup} = \{[(SRes_{hup}^{DA} - REDRes_{iup}) - SRes_{iup}^{RT}] \times [PRes_{iup}^{RT} - BRes_{hup}^{DA}]\} \\ \times [s_i^{RT} \div 3600 \text{ seconds}]$$

Where:

s_i^{RT} : Length of RTD interval i , expressed in seconds;

- $SRes_{hup}^{DA}$: Day Ahead Operating Reserves Service schedule for product p for Supplier u in hour h containing RTD interval i , expressed in MW;
- $REDRes_{iup}$: Adjustment to reflect changes in the Emergency Upper Operating Limit or Normal Upper Operating Limit, whichever is applicable, in the event that Supplier u requests and is granted a derate of its Real-Time Operating Capacity as described in H.10.3 below;
- $SRes_{iup}^{RT}$: the Real-Time Operating Reserve Service scheduled for product p for Supplier u in RTD interval i , expressed in MW;
- $PRes_{iup}^{RT}$: the Real-Time Market Clearing Price for Operating Reserve Service for product p at the location of Supplier u in RTD interval i , expressed in \$/MW;
- $BRes_{hup}^{DA}$: Day Ahead Market Availability Bid for Operating Reserves Service Bid for product p by Supplier u in hour h , expressed in \$/MW;

H.5.2. Real-Time Operating Reserve greater than or equal to Day-Ahead Operating Reserve:

$$CDMAPRes_{iup} = \{[(SRes_{hup}^{DA} - REDRes_{iup}) - SRes_{iup}^{RT}] \times PRes_{iup}^{RT}\} \times \{s_i^{RT} \div 3600 \text{ seconds}\}$$

Where:

- s_i^{RT} : Length of RTD interval i , expressed in seconds;
- $SRes_{hup}^{DA}$: Day Ahead Operating Reserves Service schedule for product p for Supplier u in hour h containing RTD interval i , expressed in MW;
- $REDRes_{iup}$: Adjustment to reflect changes in the Emergency Upper Operating Limit or Normal Upper Operating Limit, whichever is applicable, in the event that Supplier u requests and is granted a derate of its Real-Time Operating Capacity as described in H.10.3 below;
- $SRes_{iup}^{RT}$: the Real-Time Operating Reserve Service scheduled for product p for Supplier u in RTD interval i , expressed in MW;
- $PRes_{iup}^{RT}$: the Real-Time Market Clearing Price for Operating Reserve Service for product p at the location of Supplier u in RTD interval i , expressed in \$/MW;

H.6. Hourly DAMAP for Demand Side Resources

$$\max \left\{ 0, \sum_{i=1}^n \left[\sum_p (CDAMPRes_{iup}) + CDAMPReg_{iu} \right] \right\}$$

Where:

- $CDAMPRes_{iu}$: Operating Reserves Service component of the DAMAP to Supplier u for interval i , determined separately for each Operating Reserves Service product, expressed in \$;
- $CDAMPReg_{iu}$: Regulation Service component of RTD interval i to the DAMAP to Supplier u , expressed in \$;

H.7. RTD Interval Regulation Service Component of DAMAP When Demand Side Resources' Real-Time Regulation Schedules are Different than their DAM Regulation Schedules

H.7.1. Real-Time Regulation Service schedule less than Day-Ahead Regulation Service schedule:

$$CDMAPReg_{iu} = \{[(\{SReg_{hu}^{DA} - REDReg_{iu}\} - SReg_{iu}^{RT}) \times (PReg_{iu}^{RT} - BReg_{hu}^{DA})] \times [s_i^{RT} \div 3600 \text{ seconds}]\} + \{-1 \times RegM_{iu}^{RT}\} \times \max[0, (PRegM_{iu}^{RT} - BRegM_{iu}^{RT})]$$

Where:

- s_i^{RT} : Length of RTD interval i , expressed in seconds;
- $SReg_{hu}^{DA}$: Day Ahead Regulation Service schedule for Supplier u in hour h containing RTD interval i , expressed in MW;
- $REDReg_{iu}$: Adjustment to reflect changes in the Emergency Upper Operating Limit or Normal Upper Operating Limit, whichever is applicable, in the event that Supplier u requests and is granted a derate of its Real-Time Operating Capacity as described in H.10.2 below;
- $SReg_{iu}^{RT}$: the Real-Time Regulation Service scheduled for Supplier u in RTD interval i , expressed in MW;
- $PReg_{iu}^{RT}$: the Real-Time Regulation Capacity Market Price at the location of Supplier u in RTD interval i , expressed in \$/MW;
- $BReg_{hu}^{DA}$: DAM Regulation Capacity Bid price by Supplier u in hour h , expressed in \$/MW;
- $RegM_{iu}^{RT}$: the Real-Time Regulation Movement for Supplier u in RTD interval i , expressed in MW;
- $PRegM_{iu}^{RT}$: Real-Time Regulation Movement Market Price at the location of Supplier u in interval i ;
- $BRegM_{iu}^{RT}$: the Real-Time Regulation Movement Bid price by Supplier u in RTD interval i , expressed in \$/MW;

H.7.2. Real-Time Regulation schedule greater than or equal to Day-Ahead Regulation schedule:

$$CDMAPReg_{iu} = \{[(\{SReg_{hu}^{DA} - REDReg_{iu}\} - SReg_{iu}^{RT}) \times \max(0, \{PReg_{iu}^{RT} - BReg_{iu}^{RT}\})] \times [s_i^{RT} \div 3600 \text{ seconds}]\} + \{-1 \times RegM_{iu}^{RT}\} \times \max[0, (PRegM_{iu}^{RT} - BRegM_{iu}^{RT})]$$

Where:

- s_i^{RT} : Length of RTD interval i , expressed in seconds;
- $SReg_{hu}^{DA}$: Day Ahead Regulation Service schedule for Supplier u in hour h containing RTD interval i , expressed in MW;
- $REDReg_{iu}$: Adjustment to reflect changes in the Emergency Upper Operating Limit or Normal Upper Operating Limit, whichever is applicable, in the event that Supplier u requests

and is granted a derate of its Real-Time Operating Capacity as described in H.10.2 below;

- $SReg_{iu}^{RT}$: the Real-Time Regulation Service scheduled for Supplier u in RTD interval i , expressed in MW;
- $PReg_{iu}^{RT}$: the Real-Time Regulation Capacity Market Price at the location of Supplier u in RTD interval i , expressed in \$/MW;
- $BReg_{iu}^{RT}$: the Real-Time Regulation Capacity Bid price by Supplier u in RTD interval i , expressed in \$/MW;
- $RegM_{iu}^{RT}$: the Real-Time Regulation Movement for Supplier u in RTD interval i , expressed in MW;
- $PRegM_{iu}^{RT}$: the Real-Time Regulation Movement Market Price at the location of Supplier u in interval i ;
- $BRegM_{iu}^{RT}$: the Real-Time Regulation Movement Bid price by Supplier u in RTD interval i , expressed in \$/MW;

H.8. RTD Interval Operating Reserves Component of DAMAP When Demand Side Resources' Real-Time Reserves Schedules for any Operating Reserves Products are Different than their DAM Reserves Schedules

H.8.1. Real-Time Reserves schedules less than Day-Ahead Reserves schedules:

$$CDMAPRes_{iup} = \{[(\{SRes_{hup}^{DA} - REDRes_{iup}\} - SRes_{iup}^{RT}) \times (PRes_{iup}^{RT} - BRes_{hup}^{DA})] \times PIRes_{iu}^{RT}\} \times \{s_i^{RT} \div 3600 \text{ seconds}\}$$

Where:

- s_i^{RT} : Length of RTD interval i , expressed in seconds;
- $SRes_{hup}^{DA}$: Day Ahead Operating Reserves Service schedule for product p for Supplier u in hour h containing RTD interval i , expressed in MW;
- $REDRes_{iup}$: Adjustment to reflect changes in the Emergency Upper Operating Limit or Normal Upper Operating Limit, whichever is applicable, in the event that Supplier u requests and is granted a derate of its Real-Time Operating Capacity as described in H.10.3 below;
- $SRes_{iup}^{RT}$: the Real-Time Operating Reserve Service scheduled for product p for Supplier u in RTD interval i , expressed in MW;
- $PRes_{iup}^{RT}$: the Real-Time Market Clearing Price for Operating Reserve Service for product p at the location of Supplier u in RTD interval i , expressed in \$/MW;
- $BRes_{hup}^{DA}$: Day Ahead Market Availability Bid for Operating Reserves Service Bid for product p by Supplier u in hour h , expressed in \$/MW;
- $PIRes_{iu}$: the Reserve Performance Index in RTD interval i for Demand Side Resource u , expresses as a decimal value between zero and one, as determined in Appendix G;

H.8.2. Real-Time Reserves schedules greater than or equal to Day-Ahead Reserves schedules:

$$CDMAPRes_{iup} = \{[(SRes_{hup}^{DA} - REDRes_{iup}) - SRes_{iup}^{RT}] \times PRes_{iup}^{RT}\} \times PIRes_{iu}^{RT} \times \{s_i^{RT} \div 3600 \text{ seconds}\}$$

Where:

- s_i^{RT} : Length of RTD interval i , expressed in seconds;
- $SRes_{hup}^{DA}$: Day Ahead Operating Reserves Service schedule for product p for Supplier u in hour h containing RTD interval i , expressed in MW;
- $REDRes_{iup}$: Adjustment to reflect changes in the Emergency Upper Operating Limit or Normal Upper Operating Limit, whichever is applicable, in the event that Supplier u requests and is granted a derate of its Real-Time Operating Capacity as described in H.10.3 below;
- $SRes_{iup}^{RT}$: the Real-Time Operating Reserve Service scheduled for product p for Supplier u in RTD interval i , expressed in MW;
- $PRes_{iup}^{RT}$: the Real-Time Market Clearing Price for Operating Reserve Service for product p at the location of Supplier u in RTD interval i , expressed in \$/MW;
- $PIRes_{iu}$: the Reserve Performance Index in RTD interval i for Demand Side Resource u , expresses as a decimal value between zero and one, as determined in Appendix G;

H.9. RTD Interval Regulation Service Component of DAMAP When Limited Energy Storage Resources' Real-Time Regulation Schedules are Different than their DAM Regulation Schedules

H.9.1. Real-Time Regulation Service schedule less than Day-Ahead Regulation Service schedule and Real-Time Regulation Capacity Market Prices greater than Day-Ahead Regulation Capacity Bid price:

$$CDMAPReg_{iu} = \{[(SReg_{hu}^{DA} - REDReg_{iu}) - SReg_{iu}^{RT}] \times (PReg_{iu}^{RT} - BReg_{iu}^{DA})\} \times K_{PI} \times \{s_i^{RT} \div 3600 \text{ seconds}\} + \{-1 \times RegM_{iu}^{RT}\} \times \max[0, (PRegM_{iu}^{RT} - BRegM_{iu}^{RT})]$$

Where:

- s_i^{RT} : Length of RTD interval i , expressed in seconds;
- $SReg_{hu}^{DA}$: Day Ahead Regulation Service schedule for Supplier u in hour h containing RTD interval i , expressed in MW;
- $REDReg_{iu}$: Adjustment to reflect changes in the Emergency Upper Operating Limit or Normal Upper Operating Limit, whichever is applicable, in the event that Supplier u requests and is granted a derate of its Real-Time Operating Capacity as described in H.10.2 below;
- $SReg_{iu}^{RT}$: the Real-Time Regulation Service scheduled for Supplier u in RTD interval i , expressed in MW;

- $PReg_{iu}^{RT}$: the Real-Time Regulation Capacity Market Price at the location of Supplier u in RTD interval i , expressed in \$/MW;
- $BReg_{hu}^{DA}$: DAM Regulation Capacity Bid price by Supplier u in hour h , expressed in \$/MW;
- K_{PJ} : the factor derived from the Regulation Service Performance index for Resource u for RTD interval i , as determined in Appendix G;
- $RegM_{iu}^{RT}$: the Real-Time Regulation Movement for Supplier u in RTD interval i , expressed in MW;
- $PRegM_{iu}^{RT}$: the Real-Time Regulation Movement Market Price at the location of Supplier u in interval i ;
- $BRegM_{iu}^{RT}$: the Real-Time Regulation Movement Bid price by Supplier u in RTD interval i , expressed in \$/MW;

H.9.2. Real-Time Regulation Service schedule less than Day-Ahead Regulation Service schedule and Real-Time Regulation Capacity Market price less than or equal to Day-Ahead Regulation Capacity Bid price:

$$CDMAPReg_{iu} = \{[(\{SReg_{hu}^{DA} - REDReg_{iu}\} - SReg_{iu}^{RT}) \times (PReg_{iu}^{RT} - BReg_{hu}^{DA})] \times [s_i^{RT} \div 3600 \text{ seconds}]\} + \{[-1 \times RegM_{iu}^{RT}] \times \max[0, (PRegM_{iu}^{RT} - BRegM_{iu}^{RT})]\}$$

Where:

- s_i^{RT} : Length of RTD interval i , expressed in seconds;
- $SReg_{hu}^{DA}$: Day Ahead Regulation Service schedule for Supplier u in hour h containing RTD interval i , expressed in MW;
- $REDReg_{iu}$: Adjustment to reflect changes in the Emergency Upper Operating Limit or Normal Upper Operating Limit, whichever is applicable, in the event that Supplier u requests and is granted a derate of its Real-Time Operating Capacity as described in H.10.2 below;
- $SReg_{iu}^{RT}$: the Real-Time Regulation Service scheduled for Supplier u in RTD interval i , expressed in MW;
- $PReg_{iu}^{RT}$: the Real-Time Regulation Capacity Market Price at the location of Supplier u in RTD interval i , expressed in \$/MW;
- $BReg_{hu}^{DA}$: DAM Regulation Capacity Bid price by Supplier u in hour h , expressed in \$/MW;
- $RegM_{iu}^{RT}$: the Real-Time Regulation Movement for Supplier u in RTD interval i , expressed in MW;
- $PRegM_{iu}^{RT}$: the Real-Time Regulation Movement Market Price at the location of Supplier u in interval i ;
- $BRegM_{iu}^{RT}$: the Real-Time Regulation Movement Bid price by Supplier u in RTD interval i , expressed in \$/MW;

H.9.3. Real-Time Regulation Service schedule greater than or equal to Day-ahead Regulation Service schedule:

$$CDMAPreg_{iu} = \{ \{ (SReg_{hu}^{DA} - REDReg_{iu}) - SReg_{iu}^{RT} \} \times \max(0, \{ PReg_{iu}^{RT} - BReg_{iu}^{RT} \}) \times [s_i^{RT} \div 3600 \text{ seconds}] \} + \{ [-1 \times RegM_{iu}^{RT}] \times \max[0, (PRegM_{iu}^{RT} - BRegM_{iu}^{RT})] \}$$

Where:

- s_i^{RT} : Length of RTD interval i , expressed in seconds;
- $SReg_{hu}^{DA}$: Day Ahead Regulation Service schedule for Supplier u in hour h containing RTD interval i , expressed in MW;
- $REDReg_{iu}$: Adjustment to reflect changes in the Emergency Upper Operating Limit or Normal Upper Operating Limit, whichever is applicable, in the event that Supplier u requests and is granted a derate of its Real-Time Operating Capacity as described in H.10.2 below;
- $SReg_{iu}^{RT}$: the Real-Time Regulation Service scheduled for Supplier u in RTD interval i , expressed in MW;
- $PReg_{iu}^{RT}$: the Real-Time Regulation Capacity Market Price at the location of Supplier u in RTD interval i , expressed in \$/MW;
- $BReg_{iu}^{RT}$: the Real-Time Regulation Capacity Bid price by Supplier u in RTD interval i , expressed in \$/MW;
- $RegM_{iu}^{RT}$: the Real-Time Regulation Movement for Supplier u in RTD interval i , expressed in MW;
- $PRegM_{iu}^{RT}$: Real-Time Regulation Movement Market Price at the location of Supplier u in interval i ;
- $BRegM_{iu}^{RT}$: the Real-Time Regulation Movement Bid price by Supplier u in RTD interval i , expressed in \$/MW;

H.10. Adjustments to Suppliers' DAM Energy, Regulation, and Operating Reserves Schedules Used for DAMAP Resulting from Supplier Requested Derates of Real-Time Operating Capacity

H.10.1. DAM Energy Schedules

$$REDen_{iu} = \left\{ \left(\frac{POTREDen_{iu}}{POTREDen_{iu} + POTREDreg_{iu} + \sum_p POTREDres_{iup}} \right) \times REDtot_{iu} \right\}$$

Where:

- $POTREDen_{iu}$: the potential amount that the Day-Ahead Energy schedule (SEn_{hu}^{DA}) could be reduced for the purposes of computing DAMAP to account for a derate of Operating Capacity for Supplier u in RTD interval i , expressed in MW, computed as;

$$POTREDen_{iu} = \max\{0, SEN_{hu}^{DA} - SEN_{iu}^{RT}\}$$

Where:

SEn_{hu}^{DA} : Day-Ahead scheduled Energy for Supplier u in hour h containing RTD interval i , expressed in MW;

SEn_{iu}^{RT} : the Real-Time Energy scheduled for Supplier u in RTD interval i , computed as the arithmetic average of the six-second AGC Base Point Signals sent to Supplier u during the course of RTD interval i , expressed in MW;

$$POTREDreg_{iu} = \max\{0, SReg_{hu}^{DA} - SReg_{iu}^{RT}\};$$

$SReg_{hu}^{DA}$: Day Ahead Regulation Service schedule for Supplier u in hour h containing RTD interval i , expressed in MW;

$SReg_{iu}^{RT}$: the Real-Time Regulation Service scheduled for Supplier u in RTD interval i , expressed in MW;

$$POTREDres_{iup} = \max\{0, SRes_{hup}^{DA} - SRes_{iup}^{RT}\}$$

$SRes_{hup}^{DA}$: Day Ahead Operating Reserves Service schedule for product p for Supplier u in hour h containing RTD interval i , expressed in MW;

$SRes_{iup}^{RT}$: the Real-Time Operating Reserve Service scheduled for product p for Supplier u in RTD interval i , expressed in MW;

$$REDtot_{iu} = \max\{0, SEn_{hu}^{DA} + SReg_{hu}^{DA} + \sum_p SRes_{hup}^{DA} - UOL_{iu}^{RT}\};$$

UOL_{iu}^{RT} : the Real-Time Emergency Upper Operating Limit or Normal Upper Operating Limit, whichever is applicable, of Supplier u in RTD interval i , expressed in MW;

H.10.2. Regulation Schedules

$$REDreg_{iu} = \left\{ \left(\frac{POTREDreg_{iu}}{POTREDen_{iu} + POTREDreg_{iu} + \sum_p POTREDres_{iup}} \right) \times REDtot_{iu} \right\}$$

Where:

$POTREDreg_{iu}$: the potential amount that the Day-Ahead Market Regulation Service schedule ($SReg_{hu}^{DA}$) could be reduced for the purposes of computing DAMAP to account for a derate of Operating Capacity for Supplier u in RTD interval i , expressed in MW, computed as

$$POTREDreg_{iu} = \max\{0, SReg_{hu}^{DA} - SReg_{iu}^{RT}\}$$

Where:

$SReg_{hu}^{DA}$: Day Ahead Regulation Service schedule for Supplier u in hour h containing RTD interval i , expressed in MW;

$SReg_{iu}^{RT}$: the Real-Time Regulation Service scheduled for Supplier u in RTD interval i , expressed in MW;

$$POTREDen_{iu} = \max\{0, SEn_{hu}^{DA} - SEn_{iu}^{RT}\};$$

- SEn_{hu}^{DA} : Day-Ahead scheduled Energy for Supplier u in hour h containing RTD interval i , expressed in MW;
- SEn_{iu}^{RT} : the Real-Time Energy scheduled for Supplier u in RTD interval i , computed as the arithmetic average of the six-second AGC Base Point Signals sent to Supplier u during the course of RTD interval i , expressed in MW;
- $POTREDres_{iup} = \max\{0, SRes_{hup}^{DA} - SRes_{iup}^{RT}\}$
- $SRes_{hup}^{DA}$: Day Ahead Operating Reserves Service schedule for product p for Supplier u in hour h containing RTD interval i , expressed in MW;
- $SRes_{iup}^{RT}$: the Real-Time Operating Reserve Service scheduled for product p for Supplier u in RTD interval i , expressed in MW;
- $REDtot_{iu} = \max\{0, SEN_{hu}^{DA} + SReg_{hu}^{DA} + \sum_p SRes_{hup}^{DA} - UOL_{iu}^{RT}\}$;
- UOL_{iu}^{RT} : the Real-Time Emergency Upper Operating Limit or Normal Upper Operating Limit, whichever is applicable, of Supplier u in RTD interval i , expressed in MW;

H.10.3. Operating Reserves Schedules

$$REDres_{iup} = \left\{ \left(\frac{POTREDres_{iup}}{POTREDen_{iu} + POTREDreg_{iu} + \sum_p POTREDres_{iup}} \right) \times REDtot_{iu} \right\}$$

Where:

$POTREDres_{iup}$: the potential amount that the DAM Operating Reserves Service schedule. ($DASres_{hup}$) could be reduced for Operating Reserves product p [i.e., 10-Minute Synchronous, 10-Minute Non-Synchronous, and 30-Minute Reserves] for the purposes of computing DAMAP to account for a derate of Operating Capacity for Supplier u in RTD interval i , expressed in MW; computed as

$$POTREDres_{iup} = \max\{0, SRes_{hup}^{DA} - SRes_{iup}^{RT}\}$$

Where:

- $SRes_{hup}^{DA}$: Day Ahead Operating Reserves Service schedule for product p for Supplier u in hour h containing RTD interval i , expressed in MW;
- $SRes_{iup}^{RT}$: the Real-Time Operating Reserve Service scheduled for product p for Supplier u in RTD interval i , expressed in MW;

$$POTREDen_{iu} = \max\{0, SEN_{hu}^{DA} - SEN_{iu}^{RT}\};$$

SEn_{hu}^{DA} : Day-Ahead scheduled Energy for Supplier u in hour h containing RTD interval i , expressed in MW;

SEn_{iu}^{RT} : the Real-Time Energy scheduled for Supplier u in RTD interval i , computed as the arithmetic average of the six-second AGC Base Point Signals sent to Supplier u during the course of RTD interval i , expressed in MW;

$$POTREDreg_{iu} = \max\{0, SReg_{hu}^{DA} - SReg_{iu}^{RT}\};$$

$SReg_{hu}^{DA}$: Day Ahead Regulation Service schedule for Supplier u in hour h containing RTD interval i , expressed in MW;

$SReg_{iu}^{RT}$: the Real-Time Regulation Service scheduled for Supplier u in RTD interval i , expressed in MW;

$$REDtot_{iu} = \max\{0, SEN_{hu}^{DA} + SReg_{hu}^{DA} + \sum_p SRes_{hup}^{DA} - UOL_{iu}^{RT}\};$$

UOL_{iu}^{RT} : the Real-Time Emergency Upper Operating Limit or Normal Upper Operating Limit, whichever is applicable, of Supplier u in RTD interval i , expressed in MW;

:

Appendix I. Ancillary Services Supplier Settlements

I.1. Voltage Support Service Supplier Settlement

I.1.1. Generators under contract to supply Installed Capacity

$$\sum_{h=1}^N \left\{ \left[\left(VSSR \times \frac{MVA_r_g^{TST}}{M} \right) \div N \right] \times 1 \text{ hour} \right\}$$

Where:

- M : Number of months in a year, expressed as Months/Year;
- N : Number of hours in the month, expressed in terms of Hours/Month;
- $VSSR$: Annual Voltage Support Service Rate established through Rate Schedule 2 (Section 15.2) of the Market Administration and Control Area Services Tariff (Services Tariff), expressed in terms of \$/MVA_r/Year;
- $MVA_r_g^{TST}$: Reactive Power Capability for Generator g , as determined through annual performance testing, expressed in terms of Megavars;

I.1.2. Generators not under contract to supply Installed Capacity

$$\sum_{h=1}^N \left\{ \left[\left(VSSR \times \frac{MVA_r_g^{TST}}{M} \right) \div N \right] \times [SVC_{gh}^{RT} \div 3600] \right\}$$

Where:

- M : Number of months in a year, expressed as Months/Year;
- N : Number of hours in the month, expressed in terms of Hours/Month;
- $VSSR$: Annual Voltage Support Service Rate established through Rate Schedule 2 (Section 15.2) of the Market Administration and Control Area Services Tariff (Services Tariff), expressed in terms of \$/MVA_r/Year;
- $MVA_r_g^{TST}$: Reactive Power Capability for Generator g , as determined through annual performance testing, expressed in terms of Megavars;
- SVC_{gh}^{RT} : Time in hour h that Generator g was in-service, expressed in seconds per hour, or 3600 if Generator g was operated Out of Merit during hour h .

I.1.3. Cross Sound Cable/ CHPE MTF (if participating as Voltage Support Suppliers)

$$\left\{ MVA_r_c^{TST} \times \frac{VSSR}{M} \right\} \times \{SVC_{cm}^{RT} \div N\}$$

Where:

- M:** Number of months in a year, expressed as Months/Year;
- N:** Number of seconds in the month, expressed in terms of seconds/Month;
- VSSR:** Annual Voltage Support Service Rate established through Rate Schedule 2 (Section 15.2) of the Market Administration and Control Area Services Tariff (Services Tariff), expressed in terms of \$/MVar/Year;
- $MVar_c^{TST}$:** Reactive Power Capability for Cross Sound Cable or the CHPE MTF c , as determined through annual performance testing, expressed in terms of MVars;
- SVC_{cm}^{RT} :** Time in month m that Cross Sound Cable or the CHPE MTF was open, expressed in seconds per month.

1.2. Voltage Support Service Supplier Lost Opportunity Cost Settlement

If Generator g is eligible and qualified to provide Voltage Support Service and is Out of Merit to provide “ISO Voltage Support” or “TO Voltage Support” (OOM Codes 23 and 24, respectively, per Appendix C), but its Real Time output, AGC instruction, and DA Energy schedule are greater than its Economic Operating Point its settlement will be \$0.00. Otherwise

$$\sum_{i=1}^N \{ \text{Max} [(\{ EOP_{gi}^{RT} - \max [AGC_{gi}^{RT}, EI_{gi}^{RT}, EH_{gh}^{DA}] \} \times \{ LBMPe_{gi}^{RT} + LBMPi_{gi}^{RT} - LBMPc_{gi}^{RT} \}) - LOC_{gi}^{RT}], 0 \} \\ \times s_i^{RT} \div 3600 \text{ seconds}$$

Where:

- N:** Number of RTD intervals in the hour;
- s_i^{RT} :** Length of RTD interval i , expressed in seconds;
- EOP_{gi}^{RT} :** Economic Operating Point for Generator g over RTD interval i , computed as described in Appendix F, expressed in MW;
- EH_{gh}^{DA} :** Energy scheduled Day-Ahead to be produced by Generator g in hour h containing RTD interval i , expressed in MW;
- EI_{gi}^{RT} :** Real-Time output of Generator g over RTD interval i , expressed in MW;
- AGC_{gi}^{RT} :** Average Desired Generation in real-time for Generator g over RTD interval i as instructed to provide Voltage Support Service, expressed in MW;
- $LBMPe_{gi}^{RT}$:** Energy component of the Real-Time LBMP at Generator g 's bus in RTD interval i , expressed in \$/MWh;
- $LBMPi_{gi}^{RT}$:** Losses component of the Real-Time LBMP at Generator g 's bus in RTD interval i , expressed in \$/MWh;
- $LBMPc_{gi}^{RT}$:** Congestion component of the Real-Time LBMP at Generator g 's bus in RTD interval i , expressed in \$/MWh;

The Energy revenue foregone by Generator g as a result of being instructed to reduce its Energy output to provide Voltage Support Service, before adjustments to recognize avoided costs from

reducing its output, is seen as the green shaded portion of the Real-Time generation bid curve graph below. The applicable portion of the calculation is shown below.

$$\{EOP_{gi}^{RT} - \max[AGC_{gi}^{RT}, EI_{gi}^{RT}, EH_{gh}^{DA}]\} \times \{LBMPe_{gi}^{RT} + LBMPi_{gi}^{RT} - LBMPc_{gi}^{RT}\}$$

The *max* term represents the value used for the “New Dispatch Point” in the illustration:

RTD VSS Lost Opportunity Cost Revenue (\$/Hr)

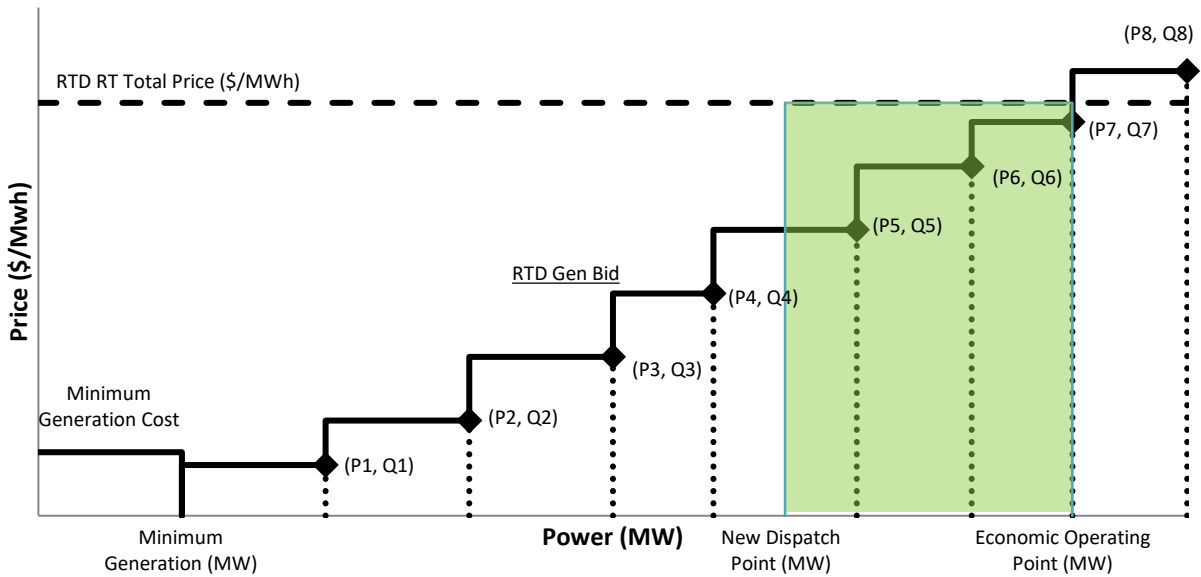

LOC_{gi}^{RT} : Costs avoided by Generator *g* from being instructed to reduce its Energy output to provide Voltage Support Service, calculated as follows:

$$\int_{RTD\ New\ Dispatch\ Point\ (MW)}^{EOP\ (MW)} RTD\ Gen\ Bid$$

Depicted in the Real-Time generation bid curve graph below:

RTD VSS Lost Opportunity Cost (\$/Hr)

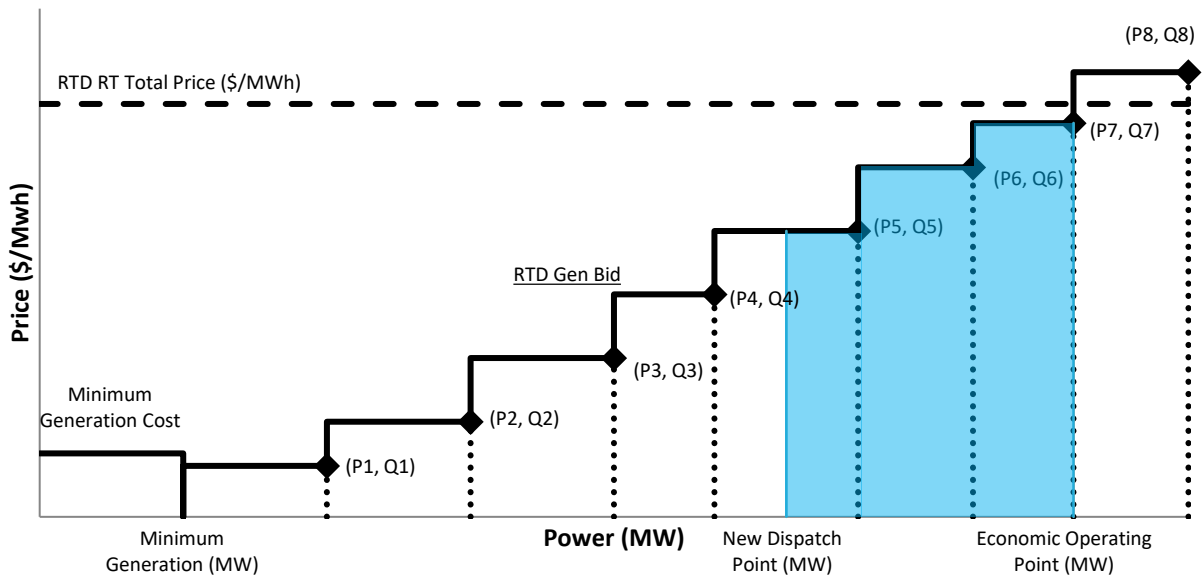

1.3. Regulation and Frequency Response Service Day-Ahead Market Settlement

$$\sum_{h=1}^N \{REGCMW_{gh}^{DA} \times REGCMP_h^{DA}\}$$

Where:

N : Number of hours in the Dispatch Day;

$REGCMW_{gh}^{DA}$: Regulation Service scheduled day-ahead for Generator g for hour h , expressed in terms of MW;

$REGCMP_h^{DA}$: Regulation Capacity Market Price established day-ahead for hour h , expressed in terms of \$/MW;

1.4. Regulation and Frequency Response Service Real-Time Balancing Market Settlement

1.4.1. Real-Time Regulation Capacity Balancing Payment

$$\sum_{i=1}^N \{((REGCMW_{gi}^{RT} - REGCMW_{gi}^{DA}) \times REGCMP_i^{RT}) \times (s_i^{RT} \div 3600 \text{ seconds})\}$$

Where:

N : Number of RTD intervals in the hour;

- s_i^{RT} : Length of RTD interval i , expressed in seconds;
- $REGCMW_{gi}^{DA}$: Regulation Capacity scheduled Day-Ahead for Generator g for hour h , which contains RTD interval i , expressed in terms of MW;
- $REGCMW_{gi}^{RT}$: Regulation Capacity scheduled in real-time for Generator g over RTD interval i , expressed in terms of MW;
- $REGCMP_i^{RT}$: Real-Time Regulation Capacity Market Price in RTD interval i , expressed in terms of \$/MW;

1.4.2. Real Time Regulation Movement Payment

$$\sum_{i=1}^N \{ (REGMMW_{gi}^{RT} \times PiReg_{gi}^{RT}) \times REGMMP_i^{RT} \}$$

Where:

- N : Number of RTD intervals in the hour;
- $REGMMW_{gi}^{RT}$: Regulation Movement instructed for Regulation Service Provider g over RTD interval i , expressed in terms of MW;
- $PiReg_{gi}^{RT}$: Performance Index calculated for that Regulation Service provider g over RTD interval i , computed as described in Appendix G;
- $REGMMP_i^{RT}$: Real-Time Regulation Movement Market Price in RTD interval i , expressed in terms of \$/MW

1.5. Performance-Based Charge to Suppliers of Regulation Service

$$\begin{aligned} & \{ [(1 - PI_{gi}) \times IRCMW_{gi}^{RT}] \times (-1.1 \times REGCMP_i^{RT}) \} \\ & + [(1 - PI_{gi}) \times \{ REGCMW_{gi}^{RT} - IRCMW_{gi}^{RT} \} \times \{-1.1\}] \\ & \times \text{Max}(REGCMP_h^{DA}, REGCMP_i^{RT}) \} \times \{ s_i^{RT} \div 3600 \text{ seconds} \} \end{aligned}$$

Where:

- s_i^{RT} : Length of RTD interval i , expressed in seconds;
- PI_{gi} : Performance Index calculated for Regulation Service provider g for RTD interval i ;
- $IRCMW_{gi}^{RT}$: Incremental Regulation Capacity offered by Regulation Service provider g and selected by the NYISO in the Real-Time Market in RTD interval i which is in excess of Regulation Capacity offered and selected by the NYISO in the Day-Ahead Market for the hour that includes interval i , expressed in MW;
- $REGCMW_{gi}^{RT}$: Regulation Capacity offered by Regulation Service provider g and selected by the NYISO in the Real-Time Market in RTD interval i , expressed in MW;
- $REGCMP_i^{RT}$: Real-Time Regulation Capacity Market Price in RTD interval i , expressed in terms of \$/MW;

$REGCMP_h^{DA}$: Day-Ahead Regulation Capacity Market Price for hour h that includes RTD interval i , expressed in terms of \$/MW.

1.6. Regulation Revenue Adjustment Settlement

1.6.1. Regulation Up ($AGC > RTD$)

$$\sum_{i=1}^N \left\{ \left[\left(\int_{RTD_{gi}^{RT}}^{\min(AGC_{gi}^{RT}, EI_{gi}^{RT})} BID_{gi}^{RT} \right) - (\{LBMPe_{gi}^{RT} + LBMPl_{gi}^{RT} - LBMP_{gi}^{RT}\} \times \{\min[AGC_{gi}^{RT}, EI_{gi}^{RT}] - RTD_{gi}^{RT}\}) \right] \times [s_i^{RT} \div 3600 \text{ seconds}] \right\}$$

Where:

- N : Number of RTD intervals in the hour;
- s_i^{RT} : Length of RTD interval i , expressed in seconds;
- EI_{gi}^{RT} : Real-Time output of Generator g over RTD interval i , expressed in MW;
- AGC_{gi}^{RT} : Average Desired Generation in real-time for Generator g over RTD interval i , as instructed to provide Regulation Service, expressed in MW;
- RTD_{gi}^{RT} : Ramped Base Point in real-time for Generator g over RTD interval i , expressed in MW;
- $LBMPe_{gi}^{RT}$: Energy component of the Real-Time LBMP at Generator g 's bus in RTD interval i , expressed in \$/MWh;
- $LBMPl_{gi}^{RT}$: Losses component of the Real-Time LBMP at Generator g 's bus in RTD interval i , expressed in \$/MWh;
- $LBMPc_{gi}^{RT}$: Congestion component of the Real-Time LBMP at Generator g 's bus in RTD interval i , expressed in \$/MWh;
- BID_{gi}^{RT} : Generator g 's actual Bid or, when the Generator's actual Bid exceeds the total LBMP, this will be set equal to the lesser of the Generator's actual Bid or its reference Bid plus \$100/MWh.

1.6.2. Regulation Down (AGC < RTD)

$$\sum_{i=1}^N \left\{ -1 \times \left[\left(\int_{\max(AGC_{gi}^{RT}, EI_{gi}^{RT})}^{RTD_{gi}^{RT}} BID_{gi}^{RT} \right) - \left(\{LBMPe_{gi}^{RT} + LBMPl_{gi}^{RT} - LBMPc_{gi}^{RT}\} \times \{RTD_{gi}^{RT} - \max[AGC_{gi}^{RT}, EI_{gi}^{RT}]\} \right) \right] \times [s_i^{RT} \div 3600 \text{ seconds}] \right\}$$

Where:

- N : Number of RTD intervals in the hour;
- s_i^{RT} : Length of RTD interval i , expressed in seconds;
- EI_{gi}^{RT} : Real-Time output of Generator g over RTD interval i , expressed in MW;
- AGC_{gi}^{RT} : Average Desired Generation in real-time for Generator g over RTD interval i , as instructed to provide Regulation Service, expressed in MW;
- RTD_{gi}^{RT} : Ramped Base Point in real-time for Generator g over RTD interval i , expressed in MW;
- $LBMPe_{gi}^{RT}$: Energy component of the Real-Time LBMP at Generator g 's bus in RTD interval i , expressed in \$/MWh;
- $LBMPl_{gi}^{RT}$: Losses component of the Real-Time LBMP at Generator g 's bus in RTD interval i , expressed in \$/MWh;
- $LBMPc_{gi}^{RT}$: Congestion component of the Real-Time LBMP at Generator g 's bus in RTD interval i , expressed in \$/MWh;
- BID_{gi}^{RT} : Generator g 's actual bid or, when the Generator's actual Bid is lower than the total LBMP, this will be set equal to the higher of the Generator's actual Bid or its reference Bid minus \$100/MWh.

1.7. Under Generation Penalty Settlement

$$\sum_{i=1}^N \{ [\max(\{PLU_{gi}^{RT} - EI_{gi}^{RT}\}, 0) \times REGMCP_{gi}^{RT}] \times (s_i^{RT} \div 3600 \text{ seconds}) \}$$

Where:

- N : Number of RTD intervals in the hour;
- s_i^{RT} : Length of RTD interval i , expressed in seconds;

PLU_{gi}^{RT} : Penalty Limit for Under Generation for Generator g over RTD interval i , expressed in MW calculated as follows:

$$PLU_{gi}^{RT} = \max[\min(\{AGC_{gi}^{RT} - CET_{gi}^{RT}\}, \{[900 \times PLU_{g(i-1)}^{RT}] + [s_i^{RT} \times (AGC_{gi}^{RT} - CET_{gi}^{RT})]\}) \div \{900 + s_i^{RT}\}, 0]$$

Where:

CET_{gi}^{RT} : 3 % of the Upper Operating Limit of Generator g for RTD interval i , expressed in terms of MW;

AGC_{gi}^{RT} : Average desired generation level (i.e., AGC basepoint) issued to Generator g over RTD interval i , expressed in terms of MW;

$PLU_{g(i-1)}^{RT}$: Penalty Limit for Under-Generation for Generator g for RTD interval $i-1$, or 0 if Generator g has not been running in the last 4 hours

EI_{gi}^{RT} : Real-Time output of Generator g over RTD interval i , expressed in MW;

$REGMCP_{gi}^{RT}$: The greater of the Day-Ahead Regulation Capacity Market Price or the Real-Time Regulation Capacity Market Price for RTD interval i , expressed in terms of \$/MW;

1.8. 10-Minute Synchronous/Spinning Operating Reserve Day-Ahead Market Settlement

$$\sum_{i=1}^N \{(\mathbf{10MN}MW_{gh}^{DA} \times \mathbf{10NM}MCP_h^{DA}) \times \mathbf{1\ hour}\}$$

Where:

N : Number of hours in the Dispatch Day;

$\mathbf{10MN}MW_{gh}^{DA}$: 10-Minute Spinning Reserve scheduled day-ahead for Generator g for hour h , expressed in terms of MW;

$\mathbf{10NM}MCP_h^{DA}$: Applicable Operating Reserve Market Clearing Price for 10-Minute Spinning Reserve established day-ahead for hour h , based upon Generator g 's location with respect to its location in the Eastern, Western, or Southeastern (SENY) regions of the NYCA, expressed in terms of \$/MW;

1.9. 10-Minute Synchronous/Spinning Operating Reserve Real-Time Balancing Market Settlement

$$\sum_{i=1}^N \{[(\mathbf{10MN}MW_{gi}^{RT} - \mathbf{10MN}MW_{gh}^{DA}) \times \mathbf{10NM}MCP_i^{RT}] \times [s_i^{RT} \div \mathbf{3600\ seconds}]\}$$

Where:

N : Number of hours in the Dispatch Day;

s_i^{RT} : Length of RTD interval i , expressed in seconds;

- $10MNMW_{gh}^{DA}$: 10-Minute Spinning Reserve scheduled day-ahead for Generator g for hour h , containing RTD interval i , expressed in terms of MW;
- $10MNMW_{gi}^{RT}$: 10-Minute Spinning Reserve scheduled in real-time for Generator g over RTD interval i , expressed in terms of MW;
- $10NMCP_i^{RT}$: Applicable Operating Reserve Market Clearing Price for 10-Minute Spinning Reserve established in real-time for hour h , containing RTD interval i , based upon Generator g 's location with respect to its location in the Eastern, Western, or Southeastern (SENY) regions of the NYCA, or any applicable Scarcity Reserve Region (s), expressed in terms of \$/MW;

1.10. 10-Minute Non-Synchronous/Spinning Operating Reserve Day-Ahead Market Settlement

$$\sum_{i=1}^N \{ (10NONMW_{gh}^{DA} \times 10NONMCP_h^{DA}) \times 1 \text{ hour} \}$$

Where:

- N : Number of hours in the Dispatch Day;
- $10NONMW_{gh}^{DA}$: 10-Minute Non-Synchronous Reserve scheduled day-ahead for Generator g for hour h , expressed in terms of MW;
- $10NONMCP_h^{DA}$: Applicable Operating Reserve Market Clearing Price for 10-Minute Non-Synchronous Reserve established day-ahead for hour h , based upon Generator g 's location with respect to its location in the Eastern, Western, or Southeastern (SENY) regions of the NYCA, expressed in terms of \$/MW;

1.11. 10-Minute Non-Synchronous/Spinning Operating Reserve Real-Time Balancing Market Settlement

$$\sum_{i=1}^N \{ [(10NONMW_{gi}^{RT} - 10NONMW_{gh}^{DA}) \times 10NONMCP_i^{RT}] \times [s_i^{RT} \div 3600 \text{ seconds}] \}$$

Where:

- N : Number of hours in the Dispatch Day;
- s_i^{RT} : Length of RTD interval i , expressed in seconds;
- $10NONMW_{gh}^{DA}$: 10-Minute Non-Synchronous Reserve scheduled day-ahead for Generator g for hour h , containing RTD interval i , expressed in terms of MW;
- $10NONMW_{gi}^{RT}$: 10-Minute Non-Synchronous Reserve scheduled in real-time for Generator g over RTD interval i , expressed in terms of MW;
- $10NONMCP_i^{RT}$: Applicable Operating Reserve Market Clearing Price for 10-Minute Non-Synchronous Reserve established in real-time for hour h , containing RTD interval i , based upon Generator g 's location with respect to its location in the Eastern,

Western, or Southeastern (SENY) regions of the NYCA, or any applicable Scarcity Reserve Region(s), expressed in terms of \$/MW;

1.12. 30-Minute Operating Reserve Day-Ahead Market Settlement

$$\sum_{i=1}^N \{ (30MNMW_{gh}^{DA} \times 30MNMCP_h^{DA}) \times 1 \text{ hour} \}$$

Where:

- N : Number of hours in the Dispatch Day;
- $30MNMW_{gh}^{DA}$: 30-Minute Operating Reserve scheduled day-ahead for Generator g for hour h , expressed in terms of MW;
- $30MNMCP_h^{DA}$: Applicable Operating Reserve Market Clearing Price for 30-Minute Operating Reserve established day-ahead for hour h , based upon Generator g 's location with respect to its location in the Eastern, Western, or Southeastern (SENY) regions of the NYCA, expressed in terms of \$/MW;

1.13. 30-Minute Operating Reserve Real-Time Balancing Market Settlement

$$\sum_{i=1}^N \{ [(30MNMW_{gi}^{RT} - 30MNMW_{gh}^{DA}) \times 30MNMCP_i^{RT}] \times [s_i^{RT} \div 3600 \text{ seconds}] \}$$

Where:

- N : Number of hours in the Dispatch Day;
- s_i^{RT} : Length of RTD interval i , expressed in seconds;
- $30MNMW_{gh}^{DA}$: 30-Minute Operating Reserve scheduled day-ahead for Generator g for hour h , containing RTD interval i , expressed in terms of MW;
- $30MNMW_{gi}^{RT}$: 30-Minute Operating Reserve scheduled in real-time for Generator g over RTD interval i , expressed in terms of MW;
- $30MNMCP_i^{RT}$: Applicable Operating Reserve Market Clearing Price for 30-Minute Operating Reserve established in real-time for hour h , containing RTD interval i , based upon Generator g 's location with respect to its location in the Eastern, Western, or Southeastern (SENY) regions of the NYCA, or any applicable Scarcity Reserve Region(s), expressed in terms of \$/MW;

1.14. Quick Start Reserves Service Settlement

$$\sum_{h=1}^N \{ [C_h \times ((0.85 \times 10NONMCP_{gh}^{DA}) + (0.15 \times 30MNMCP_h^{DA}))] - [Q_h \times 30MNMCP_h^{DA}] \}$$

Where:

- N : Number of hours in the Dispatch Day in which the block of Generator units provided Quick Start Reserves, unless the block of Generator units provided Energy during the hour;
- h : An hour in which the block of Generator units provided Quick Start Reserves, unless the block of Generator units produced Energy during the hour
- C_h : Capacity in MWs of Hour-Ahead Bids for Energy for the block of Generator units
- $10NONMCP_{gh}^{DA}$: Price of 10-Minute NSR (for the applicable Load Zone) in the Day-Ahead Market
- $30MNMCP_h^{DA}$: Price of 30-Minute Reserves (for the applicable Load Zone) in the Day-Ahead Market
- Q_h : Quantity of MWs from the block of Generator units accepted into the 30-Minute Reserves market

1.15. Black Start Capability Service Settlement for NYISO Bulk Power System Restoration or Transmission Districts other than Consolidated Edison

$$\sum_{N_m}^N \{ (BSOM_{ga} + BSTN_{ga} + BSTS_{ga}) \div N_y \}$$

Where:

- N_y : Number of days in the previous year from May 1st to April 30th;
- N_m : Number of days in the month;
- a : Annual period ending April 30th
- $BSOM_{ga}$: Capital and fixed operation and maintenance costs associated with only that equipment which provides Black Start and System Restoration Services;
- $BSTN_{ga}$: Annual costs associated with training operators in Black Start and System Restoration Services;
- $BSTS_{ga}$: Annual costs associated with Black Start and System Restoration Services testing in accordance with the NYISO Plan or the plan of an individual Transmission Owner.

1.16. Black Start Capability Service Settlement for Generators Providing Black Start and System Restoration Services under the Consolidated Edison Transmission District as of October 1, 2005

$$\sum_{N_m}^N \{ (BSCE_{ga} + BSCETN_{ga} + BSCETS_{ga}) \div N_y \}$$

Where:

- N_y : Number of days in the previous year from May 1st to April 30th;

- N_m : Number of days in the month;
- a : Annual period ending April 30th
- $BSCE_{ga}$: Annual compensation for Generators providing Black Start and Restoration Services based upon their unit type and level of interconnection Capital, as specified in the table below:

	Steam Turbine	Gas Turbine
138 KV	\$300,000/yr/unit	\$300,000/yr/site
345 KV	\$350,000/yr/unit	\$350,000/yr/site

- $BSCE_{TN_{ga}}$: Annual costs associated with training operators in Black Start and System Restoration Services;
- $BSCE_{TS_{ga}}$: Annual costs associated with Black Start and System Restoration Services testing in accordance with the NYISO Plan or the plan of an individual Transmission Owner.

1.17. Black Start Capability Service Settlement for Generators Providing Black Start and System Restoration Services under the Consolidated Edison Transmission District as of November 1, 2012

$$BSCE_{Act_a} \times \frac{BSCE_{SCap_{ga}} + BSCE_{SOM_{ga}} + BSCE_{ACap_{ga}} + BSCE_{AOM_{ga}}}{BSCE_{Des_a}}$$

Where:

- a : Annual period ending April 30 of the current year
- $BSCE_{Act_a}$: The number of Sole Black Start Units or Black Start Unit Groups designated by Consolidated Edison as participants in the Consolidated Edison Plan excluding any units that have withdrawn or failed a Black Start Capability Test pursuant to Rate Schedule 5 of the Services Tariff
- $BSCE_{SCap_{ga}}$: Annual station-level capital amount for a Sole Black Start Unit or for one unit of a Black Start Unit Group based upon their unit size, as specified in the Station-Level column of the table below expressed in \$
- $BSCE_{ACap_{ga}}$: The sum of annual capital amounts for the remaining units in the Black Start Unit Group based upon the unit sizes, as specified in the Additional Resource column of the table below expressed in \$

<u>Resource Type</u>	<u>Station-level Capital Payment</u>	<u>Additional Resource Capital Payment</u>
<u>MVA < 10</u>	<u>\$21,770</u>	<u>\$10,880</u>
<u>10 < MVA ≤ 60</u>	<u>\$214,570</u>	<u>\$10,880</u>
<u>60 < MVA ≤ 90</u>	<u>\$248,460</u>	<u>\$10,880</u>
<u>90 < MVA ≤ 300, Small Starting Requirement</u>	<u>\$414,980</u>	<u>\$10,880</u>
<u>90 < MVA ≤ 300, Medium Starting Requirement</u>	<u>\$957,920</u>	<u>\$10,880</u>
<u>90 < MVA ≤ 300, Large Starting Requirement</u>	<u>\$1,785,080</u>	<u>\$10,880</u>
<u>300 < MVA, Large Starting Requirement</u>	<u>\$1,833,750</u>	<u>\$32,650</u>

$BSCESOM_{ga}$: Annual station-level operating and maintenance amounts for a Sole Black Start Unit or for one unit of a Black Start Unit Group based on the units size, as specified in the Station-Level column of the table below expressed in \$

$BSCEAOM_{ga}$: The sum of annual operating and maintenance amounts for the remaining units in the Black Start Unit Group based upon the unit sizes, as specified in the Additional Resource column of the table below expressed in \$

<u>Resource Type</u>	<u>Station-level O&M Payment</u>	<u>Additional Resource O&M Payment</u>
<u>MVA < 10</u>	<u>\$22,335</u>	<u>\$6,040</u>
<u>10 < MVA ≤ 60</u>	<u>\$42,295</u>	<u>\$8,200</u>
<u>60 < MVA ≤ 90</u>	<u>\$49,850</u>	<u>\$10,140</u>
<u>90 < MVA ≤ 300, Small Starting Requirement</u>	<u>\$118,255</u>	<u>\$33,665</u>
<u>90 < MVA ≤ 300, Medium Starting Requirement</u>	<u>\$252,265</u>	<u>\$65,600</u>
<u>90 < MVA ≤ 300, Large Starting Requirement</u>	<u>\$388,865</u>	<u>\$65,820</u>
<u>300 < MVA, Large Starting Requirement</u>	<u>\$414,540</u>	<u>\$77,685</u>

$BSCEDes_a$: Number of units in the Sole Black Start Unit or Black Start Unit Group designated by Consolidated Edison as participant in the Consolidated Edison Plan

1.18. Overgeneration Charge

$$\sum_{i=1}^N \{ [\max(\{ [EI_{gi}^{RT} - RTD_{gi}^{RT}] - [UOL_{gi}^{RT} \times 3\%], 0 \}) \times \text{Max}(MPRC_{DAM}, MPRC_{RT})] \times [s_i^{RT} \div 3600 \text{ seconds}] \}$$

Where:

- N : Number of RTD intervals i in the hour;
- EI_{gi}^{RT} : Real-Time output of Generator g over RTD interval i , expressed in MW;
- RTD_{gi}^{RT} : Ramped Base Point in Real-Time for Generator g over RTD interval i , expressed in MW;
- UOL_{gi}^{RT} : Upper Operating Limit of Generator g over RTD interval i , expressed in MW;
- $MPRC_{DAM}$: Regulation Capacity Market Price (\$/MW) which applies to the dispatch interval i in the Day-Ahead market;
- $MPRC_{RT}$: Regulation Capacity Market Price (\$/MW) for RTD interval i in the Real-Time Market; and
- s_i^{RT} : Length of RTD interval i , expressed in seconds.

1.19. Persistent Over-Withdrawal Charges

$$\sum_{i=1}^N \{ [\max(\{ PLO_{gi}^{RT} - EI_{gi}^{RT}, 0 \}) \times REGMCP_{gi}^{RT}] \times (s_i^{RT} \div 3600 \text{ seconds}) \}$$

Where:

- N : Number of RTD intervals in the hour;
- s_i^{RT} : Length of RTD interval i , expressed in seconds;
- PLO_{gi}^{RT} : Penalty Limit for Over withdrawal for Generator g over RTD interval i , expressed in MW calculated as follows:

$$PLO_{gi}^{RT} = \min[\min(\{ AGC_{gi}^{RT} - CET_{gi}^{RT} \}, \{ [900 \times PLO_{g(i-1)}^{RT}] + [s_i^{RT} \times (AGC_{gi}^{RT} - CET_{gi}^{RT})] \}), 0]$$

Where:

- CET_{gi}^{RT} : 3 % of the absolute value of the Lower Operating Limit of Generator g for RTD interval i , expressed in terms of MW;
- AGC_{gi}^{RT} : Average desired generation level (i.e., AGC basepoint) issued to Generator g over RTD interval i , expressed in terms of MW;

- $PLO_{g(i-1)}^{RT}$: Penalty Limit for Over withdrawal for Generator g for RTD interval $i-1$, or 0 if Generator g has not been running in the last 4 hours
- EI_{gi}^{RT} : Real-Time output of Generator g over RTD interval i , expressed in MW;
- $REGMCP_{gi}^{RT}$: The greater of the Day-Ahead Regulation Capacity Market Price or the Real-Time Regulation Capacity Market Price for RTD interval i , expressed in terms of \$/MW;

Appendix J. Energy Purchaser Settlements

J.1. Day-Ahead Energy Settlements for Load Serving Entities and Virtual Load

$$\sum_{h=1}^N \{ [EH_{lh}^{DA} \times (LBMPe_{zh}^{DA} + LBMPl_{zh}^{DA} - LBMPc_{zh}^{DA})] \times 1 \text{ hour} \}$$

Where:

- N : Number of hours in the Dispatch Day
- EH_{lh}^{DA} : Energy scheduled Day-Ahead to be purchased by LSE or Virtual Load Bus l in hour h expressed in terms of MW;
- $LBMPe_{zh}^{DA}$: Energy component of the Day-Ahead LBMP in the load zone z of LSE or Virtual Load Bus l in hour h expressed in \$/MWh;
- $LBMPl_{zh}^{DA}$: Losses component of the Day-Ahead LBMP in the load zone z of LSE or Virtual Load Bus l in hour h expressed in \$/MWh;
- $LBMPc_{zh}^{DA}$: Congestion component of the Day-Ahead LBMP in the load zone z of LSE or Virtual Load Bus l in hour h expressed in \$/MWh;

J.2. Energy Settlements for Day-Ahead LSEs Providing Energy service to Demand Reduction Buses

$$\sum_{h=1}^N \{ [DRH_{rh}^{DA} \times (LBMPe_{bh}^{DA} + LBMPl_{bh}^{DA} - LBMPc_{bh}^{DA})] \times 1 \text{ hour} \}$$

Where:

- N : Number of hours in the Dispatch Day
- DRH_{rh}^{DA} : Demand Reduction scheduled Day-Ahead to be produced by Demand Response Providers' Demand Side Resources r in hour h expressed in terms of MW;
- $LBMPe_{bh}^{DA}$: Energy component of the Day-Ahead LBMP at Demand Side Resource r 's bus b in hour h expressed in \$/MWh;
- $LBMPl_{bh}^{DA}$: Losses component of the Day-Ahead LBMP at Demand Side Resource r 's bus b in hour h expressed in \$/MWh;
- $LBMPc_{bh}^{DA}$: Congestion component of the Day-Ahead LBMP at Demand Side Resource r 's bus b in hour h expressed in \$/MWh;

J.3. Energy Settlements for Real-Time LSEs Providing Energy service to Demand Reduction Buses

$$\sum_{h=1}^N \{ [DRR_{rh}^{DA} \times (LBMPe_{zh}^{DA} + LBMPl_{zh}^{DA} - LBMPc_{zh}^{DA})] \times 1 \text{ hour} \}$$

Where:

- N : Number of hours in the Dispatch Day;
- DRR_{rh}^{RT} : Demand Reduction produced by Demand Response Providers' Demand Side Resources r in hour h , expressed in terms of megawatt hours;
- $RTLBMPe_{zh}$: Energy component of the Hourly Real-Time LBMP at LSE's Load Zone z in hour h expressed in \$/MWh;
- $RTLBMPl_{zh}$: Loss component of the Hourly Real-Time LBMP at LSE's Load Zone z in hour h expressed in \$/MWh;
- $RTLBMPc_{zh}$: Congestion component of the Hourly Real-Time LBMP at LSE's Load Zone z in hour h expressed in \$/MWh;

J.4. Demand Reduction Imbalance Charge to LSEs

If the invoice version is version 1 (i.e., the initial monthly invoicing of a service month) and no Demand Reduction megawatt hour data has been provided by the Meter Services Entity before the initial monthly invoice of the service month, then the Demand Reduction Imbalance Charge for the Demand Reduction Provider is \$0; otherwise:

$$\sum_{h=1}^N \left\{ \left[\max(\min\{DRR_{rh}^{RT}, [DRH_{rh}^{DA} \times 1 \text{ hour}]\}, 0) - (DRH_{rh}^{DA} \times 1 \text{ hour}) \right] \times \left[\max\left(\left(\sum_{i=1}^N [(LBMPe_{rh}^{RT} + LBMPl_{rh}^{RT} - LBMPc_{rh}^{RT}) \times (s_i^{RT} \div 3600 \text{ seconds})] \right), \{LBMPe_{zh}^{DA} + LBMPl_{zh}^{DA} - LBMPc_{zh}^{DA}\} \right) \right] \right\}$$

Where:

- N : Number of hours in the Dispatch Day
- s_i^{RT} : Length of RTD interval i , expressed in hours
- DRH_{rh}^{DA} : Demand Reduction scheduled Day-Ahead to be produced by Demand Response Providers' Demand Side Resources r in hour h expressed in terms of MW;
- DRR_{rh}^{RT} : Demand Reduction produced by Demand Response Providers' Demand Side Resources r in hour h , expressed in terms of megawatt hours;
- $LBMPe_{bh}^{DA}$: Energy component of the Day-Ahead LBMP at Demand Side Resourcer's bus b in hour h expressed in \$/MWh;

- $LBMP_{bh}^{DA}$: Losses component of the Day-Ahead LBMP at Demand Side Resource r 's bus b in hour h expressed in \$/MWh;
- $LBMP_{bh}^{DA}$: Congestion component of the Day-Ahead LBMP at Demand Side Resource r 's bus b in hour h expressed in \$/MWh;

J.5. Real-Time, Balancing Energy Settlements for LSEs and Virtual Load

$$\sum_{h=1}^N \{ [(EB_{li}^{RT} - \{EH_{lh}^{DA} + TH_{lh}^{DA} + TH_{li}^{RT}\}) \times (LBMP_{zi}^{RT} + LBMP_{li}^{RT} - LBMP_{zi}^{RT})] \times [s_i^{RT} \div 3600 \text{ seconds}] \}$$

Where:

- N : Number of hours in the Dispatch Day;
- s_i^{RT} : Length of RTD interval i , expressed in hours;
- EH_{lh}^{DA} : Energy scheduled Day-Ahead to be purchased by LSE or Virtual Load Bus l in hour h containing RTD interval i , expressed in terms of MW;
- TH_{lh}^{DA} : Energy scheduled through Bilateral Transactions Day-Ahead to be withdrawn at LSE or Virtual Bus l in hour h containing RTD interval i , expressed in terms of MW;
- TH_{li}^{RT} : Incremental change in Energy scheduled through Bilateral Transactions after the DAM to be withdrawn at LSE or Virtual Bus l in RTD interval i , expressed in terms of MW;
- $LBMP_{zi}^{RT}$: Energy component of the Real-Time LBMP for the load zone z of LSE or Virtual Load Bus l in hour h containing RTD interval i , expressed in \$/MWh;
- $LBMP_{li}^{RT}$: Losses component of the Real-Time LBMP for the load zone z of LSE or Virtual Load Bus l in hour h containing RTD interval i , expressed in \$/MWh;
- $LBMP_{zi}^{RT}$: Congestion component of the Real-Time LBMP for the load zone z of LSE or Virtual Load Bus l in hour h containing RTD interval i , expressed in \$/MWh;
- EB_{li}^{RT} : Actual Energy Withdrawals by LSE or Virtual Load l in RTD interval i , expressed in terms of megawatts.

J.6. Day-Ahead Energy Settlements for LBMP Market Energy Exports

$$\sum_{h=1}^N \{ [TH_{th}^{DA} \times (LBMP_{bh}^{DA} + LBMP_{bh}^{DA} - LBMP_{bh}^{DA})] \times 1 \text{ hour} \}$$

Where:

- N : Number of hours in the Dispatch Day
- TH_{th}^{DA} : LBMP Market Energy Export Transaction megawatts scheduled Day-Ahead to be exported through Transaction t in hour h , expressed in terms of MW;

- $LBMPe_{bh}^{DA}$: Energy component of the Day-Ahead LBMP at Proxy Generator Bus b , scheduled as the Point of Delivery for LBMP Market Energy Export Transaction t , in hour h expressed in \$/MWh;
- $LBMPl_{bh}^{DA}$: Losses component of the Day-Ahead LBMP at Proxy Generator Bus b , scheduled as the Point of Delivery for LBMP Market Energy Export Transaction t , in hour h , expressed in \$/MWh;
- $LBMPc_{bh}^{DA}$: Congestion component of the Day-Ahead LBMP at Proxy Generator Bus b , scheduled as the Point of Delivery for LBMP Market Energy Export Transaction t , in hour h , expressed in \$/MWh;

J.7. Real-time, Balancing Energy Settlements for LBMP Market Energy Exports

$$\sum_{h=1}^N \{[(TH_{ti}^{RT} - TH_{th}^{DA}) \times (LBMPe_{bi}^{RT} + LBMPl_{bi}^{RT} - LBMPc_{bi}^{RT})] \times [s_i^{RT} \div 3600 \text{ seconds}]\}$$

Where:

- N : Number of RTD intervals i in the day;
- s_i^{RT} : Length of RTD interval i , expressed in seconds;
- TH_{th}^{DA} : LBMP Market Energy Export Transaction megawatts scheduled Day-Ahead to be exported through Transaction t in the hour h containing RTD interval i , expressed in terms of MW;
- TH_{ti}^{RT} : LBMP Market Energy Export Transaction megawatts scheduled in RTD interval i to be exported through Transaction t , expressed in terms of MW;
- $LBMPe_{bi}^{RT}$: Energy component of the Real-Time LBMP at Proxy Generator Bus b , scheduled as the Point of Delivery for LBMP Market Energy Export Transaction t , in RTD interval i , expressed in \$/MW;
- $LBMPl_{bi}^{RT}$: Losses component of the Real-Time LBMP at Proxy Generator Bus b , scheduled as the Point of Delivery for LBMP Market Energy Export Transaction t , in RTD interval i , expressed in \$/MW;
- $LBMPc_{bi}^{RT}$: Congestion component of the Real-Time LBMP at Proxy Generator Bus b , scheduled as the Point of Delivery for LBMP Market Energy Export Transaction t , in RTD interval i , expressed in \$/MW.

J.8. Financial Impact Charge (FIC) for LBMP Exports Failing the NYISO Check-out Process

If Transaction Check-out Failure is under MP Control,

$$\sum_{i=1}^N \{[(TH_{ti}^{RTC} - TH_{ti}^{RT}) \times (s_i^{RT} \div 3600 \text{ seconds})] \times \min[LBMPc_{podti}^{RT}, 0] \times -1\}$$

Otherwise \$0.

Where:

- N : Number of RTD intervals i in the day;
- s_i^{RT} : Length of RTD interval i , expressed in seconds;
- TH_{ti}^{RTC} : LBMP Energy Export Transaction megawatts scheduled by RTC15 for hourly transactions and Rolling RTC for intra-hourly transactions containing RTD interval i to be imported through Transaction t , expressed in terms of MW;
- TH_{ti}^{RT} : LBMP Energy Export Transaction megawatts scheduled in RTD interval i to be imported through Transaction t , expressed in terms of MW;
- $LBMPc_{podti}^{RT}$: Congestion component of the Real-Time LBMP at Proxy Generator Bus pod , scheduled as the Point of Delivery for LBMP Energy Import Transaction t , in RTD interval i , expressed in \$/MW;

Appendix K. Transmission Usage Charge, NTAC, and Trading Hub Settlements

K.1. Day-Ahead Transmission Usage Charge Settlements for Internal, Import, Export, and Wheel Through Bilateral Transactions

K.1.1. Without Grandfathered Transmission Rights

$$\sum_{h=1}^N \{ [TH_{th}^{DA} \times (LBMP_{porh}^{DA} - LBMP_{podh}^{DA})] + [TH_{th}^{DA} \times (LBMP_{porh}^{DA} - LBMP_{podh}^{DA})] \times 1 \text{ hour} \}$$

Where:

- N : Number of hours in the Dispatch Day
- TH_{th}^{DA} : Bilateral Transaction megawatts scheduled Day-Ahead for Transaction t in hour h , expressed in terms of megawatts, with the exception that **Import Bilateral Transactions** are set equal to the Bid megawatts for the Transaction t ;
- $LBMP_{porh}^{DA}$: Losses component of the Day-Ahead LBMP at the bus por , scheduled as the Point of Receipt (Source) of Bilateral Transaction t , in hour h , expressed in \$/MWh;
- $LBMP_{podh}^{DA}$: Losses component of the Day-Ahead LBMP at the bus pod , scheduled as the Point of Delivery (Sink) of Bilateral Transaction t , in hour h , expressed in \$/MWh;
- $LBMP_{porh}^{DA}$: Day-Ahead marginal cost of Congestion at the bus por , scheduled as the Point of Receipt (Source) of Bilateral Transaction t , in hour h , expressed in \$/MWh;
- $LBMP_{podh}^{DA}$: Day-Ahead marginal cost of Congestion at the bus pod , scheduled as the Point of Delivery (Sink) of Bilateral Transaction t , in hour h , expressed in \$/MWh;

Note: This formula would also be used if no congestion exists on the transaction path, the grandfathered transmission right path, or both.

K.1.2. With Grandfathered Transmission Rights

$$\sum_{h=1}^N \{ [TH_{th}^{DA} \times (LBMP_{podh}^{DA} - LBMP_{porh}^{DA})] + [(Max\{[TH_{th}^{DA} - GTRR_{th}^{DA}], 0\}) \times (LBMP_{podh}^{DA} - LBMP_{porh}^{DA})] + GTRC_{th}^{DA} \} \times 1 \text{ hour}$$

Where:

- N : Number of hours in the Dispatch Day
- TH_{th}^{DA} : Bilateral Transaction megawatts scheduled Day-Ahead for Transaction t in hour h , expressed in terms of megawatts, with the exception that **Import Bilateral Transactions** are set equal to the Bid megawatts for the Transaction t ;

- $LBMP_{porh}^{DA}$: Losses component of the Day-Ahead LBMP at the bus por , scheduled as the Point of Receipt (Source) of Bilateral Transaction t , in hour h , expressed in \$/MWh;
- $LBMP_{podh}^{DA}$: Losses component of the Day-Ahead LBMP at the bus pod , scheduled as the Point of Delivery (Sink) of Bilateral Transaction t , in hour h , expressed in \$/MWh;
- $LBMP_{porh}^{DA}$: Day-Ahead marginal cost of Congestion at the bus por , scheduled as the Point of Receipt (Source) of Bilateral Transaction t , in hour h , expressed in \$/MWh;
- $LBMP_{podh}^{DA}$: Day-Ahead marginal cost of Congestion at the bus pod , scheduled as the Point of Delivery (Sink) of Bilateral Transaction t , in hour h , expressed in \$/MWh;
- $GTRR_{th}^{DA}$: Congestion Relief associated with the grandfathered transmission rights for Transaction t , in hour h , expressed in MW. If only one Bilateral Transaction is associated with the grandfathered transmission right, this value will be equal to the grandfathered transmission right megawatts. If more than one Bilateral Transaction is associated with the grandfathered transmission right, this value is computed as follows:

$$\min\{GTR_{gh}^{DA}, [TH_{th}^{DA} \times \min(\{GTR_{gh}^{DA} \div TH_h^{DA}\}, 1.0)]\}$$

Where:

- GTR_{gh}^{DA} : Grandfather transmission right megawatts scheduled Day-Ahead for grandfather transmission right g in hour h , expressed in terms of MW;
- TH_h^{DA} : Bilateral Transaction megawatts scheduled Day-Ahead for all Transaction associated with the grandfathered transmission right g in hour h , expressed in terms of megawatts;
- $GTRC_{th}^{DA}$: Adjustment to congestion relief when the Point of Receipt of the grandfathered right pertains to a Zone rather than Generator Bus. The calculation varies depending on the relationship between the congestion value of the Bilateral Transaction (C) and the GTR (G). The relationships and formulas are as follows:

Case	Conditions	Adjustment to Congestion Relief
1	C=G	ACR = (R*C) – (R*G)
2	C>G C>0 G>0	ACR = (R*C) – (R*G)
3	C<G C>0 G>0	ACR = Max[0, (R*C) – (R*G)]
4	C>G C>0 G<0	ACR = Min[(R*C) – (R*G), (R*C)]
5	C<G C<0 G>0	ACR = Max[(R*C) – (R*G), (R*C)]
6	C<G C<0 G<0	ACR = Max[(R*C) – (R*G), (R*C)]
7	C>G C<0 G<0	ACR = Max[(R*C) – (R*G), (R*C)]

Where:

- ACR : $GTRC_{th}^{DA}$
- C : $LBMP_{podh}^{DA} - LBMP_{porh}^{DA}$
- G : $LBMP_{podgh}^{DA} - LBMP_{porgh}^{DA}$

- R : $GTRR_{th}^{DA}$
- $LBMP_{c_{por}^{DA}gh}$: Day-Ahead marginal cost of Congestion at the bus por , modeled as the Point of Receipt (Source) for grandfathered transmission right g , in hour h , expressed in \$/MWh;
- $LBMP_{c_{pod}^{DA}gh}$: Congestion component of the Day-Ahead LBMP at the bus pod , modeled as the Point of Delivery (Sink) for grandfathered transmission right g , in hour h , expressed in \$/MWh

K.2. Day-Ahead Replacement Energy for Curtailed Import Bilateral Transactions

K.2.1. Suppliers who have signed the Market Service Tariff

$$\sum_{h=1}^N \{ (THBid_{th}^{DA} - TH_{th}^{DA}) \times (LBMPe_{por}^{DA} + LBMPl_{por}^{DA} - LBMPc_{por}^{DA}) \}$$

Where:

- N : Number of hours h in the Dispatch Day;
- TH_{th}^{DA} : Import Transaction megawatts scheduled Day-Ahead to be imported through Transaction t in the hour h , expressed in terms of MW;
- $THBid_{th}^{DA}$: Import Transaction megawatts bid Day-Ahead to be imported through Transaction t in the hour h , expressed in terms of MW;;
- $LBMPe_{por}^{DA}$: Energy component of the Day-Ahead LBMP at the Point of Receipt (Source) Bus por for Import Transaction t , in hour h , expressed in \$/MW;
- $LBMPl_{por}^{DA}$: Losses component of the Day-Ahead LBMP at the Point of Receipt (Source) Bus por for Import Transaction t , in hour h , expressed in \$/MW;
- $LBMPc_{por}^{DA}$: Day-Ahead Marginal Cost of Congestion at the Point of Receipt (Source) Bus por for Import Transaction t , in hour h , expressed in \$/MW.

Note: The Supplier of Energy for the Transaction is the Transmission Customer not the External Generator

K.2.2. Suppliers who have NOT signed the Market Service Tariff

$$\sum_{h=1}^N \{ \max [((THBid_{th}^{DA} - TH_{th}^{DA}) \times \$100), 1.5 \times ((THBid_{th}^{DA} - TH_{th}^{DA}) \times (LBMPe_{por}^{DA} + LBMPl_{por}^{DA} - LBMPc_{por}^{DA}))] \}$$

Where:

- N : Number of hours h in the Dispatch Day;

- TH_{th}^{DA} : Import Transaction megawatts scheduled Day-Ahead to be imported through Transaction t in the hour h , expressed in terms of MW;
- $THBid_{th}^{DA}$: Import Transaction megawatts bid Day-Ahead to be imported through Transaction t in the hour h , expressed in terms of MW;;
- $LBMPe_{porh}^{DA}$: Energy component of the Day-Ahead LBMP at the Point of Receipt (Source) Bus por for Import Transaction t , in hour h , expressed in \$/MW;
- $LBMPl_{porh}^{DA}$: Losses component of the Day-Ahead LBMP at the Point of Receipt (Source) Bus por for Import Transaction t , in hour h , expressed in \$/MW;
- $LBMPc_{porh}^{DA}$: Day-Ahead Marginal Cost of Congestion at the Point of Receipt (Source) Bus por for Import Transaction t , in hour h , expressed in \$/MW.

Note: The Supplier of Energy for the Transaction is the Transmission Customer not the External Generator

K.3. Real-time, Balancing Transmission Usage Charge Settlements for Internal, Import, Export, and Wheel Through Bilateral Transactions

$$\sum_{i=1}^N \{[(TH_{ti}^{RT} - TH_{th}^{DA}) \times (LBMPl_{podi}^{RTC} - LBMPl_{pori}^{RT})] \times [s_i^{RT} \div 3600 \text{ seconds}]\} \\ + \sum_{i=1}^N \{[(TH_{ti}^{RT} - TH_{th}^{DA}) \times (LBMPc_{podi}^{RTC} - LBMPc_{pori}^{RT})] \times [s_i^{RT} \div 3600 \text{ seconds}]\}$$

Where:

- N : Number of RTD intervals i in the day;
- s_i^{RT} : Length of RTD interval i , expressed in hours;
- TH_{th}^{DA} : Bilateral Transaction megawatts scheduled Day-Ahead for Transaction t in hour h containing RTD interval i , expressed in terms of MW;
- TH_{ti}^{RT} : Bilateral Transaction megawatts scheduled in RTD interval i for Transaction t , expressed in terms of megawatts, except as noted below:
- For Import Transactions, it is the bid megawatts for Transaction t ;
 - The amount of Transmission Service scheduled hour-ahead in the RTC for Transactions supplied by one of the following Generators will retroactively be set equal to that Generator's actual output in each RTD interval: (i) Generators providing Energy under contracts executed and effective on or before November 18, 1999 (including PURPA contracts) in which the power purchaser does not control the operation of the supply source but would be responsible for penalties for being off-schedule; (ii) Existing topping turbine Generators and extraction turbine Generators producing electric Energy resulting from the supply of steam to the district steam system located in New York City (LBMP Zone J) in operation on or before November 18, 1999 and/or topping or extraction turbine Generators utilized in replacing or repowering existing steam supplies from such units (in accordance with good

engineering and economic design) that cannot follow schedules, up to a maximum total of 533 MW of such units; and (iii) Existing intermittent (i.e., non-schedulable) renewable resource Generators in operation on or before November 18, 1999 within the NYCA, plus up to an additional 3300 MW of such Generators.

- This procedure will not apply for those hours the Generator supplying that Transaction has bid in a manner that indicates it is available to provide Regulation Service or Operating Reserves.

$LBMP l_{pod}^{RT}$: Losses component of the Real-Time LBMP at Point of Delivery (Sink) Bus pod for Transaction t , in RTD interval i , expressed in \$/MW;

$LBMP l_{por}^{RT}$: Losses component of the Real-Time LBMP at Point of Receipt (Source) Bus por for Transaction t , in RTD interval i , expressed in \$/MW;

$LBMP c_{pod}^{RT}$: Real-Time Marginal Cost of Congestion at Point of Delivery (Sink) Bus pod for Transaction t , in RTD interval i , expressed in \$/MW;

$LBMP c_{por}^{RT}$: Real-Time Marginal Cost of Congestion at Point of Receipt (Source) Bus por for Transaction t , in RTD interval i , expressed in \$/MW;

K.4. Real-Time Replacement Energy for Curtailed Import Bilateral Transactions

K.4.1. Suppliers who have signed the Market Service Tariff

$$\sum_{i=1}^N \{ [(THBid_{ti}^{RT} - TH_{ti}^{RT}) \times (LBMPe_{por}^{RT} + LBMP l_{por}^{RT} - LBMPc_{por}^{RT})] \times [s_i^{RT} \div 3600 \text{ seconds}] \}$$

Where:

N : Number of hours h in the Dispatch Day;

s_i^{RT} : Length of RTD interval (i), expressed in seconds;

TH_{ti}^{RT} : Import Transaction megawatts scheduled by RTC to be imported through Transaction t in RTD interval i , expressed in terms of MW;

$THBid_{ti}^{RT}$: Import Transaction megawatts bid in RTC to be imported through Transaction t in RTD interval i , expressed in terms of MW;

$LBMPe_{por}^{RT}$: Energy component of the Real-Time LBMP at the Point of Receipt (Source) Bus por for Import Transaction t , in RTD interval i , expressed in \$/MW;

$LBMP l_{por}^{RT}$: Losses component of the Real-Time LBMP at the Point of Receipt (Source) Bus por for Import Transaction t , in RTD interval i , expressed in \$/MW;

$LBMPc_{por}^{RT}$: Real-Time marginal cost of Congestion at the Point of Receipt (Source) Bus por for Import Transaction t , in RTD interval i , expressed in \$/MW.

Note: The Supplier of Energy for the Transaction is the Transmission Customer not the External Generator

K.4.2. Suppliers who have NOT signed the Market Service Tariff

$$\sum_{h=1}^N \{ \max [(\{ THBid_{ti}^{RT} - TH_{ti}^{RT} \} \times \$100) \times (s_i^{RT} \div 3600 \text{ seconds}), 1.5 \\ \times (\{ THBid_{ti}^{RT} - TH_{ti}^{RT} \} \times \{ LBMPe_{pori}^{RT} + LBMPl_{pori}^{RT} - LBMPc_{pori}^{RT} \}) \\ \times (s_i^{RT} \div 3600 \text{ seconds})] \}$$

Where:

- N : Number of RTD intervals i in the day;
- s_i^{RT} : Length of RTD interval i , expressed in seconds;
- $THBid_{ti}^{RT}$: Import Transaction megawatts bid in RTC to be imported through Transaction t in the RTD interval i , expressed in terms of MW
- TH_{ti}^{RT} : Import Transaction megawatts scheduled by RTC to be imported through Transaction t in the RTD interval i , expressed in terms of MW;
- $LBMPe_{pori}^{RT}$: Energy component of the Real-Time LBMP at the Point of Receipt (Source) Bus por for Import Transaction t , in RTD interval i , expressed in \$/MW;
- $LBMPl_{pori}^{RT}$: Losses component of the Real-Time LBMP at the Point of Receipt (Source) Bus por for Import Transaction t , in RTD interval i , expressed in \$/MW;
- $LBMPc_{pori}^{RT}$: Real-Time Marginal Cost of congestion at the Point of Receipt (Source) Bus por for Import Transaction t , in RTD interval i , expressed in \$/MW.

Note: The Supplier of Energy for the Transaction is the Transmission Customer not the External Generator

K.5. Financial Impact Charge (FIC) for Import Transactions Failing the NYISO Check-out Process

If Transaction Check -out Failure under MP Control,

$$\sum_{i=1}^N \{ [(TH_{ti}^{RTC} - TH_{ti}^{RT}) \times (s_{ti}^{RT} \div 3600 \text{ seconds})] \times \max [LBMPc_{pori}^{RT}, 0] \}$$

Otherwise \$0.

Where:

- N : Number of RTD intervals i in the day;
- s_{ti}^{RT} : Length of RTD interval i , expressed in seconds;
- TH_{ti}^{RTC} : Import Transaction megawatts scheduled by RTC15 for hourly transactions and Rolling RTC for intra-hourly transactions containing RTD interval i to be imported through Transaction t , expressed in terms of MW;
- TH_{ti}^{RT} : Import Transaction megawatts scheduled in RTD interval i to be imported through Transaction t , expressed in terms of MW;

$LBMPc_{pori}^{RT}$: Congestion component of the Real-Time LBMP at Proxy Generator Bus por , scheduled as the Point of Receipt for LBMP Energy Import Transaction t , in RTD interval i , expressed in \$/MW;

K.6. Financial Impact Charge (FIC) for Export Transactions Failing the NYISO Check-out Process

If Transaction Check -out Failure under MP Control,

$$\sum_{i=1}^N \{ [(TH_{ti}^{RTC} - TH_{ti}^{RT}) \times (s_{ti}^{RT} \div 3600 \text{ seconds})] \times \min[LBMPc_{podti}^{RT}, 0] \times -1 \}$$

Otherwise \$0

Where:

- N : Number of RTD intervals i in the day;
- s_{ti}^{RT} : Length of RTD interval i , expressed in seconds;
- TH_{ti}^{RTC} : Export Transaction megawatts scheduled by RTC15 for hourly transactions and Rolling RTC for intra-hourly transactions containing RTD interval i to be imported through Transaction t , expressed in terms of MW;
- TH_{ti}^{RT} : Export Transaction megawatts scheduled in RTD interval i to be imported through Transaction t , expressed in terms of MW;
- $LBMPc_{podti}^{RT}$: Congestion component of the Real-Time LBMP at Proxy Generator Bus pod , scheduled as the Point of Delivery for LBMP Energy Export Transaction t , in RTD interval i , expressed in \$/MW;

K.7. Financial Impact Charge (FIC) for Wheel Through Transactions Failing the NYISO Check-out Process

If Transaction Check -out Failure under MP Control,

$$\sum_{i=1}^N \{ [(TH_{ti}^{RTC} - TH_{ti}^{RT}) \times (s_{ti}^{RT} \div 3600 \text{ seconds})] \times [\max(LBMPc_{pori}^{RT}, 0) + (\min(LBMPc_{podti}^{RT}, 0) \times -1)] \}$$

Otherwise \$0

Where:

- N : Number of RTD intervals i in the day;
- s_{ti}^{RT} : Length of RTD interval i , expressed in hours;
- TH_{ti}^{RTC} : Wheel Through Transaction megawatts scheduled by RTC15 for hourly transactions and Rolling RTC for intra-hourly transactions containing RTD interval i to be imported through Transaction t , expressed in terms of MW;

- TH_{ti}^{RT} : Wheel Through megawatts scheduled in RTD interval i to be imported through Transaction t , expressed in terms of MW;
- $LBMPc_{porti}^{RT}$: Congestion component of the Real-Time LBMP at Proxy Generator Bus por , scheduled as the Point of Receipt for LBMP Energy Import Transaction t , in RTD interval i , expressed in \$/MW;
- $LBMPc_{podti}^{RT}$: Congestion component of the Real-Time LBMP at Proxy Generator Bus pod , scheduled as the Point of Delivery for LBMP Energy Import Transaction t , in RTD interval i , expressed in \$/MW.

K.8. NTAC on LSE Withdrawals and Exports, LBMP Market Energy Exports, and Wheels Through

$$\sum_{i=1}^N \{ [TH_{th}^{RT} \times NTAC\$_m] + [EB_{bh}^{RT} \times NTAC\$_m] \}$$

Where:

- N : Number of hours h in the day;
- EB_{bh}^{RT} : Actual Energy Withdrawals by LSE Bus b in hour h , expressed in terms of megawatt hours.
- TH_{th}^{RT} : Export, LBMP Market Energy Export, and Wheel Through megawatts scheduled in hour h via Transaction t , expressed in terms of megawatt hours, exclusive of Transactions scheduled with ISO-NE Points of Delivery (Sink);
- $NTAC\$_m$: Monthly NTAC rate, expressed in \$/MWh, as determined in Attachment H of the NYISO OATT;

K.9. Payment to NYPA of NTAC on LSE Withdrawals and Exports, LBMP Market Energy Exports, Wheels Through, and ESR Withdrawals

$$\sum_{i=1}^N \left\{ \sum_{l \in L} NTAC_{hl}^{LSE} + \sum_{c \in C} NTAC_{hc}^{LExp} + \sum_{c \in C} NTAC_{hc}^{Exp} + \sum_{c \in C} NTAC_{hc}^{WT} + \sum_{c \in C} NTAC_{hc}^{ESRSW} \right\}$$

Where:

- C : Set of Transmission Customers c engaged in Export, LBMP Energy Export, and Wheel Through during the month;
- L : Set of LSE Buses l engaged in Energy transactions during the month;
- N : Number of hours h in the month;
- $NTAC_{hl}^{LSE}$: NTAC collected from LSE l in hour h , expressed in \$;
- $NTAC_{hc}^{LExp}$: NTAC collected from Transmission Customer c on LBMP Energy Export Transactions scheduled in hour h , exclusive of transactions with Points of Withdrawal in ISO-NE, expressed in \$;

$NTAC_{hc}^{Exp}$: NTAC collected from Transmission Customer c on Bilateral Export Transactions scheduled in hour h , exclusive of transactions with Points of Withdrawal in ISO-NE, expressed in \$;

$NTAC_{hc}^{WT}$: NTAC collected from Transmission Customer c on Wheel Through Transactions scheduled in hour h , exclusive of transactions with Points of Withdrawal in ISO-NE, expressed in \$.

$NTAC_{hc}^{ESRSW}$: NTAC collected from Energy Storage Resource withdrawals expressed in \$.

K.10. Day-Ahead Energy Settlements at Trading Hub Point of Injection (Source) Buses

$$\sum_{h=1}^N \{ [THE_{th}^{DA} \times (LBMPe_{zh}^{DA} + LBMPl_{zh}^{DA} - LBMPc_{zh}^{DA})] \times 1 \text{ hour} \}$$

Where:

N : Number of hours in the Dispatch Day

THE_{th}^{DA} : Energy scheduled Day-Ahead sourced from Trading Hub th for Bilateral Transaction t , purchased by the Trading Hub Energy Owner in hour h expressed in terms of MW;

$LBMPe_{zh}^{DA}$: Energy component of the Day-Ahead LBMP in the load zone z of Trading Hub th in hour h expressed in terms of \$/MWh;

$LBMPl_{zh}^{DA}$: Losses component of the Day-Ahead LBMP in the load zone z of Trading Hub th in hour h expressed in terms of \$/MWh; and

$LBMPc_{zh}^{DA}$: Day-Ahead Marginal Cost of Congestion in the load zone z of Trading Hub th in hour h expressed in terms of \$/MWh.

K.11. Real-Time Market Energy Settlements at Trading Hub Point of Injection (Source) Buses

$$\sum_{h=1}^N \{ [(THE_{th}^{DA} \times 1 \text{ hour}) - THE_{th}^{RT}] \times (LBMPe_{zh}^{RT} + LBMPl_{zh}^{RT} - LBMPc_{zh}^{RT}) \}$$

Where:

N : Number of hours in the Dispatch Day

THE_{th}^{DA} : Energy scheduled Day-Ahead sourced from Trading Hub th for Bilateral Transaction t , purchased by the Trading Hub Energy Owner in hour h expressed in terms of MW;

THE_{th}^{RT} : Energy scheduled in the Real-Time Market sourced from Trading Hub th for Bilateral Transaction t , purchased by the Trading Hub Energy Owner in hour h expressed in terms of megawatt hours;

$LBMPe_{zh}^{RT}$: Energy component of the hourly integrated Real-Time LBMP in the load zone z of Trading Hub th in hour h expressed in terms of \$/MWh;

$LBMP_{zh}^{RT}$: Losses component of the hourly integrated Real-Time LBMP in the load zone z of Trading Hub th in hour h expressed in terms of \$/MWh;

$LBMPc_{zh}^{RT}$: Hourly integrated Real-Time Marginal Cost of Congestion in the load zone z of Trading Hub th in hour h expressed in terms of \$/MWh.

K.12. Day-Ahead Energy Settlements at Trading Hub Point of Withdrawal (Sink) Buses

$$\sum_{h=1}^N \{ [THE_{th}^{DA} \times (LBMPe_{zh}^{DA} + LBMP_{zh}^{DA} - LBMPc_{zh}^{DA})] \times 1 \text{ hour} \}$$

Where:

N : Number of hours in the Dispatch Day

THE_{th}^{DA} : Energy scheduled Day-Ahead to be delivered to Trading Hub th through Bilateral Transaction t , sold by the Trading Hub Energy Owner in hour h expressed in terms of MW;

$LBMPe_{zh}^{DA}$: Energy component of the Day-Ahead LBMP in the load zone z of Trading Hub th in hour h expressed in terms of \$/MWh;

$LBMP_{zh}^{DA}$: Losses component of the Day-Ahead LBMP in the load zone z of Trading Hub th in hour h expressed in terms of \$/MWh;

$LBMPc_{zh}^{DA}$: Day-Ahead Marginal Cost of Congestion in the load zone z of Trading Hub th in hour h expressed in terms of \$/MWh.

K.13. Real-Time Market Energy Settlements at Trading Hub Point of Withdrawal (Sink) Buses

$$\sum_{h=1}^N \{ [THE_{th}^{RT} - (THE_{th}^{DA} \times 1 \text{ hour})] \times (LBMPe_{zh}^{RT} + LBMP_{zh}^{RT} - LBMPc_{zh}^{RT}) \}$$

Where:

N : Number of hours in the Dispatch Day

THE_{th}^{DA} : Energy scheduled Day-Ahead to be delivered to Trading Hub th through Bilateral Transaction t , sold by the Trading Hub Energy Owner in hour h expressed in terms of MW;

THE_{th}^{RT} : Energy scheduled in the Real-Time Market to be delivered to Trading Hub th through Bilateral Transaction t , sold by the Trading Hub Energy Owner in hour h expressed in terms of megawatt hours;

$LBMPe_{zh}^{RT}$: Energy component of the hourly integrated Real-Time LBMP in the Load Zone z of Trading Hub th in hour h expressed in terms of \$/MWh;

$LBMP_{zh}^{RT}$: Losses component of the hourly integrated Real-Time LBMP in the Load Zone z of Trading Hub th in hour h expressed in terms of \$/MWh;

$LBMPe_{zh}^{RT}$: Hourly integrated Real-Time Marginal Cost of Congestion in the Load Zone z of Trading Hub th in hour h expressed in terms of \$/MWh

Appendix L. Transmission Congestion Contract (TCC) and DAM Net Congestion Rent Settlements

L.1. Congestion Rent Payments and Charges to Primary Holders of TCCs

$$\sum_{h=1}^N \left\{ \sum_{x \in X} [TCC_{hc} \times (LBMPC_{poih}^{DA} - LBMPC_{powh}^{DA})] \right\}$$

Where:

- N : Number of hours h in the Dispatch Day;
- X : Set of all Transmission Congestion Contracts x ;
- TCC_{hc} : Nominal value of TCC c in hour h , expressed in MW;
- $LBMPC_{poih}^{DA}$: Congestion component of the Day-Ahead LBMP at the Point of Injection for TCC c , in hour h , expressed in \$/MWh;
- $LBMPC_{powh}^{DA}$: Congestion component of the Day-Ahead LBMP at the Point of Withdrawal for TCC c , in hour h , expressed in \$/MWh;

L.2. Allocation of DAM Net Congestion Rent

$$\left\{ \sum_{h=1}^N \left[\left(\sum_{l \in L} LBMPRent_{lh}^{DA} + \sum_{t \in T} \{LBMPERent_{th}^{DA} + LBMPIRent_{th}^{DA} + TUCERent_{th}^{DA} + TUCIRent_{th}^{DA} + TUCWRent_{th}^{DA}\} + \sum_{g \in G} GRent_{gh}^{DA} + \sum_{v \in V} \{VLRent_{vh}^{DA} + VSRent_{vh}^{DA}\} \right) - \sum_{x \in X} TCCRent_{xh}^{DA} - \sum_{q \in Q} TCCAdj_{qh} \right] \right\} \times \left\{ \frac{OR_{qm} + ETCNL_{qm} + NARS_{qm} + GFT_{qm}}{OR_m + ETCNL_m + NARS_m + GFT_m} \right\}$$

Where:

- N : Number of hours h in the month;
- L : Set of all LSEs l ;
- T : Set of all Transmission Customers t , excluding LSEs l ;
- G : Set of all Generators g ;
- V : Set of all Virtual Load (VL) and Virtual Supply (VS) bidders v ;
- X : Set of all TCCs x ;

- Q : Set of all Transmission Owners q ;
- $LBMPRent_{lh}^{DA}$: DAM Congestion Rent paid or charged to LSE l in hour h for DAM Energy transactions, expressed in \$;
- $LBMPERent_{th}^{DA}$: DAM Congestion Rent paid or charged to Transmission Customer t in hour h for LBMP Energy Export Transactions scheduled in the DAM, expressed in \$;
- $LBMPIRent_{th}^{DA}$: DAM Congestion Rent paid or charged to Transmission Customer t in hour h for LBMP Energy Import Transactions scheduled in the DAM, expressed in \$;
- $TUCIRent_{th}^{DA}$: DAM Congestion Rent paid or charged to Transmission Customer t in hour h for Bilateral Import Transactions scheduled in the DAM, expressed in \$;
- $TUCERent_{th}^{DA}$: DAM Congestion Rent paid or charged to Transmission Customer t in hour h for Bilateral Export Transactions scheduled in the DAM, expressed in \$;
- $TUCWRent_{th}^{DA}$: DAM Congestion Rent paid or charged to Transmission Customer t in hour h for Wheel Through Transactions scheduled in the DAM, expressed in \$;
- $GRent_{gh}^{DA}$: DAM Congestion Rent paid or charged to Generator g in hour h for DAM Energy Transactions scheduled in the DAM, expressed in \$;
- $VLRent_{vh}^{DA}$: DAM Congestion Rent paid or charged to Virtual Load bidder v in hour h for Virtual Load Transactions scheduled in the DAM, expressed in \$;
- $VSRent_{vh}^{DA}$: DAM Congestion Rent paid or charged to Virtual Supply bidder v in hour h for Virtual Supply Transactions scheduled in the DAM, expressed in \$;
- $TCCRent_{xh}^{DA}$: TCC Rent paid or charged to Primary Holder of TCC x in hour h , expressed in \$;
- $TCCAdj_{qh}$: The sum of all Outage/Return-to-Service Congestion Rent Shortfall Charges, Uprate/Derate Congestion Rent Shortfall Charges, Outage/Return-to-Service Congestion Rent Surplus Payments, and Uprate/Derate Congestion Rent Surplus Payments for Transmission Owners q in hour h , expressed in \$, derived as detailed in Section 20.2.4 of Attachment N of the OATT;
- OR_{qm} : The one-month portion of the revenue for Transmission Owner q imputed to the Direct Sale or the sale in any Centralized TCC Auction sub-auction of Original Residual TCCs that are valid in month m , expressed in \$, as described in Section 20.2.5 of OATT Attachment N;
- $ETCNL_{qm}$: The sum of the one-month portion of the revenue Transmission Owner q received as payment for the Direct Sale of ETCNL or for its ETCNL released in the Centralized TCC Auction sub-auction held for TCCs valid for month m , expressed in \$, as described in Section 20.2.5 of OATT Attachment N;
- $NARS_{qm}$: The one-month portion of the Net Auction Revenues Transmission Owner q received in Centralized TCC Auction sub-auctions and Reconfiguration Auctions held for TCCs valid for month m , exclusive of any revenue from the sale of Original Residual TCCs, expressed in \$, as described in Section 20.2.5 of OATT Attachment N;
- GFT_{qm} : The one-month portion of the imputed value of Grandfathered TCCs and Grandfathered Rights, valued at their Market Clearing Prices in the Reconfiguration Auction for month m (or one-sixth of the average Market Clearing Price in stage 1 rounds in the 6-month sub-auction of the last Centralized TCC Auction if no Reconfiguration Auction was held for month m), provided that Transmission Owner

q is the selling party and the Existing Transmission Agreement related to each Grandfathered TCC and Grandfathered Right remains valid in month m , expressed in \$, as described in Section 20.2.5 of OATT Attachment N;

- OR_m : The one-month portion of the revenue for all Transmission Owners imputed to the Direct Sale or the sale in any Centralized TCC Auction sub-auction of Original Residual TCCs that are valid in month (m), expressed in \$, as described in Section 20.2.5 of OATT Attachment N;
- $ETCNL_m$: The sum of the one-month portion of the revenue that all Transmission Owners received as payment for the Direct Sale of ETCNL or for its ETCNL released in the Centralized TCC Auction sub-auction held for TCCs valid for month m , expressed in \$, as described in Section 20.2.5 of OATT Attachment N;
- $NARS_m$: The one-month portion of the Net Auction Revenues that all Transmission Owners received in Centralized TCC Auction sub-auctions and Reconfiguration Auctions held for TCCs valid for month m , exclusive of any revenue from the sale of Original Residual TCCs, expressed in \$, as described in Section 20.2.5 of OATT Attachment N;
- GFT_m : The one-month portion of the imputed value of Grandfathered TCCs and Grandfathered Rights, valued at their Market Clearing Prices in the Reconfiguration Auction for month m (or one-sixth of the average Market Clearing Price in stage 1 rounds in the 6-month sub-auction of the last Centralized TCC Auction if no Reconfiguration Auction was held for month m), for all Transmission Owners that are the selling parties and the Existing Transmission Agreement related to each Grandfathered TCC and Grandfathered Right remains valid in month m , expressed in \$, as described in Section 20.2.5 of OATT Attachment N;

Appendix M. Ancillary Services Cost Recovery and Other Charges

M.1. OATT Schedule 1 Charge – NYISO Annual Budget Charge

Annually the calculations of both physical and non-physical Rate Schedule 1 values are posted on the NYISO internet and available via this link:

<https://www.nyiso.com/billing-rates>

M.1.1. Calculation of the NYISO Annual Budget Charge for Transmission Customers Participating in Physical Market Activity

The NYISO will charge, and each Transmission Customer that participates in physical market activity will pay, a NYISO annual budget charge, on a monthly basis as calculated according to the following formula:

$$\sum_{d=1}^D \left\{ \sum_{h=1}^N [(InjUnits_{ch} \times (.28 \times ISOCosts_a \div TotalEstWd_a)) + (WdUnits_{ch} \times \{.72 \times ISOCosts_a \div TotalEstWd_a\})] \right\}$$

Where:

- D: Number of days d in the month.
- N: Number of hours h in the day.
- $ISOCosts_a$: The sum, in \$, of the NYISO's annual budgeted costs for the current calendar year.
- $InjUnits_{ch}$: The Injection Billing Units, in megawatt hours, for Transmission Customer c in hour h , except for Scheduled Energy Injections at a CTS enabled Interface with ISO New England resulting from Imports that are not associated with wheels through New England. For an Energy Storage Resource, or a DER Aggregation the injection billing unit will be the sum of the injection MWh plus the absolute value of the withdrawal MWh. In addition, Demand Reduction by a DER Aggregation shall be included as Injection Billing Units.
- $WdUnits_{ch}$: The Withdrawal Billing Units, in megawatt hours, for Transmission Customer c in hour h , except for Scheduled Energy Withdrawals at a CTS Enabled Interface with ISO New England resulting from Exports that are not associated with wheels through New England

TotalEstWd_a: The sum, in megawatt hours, of estimated Withdrawal Billing Units for all Transmission Customers in the current calendar year as determined by the NYISO in the summer prior to the current calendar year except for Scheduled Energy Withdrawals at a CTS Enabled Interface with ISO New England resulting from Exports that are not associated with wheels through New England.

The current 72%/28% cost allocation methodology between Withdrawal Billing Units and Injection Billing Units for the NYISO annual budget charge will remain unchanged through at least December 31, 2016, and will continue to remain unchanged until such point in time that a study is conducted and the results of the study warrant changing the 72%/28% cost allocation. The methodology for the review and modification of the NYISO annual budget charge and cost allocation is detailed in Section 6.1.2.3 of Schedule 1 of the *NYISO OATT*.

M.1.2. Calculation of the NYISO Annual Budget Charge for Transmission Customers Engaging in Virtual Transactions

The NYISO will charge, and each Transmission Customer that has its virtual Bids accepted and thereby engages in Virtual Transactions will pay, a charge for such activity on a monthly basis as calculated according to the following formula:

$$VTRate \times VTCleared_{cM}$$

Where:

VTRate: For calendar year 2012, the applicable rate will be \$0.0871 per cleared megawatt hour of Virtual Transactions, based on a \$2.6 million projected 2012 annual revenue requirement. For calendar years following 2012, the applicable rate will be calculated in accordance with the formula set forth in Section 6.1.2.4.4 of Schedule 1 of the *NYISO OATT*.

VTCleared_{cM}: The total cleared Virtual Transactions, in megawatt hours, for Transmission Customer *c* in month *M*.

The charge will appear in a manual adjustment applied to the initial month of the monthly invoice with the charge for Transmission Customers aggregated to the Billing Org level.

M.1.3. Calculation of the NYISO Annual Budget Charge for Transmission Customers Purchasing Transmission Congestion Contracts

The NYISO will charge, and each Transmission Customer that purchases Transmission Congestion Contracts — excluding Transmission Congestion Contracts that are created prior to January 1, 2010 — will

pay, a charge for such activity on a monthly basis as calculated according to the following formula:

$$TCCRate \times TCCSettled_{cM}$$

Where:

- TCCRate:** For calendar year 2012, the applicable rate will be \$0.0372 per settled megawatt hour of Transmission Congestion Contracts, based on a \$4.9 million projected 2012 annual revenue requirement. For calendar years following 2012, the applicable rate will be calculated in accordance with the formula set forth in Section 6.1.2.4.4 of Schedule 1 of the *NYISO OATT*.
- TCCSettled_{cM}:** The total settled Transmission Congestion Contracts, excluding Transmission Congestion Contracts created prior to January 1, 2010, in megawatt hours, for Transmission Customer *c* in Month *M*.

The charge will appear in a manual adjustment applied to the initial month of the monthly invoice with the charge for Transmission Customers aggregated to the Billing Org level.

M.1.4. Calculation of the NYISO Annual Budget Charge for Transmission Customers Participating in the Special Case Resource Program or Emergency Demand Response Program

The NYISO will charge, and each Transmission Customer that participates in the NYISO's Special Case Resource program or its Emergency Demand Response program will pay, a charge for such activity on a monthly basis as calculated according to the following formula:

$$DRInj_{cM} \times (.28 \times ISOCosts_a \div TotEstWd_a)$$

Where:

- DRInj_{cM}:** The total Load reduction, in megawatt hours, measured and compensated during testing or an actual event for Transmission Customer *c* in month *M*.
- ISOCosts_a:** The sum, in \$, of the NYISO's annual budgeted costs in the current calendar year.
- TotEstWd_a:** The sum, in megawatt hours, of estimated Withdrawal Billing Units for all Transmission Customers in the current calendar year as determined by the NYISO in the summer prior to the current calendar year, except for Scheduled Energy Withdrawals at a CTS Enabled Interface with ISO New England resulting from Exports that are not associated with wheels through New England.

The charge will appear in a manual adjustment applied to the initial month of the monthly invoice with the charge for Transmission Customers aggregated to the Billing Org level.

M.1.5. Calculation of the Credit for Transmission Customers Participating in Physical Market Activity After Recovery of NYISO Annual Budgeted Costs for the Preceding Year

The NYISO will use the revenue collected from the NYISO annual budget charges to Transmission Customers for non-physical market activity, the Special Case Resource program and the Emergency Demand Response program, as calculated above, to fully recover any of its annual budgeted costs for the immediately preceding calendar year that it has not already recovered. Once it has fully recovered its annual budgeted costs for the immediately preceding calendar year, the NYISO will distribute, on a monthly basis for the remainder of the calendar year, any additional revenue collected from the NYSIO annual budget charges to Transmission Customers for non-physical market activity, the Special Case Resource program, and the Emergency Demand Response program, as calculated above, to each Transmission Customer participating in physical market activity, in accordance with the following formula.

$$\begin{aligned} & [NonPhyRev_M \times (.28 \times InjUnits_{c,M} \div TotalInj_M)] \\ & + [NonPhyRev_M \times (.72 \times WdUnits_{c,M} \div TotalWd_M)] \end{aligned}$$

Where:

- NonPhyRev_M:** This amount will be \$0 for each month *M* until the NYISO fully recovers, through the charges to Transmission Customers for non-physical market activity, the Special Case Resource program, and the Emergency Demand Response program, as calculated above, any of its annual budgeted costs for the immediately preceding calendar year that it has not already recovered from Transmission Customers based on their physical market activities for that year. For each month *M* thereafter for the remainder of the calendar year, this amount shall be the sum, in \$, of the revenue collected by the NYISO for month *M* through the charges to Transmission Customers for non-physical market activity, the Special Cases Resource program, and the Emergency Demand Response program as calculated above.
- InjUnits_{cM}:** The Injection Billing Units, in megawatt hours, for Transmission Customer *c* in month *M*, except for Scheduled Energy Injections at a CTS Enabled Interface with ISO NE England resulting from Imports that are not associated with wheels through New England. For an Energy Storage Resource, or DER Aggregation, the injection billing unit will be the sum of the injection MWh plus the absolute value of the withdrawal MWh. In addition, Demand Reduction by a DER Aggregation shall be included as Injection Billing Units.
- WdUnits_{cM}:** The Withdrawal Billing Units, in megawatt hours, for Transmission Customer *c* in month *M*, except for Scheduled Energy Withdrawals at a CTS Enabled Interface with ISO New England resulting from Exports that are not associated with wheels through New England.
- TotalInj_M:** The sum, in megawatt hours, of Injection Billing Units for all Transmission Customers in month *M*, except for Scheduled Energy Injections at a CTS Enabled Interface with ISO New England resulting from Imports that are not associated with wheels through New England.

TotalWd_M: The sum, in megawatt hours, of Withdrawal Billing Units for all Transmission Customers in month *M*, except for Scheduled Energy Withdrawals at a CTS Enabled Interface with ISO New England resulting from Exports that are not associated with wheels through New England.

The credit will appear in a manual adjustment applied to the monthly invoice with the charge for Transmission Customers aggregated to the Billing Org level.

M.2. OATT Schedule 1 Charge - NERC and NPCC Charges

The NYISO will charge, and each Transmission Customer will pay, a charge on a quarterly basis to recover the NERC and NPCC costs invoiced to the NYISO by NERC and NPCC for the upcoming calendar quarter as calculated according to the following formula:

$$NERC/NPCCCosts_Q \times (TUWdUnits_{cM} \div TotalWd_M)$$

Where:

M: The month in which the NYISO charges Transmission Customers to recover NERC and NPCC costs for calendar quarter *Q*.

NERC/NPCCCosts_Q: The NERC and NPCC costs, in \$, invoiced to the NYISO for calendar quarter *Q*.

TUWdUnits_{cM}: The Withdrawal Billing Units, in megawatt hours, for Transmission Customer *c* in its four-month true-up invoice that is issued with its regular monthly invoice in month *M*, except for Withdrawal Billing Units for Wheels Through and Exports.

TotalWd_M: The sum, in megawatt hours, of Withdrawal Billing Units for all Transmission Customers in their four-month true-up invoices that are issued with their regular monthly invoices in month *M*, except for Withdrawal Billing Units for Wheels Through and Exports.

In calculating the Withdrawal Billing Units for this NERC and NPCC charge, the NYISO will use the LSE bus meter data that have been submitted by the Meter Authorities for use in the calculation of the four-month true-up of the Transmission Customer's monthly invoice pursuant to Sections 3.3 of this Manual. This calculation of the NERC and NPCC charge will not be subject to correction or adjustment.

The charge will appear in a manual adjustment with the charge for Transmission Customers aggregated to the Billing Org level.

M.3. OATT Schedule 1 Charge – Non-NYISO Facilities Payment Charge

M.3.1. Calculation of the Non-NYISO Facilities Payment Charge for Transmission Customers Based on Withdrawal Billing Units Not Used to Supply Station Power under Part 5 of the NYISO OATT

The NYISO will charge, and each Transmission Customer will pay based on its Withdrawal Billing Units that are not used to supply Station Power as a third-party provider, a non-NYISO facilities charge for each month, as calculated according to the following formula:

$$\sum_{d=1}^D \left\{ \sum_{h=1}^H ((\text{NonNYISOFacCst}_M \div N) \times (\text{WdUnits}_{ch} \div \text{TotalWd}_h)) \right\}$$

Where:

D: Number of days *d* in the month.

H: Number of hours *h* in the day.

N: Total number of hours *h* in Month *M*.

NonNYISOFacCst_M: The sum, in \$, of the NYISO’s bills for month *M* for the non-NYISO facilities from (i) Consolidated Edison Co. of New York (less the one-half of such bill paid by PJM Interconnection, LLC) and (ii) Rochester Gas and Electric Corporation.

WdUnits_{ch}: The Withdrawal Billing Units, in megawatt hours, for Transmission Customer *c* in hour *h*, except for the Withdrawal Billing Units to supply Station Power as a third-party provider and except for Scheduled Energy Withdrawals at a CTS Enabled Interface with ISO New England resulting from Exports that are not associated with wheels through New England.

TotalWd_h: The sum, in megawatt hours, of Withdrawal Billing Units for all Transmission Customers in hour *h*, except for the Withdrawal Billing Units to supply Station Power as third-party providers and except for Scheduled Energy Withdrawals at a CTS Enabled Interface with ISO New England resulting from Exports that are not associated with wheels through New England.

M.3.2. Calculation of the Non-NYISO Facilities Payment Charge for Transmission Customers Based on Withdrawal Billing Units to Supply Station Power under Part 5 of the NYISO OATT

The NYISO will charge, and each Transmission Customer will pay based on its Withdrawal Billing Units used to supply Station Power as a third-party provider, a non-NYISO facilities charge for each month as calculated according to the following formula:

$$\sum_{d=1}^N \{ (\text{NonNYISOFacCst}_M \div N) \times (\text{SP}_{cd} \div \text{TotalWd}_d) \}$$

Where:

N: Number of days d in month M .

SP_{cd} : The Withdrawal Billing Units, in megawatt hours, of Transmission Customer c used to supply Station Power as a third-party provider for day d .

$NonNYISOFacCst_M$: The sum, in \$, of the NYISO's bills for month M for the non-NYISO facilities from (i) Consolidated Edison Co. of New York and (ii) Rochester Gas and Electric Corporation.

$TotalWd_d$: The sum, in megawatt hours, of Withdrawal Billing Units for all Transmission Customers in day d , except for the Withdrawal Billing Units to supply Station Power as third-party providers and except for Scheduled Energy Withdrawals at a CTS Enabled Interface with ISO New England resulting from Exports that are not associated with wheels through New England.

M.4. Calculation of the Non-NYISO Facilities Payment Credit

The NYISO will credit each Transmission Customer based on its Withdrawal Billing Units that are not used to supply Station Power as a third-party provider, an amount of the revenue collected through the non-NYISO facilities payment charge recovered from third-party Station Power providers for each month. This credit will be calculated according to the following formula:

$$\sum_{d=1}^D \{NonNYISOFacCh_d \times (WdUnits_{cd} \div TotalWd_d)\}$$

Where:

D: Number of days d in month M .

$NonNYISOFacCh_d$: The sum of non-NYISO facilities payment charges, in \$, for all Transmission Customers that supply Station Power as third-party providers for day d .

$WdUnits_{cd}$: The Withdrawal Billing Units, in megawatt hours, for Transmission Customer c in day d , except for the Withdrawal Billing Units to supply Station Power as a third-party provider and except for Scheduled Energy Withdrawals at a CTS Enabled Interface with ISO New England resulting from Exports that are not associated with wheels through New England.

$TotalWd_d$: The sum, in megawatt hours, of Withdrawal Billing Units for all Transmission Customers in day d , except for the Withdrawal Billing Units to supply Station Power as third-party providers and except for Scheduled Energy Withdrawals at a CTS Enabled Interface with ISO New England resulting from Exports that are not associated with wheels through New England.

M.5. OATT Schedule 1 Charge – Local Reliability Rules G.2 and G.3

The NYISO will charge, and each Transmission Customer will pay based on its Withdrawal Billing Units that are not used to supply Station Power as a third-party provider, a charge for the recovery of the costs of payments to Suppliers pursuant to the incremental cost recovery for units that responded to either (i) Local Reliability Rule G.2 or (ii) Local Reliability Rule G.3, as applicable, for each month. This charge will be equal to the sum of the daily charges for the Transmission Customer, as calculated according to the following formula, for each day in the relevant month. The NYISO will perform this calculation separately to recover as applicable either (i) the payment costs related to Local Reliability G.2, or (ii) the payment costs related to Local Reliability Rule G.3.

$$\sum_{d=1}^D \{LRRPay_d \times (TDWd_{cd} \div TDTotalWd_d)\}$$

Where:

- D: Number of days d in the relevant month.
- LRRPay $_d$: The amount, in \$, paid in day d to Suppliers pursuant to the incremental cost recovery for units that responded, as applicable, to either (i) Local Reliability Rule G.2 in the Consolidated Edison Transmission District or (ii) Local Reliability Rule G.3 in the LIPA Transmission District.
- TDWd $_{cd}$: The Withdrawal Billing Units, in megawatt hours, for Transmission Customer c in day d in either (i) the Consolidated Edison Transmission District (in the case of Local Reliability Rule G.2) or (ii) the LIPA Transmission District (in the case of Local Reliability Rule G.3), except for the Withdrawal Billing Units to supply Station Power as a third-party provider.
- TDTotalWd $_d$: The sum, in megawatt hours, of Withdrawal Billing Units for all Transmission Customers in day d in either (i) the Consolidated Edison Transmission District (in the case of Local Reliability Rule G.2) or (ii) the LIPA Transmission District (in the case of Local Reliability Rule G.3), except for the Withdrawal Billing Units to supply Station Power as third-party providers.

M.6. OATT Schedule 1 Charge – Residual Costs Payment \ Charge

M.6.1. Calculation of the Residual Costs Payment/Charge for Transmission Customers Based on Withdrawal Billing Units Not Used to Supply Station Power under Part 5 of the NYISO OATT

The NYISO will calculate, and each Transmission Customer will receive or pay based on its Withdrawal Billing Units that are not used to supply Station Power as a third-party provider, a residual costs payment or a residual costs charge for each month according to the formula below. If the result of the calculation below is positive, the NYISO will pay the Transmission Customer a residual costs payment for the relevant month. If the result of the calculation below is negative, the NYISO will charge the Transmission Customer a

residual costs charge for the relevant month.

$$\sum_{d=1}^D \left\{ \sum_{h=1}^H ((CustPmts_h - ISOPmts_h) \times (WdUnits_{ch} \div TotalWd_h)) \right\}$$

Where:

H: the number of hours h in a day.

D: the number of days d in the relevant month.

$WdUnits_{ch}$: The Withdrawal Billing Units, in megawatt hours, for Transmission Customer c in hour h , except for the Withdrawal Billing Units to supply Station Power as a third-party provider and except for Scheduled Energy Withdrawals at a CTS Enabled Interface with ISO New England resulting from Exports that are not associated with wheels through New England.

$TotalWd_h$: The sum, in megawatt hours, of Withdrawal Billing Units for all Transmission Customers in hour h , except for the Withdrawal Billing Units to supply Station Power as third-party providers and except for Scheduled Energy Withdrawals at a CTS Enabled Interface with ISO New England resulting from Exports that are not associated with wheels through New England.

$CustPmts_h$: The NYISO's receipts, in \$, for each hour h from Transmission Customers that equal the sum of the following components, which could be either positive or negative amounts:

Payments of the Energy component and Marginal Losses component of LBMP for Energy scheduled in the LBMP Market in hour h in the Day-Ahead Market;

Payments of the Energy component, Marginal Losses component, and Congestion component of LBMP for Energy purchased in the Real-Time LBMP Market for hour h that was not scheduled Day-Ahead;

Payments of the Energy component, Marginal Losses component, and Congestion component of LBMP for Energy by Suppliers that provided less Energy in the real-time dispatch for hour h than they were scheduled Day-Ahead to provide in hour h for the LBMP Market;

The Marginal Losses Component of the TUC payments made in accordance with the *NYISO OATT* for Bilateral Transactions that were scheduled in hour h in the Day-Ahead Market;

The Marginal Losses Component and Congestion Component of the real-time TUC payments made in accordance with the *NYISO OATT* for Bilateral Transactions that were not scheduled in hour h in the Day-Ahead Market; and

The M2M settlement between the NYISO and PJM Interconnection, L.L.C. for hour h determined in accordance with Section 8 of Schedule D to Attachment CC of the *NYISO OATT*.

$ISOPmts_h$: The NYISO's payments, in \$, in each hour h to Suppliers that equal the sum of the following components, which could be either positive or negative amounts;

Payments of the Energy component and Marginal Losses component of LBMP for Energy to Suppliers that were scheduled to provide in the LBMP Market in hour h in the Day-Ahead Market;

Payments to Suppliers of the Energy component, Marginal Losses component, and Congestion component of LBMP for Energy provided to the NYISO in the Real-Time Dispatch for hour h that those Suppliers were not scheduled to provide Energy in hour h in the Day-Ahead Market;

Payments of the Energy component and Marginal Losses component of LBMP for Energy to LSEs that consumed less Energy in the real-time dispatch than those LSEs were scheduled Day-Ahead to consume in hour h ; and

Payments of the Marginal Losses component and Congestion component of the real-time TUC to Transmission Customers that reduced their Bilateral Transaction schedules for hour h after the Day-Ahead Market.

M.6.2. Calculation of the Residual Costs Payment/Charge for Transmission Customers Based on Withdrawal Billing Units to Supply Station Power under Part 5 of the NYISO OATT

The NYISO will calculate, and each Transmission Customer will receive or pay based on its Withdrawal Billing Units used to supply Station Power as a third-party provider, a residual costs payment or a residual costs charge for each month according to the formula below. If the result of the calculation below is positive, the NYISO will pay the Transmission Customer a residual costs payment for the relevant month. If the result of the calculation below is negative, the NYISO will charge the Transmission Customer a residual costs charge for the relevant month.

$$\sum_{d=1}^D \{[(CustPmts_d - ISOPmts_d) \div TotalWd_d] \times SP_{cd}\}$$

Where:

D: Number of days d in month M .

SP_{cd} : The Withdrawal Billing Units, in megawatt hours, of Transmission Customer c used to supply Station Power as a third-party provider for day d .

$CustPmts_d$: The NYISO's receipts, in \$, for each day d from Transmission Customers, which could be either positive or negative amounts, for the sum of the Transmission Customer payment components described above.

- ISOPmts_d:** The NYISO’s payments, in \$, for each day *d* to Suppliers, which could be either positive or negative amounts, for the sum of the NYISO payment components described above.
- TotalWd_h:** The sum, in megawatt hours, of Withdrawal Billing Units for all Transmission Customers in day *d*, except for the Withdrawal Billing Units to supply Station Power as third-party providers and except for Scheduled Energy Withdrawals at a CTS Enabled Interface with ISO New England resulting from Exports that are not associated with wheels through New England.

M.6.3. Calculation of the Residual Costs Adjustment

The NYISO will calculate, and each Transmission Customer will receive or pay based on its Withdrawal Billing Units that are not used to supply Station Power as a third-party provider, a residual costs adjustment for each month, according to the following formula. If the amount of the below calculation is positive for the month, the NYISO will pay the Transmission Customer the adjustment amount. If the amount of the below calculation is negative for the month, the NYISO will charge the Transmission Customer the adjustment amount.

$$\sum_{d=1}^N \{ResidCosts_d \times (WdUnits_{cd} \div TotalWd_d)\}$$

Where:

- N:** Number of days *d* in month *M*.
- ResidCost_d:** (i) If Transmission Customers were responsible for a residual costs charge for day *d* from third-party Station Power providers, the (positive) amount, in \$, of the costs that the NYISO has collected through the residual costs charges for all Transmission Customers for day *d*. (ii) If Transmission Customers received a residual costs payment for day *d* from third-party Station Power providers, the (negative) amount, in \$, of the revenue that the NYISO has paid through the residual costs payments to all Transmission Customers for day *d*.
- WdUnits_{cd}:** The Withdrawal Billing Units, in megawatt hours, for Transmission Customer *c* in day *d*, except for the Withdrawal Billing Units to supply Station Power as a third-party provider and except for Scheduled Energy Withdrawals at a CTS Enabled Interface with ISO New England resulting from Exports that are not associated with wheels through New England.
- TotalWd_d:** The sum, in megawatt hours, of Withdrawal Billing Units for all Transmission Customers in day *d*, except for the Withdrawal Billing Units to supply Station Power as third-party providers and except for Scheduled Energy Withdrawals at a CTS Enabled

Interface with ISO New England resulting from Exports that are not associated with wheels through New England..

M.7. Storm Watch Redispatch Costs and Allocation

M.7.1. Calculation of Storm Watch Redispatch Cost

$SWCA_h$, the total amount of Storm Watch cost, that will be reallocated for hour h when Storm Watch is declared for one or more RTD intervals in that hour, is calculated as follows:

$$SWCA_h = \sum_{i=1}^{N_h} \left\{ \sum_{\forall c \in C} \max(Flow_{ch}^{DA} - Flow_{ci}^{RT}, 0) \times SP_{ci}^{RT} \times s_i^{RT} \div 3600 \right\}$$

Where:

- N_h : Number of RTD intervals in hour h ;
- C : Set of constraints c affected by Storm Watch contingencies;
- $Flow_{ch}^{DA}$: The scheduled DAM flow across constraint c in hour h , which contains RTD interval i , expressed in MW;
- $Flow_{ci}^{RT}$: The scheduled real-time flow across constraint c in RTD interval i , expressed in MW;
- SP_{ci}^{RT} : Absolute value of the Real-time shadow price of Storm Watch constraint c in RTD interval i , expressed in \$/MW;
- s_i^{RT} : Length of RTD interval i , expressed in seconds;

M.7.2. Allocation of Storm Watch Redispatch Costs to Zone J Withdrawals

SWC_{cd} , the total amount of Storm Watch cost that will be allocated to customer c for day d when Storm Watch is declared for one or more RTD intervals in that day, is calculated as follows:

$$SWC_{cd} = \left\{ \sum_{h=1}^{N_d} SWCA_h \times \left[\frac{SZWdUnits_{ch}}{SZTotalWd_h} \right] \right\}$$

Where:

- N_d : Number of hours h in day d ; $SWCA_h$: Storm Watch cost to be allocated for hour h , expressed in \$;
- $SZWdUnits_{ch}$: The Withdrawal Billing Units, in megawatt hours, for Transmission Customer c in hour h in Load Zone J, including Withdrawal Billing Units to supply Station Power as a third-party provider.
- $SZTotalWd_h$: The sum, in megawatt hours, of Withdrawal Billing Units for all Transmission Customers in hour h in Load Zone J, including Withdrawal Billing Units to supply Station Power as third-party providers.

M.7.3. Allocation of Storm Watch Redispatch Costs Rebate to NYISO Wide Withdrawals

SWR_{cd} , the total amount of Storm Watch cost that will be rebated to customer c for day d when Storm Watch is declared for one or more RTD intervals in that day, is calculated as follows:

$$SWR_{cd} = \left\{ \sum_{h=1}^{N_d} SWCA_h \times \left[\frac{WdUnits_{ch}}{TotalWd_h} \right] \right\}$$

N_d : Number of hours h in day d ;

$SWCA_h$: Storm Watch cost to be allocated for hour h , expressed in \$;

$WdUnits_{ch}$: The Withdrawal Billing Units, in megawatt hours, for Transmission Customer c in hour h , including the Withdrawal Billing Units to supply Station Power as a third-party provider and except for Scheduled Energy Withdrawals at a CTS Enabled Interface with ISO New England resulting from Exports that are not associated with wheels through New England;

$TotalWd_h$: The sum, in megawatt hours, of Withdrawal Billing Units for all Transmission Customers in hour h , including the Withdrawal Billing Units to supply Station Power as third-party providers and except for Scheduled Energy Withdrawals at a CTS Enabled Interface with ISO New England resulting from Exports that are not associated with wheels through New England.

M.8. OATT Schedule 1 Charge – Special Case Resources and Curtailment Service Providers

M.8.1. Calculation of a Charge for the Recovery of Costs for Payments for Special Case Resources and Curtailment Service Providers Called to Meet the Reliability Needs of a Local System

The NYISO will recover the costs of payments to Special Case Resources (SCRs) and Curtailment Service Providers (CSPs) that were called to meet the reliability needs of a local system. To do so, the NYISO will charge, and each Transmission Customer that serves Load in the Subzone for which the reliability services of the SCRs and CSPs were called will pay based on its Withdrawal Billing Units that are not used to supply Station Power as a third-party provider, a charge in accordance with the following formula for each Subzone:

$$\sum_{d=1}^D \left\{ \sum_{h=1}^H (LocalCosts_h \times (SZWdUnits_{ch} \div SZTotalWd_h)) \right\}$$

Where:

H: The number of hours h in day d .

D: The number of days d in month M .

- LocalCosts_h*: The payments, in \$, for hour *h* in the relevant Subzone made to Suppliers for SCRs and CSPs called to meet the reliability needs of that Subzone.
- SZWdUnits_{ch}*: The Withdrawal Billing Units, in megawatt hours, for Transmission Customer *c* in hour *h* in the relevant Subzone, except for Withdrawal Billing Units for Wheels Through, Exports, and to supply Station Power as a third-party provider.
- SZTotalWd_h*: The sum, in megawatt hours, of Withdrawal Billing Units for all Transmission Customers in hour *h* in the relevant Subzone, except for Withdrawal Billing Units for Wheels Through, Exports, and to supply Station Power as third-party providers.

M.8.2. Calculation of a Charge for the Recovery of Costs for Payments for Special Case Resources and Curtailment Service Providers Called to Meet the Reliability Needs of the NYCA

The NYISO will recover the costs of payments to SCRs and CSPs that were called to meet the reliability needs of the NYCA. To do so, the NYISO will charge, and each Transmission Customer that serves Load in the New York Control Area (NYCA) will pay based on its Withdrawal Billing Units except for the Withdrawal Billing Units for Wheels Through, Exports, or to supply Station Power as a third-party provider, a charge in accordance with the following formula:

$$\sum_{d=1}^D \left\{ \sum_{h=1}^H (NYCACosts_h \times (WdUnits_{ch} \div TotalWd_h)) \right\}$$

Where:

- H*: The number of hours *h* in day *d*.
- D*: The number of days *d* in month *M*.
- NYCACosts_h*: The payments, in \$, for hour *h* made to Suppliers for SCRs and CSPs called to meet the reliability needs of the NYCA.
- WdUnits_{ch}*: The Withdrawal Billing Units, in megawatt hours, for Transmission Customer *c* in hour *h*, except for Withdrawal Billing Units for Wheels Through, Exports, or to supply Station Power as a third-party provider.
- TotalWd_h*: The sum, in megawatt hours, of Withdrawal Billing Units for all Transmission Customers in hour *h*, except for Withdrawal Billing Units for Wheels Through, Exports, or to supply Station Power as third-party providers.

M.9. OATT Rate Schedule 1 Charge – Local Reliability Day-Ahead Margin Assurance Payments Charge

M.9.1. Calculation of the Local Reliability Day-Ahead Margin Assurance Payment (DAMAP) Charge for Transmission Customers Based on Withdrawal Billing Units Not Used to Supply Station Power under Part 5 of the NYISO OATT

The NYISO will charge, and each Transmission Customer that serves Load in the Subzone where the

Resource is located will pay based on its Withdrawal Billing Units that are not used to supply Station Power as a third-party provider, a charge in accordance with the following formula for each Subzone:

$$\sum_{d=1}^D \left\{ \sum_{h=1}^H (DAMAPCosts_h \times (SZWdUnits_{ch} \div SZTotalWd_h)) \right\}$$

Where:

D: Number of days d in month M ,

H: Number of hours h in day d ,

$DAMAPCosts_h$: The DAMAP costs, in \$, for hour h in the relevant Subzone incurred to compensate Resources meeting the reliability needs of that Subzone.

$SZWdUnits_{ch}$: The Withdrawal Billing Units, in megawatt hours, for Transmission Customer c in hour h in the relevant Subzone, except for Withdrawal Billing Units for Wheels Through, Exports, and to supply Station Power as a third-party provider.

$SZTotalWd_h$: The sum, in megawatt hours, of Withdrawal Billing Units for all Transmission Customers in hour h in the relevant Subzone, except for Withdrawal Billing Units for Wheels Through, Exports, and to supply Station Power as third-party providers.

M.9.2. Calculation of the Local Reliability DAMAP Charge for Transmission Customers Based on Withdrawal Billing Units to Supply Station Power under Part 5 of the NYISO OATT

The NYISO will charge, and each Transmission Customer that serves Load in the Subzone where the Resource is located will pay based on its Withdrawal Billing Units used to supply Station Power as a third-party provider, a charge in accordance with the following formula for each Subzone:

$$\sum_{d=1}^N \{ (DAMAPCosts_d \div SZTotalWd_h) \times SZSP_{cd} \}$$

Where:

N: Number of days d in month M .

$SZSP_{cd}$: The Withdrawal Billing Units, in megawatt hours, of Transmission Customer c in day d in the relevant Subzone that are used to supply Station Power as a third-party provider, except for Withdrawal Billing Units for Wheels Through and Exports.

$DAMAPCosts_d$: The DAMAP costs, in \$, for day d in the relevant Subzone incurred to compensate Resources meeting the reliability needs of that Subzone.

$SZTotalWd_h$: The sum, in megawatt hours, of Withdrawal Billing Units for all Transmission Customers in day d in the relevant Subzone, except for Withdrawal Billing Units for Wheels Through, Exports, and to supply Station Power as third-party providers.

M.9.3. Calculation of the Local Reliability DAMAP Credit

The NYISO will calculate, and each Transmission Customer that serves Load in the Subzone where the Resource is located will receive based on its Withdrawal Billing Units that are not used to supply Station Power as a third-party provider, an amount of the revenue collected through the Local Reliability DAMAP charge recovered from third-party Station Power providers. This credit will be calculated according to the following formula:

$$\sum_{d=1}^N \{LRRDAMAPCh_d \times (SZWdUnits_{ch} \div SZTotalWd_h)\}$$

Where:

N: Number of days d in month M .

$LRRDAMAPCh_d$: The sum of Local Reliability DAMAP charges, in \$, for all Transmission Customers supplying Station Power as third-party providers in the relevant Subzone as calculated above for day d .

$SZWdUnits_{ch}$: The Withdrawal Billing Units, in megawatt hours, for Transmission Customer c in day d in the relevant Subzone, except for Withdrawal Billing Units for Wheels Through, Exports, and to supply Station Power as a third-party provider.

$SZTotalWd_h$: The sum, in megawatt hours, of Withdrawal Billing Units for all Transmission Customers in day d in the relevant Subzone, except for Withdrawal Billing Units for Wheels Through, Exports, and to supply Station Power as third-party providers.

M.10. OATT Rate Schedule 1 Charge – NYCA Reliability DAMAP Charge

M.10.1. Calculation of the NYCA Reliability DAMAP Charge for Transmission Customers Based on Withdrawal Billing Units Not Used to Supply Station Power under Part 5 of the NYISO OATT

The NYISO will charge, and each Transmission Customer will pay based on its Withdrawal Billing Units that are not used to supply Station Power as a third-party provider, a charge in accordance with the following formula:

$$\sum_{d=1}^D \left\{ \sum_{h=1}^H (NYCADAMAPCosts_h \times (WdUnits_{ch} \div TotalWd_h)) \right\}$$

Where:

D: Number of days d in month M ,

H: Number of hours h in day d ,

$NYCADAMAPCosts_h$: The DAMAP costs, in \$, for hour h incurred to compensate Resources meeting the reliability needs of the NYCA.

$WdUnits_{ch}$: The Withdrawal Billing Units, in megawatt hours, for Transmission Customer c in hour h , except for Withdrawal Billing Units to supply Station Power as a third-party provider and except for Scheduled Energy Withdrawals at a CTS Enabled Interface with ISO New England resulting from Exports that are not associated with wheels through New England.

$TotalWd_h$: The sum, in megawatt hours, of Withdrawal Billing Units for all Transmission Customers in hour h , except for Withdrawal Billing Units to supply Station Power as third-party providers and except for Scheduled Energy Withdrawals at a CTS Enabled Interface with ISO New England resulting from Exports that are not associated with wheels through New England.

M.10.2. Calculation of the NYCA Reliability DAMAP Charge for Transmission Customers Based on Withdrawal Billing Units to Supply Station Power under Part 5 of the NYISO OATT

The NYISO will charge, and each Transmission Customer will pay based on its Withdrawal Billing Units used to supply Station Power as a third-party provider, a charge in accordance with the following formula:

$$\sum_{d=1}^N \{(NYCADAMAPCosts_d \div TotalWd_d) \times SP_{cd}\}$$

Where:

N : Number of days d in month M .

SP_{cd} : The Withdrawal Billing Units, in megawatt hours, of Transmission Customer c in day d that are used to supply Station Power as a third-party provider.

$NYCADAMAPCosts_d$: The DAMAP costs, in \$, for day d incurred to compensate Resources meeting the reliability needs of the NYCA.

$TotalWd_d$: The sum, in megawatt hours, of Withdrawal Billing Units for all Transmission Customers in day d , except for Withdrawal Billing Units to supply Station Power as third-party providers and except for Scheduled Energy Withdrawals at a CTS Enabled Interface with ISO New England resulting from Exports that are not associated with wheels through New England.

M.10.3. Calculation of the NYCA Reliability DAMAP Credit

The NYISO will calculate, and each Transmission Customer will receive based on its Withdrawal Billing Units that are not used to supply Station Power as a third-party provider, an amount of the revenue collected through the NYCA Reliability DAMAP charge recovered from third-party Station Power providers. This credit will be calculated according to the following formula:

$$\sum_{d=1}^N \{NYCADAMAPCh_d \times (WdUnits_{cd} \div TotalWd_d)\}$$

Where:

- N:** Number of days d in month M .
- $NYCADAMAPCh_d$:** The sum of NYCA Reliability DAMAP charges, in \$, for all Transmission Customers supplying station power as third-party providers as calculated above for day d .
- $WdUnits_{cd}$:** The Withdrawal Billing Units, in megawatt hours, for Transmission Customer c in day d , except for Withdrawal Billing Units to supply Station Power as a third-party provider and except for Scheduled Energy Withdrawals at a CTS Enabled Interface with ISO New England resulting from Exports that are not associated with wheels through New England.
- $TotalWd_d$:** The sum, in megawatt hours, of Withdrawal Billing Units for all Transmission Customers in day d , except for the Withdrawal Billing Units to supply Station Power as third-party providers and except for Scheduled Energy Withdrawals at a CTS Enabled Interface with ISO New England resulting from Exports that are not associated with wheels through New England.

M.11. OATT Schedule 1 Charge – Import Curtailment Guarantee Payment Charge

M.11.1. Calculation of the Import Curtailment Guarantee Payment Charge for Transmission Customers Based on Withdrawal Billing Units Not Used to Supply Station Power under Part 5 of the NYISO OATT

The NYISO will charge, and each Transmission Customer will pay based on its Withdrawal Billing Units that are not used to supply Station Power as a third-party provider, a monthly charge to recover the costs of all Import Curtailment Guarantee Payments paid to Import Suppliers for each month. This monthly charge will be calculated in accordance with the following formula:

$$\sum_{d=1}^D \left\{ \sum_{h=1}^H (ICGC_h \times (WdUnits_{ch} \div TotalWd_d)) \right\}$$

Where:

- D:** Number of days d in the month,
- H:** Number of hours h in the day,
- $ICGC_h$:** The costs, in \$, for the Import Guarantee payments to Import Suppliers for hour h .
- $WdUnits_{ch}$:** The Withdrawal Billing Units, in megawatt hours, for Transmission Customer c in hour h , except for Withdrawal Billing Units to supply Station Power as a third-party provider and except for Scheduled Energy Withdrawals at a CTS Enabled Interface

with ISO New England resulting from Exports that are not associated with wheels through New England.

TotalW_d: The sum, in megawatt hours, of Withdrawal Billing Units for all Transmission Customers in hour *h*, except for Withdrawal Billing Units to supply Station Power as third-party providers and except for Scheduled Energy Withdrawals at a CTS Enabled Interface with ISO New England resulting from Exports that are not associated with wheels through New England.

M.11.2. Calculation of the Import Supplier Guarantee Payment Charge for Transmission Customers Based on Withdrawal Billing Units to Supply Station Power under Part 5 of the NYISO OATT

The NYISO will charge, and each Transmission Customer will pay based on its Withdrawal Billing Units used to supply Station Power as a third-party provider, a monthly charge to recover the costs of all Import Supplier Guarantee Payments paid to Import Suppliers for each month. This charge will be calculated in accordance with the following formula:

$$\sum_{d=1}^D \{(ICGC_d \div TotalWd_d) \times SP_{cd}\}$$

Where:

D: Number of days *d* in month *M*.

SP_{cd}: The Withdrawal Billing Units, in megawatt hours, of Transmission Customer *c* in day *d* that are used to supply Station Power as a third-party provider.

ICGC_d: The costs, in \$, for the Import Curtailment Guarantee Payments to Import Suppliers for day *d*.

TotalW_d: The sum, in megawatt hours, of Withdrawal Billing Units for all Transmission Customers in day *d*, except for Withdrawal Billing Units to supply Station Power as third-party providers and except for Scheduled Energy Withdrawals at a CTS Enabled Interface with ISO New England resulting from Exports that are not associated with wheels through New England.

M.11.3. Calculation of the Import Curtailment Guarantee Credit

The NYISO will credit each Transmission Customer based on its Withdrawal Billing Units that are not used to supply Station Power as a third-party provider, an amount of the revenue collected through the Import Curtailment Guarantee charge recovered from third-party Station Power suppliers for each month. This credit will be calculated according to the following formula.

$$\sum_{d=1}^D \{ICGC_d \times (WdUnits_{cd} \div TotalWd_d)\}$$

Where:

- D:** Number of days d in month M .
- $ICGC_d$:** The sum of Import Curtailment Guarantee charges, in \$, for all Transmission Customers supplying Station Power as third-party providers for day d .
- $WdUnits_{cd}$:** The Withdrawal Billing Units, in megawatt hours, for Transmission Customer c in day d , except for Withdrawal Billing Units to supply Station Power as a third-party provider and except for Scheduled Energy Withdrawals at a CTS Enabled Interface with ISO New England resulting from Exports that are not associated with wheels through New England.
- $TotalWd_d$:** The sum, in megawatt hours, of Withdrawal Billing Units for all Transmission Customers in day d , except for the Withdrawal Billing Units to supply Station Power as third-party providers and except for Scheduled Energy Withdrawals at a CTS Enabled Interface with ISO New England resulting from Exports that are not associated with wheels through New England.

M.12. OATT Schedule 1 Charge – Local Reliability Bid Production Cost Guarantee Charge

M.12.1. Calculation of the Local Reliability Bid Production Cost Guarantee (BPCG) Charge for Transmission Customers Based on Withdrawal Billing Units Not Used to Supply Station Power under Part 5 of the NYISO OATT

The NYISO will charge, and each Transmission Customer that serves Load in the Subzone where the Resource is located will pay based on its Withdrawal Billing Units that are not used to supply Station Power as a third-party provider, a charge in accordance with the following formula for each Subzone:

$$\sum_{d=1}^D \{BPCGCosts_d \times (SZWdUnits_{cd} \div SZTotalWd_d)\}$$

Where:

- D:** Number of days d in the month.
- $BPCGCosts_d$:** The Bid Production Cost Guarantee payments, in \$, made to Suppliers for Resources for day d in the relevant Subzone arising as a result of meeting the reliability needs of that Subzone, except for the BPCG payments made to Suppliers for SCRs.
- $SZWdUnits_{cd}$:** The Withdrawal Billing Units, in megawatt hours, for Transmission Customer c in day d in the relevant Subzone, except for Withdrawal Billing Units for Wheels Through, Exports, and to supply Station Power as a third-party provider.

$SZTotalWd_d$: The sum, in megawatt hours, of Withdrawal Billing Units for all Transmission Customers in day d in the relevant Subzone, except for Withdrawal Billing Units for Wheels Through, Exports, and to supply Station Power as third-party providers.

M.12.2. Calculation of the Local Reliability BPCG Charge for Transmission Customers Based on Withdrawal Billing Units to Supply Station Power under Part 5 of the NYISO OATT

The NYISO will charge, and each Transmission Customer that serves Load in the Subzone where the Resource is located will pay based on its Withdrawal Billing Units used to supply Station Power as a third-party provider, a charge in accordance with the following formula for each Subzone.

$$\sum_{d=1}^N \{(BPCGCosts_d \div SZTotalWd_d) \times SZSP_{cd}\}$$

Where:

N: Number of days d in month M .

$SZSP_{cd}$: The Withdrawal Billing Units, in megawatt hours, of Transmission Customer c in day d in the relevant Subzone that are used to supply Station Power as a third-party provider, except for Withdrawal Billing Units for Wheels Through and Exports.

$BPCGCosts_d$: The BPCG payments, in \$, made to Suppliers for Resources for day d in the relevant Subzone arising as a result of meeting the reliability needs of that Subzone, except for the BPCG payments made to Suppliers for SCRs.

$SZTotalWd_d$: The sum, in megawatt hours, of Withdrawal Billing Units for all Transmission Customers in day d in the relevant Subzone, except for Withdrawal Billing Units for Wheels Through, Exports, and to supply Station Power as third-party providers.

M.12.3. Calculation of the Local Reliability BPCG Credit

The NYISO will calculate, and each Transmission Customer that serves Load in the Subzone where the Resource is located will receive based on its Withdrawal Billing Units that are not used to supply Station Power as a third-party provider, an amount of the revenue collected through the Local Reliability BPCG charge recovered from third-party Station Power providers. This credit will be calculated according to the following formula:

$$\sum_{d=1}^D \{LRRBPCGCh_d \times (SZWdUnits_{cd} \div SZTotalWd_d)\}$$

Where:

D: Number of days d in month M .

$LRRBPCGCh_d$: The sum of Local Reliability BPCG charges, in \$, for all Transmission Customers that supply Power as third-party providers in the relevant Subzone as calculated above for day d .

$SZWdUnits_{cd}$: The Withdrawal Billing Units, in megawatt hours, for Transmission Customer c in day d in the relevant Subzone, except for Withdrawal Billing Units for Wheels Through, Exports, and to supply Station Power as a third-party provider.

$SZTotalWd_d$: The sum, in megawatt hours, of Withdrawal Billing Units for all Transmission Customers in day d in the relevant Subzone, except for Withdrawal Billing Units for Wheels Through, Exports, and to supply Station Power as third-party providers.

M.13. OATT Schedule 1 Charge – Local Reliability SCR BPCG Charge

The NYISO will recover the costs of BPCG payments incurred to compensate SCRs called to meet the reliability needs of a local system. To do so, the NYISO will charge, and each Transmission Customer that serves Load in the Subzone where the SCR is located will pay based on its Withdrawal Billing Units that are not used to provide Station Power as third-party providers, a charge in accordance with the following formula for each Subzone.

$$\sum_{d=1}^D \{BPCGCosts_d \times (SZWdUnits_{cd} \div SZTotalWd_d)\}$$

Where:

D: Number of days d in month M ,

$BPCGCosts_d$: The BPCG payments, in \$, made to Suppliers for SCRs for day d in the relevant Subzone arising as a result of meeting the reliability needs of that Subzone.

$SZWdUnits_{cd}$: The Withdrawal Billing Units, in megawatt hours, for Transmission Customer c in day d in the relevant Subzone, except for Withdrawal Billing Units for Wheels Through, Exports, and to supply Station Power as a third-party provider.

$SZTotalWd_d$: The sum, in megawatt hours, of Withdrawal Billing Units for all Transmission Customers in day d in the relevant Subzone, except for Withdrawal Billing Units for Wheels Through, Exports, and to supply Station Power as third-party providers.

M.14. OATT Schedule 1 Charge – NYCA Reliability SCR BPCG Charge

The NYISO will recover the costs for BPCG payments to compensate SCRs called to meet the reliability needs of the NYCA. To do so, the NYISO will charge, and each Transmission Customer that serves Load in the NYCA will pay based on its Withdrawal Billing Units except for the Withdrawal Billing Units for Wheels Through, Exports, or to provide Station power as a third-party provider, a charge in accordance with the following formula.

$$\sum_{d=1}^D \{BPCGCosts_d \times (WdUnits_{cd} \div TotalWd_d)\}$$

Where:

- D: Number of days d in the month,
- $BPCGCosts_d$: The BPCG payments, in \$, made to Suppliers for SCRs called to meet the reliability needs of the NYCA for day d .
- $WdUnits_{cd}$: The Withdrawal Billing Units, in megawatt hours, for Transmission Customer c in day d , except for the Withdrawal Billing Units for Wheels Through, Exports, or to supply Station Power as a third-party provider.
- $TotalWd_d$: The sum, in megawatt hours, of Withdrawal Billing Units for all Transmission Customers in day d , except for Withdrawal Billing Units for Wheels Through, Exports, or to supply Station Power as third-party providers.

M.15. OATT Rate Schedule 1 Charge – NYCA Reliability BPCG Charge

M.15.1. Calculation of the NYCA Reliability BPCG Charge for Transmission Customers Based on Withdrawal Billing Units Not Used to Supply Station Power under Part 5 of the NYISO OATT

The NYISO will charge, and each Transmission Customer will pay based on its Withdrawal Billing Units that are not used to supply Station Power as a third-party provider, a charge in accordance with the following formula:

$$\sum_{d=1}^D \{BPCGCosts_d \times (WdUnits_{cd} \div TotalWd_d)\}$$

Where:

- D: Number of days d in month M ,
- $BPCGCosts_d$: The BPCG costs, in \$, for day d not recovered by the NYISO through Sections 8.1.12.1, 8.1.12.2, 8.1.12.3, 8.1.12.4, and 8.1.12.5 of this manual.
- $WdUnits_{cd}$: The Withdrawal Billing Units, in megawatt hours, for Transmission Customer c in day d , except for the Withdrawal Billing Units to supply Station Power as a third-party provider and except for Scheduled Energy Withdrawals at a CTS Enabled Interface with ISO New England resulting from Exports that are not associated with wheels through New England.
- $TotalWd_d$: The sum, in megawatt hours, of Withdrawal Billing Units for all Transmission Customers in day d , except for the Withdrawal Billing Units to supply Station Power as third-party providers and except for Scheduled Energy Withdrawals at a CTS Enabled Interface with ISO New England resulting from Exports that are not associated with wheels through New England.

M.15.2. Calculation of the NYCA Reliability BPCG Charge for Transmission Customers Based on Withdrawal Billing Units to Supply Station Power under Part 5 of the NYISO OATT

The NYISO will charge, and each Transmission Customer will pay based on its Withdrawal Billing Units used to supply Station Power as a third-party provider, a charge in accordance with the following formula:

$$\sum_{d=1}^D \{(BPCGCosts_d \div TotalWd_d) \times SP_{cd}\}$$

Where:

- D: Number of days d in month M .
- SP_{cd} : The Withdrawal Billing Units, in megawatt hours, of Transmission Customer c in day d that are used to supply Station Power as a third-party provider.
- $BPCGCosts_d$: The BPCG costs, in \$, for day d not recovered by the NYISO through Sections 8.1.12.1, 8.1.12.2, 8.1.12.3, 8.1.12.4, and 8.1.12.5 of this manual.
- $TotalWd_d$: The sum, in megawatt hours, of Withdrawal Billing Units for all Transmission Customers in day d , except for the Withdrawal Billing Units to supply Station Power as third-party providers and except for Scheduled Energy Withdrawals at a CTS Enabled Interface with ISO New England resulting from Exports that are not associated with wheels through New England..

M.15.3. Calculation of the NYCA Reliability BPCG Credit

The NYISO will calculate, and each Transmission Customer will receive based on its Withdrawal Billing Units that are not used to supply Station Power as a third-party provider, an amount of the revenue collected through the NYCA Reliability BPCG charge recovered from third-party Station Power providers. This credit will be calculated according to the following formula.

$$\sum_{d=1}^D \{NYCABPCGCh_d \times (WdUnits_{cd} \div TotalWd_d)\}$$

Where:

- D: Number of days d in month M .
- $NYCABPCGCh_d$: The sum of NYCA Reliability BPCG charges, in \$, for all Transmission Customers supplying Station Power as third-party Station Power providers for day d .
- $WdUnits_{cd}$: The Withdrawal Billing Units, in megawatt hours, for Transmission Customer c in day d , except for the Withdrawal Billing Units to supply Station Power as a third-party provider and except for Scheduled Energy Withdrawals at a CTS Enabled Interface with ISO New England resulting from Exports that are not associated with wheels through New England.

TotalWd_d: The sum, in megawatt hours, of Withdrawal Billing Units for all Transmission Customers in day *d*, except for the Withdrawal Billing Units to supply Station Power as third-party providers and except for Scheduled Energy Withdrawals at a CTS Enabled Interface with ISO New England resulting from Exports that are not associated with wheels through New England.

M.16. OATT Schedule 1 Charge – Dispute Resolution Payment/Charge

The NYISO will calculate, and each Transmission Customer will receive or pay, a dispute resolution payment or charge in accordance with Section 8.1.13 of this manual for the distribution of funds received by the NYISO or the recovery of funds incurred by the NYISO in the settlement of a dispute.

$$DRCosts_M \times (WdUnits_{cM} \div TotalWd_M)$$

Where:

DRCosts_M: The amount, in \$, for month *M* that (i) the NYISO has collected in the settlement of a dispute or (ii) the NYISO has incurred in the settlement of a dispute.

WdUnits_{cM}: The Withdrawal Billing Units, in megawatt hours, for Transmission Customer *c* in month *M*, except for Scheduled Energy Withdrawals at a CTS Enabled Interface with ISO New England resulting from Exports that are not associated with wheels through New England..

TotalWd_M: The sum, in megawatt hours, of Withdrawal Billing Units for all Transmission Customers in month *M*, except for Scheduled Energy Withdrawals at a CTS Enabled Interface with ISO New England resulting from Exports that are not associated with wheels through New England.

M.17. OATT Schedule 1 Charge – Credit for Financial Penalties

The NYISO will distribute to each Transmission Customer on a monthly basis in accordance with the following formula any payments that it has collected from Transmission Customers to satisfy: (i) Financial Impact Charges issued pursuant to Sections 4.5.3.2 and 4.5.4.2 of the *NYISO Services Tariff*; (ii) ICAP sanctions issued pursuant to Section 5.12.12 of the *NYISO Services Tariff*; (iii) ICAP deficiency charges pursuant to Section 5.14.3.1 of the *NYISO Services Tariff*, except as provided in Section 5.14.3.2 of the *NYISO Services Tariff*; (iv) market power mitigation financial penalties pursuant to Section 23.4.3.6 of Attachment H of the *NYISO Services Tariff*, except as provided in Section 23.4.4.3.2 of Attachment H of the *NYISO Services Tariff*; and (v) any other financial penalties set forth in the *NYISO Services Tariff* or the *NYISO OATT*. The NYISO will perform this calculation separately for the allocation of the revenue from each financial penalty.

$$PenRev_M \times (WdUnits_{cM} \div TotalWd_M)$$

Where:

- PenRev_M*: The sum, in \$, of revenue that the NYISO has collected for month *M* from a Transmission Customer for one of the financial penalties indicated in Section 8.1.14 of this manual.
- WdUnits_{cM}*: The Withdrawal Billing Units, in megawatt hours, for Transmission Customer *c* in month *M*, except for Scheduled Energy Withdrawals at a CTS Enabled Interface with ISO New England resulting from Exports that are not associated with wheels through New England.
- TotalWd_M*: The sum, in megawatt hours, of Withdrawal Billing Units for all Transmission Customers in month *M*, except for Scheduled Energy Withdrawals at a CTS Enabled Interface with ISO New England resulting from Exports that are not associated with wheels through New England.

M.18. FERC Fee Charge –

M.18.1. Calculation of Physical FERC Fee Charge for Transmission Customers Participating in Physical Market Activity

Physical FERC Fee Charge_{c,P}

$$= \left(Injection\ Units_{c,P} * \left(0.28 * PRatio * \frac{(Est\ FERC\ Fee_P + True-Up\ Costs_P)}{TotalInjectionUnits_P} \right) \right) + \left(Withdrawal\ Units_{c,P} * \left(0.72 * PRatio * \frac{(Est\ FERC\ Fee_P + True-Up\ Costs_P)}{TotalWithdrawalUnits_P} \right) \right)$$

Where:

- c*: Transmission Customer;
- P*: The relevant Billing Period;
- Physical FERC Fee Charge_{c,P}*: The amount, in \$, of the annual FERC Fee for which Transmission Customer *c* is responsible for Billing Period *P*;
- Injection Units_{c,P}*: The Injection Billing Units, in MWh, for Transmission Customer *c* in Billing Period *P*. For an Energy Storage Resource, or DER Aggregation, the injection billing unit will be the sum of the injection MWh plus the absolute value of the withdrawal MWh. In addition, Demand Reduction by a DER Aggregation shall be included as Injection Billing Units;
- PRatio*: Ninety-four percent (94%);
- Est FERC Fee_P*: Billing Period *P*'s proportional allocation of the estimated annual FERC fee for the current FERC fiscal year;
- True-up Costs_P*: Billing Period *P*'s proportional allocation of the difference between the invoiced annual FERC fee and the estimated annual FERC fee;

$TotalInjectionUnits_P$:	The sum, in MWh, of Injection Billing Units for all Transmission Customers in Billing Period P;
$WithdrawalUnits_{c,P}$:	The Withdrawal Billing Units, in MWh, for Transmission Customer c in the Billing Period P;
$TotalWithdrawalUnits_P$:	The sum, in MWh, of Withdrawal Billing Units for all Transmission Customers in the Billing Period P.

M.18.2. Calculation of the FERC Fee Charge for Transmission Customers Participating in Non-Physical Market Activity

Non-Physical FERC Fee Charge c,P

$$= \left(VT_{Cleared}_{c,P} * \left(\frac{VTRatio * Est\ FERC\ Fee_P}{Total\ VT\ Cleared_P} \right) + \left(\frac{VTRatio * True-Up\ Costs_P}{Total\ VT\ Cleared_P} \right) \right) + \left(TCC\ Settled_{c,P} * \left(\frac{TCCRatio * Est\ FERC\ Fee_P}{Total\ TCC\ Settled_P} \right) + \left(\frac{TCCRatio * True-Up\ Costs_P}{Total\ TCC\ Settled_P} \right) \right)$$

Where:

C :	Transmission Customer.
P :	The relevant Billing Period.
$Non - Physical\ FERC\ Fee\ Charge_{c,P}$:	The amount, in \$, of the annual FERC fee for which Transmission Customer c is responsible for Billing Period P ;
$VT\ Cleared_{c,P}$:	The total cleared Virtual Transactions, in MWh, for Transmission Customer c in Billing Period P ;
$Est\ FERC\ Fee_P$:	Billing Period P 's proportional allocation of the estimated annual FERC fee for the current FERC fiscal year;
$True - up\ Costs_P$:	Billing Period P 's proportional allocation of the difference between the invoiced annual FERC fee and the estimated annual FERC fee;
$VTRatio$:	Approximately two percent (2%);
$Total\ VT\ Cleared_P$:	The sum, in MWh, of cleared Virtual Transactions for all Transmission Customers in Billing Period P ;
$TCCSettled_{c,P}$:	The total settled Transmission Congestion Contracts, in MWh, for Transmission Customer c in Billing Period P ;
$TCCRatio$:	Approximately four percent (4%);
$Total\ TCC\ Settled_P$:	The total settled Transmission Congestion Contracts, in MWh, for Transmission Customer c in Billing Period P .

M.19. OATT Voltage Support Service Charge -

M.19.1. LSEs NOT taking service under Section 5 of the OATT to supply Station Power and Transmission Customers engaging in Wheels Through, Exports and Purchases from the LBMP Market where the Energy is delivered to a NYCA interconnection with another Control Area

$$\sum_{d=1}^D \left\{ \left[\frac{EVSS\$_a + PVSS\$_a}{FWd_a^{LSE} + FWd_a^{WT} + FWd_a^{Exp} + FWd_a^{LExp}} \times \sum_{n=1}^N (AWd_{lh}^{LSE} + AWd_{th}^{WT} + AWd_{th}^{TExp} + AWd_{th}^{LExp}) \right] - \left[\frac{\sum_{n=1}^N (AWd_{lh}^{LSE} + AWd_{th}^{WT} + AWd_{th}^{TExp} + AWd_{th}^{LExp})}{\sum_{n=1}^N (AWd_h^{LSE} + AWd_h^{WT} + AWd_h^{TExp} + AWd_h^{LExp})} \times SPVSS\$_d^{LSE} \right] \right\}$$

Where:

- D:** Number of days d in the month;
- N:** Number of hours h in the day;
- EVSS\$_a:** The sum of the projected NYISO payments to generation facilities and Qualified Non-Generator Voltage Support Resources providing Voltage Support Service based on Sections 15.2.2.1, 15.2.2.2, and 15.2.2.3 of Rate Schedule 2 of the NYISO Market Administration and Control Area Services Tariff (Services Tariff), expressed in dollars (\$);
- PVSS\$_a:** Total of prior year payments to generation facilities and Qualified Non-Generator Voltage Support Resources supplying Voltage Support Service as defined in the NYISO Services Tariff less the total of payments received by the NYISO from Transmission Customers and LSEs in the prior year for Voltage Support Service (including all payments for penalties), expressed in dollars (\$);
- FWd_a^{LSE}:** Forecasted annual LSE Energy Withdrawals, expressed in MWhs;
- FWd_a^{WT}:** Forecasted annual Wheels Through, expressed in MWhs;
- FWd_a^{Exp}:** Forecasted annual Export Transaction Energy, expressed in MWhs except for Export Transactions at a CTS Enabled Interface with ISO New England resulting from Exports that are not associated with wheels through New England;
- FWd_a^{LExp}:** Forecasted Annual LBMP Export Energy scheduled for hour h , expressed in MWhs except for Export Transactions at a CTS Enabled Interface with ISO New England resulting from Exports that are not associated with wheels through New England;
- AWd_{lh}^{LSE}:** Actual LSE Energy Withdrawals for hour h for LSE l , expressed in MWhs;
- AWd_{th}^{WT}:** Actual Wheels Through scheduled for hour h for Transmission Customer t , expressed in MWhs;
- AWd_{th}^{TExp}:** Actual Export Transactions scheduled for hour h for Transmission Customer t , expressed in MWhs except for Export Transactions at a CTS Enabled Interface with ISO New England resulting from Exports that are not associated with wheels through New England;

- AWd_{th}^{LExp} : Actual LBMP Export Energy scheduled for hour h for Transmission Customer t , expressed in MWhs except for Export Transactions at a CTS Enabled Interface with ISO New England resulting from Exports that are not associated with wheels through New England;
- WU_h^{LSE} : Total Actual LSE Energy Withdrawals NYCA-wide for hour h , expressed in MWhs;
- WU_h^{WT} : Total Actual Wheels Through scheduled NYCA-wide for hour h , expressed in MWhs;
- WU_h^{Exp} : Total Actual Export Transactions scheduled NYCA-wide for hour h , expressed in MWhs except for Export Transactions at a CTS Enabled Interface with ISO New England resulting from Exports that are not associated with wheels through New England;
- WU_h^{LExp} : Total Actual LBMP Export Energy scheduled NYCA-wide for hour h , expressed in MWhs except for Export Transactions at a CTS Enabled Interface with ISO New England resulting from Exports that are not associated with wheels through New England;
- $SPVSS_d^{LSE}$: Voltage Support Service revenue collected from LSEs taking service under Section 5 of the OATT to supply Station Power in day d , as determined below, expressed in dollars (\$);

M.19.2. LSEs taking service under Section 5 of the OATT to supply Station Power

$$\sum_{d=1}^D \left\{ \left[\frac{EVSS\$_a + PVSS\$_a}{FWd_a^{LSE} + FWd_a^{WT} + FWd_a^{Exp} + FWd_a^{LExp}} \right] \times \sum_{n=1}^N AWd_h^{SPLE} \right\}$$

Where:

- D : Number of days d in the month;
- N : Number of hours h in the day;
- $EVSS\$_a$: The sum of the projected NYISO payments to generation facilities and Qualified Non-Generator Voltage Support Resources providing Voltage Support Service based on Sections 15.2.2.1, 15.2.2.2, and 15.2.2.3 of Rate Schedule 2 of the *NYISO Services Tariff*, expressed in dollars (\$);
- $PVSS\$_a$: Total of prior year payments to generation facilities and Qualified Non-Generator Voltage Support Resources supplying Voltage Support Service as defined in the *NYISO Services Tariff* less the total of payments received by the NYISO from Transmission Customers and LSEs in the prior year for Voltage Support Service (including all payments for penalties), expressed in dollars (\$);
- FWd_a^{LSE} : Forecasted annual LSE Energy Withdrawals, expressed in MWhs;
- FWd_a^{WT} : Forecasted annual Wheels Through, expressed in MWhs;
- FWd_a^{Exp} : Forecasted annual Export Transaction Energy, expressed in MWhs except for Export Transactions at a CTS Enabled Interface with ISO New England resulting from Exports that are not associated with wheels through New England;

- FWd_a^{LExp} : Forecasted Annual LBMP Export Energy scheduled for hour h , expressed in MWhs except for Export Transactions at a CTS Enabled Interface with ISO New England resulting from Exports that are not associated with wheels through New England;
- AWd_h^{SPLESE} : Actual LSE Energy Withdrawal for LSEs taking service under Section 5 of the OATT to supply Station Power in hour h , expressed in MWhs;

M.20. OATT Regulation and Frequency Response Service Charge

M.20.1. LSEs NOT taking service under Section 5 of the OATT to supply Station Power

$$\sum_{d=1}^D \left\{ \left[\sum_{h=1}^N \left(\frac{Reg\$_h + RegC_h - UGP_h^G}{\sum_{h=1}^N AWd_h^{LSE}} \times AWd_{lh}^{LSE} \right) \right] - \left[\frac{\sum_{h=1}^N AWd_{lh}^{LSE}}{\sum_{h=1}^N AWd_h^{LSE}} \times SPReg\$_d^{LSE} \right] \right\}$$

Where:

- D : Number of days (d) in the month;
- N : Number of hours (h) in the day;
- $Reg\$_h$: Total payments made by the NYISO to Suppliers of Regulation Services, including all Day-Ahead Market and Real-Time Market payments and Regulation Revenue Adjustment Payments, as described in Rate Schedule 3 of the NYISO Services Tariff for the hour, expressed in dollars (\$);
- $RegC_h$: Total charges assessed by the NYISO to Suppliers of Regulation Service, including: (i) charges paid by all Suppliers for poor Regulation Service performance, as described in Section 15.3.5.5; (ii) all real-time imbalance charges paid by Suppliers under Section 15.3.5.3 (a) of that Rate Schedule; and (iii) all Regulation Revenue Adjustment Charges assessed pursuant to Section 15.3.6 of that Rate Schedule for hour h , expressed in dollars (\$);
- UGP_h^G : Total charges assessed by the NYISO to Suppliers that do not provide Regulation Service and do not follow their RTD Base Points with sufficient accuracy, as described in Rate Schedule 3-A (Section 15.3A) of the NYISO Services Tariff, for hour h , expressed in dollars (\$);
- AWd_{lh}^{LSE} : Actual LSE Energy Withdrawal for LSE l in hour h , expressed in MWhs;
- AWd_h^{LSE} : Total Actual LSE Energy Withdrawals NYCA-wide in hour h , expressed in MWhs;
- $SPReg\$_d^{LSE}$: Total Regulation and Frequency Response Service revenue collected from LSEs taking service under Section 5 of the OATT to supply Station Power in day d , as determined below, expressed in dollars (\$);

M.20.2. LSEs taking service under Section 5 of the OATT to supply Station Power

$$\sum_{d=1}^D \left\{ \left[\frac{\sum_{h=1}^N (Reg\$_h + RegC_h - UGP_h^G)}{\sum_{h=1}^N AWd_h^{LSE}} \right] \times \sum_{h=1}^N AWd_h^{SPLESE} \right\}$$

Where:

- D : Number of days d in the month;
- N : Number of hours h in the day;
- $Reg\$_h$: The sum of all Day-Ahead Market and Real-Time Market payments (including Regulation Revenue Adjustment Payments) made by the NYISO to all Suppliers of Regulation Service as described in Sections 15.3.4, 15.3.5, 15.3.6, and 15.3.7 of Rate Schedule 3 of the NYISO Services Tariff for hour h , expressed in dollars (\$);
- $RegC_h$: The sum of: (i) charges paid by all Suppliers for poor Regulation Service performance, as described in Section 15.3.5.5 and, if its provisions are re-instituted, Section 15.3.8 of Rate Schedule 3 of the NYISO Services Tariff; (ii) all real-time imbalance charges paid by Suppliers under Section 15.3.5.3 (a) of that Rate Schedule; and (iii) all Regulation Revenue Adjustment Charges assessed pursuant to Section 15.3.6 of that Rate Schedule for hour h , expressed in dollars (\$);
- UGP_h^G : The sum of charges paid by Generators that do not provide Regulation Service and do not follow their RTD Base Points sufficiently accurately, as described in Rate Schedule 3-A (Section 15.3A) of the NYISO Services Tariff for the hour or for the day, expressed in dollars (\$);
- AWd_h^{LSE} : Total Actual LSE Energy Withdrawals NYCA-wide in hour h , expressed in MWs;
- AWd_h^{SPLSE} : Actual LSE Energy Withdrawal for LSEs taking service under Section 5 of the OATT to supply Station Power in hour h , expressed in MWs;

M.21. OATT Operating Reserves Service Charge -

M.21.1. LSEs NOT taking service under Section 5 of the OATT to supply Station Power and Transmission Customers engaging in Exports and Purchases from the LBMP Market where the Energy is delivered to a NYCA interconnection with another Control Area

$$\sum_{N=1}^M \left\{ \left[\sum_{n=1}^N \left(\frac{SORS_h}{WU_h^{LSE} + WU_h^{Exp} + WU_h^{LExp}} \times \{WU_{lh}^{LSE} + WU_{th}^{Exp} + WU_{th}^{LExp}\} \right) \right] - \left[\frac{\sum_{n=1}^N (WU_{lh}^{LSE} + WU_{th}^{Exp} + WU_{th}^{LExp})}{\sum_n (WU_h^{LSE} + WU_h^{Exp} + WU_h^{LExp})} \times SPORS_d^{Rev} \right] \right\}$$

Where:

- M : Number of days d in the month;
- N : Number of hours h in the day;
- $SORS_h$: Total hourly cost to procure Operating Reserves on behalf of the NYCA in the Day-Ahead Market and the Real-Time Market, less payments collected from entities that are scheduled to provide less Operating Reserves in the Real-Time Market than in the Day-

Ahead Market during that hour, under Rate Schedule 4 (Section 15.4) of the NYISO Services Tariff, expressed in dollars (\$);

- WU_h^{LSE} : Total Actual LSE Energy Withdrawals NYCA-wide in hour h , expressed in MWhs;
- WU_h^{Exp} : Total Actual Export Energy scheduled NYCA-wide in hour h , expressed in MWhs except for Export Transactions at a CTS Enabled Interface with ISO New England resulting from Exports that are not associated with wheels through New England;
- WU_h^{LExp} : Total Actual LBMP Export Energy scheduled NYCA-wide in hour h , expressed in MWhs except for Export Transactions at a CTS Enabled Interface with ISO New England resulting from Exports that are not associated with wheels through New England;
- WU_{lh}^{LSE} : Actual LSE Energy Withdrawal in hour h for LSE l , expressed in MWhs;
- WU_{th}^{Exp} : Total Actual Export Energy scheduled in hour h for Transmission Customer t , expressed in MWhs except for Export Transactions at a CTS Enabled Interface with ISO New England resulting from Exports that are not associated with wheels through New England;
- WU_{th}^{LExp} : Total Actual LBMP Export Energy scheduled in hour h for Transmission Customer t , expressed in MWhs except for Export Transactions at a CTS Enabled Interface with ISO New England resulting from Exports that are not associated with wheels through New England;
- $SPORS_d^{Rev}$: Operating Reserves Service revenue collected from LSEs taking service under Section 5 of the OATT to supply Station Power in day d , as determined below, expressed in dollars (\$);

M.21.2. LSEs taking service under Section 5 of the OATT to supply Station Power

$$\sum_{N=1}^M \left\{ \sum_{n=1}^N \left[\frac{SORS_h}{(WU_h^{LSE} + WU_h^{Exp} + WU_h^{LExp})} \times WU_h^{SPLSE} \right] \right\}$$

Where:

- M : Number of days d in the month;
- N : Number of hours h in the day;
- $SORS_h$: The sum of the cost to the NYISO of providing Operating Reserves in each hour to procure Operating Reserves on behalf of the market in the Day-Ahead Market and the Real-Time Market, less payments collected from entities that are scheduled to provide less Operating Reserves in the Real-Time Market than in the Day-Ahead Market during that hour, under Rate Schedule 4 (Section 15.4) of the NYISO Services Tariff, expressed in dollars (\$);
- WU_h^{LSE} : Total Actual LSE Energy Withdrawals NYCA-wide in hour h , expressed in MWhs;
- WU_h^{Exp} : Total Actual Export Energy scheduled NYCA-wide in hour h , expressed in MWhs except for Export Transactions at a CTS Enabled Interface with ISO New England resulting from Exports that are not associated with wheels through New England;

WU_h^{LEXP} : Total Actual LBMP Export Energy scheduled NYCA-wide in hour h , expressed in MWhs except for Export Transactions at a CTS Enabled Interface with ISO New England resulting from Exports that are not associated with wheels through New England;

WU_h^{SPLSE} : Actual LSE Energy Withdrawal for LSEs taking service under Section 5 of the OATT to supply Station Power in hour h , expressed in terms of megawatt hours;

M.22. OATT Black Start and System Restoration Service Charge

M.22.1. LSEs NOT taking service under Section 5 of the OATT to supply Station Power

$$\sum_{N=1}^M \left\{ \left[\sum_{n=1}^N \left(\frac{BSSRS_h}{WU_h^{LSE}} \times WU_{lh}^{LSE} \right) \right] - \left[\frac{\sum_{n=1}^N WU_{lh}^{LSE}}{\sum_{n=1}^N WU_h^{LSE}} \times SPBSSRS_d^{Rev} \right] \right\}$$

Where:

M : Number of days d in the month;

N : Number of hours h in the day;

$BSSRS_h$: The hourly embedded cost for Black Start and System Restoration Services supplied by Generators that are part of the NYISO Plan, net of all payments forfeited due to a Generator's failure to pass a required test of its ability to provide Black Start and System Restoration Services, expressed in dollars (\$);

WU_{lh}^{LSE} : Actual LSE Energy Withdrawal for LSE l in hour h , expressed in MWhs;

WU_h^{LSE} : Total Actual LSE Energy Withdrawals NYCA-wide in hour h , expressed in MWhs;

$SPBSSRS_d^{Rev}$: Total Black Start and System Restoration Service revenue collected from LSEs taking service under Section 5 of the OATT to supply Station Power in day d , as determined below, expressed in dollars (\$);

M.22.2. LSEs taking service under Section 5 of the OATT to supply Station Power

$$\sum_{N=1}^M \left\{ \left(\frac{\sum_{n=1}^N BSSRS_h}{\sum_{n=1}^N WU_h^{LSE}} \times \sum_{n=1}^N WU_h^{SPLSE} \right) \right\}$$

Where:

M : Number of days d in the month;

N : Number of hours h in the day;

$BSSRS_h$: The hourly embedded cost for Black Start and System Restoration Services supplied by Generators that are part of the NYISO Plan, net of all payments forfeited due to a Generator's failure to pass a required test of its ability to provide Black Start and System Restoration Services, expressed in dollars (\$);

WU_h^{LSE} : Total Actual LSE Energy Withdrawals NYCA-wide in hour h , expressed in MWhs;

WU_h^{SPLSE} : Actual LSE Energy Withdrawal for LSEs taking service under Section 5 of the OATT to supply Station Power in hour h , expressed in MWhs;

M.22.3. LSEs NOT taking service under Section 5 of the OATT to supply Station Power

$$\sum_{N=1}^M \left\{ \left[\sum_{n=1}^N \left(\frac{LBSSRS_h}{WU_h^{LSE}} \times WU_{lh}^{LSE} \right) \right] - \left[\frac{\sum_{n=1}^N WU_{lh}^{LSE}}{\sum_{n=1}^N WU_h^{LSE}} \times SPLBSSRS_d^{Rev} \right] \right\}$$

Where:

M : Number of days d in the month;

N : Number of hours h in the day;

$LBSSRS_h$: The hourly embedded cost for Black Start and System Restoration Services supplied by Generators that are part of a Transmission Owner’s local Black Start and System Restoration Plan, net of all payments forfeited due to a Generator’s failure to pass a required test of its ability to provide local Black Start and System Restoration Services, expressed in dollars (\$);

WU_{lh}^{LSE} : Actual LSE Energy Withdrawal for LSE l within the respective Transmission Owner’s transmission district to which the local Black Start and System Restoration Plan pertains in hour h , expressed in MWhs;

WU_h^{LSE} : Total Actual LSE Energy Withdrawals within the respective Transmission Owner’s transmission district to which the local Black Start and System Restoration Plan pertains in hour h , expressed in MWhs;

$SPLBSSRS_d^{Rev}$: Total Black Start and System Restoration Service revenue collected from LSEs taking service under Section 5 of the OATT to supply Station Power within the respective Transmission Owner’s transmission district to which the local Black Start and System Restoration Plan pertains in day d , as determined below, expressed in dollars (\$);

M.22.4. LSEs taking service under Section 5 of the OATT to supply Station Power

$$\sum_{N=1}^M \left\{ \left(\frac{\sum_{n=1}^N BSSRS_h}{\sum_{n=1}^N WU_h^{LSE}} \times \sum_{n=1}^N WU_h^{SPLSE} \right) \right\}$$

Where:

M : Number of days d in the month;

N : Number of hours h in the day;

$BSSRS_h$: The hourly embedded cost for Black Start and System Restoration Services supplied by Generators that are part of a Transmission Owner’s local Black Start and System Restoration Plan, net of all payments forfeited due to a Generator’s failure to pass a required test of its ability to provide local Black Start and System Restoration Services, expressed in dollars (\$);

- WU_h^{LSE} : Total Actual LSE Energy Withdrawals within the respective Transmission Owner’s transmission district to which the local Black Start and System Restoration Plan pertains in hour h , expressed in MWhs;
- $WU_h^{SP LSE}$: Actual LSE Energy Withdrawal for LSEs taking service under Section 5 of the OATT to supply Station Power within the respective Transmission Owner’s transmission district to which the local Black Start and System Restoration Plan pertains in hour h , expressed in MWhs;

M.23. Monthly Power Supplier Intermittent Power Resource Forecasting Charge

$$\$500 + (\$6.20 \times C)$$

Where:

C : Name Plate capacity, expressed in MWs

M.24. Rate Mechanism for the Recovery of the Reliability Facilities Charge (“RFC”)

The RFC is to be billed by the NYISO and paid by the LSEs located in the Load Zones and/or Subzones to which the cost of the transmission facilities have been allocated in accordance with Attachment Y of the NYISO OATT. All LSEs in the Load Zone and/or Subzones to which costs have been allocated, including Transmission Owners, competitive LSEs, and municipal systems, will be billed by the NYISO.

The Billing Units for the RFC Rate for the Billing Period shall be based on the Actual Energy Withdrawals available for the current Billing Period for those Load Zones and/or Subzones determined to be allocated the costs of the project in accordance with Attachment Y of the NYISO OATT.

Step 1: Calculate the \$ assigned to each Load Zone or Subzone (as applicable)

$$RFC_{z,B} = \sum_{p \in P} \left((AnnualRR_{p,B} - IncrementalTransmissionRightsRevenue_{p,B}) \times (ZonalCostAllocation\%_p) \right)$$

Step 2: Calculate a per-MWh Rate for each Load Zone or Subzone (as applicable)

$$RFCRate_{z,B} = RFC_{z,B} / MWh_{z,B}$$

Step 3: Calculate charge for each Billing Period for each LSE in each Load Zone or Subzone (as applicable)

$$Charge_{B,LZ} = RFCRate_{z,B} \times MWh_{LZ,B}$$

Step 4: Calculate charge for each Billing Period for each LSE across all Load Zones or Subzones (as applicable)

$$Charge_{B,l} = \sum_{z \in Z} (Charge_{B,l,z})$$

Where:

P :	Set of Projects.
Z :	Set of ISO Load Zones or Subzones as applicable.
B :	The relevant Billing Period.
$MWh_{z,B}$:	Actual Energy Withdrawals in Load Zone or Subzone, as applicable, z aggregated across all hours in Billing Period B .
$MWh_{l,z,B}$:	Actual Energy Withdrawals for LSE l in Load Zone or Subzone, as applicable, z aggregated across all hours in Billing Period B .
$AnnualRR_{p,B}$:	The pro rata share of the annual Revenue Requirement for each Project as discussed in OATT Section 6.10.2.2 allocated for Billing Period B .
$IncrementalTransmissionRightsRevenue_{p,B}$:	The pro rata share of the Incremental Transmission Rights Revenue for each Project as discussed in OATT Section 6.10.3.2 allocated for Billing Period B .

M.25. Rate Mechanism for the Recovery of the Transco Facilities Charge (“TFC”) – Cost Recovery

Methodology for All Responsible LSEs Except NYPA

The ISO shall calculate the TFC for each Responsible LSE as follows:

Step 1: Calculate the \$ assigned to each Transmission District

$$TFC_{t,B} = \sum_{p \in P} \left((AnnualRR_{p,B} - IncrementalTCCRevenue_{p,B} + OutageCostAdjustment_{p,B}) \times (TransmissionDistrictCostAllocation_{t,p}) \right)$$

Step 2: Calculate a per-MWh Rate for each Transmission District

$$TFCRate_{t,B} = TFC_{t,B} / MWh_{t,B}$$

Step 3: Calculate charge for each Billing Period for each Responsible LSE in each Transmission District

$$Charge_{B,l,t} = TFCRate_{t,B} \times MWh_{l,t,B}$$

Step 4: Calculate charge for each Billing Period for each Responsible LSE across all Transmission Districts

$$Charge_{B,l} = \sum_{t \in T} (Charge_{B,l,t})$$

Where:

<i>l</i> :	The relevant Responsible LSE;
<i>P</i> :	Set of projects;
<i>T</i> :	Set of ISO Transmission Districts;
<i>t</i> :	An individual Transmission District;
<i>B</i> :	The relevant Billing Period;
<i>MWh_{t,B}</i> :	Actual Energy Withdrawals in Transmission District t aggregated across all hours in Billing Period B;
<i>MWh_{l,t,B}</i> :	Actual Energy Withdrawals for Responsible LSE l in Transmission District t aggregated across all hours in Billing Period B;
<i>AnnualRR_{p,B}</i> :	The pro rata share of the annual revenue requirement for each project p as discussed in OATT Section 6.13.2 above allocated for Billing Period B;
<i>Incremental TCC Revenue_{p,B}</i> :	The auction revenue derived from the sale of Incremental TCCs plus Incremental TCC payments received by NY Transco pursuant to Section 20.2.3 of the ISO OATT for each project p as discussed in Section 6.13.3.2 above allocated for Billing Period B. The revenues from the sale of Incremental TCCs in the ISO's six month Sub-Auctions of each Centralized TCC Auction shall be allocated uniformly across all hours of the Billing Period B;
<i>Outage Cost Adjustment_{p,B}</i> :	The Outage Charges determined pursuant to OATT Section 6.13.3.2.1 for any hour in the Day-Ahead Market during which the project p is modeled to be wholly or partially out of service aggregated across all hours in Billing Period B;
<i>TransmissionDistrictCostAllocation_{t,p}</i> :	The proportion of the cost of project p allocated to Transmission District t, as set forth in OATT Section 36.2 of Attachment 1 to Attachment DD; provided, however, that the proportion of the cost of project p allocated to the NYPA North Subzone shall be included in the percentage for Niagara Mohawk Power Corporation d/b/a National Grid set forth in OATT Section 36.2.

M.26. Reliability Must Run

M.26.1. Calculation of RMR Charge for an RMR Generator Providing Service Under an Availability and Performance Rate

$$RMRCharge_{l,g,P} = \sum_{d \in P} \left((RMRAvoidCost_{g,d} + VarCost_{g,d} - MarketRev_{g,d}) * \sum_{z \in Z} (ZonalCostAllocation_{g,z} * (MWh_{l,z,d} / MWh_{z,d})) \right)$$

Where:

g = the relevant RMR Generator that is providing service under an Availability and Performance Rate;

P = the relevant Billing Period;

d = the relevant market day;

l = the relevant RMR LSE;

z = an individual NYCA Load Zone or Subzone (as applicable);

Z = the set of all Load Zones (or Subzones as applicable) that have nonzero allocations for the relevant RMR Generator;

$RMRCharge_{l,g,P}$ = the RMR Charge associated with RMR Generator g for Billing Period P for RMR LSE l ;

$RMRAvoidCost_{g,d}$ = the RMR Avoidable Cost amount for RMR Generator g for day d , that has been accepted for filing by the Commission, or as calculated by the ISO in accordance with Sections 31.2.11.8 and 31.2.11.17 of the OATT pending Commission action, shaped on a Capability Period basis, and Additional Costs in accordance with Section 38.16 of the OATT;

$VarCost_{g,d}$ = the Variable Cost amount for RMR Generator g for day d , calculated pursuant to Section 15.8.1 of Rate Schedule 8 to the ISO Services Tariff;

$MarketRev_{g,d}$ = the revenue recovered from Transmission Customers under the ISO Tariffs for day d in connection with the participation of the RMR Generator g in the ISO Administered Markets, including LBMP revenues, Ancillary Services revenues, guarantee or supplemental payments, Day-Ahead to real-time balancing settlements as described in Section 4 of the ISO Services Tariff, and monthly Capacity revenues divided by the number of days in the month;

$ZonalCostAllocation_{g,z}$ = the proportion of the cost of RMR Generator g allocated to Load Zone or Subzone (as applicable) z ;

$MWh_{z,d}$ = Actual Energy Withdrawals in Load Zone or Subzone (as applicable) z aggregated across all hours on day d ;

$MWh_{l,z,d}$ = Actual Energy Withdrawals for RMR LSE l in Load Zone or Subzone (as applicable) z aggregated across all hours on day d .

M.26.2. Calculation of RMR Charge for an RMR Generator Providing Service Under a Rate Other Than an Availability and Performance Rate

$$RMRCharge_{l,g,P} = \sum_{d \in P} \left((RMRCost_{g,d} + VarCost_{g,d} - MarketRev_{g,d}) * \sum_{z \in Z} (ZonalCostAllocation_{g,z} * (MWh_{l,z,d} / MWh_{z,d})) \right)$$

Where:

g = the relevant RMR Generator that is providing service under a rate other than an ISO-developed Availability and Performance Rate;

$RMRCost_{g,d}$ = the costs RMR Generator g is authorized to recover for day d pursuant to a rate approved for RMR Generator g by the Commission, or is recovering subject to refund pending Commission action, shaped on a Capability Period basis, and Additional Costs in accordance with Section 38.16 of the OATT.

The definitions of the remaining variables in this equation are identical to the definitions for such variables set forth above.

M.26.3. Calculation of RMR Charge for an Interim Service Provider

$$RMRCharge_{l,g,P} = \sum_{d \in P} \left((RMRAvoidCost_{g,d} + VarCost_{g,d} - MarketRev_{g,d}) * \sum_{z \in Z} (ZonalCostAllocation_{g,z} * (MWh_{l,z,d} / MWh_{z,d})) \right)$$

Where:

g = the relevant Interim Service Provider Generator;

Z = the set of all Load Zones (or Subzones as applicable) that have nonzero allocations for the relevant Interim Service Provider Generator;

$RMRCharge_{l,g,P}$ = the RMR Charge associated with Interim Service Provider Generator g for Billing Period P for RMR LSE l ;

$RMRAvoidCost_{g,d}$ = the Avoidable Cost amount for Interim Service Provider Generator g for day d calculated by the ISO in accordance with Sections 38.8, 38.16 and 38.17 of the OATT, shaped on a Capability Period basis;

$VarCost_{g,d}$ = the Variable Cost amount for Interim Service Provider Generator g for day d , calculated pursuant to Section 15.8.6 of Rate Schedule 8 to the ISO Services Tariff;

$MarketRev_{g,d}$ = the revenue recovered from Transmission Customers under the ISO Tariffs for day d in connection with the participation of the Interim Service Provider Generator g in the ISO Administered Markets, including LBMP revenues, Ancillary Services revenues, guarantee or supplemental payments, Day-Ahead to real-time balancing settlements as described in Section 4 of the ISO Services Tariff, and monthly Capacity revenues divided by the number of days in the month; and

$ZonalCostAllocation_{g,z}$ = the proportion of the cost of Interim Service Provider Generator g allocated to Load Zone or Subzone (as applicable) z .

The definitions of the remaining variables in this equation are identical to the definitions for such variables set forth above.

M.27. Recovery for Costs for Demand Reductions Associated with DER Aggregations

The “Schedule 1 Program Costs” for verified Actual Demand Reductions by DER Aggregations participating in the Energy and Ancillary Services Markets shall be equal to the Supplier payments for Demand Reductions calculated in accordance with ISO Services Tariff Section 4.5.2.

The “Schedule 1 Program Costs” for verified Demand Reductions by DER Aggregations participating in the Energy and Ancillary Services Markets shall be allocated to Transmission Customers, pursuant to the methodology set forth below, on the basis of their Load Ratio Shares and in proportion to the probability, given historical transmission congestion patterns, that a particular Demand Reduction will benefit them by reducing Energy costs in their Load Zones or “Composite Load Zones” (see below).

Schedule 1 Program Costs shall be allocated to Transmission Customers as follows:

For Transmission Customer m in Load Zones A-E:

$a_1 * (cost_A + \dots + cost_K) * load_m / (load_A + \dots + load_K) +$	'no constraints
$a_2 * (cost_A + \dots + cost_E) * load_m / (load_A + \dots + load_E) +$	'Central East const
$a_3 * (cost_A + \dots + cost_I + cost_K) * load_m / (load_A + \dots + load_I + load_K) +$	'NYC constraint
$a_4 * (cost_A + \dots + cost_J) * load_m / (load_A + \dots + load_J) +$	'LI constraint
$a_5 * (cost_A + \dots + cost_E) * load_m / (load_A + \dots + load_E) +$	'Cent East + NYC
$a_6 * (cost_A + \dots + cost_E) * load_m / (load_A + \dots + load_E) +$	'Cent East + LI
$a_7 * (cost_A + \dots + cost_I) * load_m / (load_A + \dots + load_I) +$	'NYC + LI
$a_8 * (cost_A + \dots + cost_E) * load_m / (load_A + \dots + load_E)$	'Cent East + NYC + LI

For Transmission Customer m in Load Zones F-I:

$a_1 * (cost_A + \dots + cost_K) * load_m / (load_A + \dots + load_K) +$	'no constraints
$a_2 * (cost_F + \dots + cost_K) * load_m / (load_F + \dots + load_K) +$	'Central East const
$a_3 * (cost_A + \dots + cost_I + cost_K) * load_m / (load_A + \dots + load_I + load_K) +$	'NYC constraint
$a_4 * (cost_A + \dots + cost_J) * load_m / (load_A + \dots + load_J) +$	'LI constraint
$a_5 * (cost_F + \dots + cost_I + cost_K) * load_m / (load_F + \dots + load_I + load_K) +$	'Cent East + NYC
$a_6 * (cost_F + \dots + cost_J) * load_m / (load_F + \dots + load_J) +$	'Cent East + LI
$a_7 * (cost_A + \dots + cost_I) * load_m / (load_A + \dots + load_I) +$	'NYC + LI
$a_8 * (cost_F + \dots + cost_I) * load_m / (load_F + \dots + load_I)$	'Cent East + NYC + LI

For Transmission Customer m in Load Zone J:

$a_1 * (cost_A + \dots + cost_K) * load_m / (load_A + \dots + load_K) +$	'no constraints
$a_2 * (cost_F + \dots + cost_K) * load_m / (load_F + \dots + load_K) +$	'Central East const
$a_3 * cost_J * load_m / load_J +$	'NYC constraint
$a_4 * (cost_A + \dots + cost_J) * load_m / (load_A + \dots + load_J) +$	'LI constraint
$a_5 * cost_J * load_m / load_J +$	'Cent East + NYC
$a_6 * (cost_F + \dots + cost_J) * load_m / (load_F + \dots + load_J) +$	'Cent East + LI
$a_7 * cost_J * load_m / load_J +$	'NYC + LI
$a_8 * cost_J * load_m / load_J$	'Cent East + NYC + LI

For Transmission Customer m in Load Zone K:

$a_1 * (cost_A + \dots + cost_K) * load_m / (load_A + \dots + load_K) +$	'no constraints
$a_2 * (cost_F + \dots + cost_K) * load_m / (load_F + \dots + load_K) +$	'Central East const
$a_3 * (cost_A + \dots + cost_I + cost_K) * load_m / (load_A + \dots + load_I + load_K) +$	'NYC constraint
$a_4 * cost_K * load_m / load_K +$	'LI constraint
$a_5 * (cost_F + \dots + cost_I + cost_K) * load_m / (load_F + \dots + load_I + load_K) +$	'Cent East + NYC
$a_6 * cost_K * load_m / load_K +$	'Cent East + LI
$a_7 * cost_K * load_m / load_K +$	'NYC + LI
$a_8 * cost_K * load_m / load_K$	'Cent East + LI + NYC

In all cases, the variables are:

a_1 = fraction of time when no constraints exist

a_2 = fraction of time when Central East interface alone is constraining

a_3 = fraction of time when Sprainbrook-Dunwoodie interface alone is constraining

a_4 = fraction of time when Con Ed-Long Island (including the Y49/Y50 lines) interfaces are constraining, but Central East and Sprainbrook-Dunwoodie interfaces are not constraining

a_5 = fraction of time when Central East and Sprainbrook-Dunwoodie interfaces are constraining but Con Ed-Long Island (including the Y49 and Y50 lines) interfaces are not constraining

a_6 = fraction of time when Central East, Con Ed-Long Island interfaces (including the Y49/Y50 lines) are constraining but the Sprainbrook-Dunwoodie interface is not constraining

a_7 = fraction of time when Sprainbrook-Dunwoodie, Con Ed-Long Island interfaces (including the Y49/Y50 lines) are constraining but the Central East interface is not constraining

a_8 = fraction of time when Central East, Sprainbrook-Dunwoodie, Con Ed-Long Island interfaces (including the Y49/Y50 lines) are constraining

$cost_{A\dots K}$ = revenue deficiencies due to DER Aggregation Demand Reductions in Load Zones A...K, calculated on a hourly basis

$load_m$ = real-time Load for Transmission Customer m, calculated on an hourly basis

$load_{A\dots K}$ = real-time Loads for all Transmission Customers in Load Zones A...K, calculated on an hourly basis

Appendix N. Station Power Settlements

Station Power is defined in the NYISO Market Administration and Control Area Services Tariff (Services Tariff) as the energy “for operating electric equipment located on the Generator site, or portions thereof, owned by the same entity that owns the Generator, which electrical equipment is used by the Generator exclusively for the production of Energy and any useful thermal energy associated with the production of Energy; and for the incidental heating, lighting, air conditioning and office equipment needs of buildings, or portions thereof, that are: a. owned by the same entity that owns the Generator; b. located on the Generator site; and c. used by the Generator exclusively in connection with the production of Energy and any useful thermal energy associated with the production of Energy. Station Power does not include any Energy: (i) used to power synchronous condensers; (ii) used for pumping at a pumped storage facility or for charging a Limited Energy Storage Resource and Energy Storage Resources when that Energy is stored for later injection back to the grid; or (iii) provided during a Black Start restoration by Generators that provide Black Start Capability Service; or (iv) used by a Resource in an DER Aggregation” (Services Tariff Section 2.19). Station Power may be procured in three ways:

- **Self-Supply:** The netting of generation output against station service load over a monthly period for the same unit or complex of units associated with the same Corporate Entity (CE).
- **Remote Self-Supply:** The netting of generation output against station service load over a monthly period for units owned by the same CE located remotely.
- **Third-Party Supply:** The net of station service load over generation output remaining after Self-Supply and Remote Self-Supply.

For Energy Storage Resources, the generator output MWh used in the Station Power calculation will be the net of generator injections and the generator withdrawals for the hour. For hours where generator withdrawals exceeds generator injections a zero value will be used as the generator’s hourly output.

All Station Power is settled at wholesale generation rates. However, each Generator that consumes Third-Party Station Power will receive a rebate from the NYISO for the wholesale cost of the third-party energy that is consumed. In addition, the NYISO will charge the appropriate LSE / TO the exact amount the Generators collected as a rebate. These rebate/charge values appear on line items in the Consolidated Invoice. The Station Power monthly report contains Station Power Accounting and metering details on a generator-by-generator basis. Table 0.9 summarizes all charges associated with Station Power.

Table 0.9 Summary of All Charges Associated with Station Power

Station Power Type	NYISO Energy Charges	T.O. Energy Charge to Generator	NYISO Rebates Cost of Wholesale Energy Consumed	NYISO Charges LSE - T.O. Cost of Wholesale Energy Consumed	NTAC Paid by	Ancillary Services Paid by:	TSC Paid by:
--------------------	----------------------	---------------------------------	---	--	--------------	-----------------------------	--------------

Self-Supply	Wholesale	None	No	No	None	None	n/a
Remote Self-Supply	Wholesale	None	No	No	Generator	None	Generator
Third-Party Supply	Wholesale	Retail	Yes	Yes	LSE	LSE	Generator

Generators participating in the Station Power program enter their hourly forecasts for Station Power consumption; these load forecasts are used for the initial monthly invoice. Metering Authorities (MAs) report non-zero load data (hourly load bus data greater than zero) for all hours, regardless of a unit's status as on or off-line. If MAs do not upload their readings, the missing reading will be treated as 0 MW. These Load Bus meter readings are used for the 4-month true-up and all other subsequent invoices.

Determination of Monthly Net Generation

The NYISO determines net generation for each unit for each hour based on (i) hourly outputs (ii) the initial load forecasts and (iii) the finalized Station Power load bus meter readings. If hourly net generation is a negative value, then the unit consumed more megawatts in Station Power than it produced as energy in that hour. As a hypothetical example, Table 0.10 illustrates net generation for four units for one month.

Table 0.10 Sample Net Generation for Four Units for One Month

Net Generation by Unit															
HB	0	1	2	3	4	...	713	714	715	716	717	718	719	Net	Neg Net
Gen 1	10.0	8.0	-1.0	-2.0	0.0	...	0.0	-2.0	-2.0	-1.0	5.0	10.0	10.0	35.0	-8.0
Gen 2	4.0	2.0	-4.0	-5.0	0.0	...	0.0	-5.0	-4.0	-5.0	-4.0	-5.0	-4.0	-30.0	-36.0
Gen 3	-4.0	-4.0	-4.0	-4.0	0.0	...	0.0	-4.0	-4.0	-4.0	-4.0	2.0	4.0	-26.0	-32.0
Gen 4	-3.0	-3.0	-3.0	-3.0	0.0	...	0.0	-3.0	-3.0	-3.0	-3.0	4.0	8.0	-12.0	-24.0
Owner Total:														-33.0	

Note: Neg Net (negative net generation by unit) represents the monthly sum of all hourly negative readings for a unit and does not include any hourly positive readings

In Table 0.10, four affiliated units combined to consume more megawatts than they generated over a month (-33 MW). In this case, all net megawatts consumed as Station Power will be considered self-supplied (or remotely self-supplied), with the exception of the 33MW that were third-party supplied.

The total net output is used to determine whether Third-Party Station Power supply took place. In this example, since the owner's total net output (-33 MW) is a negative number, some supply of Station Power by a Third-Party Station Power took place (and remote self-supply Station Power may exist). If the total net output had been a positive number in this example, there would be no Third-Party Station Power. However,

the units could remote self-supply Station Power to other generators under the same CE.

Allocation of Third-Party Station Power to Net Negative Units

If it is determined that Third-Party Station Power took place, this consumption is allocated to specific units. For CEs that have negative monthly net generation (i.e., an owner’s total negative net output, as in the example above), load is first allocated to the units with the greatest negative output until all of the CE’s negative monthly net generation is accounted for. Using the example above, the allocation of third party-supplied Station Power to net negative units would be determined as follows in Table 0.11:

Table 0.11 Sample Allocation of Third-Party Supplied Station Power to Net Negative Units

Generator	Unit Net Gen	Allocation
1	35.0	0.0
2	-30.0	30.0
3	-26.0	3.0
4	-12.0	0.0
Owner Total:	-33.0	33.0

The 33 MW of third party-supplied Station Power would be covered first by Unit 2 since it had the greatest negative output over the month, as illustrated in Table 0.12:

Table 0.12 Allocation of Third-Party Station Power

Generator	Unit Net Gen	Allocation
1	35.0	0.0
2	-30.0	30.0
3	-26.0	3.0
4	-12.0	0.0
Owner Total:	-33.0	33.0

In the example illustrated in Table 0.13, the absolute value of the owner’s total (33MW) is greater than the Station Power consumed by Unit 2 (30MW), so all of Unit 2’s monthly net generation is considered to be Third-Party Station Power. If the owner’s total were less than the most negative unit’s monthly net generation, the most negative unit would cover the owner’s total and no further allocations of load would be necessary. After Unit 2’s megawatts have been allocated, 3MW of Third-Party Station Power remain. Unit 3 (26MW) is the remaining unit with the highest negative monthly net generation and, therefore, is allocated the remaining 3MW of negative net generation. At this point, all of the CE’s negative monthly net generation has been accounted for and no more Third-Party Station Power will be allocated.

Table 0.13 Allocation of Remaining Third-Party Station Power

Generator	Unit Net Gen	Allocation
1	35.0	0.0
2	-30.0	30.0
3	-26.0	3.0
4	-12.0	0.0
Owner Total:	-33.0	33.0

For this example, allocating Third-Party Station Power to units with a negative net generation results in only Units 2 (30MW) and 3 (3MW) receiving Station Power as third-party supply. If the remaining megawatt load from the second allocation was greater than Unit 3’s negative monthly net generation, then the iterative process would continue until all third-party supplied Station Power was allocated.

Remote Self Supply Station Power

After allocating Third-Party Station Power, any remaining monthly net generation is considered remotely self-supplied Station Power. For instance, in the example above, the 23MW (26MW – 3MW) consumed by Unit 3 (i.e., the megawatts not allocated to third-party supply and the 12 MW of load consumed by Unit 4 are considered to be remote self-supply Station Power. These 35 MW (23MW + 12 MW) are remotely self-supplied from the 35 MW produced by Unit 1.

Table 0.14 Remote Self-Supply Station Power Load Allocation

Remote Self-Supply Allocation				
Generator	1	2	3	4
Monthly Net Gen	35.0	-30.0	-26.0	-12.0
Allocated Third-Party Megawatt Hours	0.0	30.0	3.0	0.0
Remote Self Supply Megawatt Hours	0.0	0.0	23.0	12.0

NTAC and TSC are charged, as typically applied to normal load, for each megawatt of consumed Remote Self-Supply Station Power.

Determining the Wholesale Cost of Third-Party Station Power

After determining the type of Station Power for which units are eligible, the hourly wholesale cost is determined for units that have been allocated Third-Party Station Power. In the examples above, only Units 2 and 3 were allocated third-party station supply and only these units are allocated the associated wholesale costs.

The wholesale cost of Third-Party Station Power is determined by multiplying the hourly unit net generation (Table 0.10) by the unit's allocation of third-party supply (Table 0.13) and dividing by the unit's negative net generation (Table 0.10). This calculation is only performed for hours that have a negative hourly unit net generation value.

For example, Unit 2 has a net generation of -5.00MW for hour 3 and an allocation of third-party supply of 30MW. Unit 2 has negative net generation totaling -36.00MWh over the month. Unit 2's Third-Party Station Power megawatt allocation for hour 3 is $((-5.00 \times 30.000) / 36.00) = 4.167\text{MW}$, as illustrated in Table 0.15.

Table 0.15 Hourly Third-Party Station Power Load Allocation

HB	0	1	2	3	4	...	713	714	715	716	717	718	719	Ttl	Neg Net
Gen 1	0.0	0.0	0.0	0.0	0.0	...	0.0	0.0	0.0	0.0	0.0	0.0	0.0	0.0	0.0
Gen 2	0.0	0.0	3.333	4.167	0.0	...	0.0	4.167	3.333	4.167	3.333	4.167	3.333	30.0	-36.0
Gen 3	0.375	0.375	0.375	0.375	0.0	...	0.0	0.375	0.375	0.375	0.375	0.0	0.0	3.0	-32.0
Gen 4	0.0	0.0	0.0	0.0	0.0	...	0.0	0.0	0.0	0.0	0.0	0.0	0.0	0.0	0.0
Owner Total:														33.0	

The hourly wholesale cost of Third-Party Station Power is determined by multiplying the hourly third-party megawatt allocation by the hourly Zonal LBMP, as illustrated in Table 0.16.

Table 0.16 Hourly Third-Party Station Power Costs

HB	0	1	2	3	...	714	715	716	717	718	719
Gen 1	\$33.62	\$28.46	\$21.72	\$22.54	...	\$42.86	\$42.58	\$51.36	\$45.63	\$40.47	\$30.12
Gen 2	\$33.62	\$28.46	\$21.72	\$22.54	...	\$42.86	\$42.58	\$51.36	\$45.63	\$40.47	\$30.12
Gen 3	\$33.62	\$28.46	\$21.72	\$22.54	...	\$42.86	\$42.58	\$51.36	\$45.63	\$40.47	\$30.12
Gen 4	\$33.62	\$28.46	\$21.72	\$22.54	...	\$42.86	\$42.58	\$51.36	\$45.63	\$40.47	\$30.12

For example, Unit 2 has an Hourly third-party Allocation for hour 3 of 4.167MW and a Zonal LBMP of \$22.54. The Hourly Retail Load Adjustment \$ is $4.167 \times \$22.54 = \93.92 (see Table 0.17).

Table 0.17 Hourly Third-Party Station Power Cost Allocation

HB	0	1	2	3	...	714	715	716	717	718	719	Total
Gen 1	\$0.00	\$0.00	\$0.00	\$0.00	...	\$0.00	\$0.00	\$0.00	\$0.00	\$0.00	\$0.00	\$0.00
Gen 2	\$0.00	\$0.00	\$72.41	\$93.92	...	\$178.58	\$141.93	\$214.00	\$152.10	\$168.63	\$100.40	\$1,121.97
Gen 3	\$12.61	\$10.67	\$8.15	\$8.45	...	\$16.07	\$15.97	\$19.26	\$17.11	\$0.0	\$0.00	\$108.29

Gen 4	\$0.00	\$0.00	\$0.00	\$0.00	...	\$0.00	\$0.00	\$0.00	\$0.00	\$0.00	\$0.00	\$0.00
Owner Total:												\$1,230.95

The monthly wholesale cost of Third-Party Station Power is determined by aggregating the hourly Third-Party Station Power wholesale cost values for each hour during the month where a unit had a negative hourly net generation. For this example, the monthly wholesale cost of third-party Station Power for Unit 2 is \$1,121.97. Participants in the Station Power program should note that in instances where Third-Party Station Power is supplied, the associated LSE / TO pays the NTAC and administers the settlement for the TSC.

Rebates and Charges for Third-Party Station Power

Each generator is paid a rebate by the NYISO for the monthly wholesale cost of the consumed Third-Party Station Power. The NYISO, in turn, charges the LSE / TO the exact amount that the Generator collected as rebates from NYISO. The LSE / TO can then charge the Generator for these third party-supplied megawatts.

As indicated in the example above, the monthly wholesale cost of Third-Party Station Power for Unit 2 is \$1,121.97, which is the rebate paid to Unit 2. The rebate for Unit 3 is calculated in a likewise fashion.

The NYISO charges the LSE / TO the amount rebated to the Generator. In the above example, the amount charged to the LSE / TO for Unit 2 is \$1,121.97. These charges and rebates are summarized in Table 0.18.

Table 0.18 Third-Party Station Power Charges and Rebates

Generator	NYISO Rebate to Generator	NYISO Charge to LSE	Energy Megawatt Hours LSE Can Charge to Generator
Gen 2	\$1,121.97	\$1,121.97	30.0
Gen 3	\$108.29	\$108.29	3.0